

# THE TANK AND MECHANIZED INFANTRY BATTALION TASK FORCE



**JUNE 2003**

HEADQUARTERS  
DEPARTMENT OF THE ARMY

**DISTRIBUTION RESTRICTION:** Approved for public release; distribution is unlimited.

# THE TANK AND MECHANIZED INFANTRY BATTALION TASK FORCE

## CONTENTS

	Page
<b>PREFACE</b> .....	xiii
 <b>CHAPTER 1 THE ROLE OF THE TANK AND MECHANIZED INFANTRY BATTALION TASK FORCE</b>	
Section I. Battalion and Task Force Mission Essential Tasks.....	1-1
1-1. Battalion Task Force Mission Essential Task Development ....	1-1
1-2. Operational Environment.....	1-2
1-3. Full-Spectrum Operations.....	1-5
Section II. Operational Framework .....	1-6
1-4. Area of Operations.....	1-6
1-5. Area of Interest .....	1-6
1-6. Battlespace .....	1-7
1-7. Battlefield Organization.....	1-7
1-8. Decisive Operations.....	1-8
1-9. Shaping Operations.....	1-8
1-10. Sustaining Operations .....	1-9
1-11. Main Effort .....	1-9
 <b>CHAPTER 2 ORGANIZATION AND CAPABILITIES</b>	
Section I. Organization, Capabilities, and Limitations .....	2-1
2-1. Organization.....	2-1
2-2. Capabilities .....	2-4
2-3. Limitations .....	2-4
2-4. Task Force Battlefield Focus .....	2-4
Section II. Duties and Responsibilities of Key Personnel.....	2-5
2-5. Task Force Commander.....	2-5
2-6. Personal Staff Group.....	2-5
2-7. Coordinating Staff and Organizations .....	2-6

DISTRIBUTION RESTRICTION: Approved for public release, distribution is unlimited.

\*This publication supersedes FM 71-2, dated 27 September 1988.

2-8.	The Headquarters and Headquarters Company Commander and the Forward Support Company Commander in Force XXI Organizations .....	2-15
2-9.	Company Team Commanders .....	2-15
2-10.	Scout Platoon Leader .....	2-16
2-11.	Mortar Platoon Leader .....	2-16
2-12.	Special Staff .....	2-16

**CHAPTER 3 BATTLE COMMAND**

Section	I.	The Art of Command .....	3-1
	3-1.	Role of the Commander .....	3-1
	3-2.	Mission Command .....	3-1
	3-3.	Location of the Commander .....	3-2
	3-4.	Combining the Art of Command and the Science of Control .....	3-3
Section	II.	Command and Control .....	3-5
	3-5.	The Command and Control System .....	3-5
	3-6.	Digitation and the C2 System .....	3-6
	3-7.	Exercising Command and Control .....	3-6
	3-8.	Distribution of Task Force Command and Control .....	3-7
Section	III.	Planning for Operations .....	3-9
	3-9.	Information Systems Enhancement to Decision-Making .....	3-9
	3-10.	The Military Decision-Making Process .....	3-11
	3-11.	Roles of the Commander and Executive Officer .....	3-12
	3-12.	The Role of Intelligence, Surveillance, and Reconnaissance .....	3-13
Section	IV.	The Military Decision-Making Process .....	3-13
	3-13.	Receipt of Mission .....	3-14
	3-14.	Mission Analysis .....	3-14
	3-15.	Course of Action Development .....	3-15
	3-16.	Course of Action Analysis (War Game) .....	3-15
	3-17.	Course of Action Comparison .....	3-15
	3-18.	Course of Action Approval .....	3-15
	3-19.	Orders Production .....	3-15
	3-20.	Decision-Making in a Time-Constrained Environment .....	3-15
Section	V.	Preparing for Operations .....	3-22
	3-21.	Intelligence, Surveillance, and Reconnaissance Operations .....	3-22
	3-22.	Security .....	3-23
	3-23.	Force Protection .....	3-23
	3-24.	Plan Revision and Refinement .....	3-23
	3-25.	Coordination and Liaison .....	3-23
	3-26.	Rehearsals .....	3-24
Section	VI.	Execution .....	3-24
	3-27.	The Command and Control System During Execution .....	3-24
	3-28.	Adapting to Changes .....	3-25
	3-29.	Assessment .....	3-25

		Page
	3-30. Decisions.....	3-26
	3-31. Directing Action .....	3-28
	3-32. Training and Performance .....	3-28
<b>CHAPTER 4 INTELLIGENCE, SURVEILLANCE, AND RECONNAISSANCE OPERATIONS</b>		
Section	I. Fundamentals of Information Collection Management .....	4-1
	4-1. Collection Management .....	4-2
	4-2. Tiers of Reconnaissance .....	4-7
	4-3. Reconnaissance Operations .....	4-8
	4-4. Reconnaissance Guidance.....	4-9
	4-5. Forms of Reconnaissance .....	4-11
	4-6. Intelligence, Surveillance, Reconnaissance Order Development.....	4-12
	4-7. Intelligence, Surveillance, Reconnaissance Overlay .....	4-14
	4-8. Enemy Situation Template.....	4-15
	4-9. Terrain Management.....	4-16
Section	II. Security Operations.....	4-17
	4-10. Screen.....	4-17
	4-11. Guard .....	4-18
	4-12. Area Security .....	4-22
	4-13. Cover.....	4-22
Section	III. Reconnaissance.....	4-22
	4-14. Task Force Reconnaissance and Surveillance .....	4-23
	4-15. Fundamentals.....	4-23
	4-16. Capabilities .....	4-25
	4-17. Integration of Brigade Reconnaissance Troop and Task Force Scout Platoons .....	4-26
	4-18. Supporting Assets Normally Available to Task Force .....	4-28
<b>CHAPTER 5 OFFENSIVE OPERATIONS</b>		
Section	I. Fundamentals of Offensive Operations .....	5-1
	5-1. Characteristics of Offensive Operations .....	5-1
	5-2. Contact Continuum.....	5-2
	5-3. Organization of Offensive Operations.....	5-3
Section	II. Forms of Maneuver.....	5-7
	5-4. Envelopment .....	5-7
	5-5. Penetration .....	5-9
	5-6. Turning Movement .....	5-10
	5-7. Infiltration .....	5-11
	5-8. Frontal Attack .....	5-13
	5-9. Sequence of Offensive Operations .....	5-14
	5-10. Movement Techniques and Formations.....	5-15
Section	III. Types of Offensive Operations .....	5-20
	5-11. Movement to Contact.....	5-20

		<b>Page</b>
	5-12.	Approach March Technique ..... 5-22
	5-13.	Integration of CS and CSS Elements ..... 5-24
	5-14.	Planning ..... 5-26
	5-15.	Execution ..... 5-31
	5-16.	Attacks ..... 5-34
	5-17.	Characteristics of the Attack ..... 5-35
	5-18.	Force-Oriented Attack against a Stationary Enemy Force ..... 5-35
	5-19.	Force-Oriented Attack against a Moving Enemy Force ..... 5-43
	5-20.	Terrain-Oriented Attacks ..... 5-50
	5-21.	Exploitation ..... 5-51
	5-22.	Pursuit ..... 5-52
	5-23.	Special Purpose Attacks ..... 5-52
Section	IV.	Transition Operations ..... 5-55
	5-24.	Consolidation ..... 5-55
	5-25.	Reorganization ..... 5-55
	5-26.	Continuing Operations ..... 5-56
	5-27.	Defend ..... 5-56
 <b>CHAPTER 6 DEFENSIVE OPERATIONS</b>		
Section	I.	Fundamentals of the Defense ..... 6-1
	6-1.	Purpose of the Defense ..... 6-1
	6-2.	Organization of Defensive Actions ..... 6-1
	6-3.	Characteristics of the Defense ..... 6-3
Section	II.	Types of Defensive Operations ..... 6-5
	6-4.	Area Defense ..... 6-5
	6-5.	Mobile Defense ..... 6-19
	6-6.	Retrograde Operations ..... 6-19
	6-7.	Delay ..... 6-20
	6-8.	Delay Organization ..... 6-21
	6-9.	Delay Planning Considerations ..... 6-21
	6-10.	Delay Scheme of Maneuver ..... 6-22
	6-11.	Maximizing the Use of Terrain in a Delay ..... 6-23
	6-12.	Forcing the Enemy to Deploy and Maneuver in a Delay ..... 6-23
	6-13.	Avoiding Decisive Engagement in a Delay ..... 6-23
	6-14.	Parameters of the Delay Order ..... 6-24
	6-15.	Alternate and Subsequent Positions in a Delay ..... 6-25
	6-16.	Fire Support in a Delay ..... 6-27
	6-17.	Engineer Support in a Delay ..... 6-28
	6-18.	Air Defense Support in a Delay ..... 6-28
	6-19.	Nuclear, Biological, and Chemical Support in a Delay ..... 6-28
	6-20.	Combat Service Support in a Delay ..... 6-28
	6-21.	Delay Preparations ..... 6-29
	6-22.	Execution of a Delay ..... 6-30
	6-23.	Withdrawal ..... 6-32
	6-24.	Withdrawal Organization ..... 6-32

		Page
	6-25.	Withdrawal Planning Considerations ..... 6-34
	6-26.	Withdrawal Scheme of Maneuver ..... 6-34
	6-27.	Withdrawal Preparation ..... 6-35
	6-28.	Withdrawal Execution ..... 6-35
	6-29.	Concealing the Withdrawal ..... 6-36
	6-30.	Disengagement in a Withdrawal..... 6-36
	6-31.	Actions on Contact in a Withdrawal..... 6-36
	6-32.	Terminating the Withdrawal..... 6-36
	6-33.	Retirement..... 6-37
Section	III.	Defensive Planning Considerations ..... 6-37
	6-34.	Defensive Planning..... 6-37
	6-35.	Intelligence Preparation of the Battlefield..... 6-38
	6-36.	Reserve..... 6-40
Section	IV.	Sequence of the Defense..... 6-41
	6-37.	Occupation and Establishment of Security ..... 6-42
	6-38.	Preparation and Continued Security Operations..... 6-42
	6-39.	Security Area Engagement ..... 6-42
	6-40.	Main Battle Area Engagement..... 6-43
	6-41.	Follow-On Missions ..... 6-44
Section	V.	Defensive Techniques..... 6-44
	6-42.	Defense of an Area of Operations..... 6-44
	6-43.	Defense from a Battle Position ..... 6-47
	6-44.	Reverse Slope Defense ..... 6-49
	6-45.	Defense of a Strongpoint ..... 6-51
	6-46.	Perimeter Defense..... 6-56
	6-47.	Counterattack..... 6-58
Section	VI.	Counter mobility, Mobility, and Survivability Integration..... 6-61
	6-48.	Counter mobility ..... 6-61
	6-49.	Survivability..... 6-66
 <b>CHAPTER 7 URBAN OPERATIONS</b>		
Section	I.	Introduction..... 7-1
	7-1.	General Considerations of Urban Operations..... 7-1
	7-2.	Armor and Mechanized Forces Role in Urban Operations..... 7-2
	7-3.	Tactical Challenges..... 7-2
Section	II.	Mission, Enemy, Terrain and Weather, Troops and Support Available, Time Available, and Civil Considerations (METT-TC) ..... 7-3
	7-4.	Mission ..... 7-4
	7-5.	Enemy ..... 7-4
	7-6.	Urban Mapping..... 7-7
	7-7.	Terrain and Weather ..... 7-11
	7-8.	Troops ..... 7-14
	7-9.	Time..... 7-15
	7-10.	Civil Considerations ..... 7-15

		<b>Page</b>
Section	III. Controlling Operations.....	7-16
	7-11. Enemy Focus.....	7-16
	7-12. Commander's Critical Information Requirements .....	7-17
	7-13. Task-Organization of Units to Accomplish Specific Tasks .....	7-17
	7-14. Rehearsals .....	7-18
	7-15. Fire Support .....	7-19
	7-16. Field Artillery .....	7-19
	7-17. Mortars.....	7-21
	7-18. Communications .....	7-21
	7-19. Weapons Effects .....	7-21
Section	IV. Offensive Operations .....	7-22
	7-20. Offensive Framework .....	7-23
	7-21. Types of Attack during Urban Offensive Operations .....	7-23
	7-22. Transition.....	7-27
	7-23. Movement to Contact.....	7-28
	7-24. Attack of a Village.....	7-29
	7-25. Nodal Attack.....	7-29
Section	V. Defensive Operations.....	7-31
	7-26. Defensive Framework.....	7-31
	7-27. Defensive Planning.....	7-32
	7-28. Integrating the Urban Area into the Defense .....	7-33
	7-29. Nodal Defense.....	7-34
	7-30. Delay.....	7-36
 <b>CHAPTER 8 STABILITY OPERATIONS AND SUPPORT OPERATIONS</b>		
Section	I. Stability Operations .....	8-1
	8-1. Purpose.....	8-1
	8-2. Types of Stability Operations .....	8-3
	8-3. Peace Operations.....	8-3
	8-4. Foreign Internal Defense .....	8-5
	8-5. Security Assistance.....	8-6
	8-6. Humanitarian and Civic Assistance.....	8-6
	8-7. Support to Insurgency.....	8-6
	8-8. Support to Counterinsurgency .....	8-6
	8-9. Support to Counterdrug Operations.....	8-6
	8-10. Combating Terrorism.....	8-6
	8-11. Noncombatant Evacuation Operations .....	8-7
	8-12. Arms Control .....	8-8
	8-13. Show of Force.....	8-8
	8-14. Planning Considerations .....	8-9
	8-15. Decentralized Operations.....	8-9
	8-16. Rules of Engagement.....	8-9
	8-17. Rules of Interaction.....	8-10
	8-18. Force Protection.....	8-11

		Page
	8-19. Task Organization.....	8-12
	8-20. Media Considerations .....	8-12
	8-21. Operations with Outside Agencies .....	8-13
	8-22. Specific Considerations by BOS.....	8-13
	8-23. Intelligence.....	8-14
	8-24. Maneuver .....	8-16
	8-25. Aviation Support.....	8-16
	8-26. Fire Support .....	8-17
	8-27. Mobility and Survivability.....	8-17
	8-28. Air Defense .....	8-18
	8-29. Combat Service Support .....	8-18
	8-30. Command and Control Information Systems .....	8-19
	8-31. Techniques .....	8-20
	8-32. Presence Patrols .....	8-20
	8-33. Observation Posts .....	8-20
	8-34. Providing Security for Indigenous Authorities.....	8-21
	8-35. Static Security Posts.....	8-22
	8-36. Searches .....	8-23
	8-37. Roadblocks and Other Checkpoints.....	8-28
	8-38. React to Civil Disturbance .....	8-30
Section	II. Support Operations .....	8-30
	8-39. Types of Support Operations .....	8-30
	8-40. The Army's Role in Support Operations .....	8-31
	8-41. Forms of Support Operations.....	8-32
	8-42. Planning Considerations .....	8-34
	8-43. Considerations for Support Operations.....	8-35
	8-44. Planning Process.....	8-35
	8-45. Command and Control.....	8-36
	8-46. Maneuver .....	8-37
	8-47. Intelligence.....	8-37
	8-48. Intelligence, Surveillance, and Reconnaissance .....	8-37
	8-49. Fire Support .....	8-37
	8-50. Mobility and Survivability.....	8-38
	8-51. Air Defense.....	8-38
	8-52. Combat Service Support .....	8-38
	8-53. Information Operations.....	8-39
	8-54. Other Planning Considerations .....	8-39
	8-55. Pattern of Operations .....	8-40
	8-56. Sequence of Operations .....	8-42
	8-57. Transition to Combat .....	8-44
	8-58. Training Considerations.....	8-44
	8-59. Training for Support Operations.....	8-44
	8-60. Domestic Support Operations- or Foreign Humanitarian Assistance-Specific Training .....	8-45
	8-61. Additional Requirements .....	8-46



**CHAPTER 9 COMBAT SUPPORT OPERATIONS**

Section	I. Fire Support.....	9-1
	9-1. Fires.....	9-1
	9-2. Fire Support Organizations .....	9-2
	9-3. Fire Support Planning and Coordination.....	9-3
	9-4. Essential Fire Support Tasks .....	9-6
	9-5. Scheme of Fires.....	9-8
	9-6. Quick Fire Planning.....	9-8
	9-7. Observation Planning.....	9-10
	9-8. Top-Down Fire Planning.....	9-12
	9-9. Battle Damage Assessment .....	9-13
	9-10. Fire Support Coordination.....	9-14
	9-11. Rehearsals.....	9-15
	9-12. Clearance of Fires.....	9-17
	9-13. AFATDS and Clearance of Fires .....	9-18
	9-14. FBCB2 and Clearance of Fires.....	9-19
	9-15. Radar Zones.....	9-19
	9-16. Fire Support Assets .....	9-21
	9-17. Mortars .....	9-24
	9-18. Mortars in the Task Force Close Fight.....	9-27
	9-19. Close Air Support.....	9-28
	9-20. Army Aviation.....	9-28
	9-21. FBCB2-Generated Fire Missions .....	9-28
Section	II. Close Air Support.....	9-30
	9-22. Missions.....	9-30
	9-23. Planning Considerations.....	9-32
	9-24. Air Force Support.....	9-32
	9-25. Close Air Support Planning Duties and Responsibilities.....	9-33
	9-26. Suppression of Enemy Air Defense .....	9-35
	9-27. Weather .....	9-36
Section	III. Engineers.....	9-36
	9-28. Battalion Planning for Maneuver Support.....	9-36
	9-29. Mobility.....	9-38
	9-30. Countermobility.....	9-39
	9-31. Survivability .....	9-39
	9-32. General Engineering.....	9-39
	9-33. Geospatial Engineering .....	9-39
	9-34. Engineer Battalion.....	9-39
	9-35. Engineer Company.....	9-40
	9-36. Combat Engineer (Sapper) Platoon.....	9-41
	9-37. Assault and Obstacle Platoon.....	9-41
	9-38. Engineer Assets .....	9-42
	9-39. SCATMINE Capabilities .....	9-43
	9-40. SCATMINE Limitations.....	9-44
	9-41. Command and Control of SCATMINES .....	9-45

		Page
Section	IV. Air Defense Support .....	9-46
	9-42. Mission .....	9-47
	9-43. Organizations.....	9-47
	9-44. Air Defense Planning Considerations .....	9-48
	9-45. Air Defense Officer Duties.....	9-50
	9-46. Offensive Considerations .....	9-51
	9-47. Defensive Considerations.....	9-51
	9-48. Air Defense Types.....	9-51
	9-49. Air Defense Warnings and Weapons Control Status .....	9-51
	9-50. Air Defense Assets .....	9-52
 <b>CHAPTER 10 COMBAT SERVICE SUPPORT</b>		
Section	I. Combat Service Support Functions and Organization .....	10-1
	10-1. Overview .....	10-1
	10-2. Combat Service Support Responsibilities .....	10-3
	10-3. The Headquarters and Headquarters Company (AOE).....	10-7
	10-4. The Force XXI Forward Support Company.....	10-9
	10-5. Forward Support Company Organization .....	10-12
Section	II. Combat Service Support Operations .....	10-13
	10-6. Arm (Class V) .....	10-13
	10-7. Fuel (Class III, Bulk).....	10-14
	10-8. Fix.....	10-15
	10-9. Move.....	10-17
	10-10. Sustain .....	10-18
	10-11. Man.....	10-24
Section	III. Combat Service Support Planning .....	10-26
	10-12. Planning Overview .....	10-27
	10-13. Logistics Estimate .....	10-28
	10-14. Supporting Offensive Operations.....	10-29
	10-15. Supporting Defensive Operations .....	10-32
	10-16. Echelon of the Trains .....	10-34
	10-17. Movement of the Trains .....	10-36
	10-18. LOGPAC Operations .....	10-37
	10-19. Trains and FSC Security.....	10-40
	10-20. Command and Control .....	10-40
	10-21. Communications.....	10-41
Section	IV. Reconstitution.....	10-41
	10-22. Reorganization.....	10-41
	10-23. Regeneration.....	10-42
 <b>CHAPTER 11 COMMAND POST OPERATIONS</b>		
Section	I. Command and Control Facilities .....	11-1
	11-1. Command Group.....	11-1
	11-2. Main Command Post .....	11-2
	11-3. Combat Trains Command Post.....	11-2

		Page
	11-4. Task Force Support Area Command Post (Force XXI)/Field Trains Command Post (AOE).....	11-3
	11-5. Command Post Survivability.....	11-4
	11-6. Displacement.....	11-5
Section	II. Command Post Operations.....	11-5
	11-7. Standing Operating Procedures.....	11-5
	11-8. Communications.....	11-6
	11-9. Maps.....	11-6
	11-10. The Battle Captain.....	11-6
Section	III. Communication.....	11-7
	11-11. Responsibilities.....	11-8
	11-12. Means of Communications.....	11-8
	11-13. Communications Security.....	11-10
Section	IV. Communications Systems.....	11-11
	11-14. Combat Net Radio.....	11-11
	11-15. Army Command User System.....	11-12
	11-16. Army Data Distribution System.....	11-12
	11-17. The Digital Battlefield.....	11-12
	11-18. Tactical Internet.....	11-12
	11-19. Force XXI Battle Command Brigade and Below.....	11-13
	11-20. Enhanced Position Location Reporting System with Very High Speed Integrated Circuits.....	11-14
	11-21. Responsibilities.....	11-14
Section	V. Digital Command and Control Systems and Architecture.....	11-15
	11-22. Army Battle Command System Components.....	11-15
	11-23. Digital Command and Control Techniques.....	11-17
	11-24. Standing Operating Procedure Considerations.....	11-22
	11-25. Integrating Digital and Analog Units.....	11-24
 <b>CHAPTER 12 TACTICAL ENABLING OPERATIONS</b>		
Section	I. Relief Operations.....	12-1
	12-1. Planning Considerations.....	12-1
	12-2. Conducting the Relief.....	12-2
	12-3. Command and Control.....	12-3
Section	II. Security Operations.....	12-3
	12-4. Screen.....	12-3
	12-5. Guard.....	12-5
	12-6. Area Security.....	12-8
	12-7. Cover.....	12-8
Section	III. Battle Handover and Passage of Lines.....	12-9
	12-8. Battle Handover.....	12-9
	12-9. Passage of Lines.....	12-10
	12-10. Forward Passage of Lines.....	12-14
	12-11. Rearward Passage of Lines.....	12-15
	12-12. Rehearsal.....	12-15

	<b>Page</b>
Section IV. Linkup Operations .....	12-16
12-13. Control during Linkup Operations.....	12-16
12-14. Forms of Linkup .....	12-16
Section V. River Crossing Operations.....	12-21
12-15. General Considerations.....	12-21
12-16. Assault of the Crossing Site.....	12-22
Section VI. Combined Arms Breaching Operations.....	12-24
12-17. Breach Tenets .....	12-24
12-18. Combined Arms Breach during Deliberate Operations.....	12-28
12-19. Combined Arms Breach during Hasty Operations .....	12-31
Section VII. Tactical Road March.....	12-34
12-20. March Elements .....	12-35
12-21. March Column Organization .....	12-35
12-22. Techniques .....	12-36
12-23. Planning Considerations .....	12-37
12-24. Movement Order.....	12-37
12-25. Control Measures.....	12-37
12-26. Security .....	12-39
Section VIII. Assembly Area Operations .....	12-40
12-27. Assembly Areas .....	12-40
12-28. Organization.....	12-41
12-29. Quartering Party.....	12-41
12-30. Occupation.....	12-44
12-31. Actions in the Assembly Area .....	12-45
12-32. Security .....	12-46
12-33. Departure from the Assembly Area.....	12-47
<b>APPENDIX A INTEGRATION OF HEAVY AND LIGHT FORCES.....</b>	<b>A-1</b>
<b>APPENDIX B AVIATION SUPPORT TO GROUND OPERATIONS .....</b>	<b>B-1</b>
<b>APPENDIX C OPERATIONS IN NUCLEAR, BIOLOGICAL,</b>	
<b>    AND CHEMICAL CONDITIONS.....</b>	<b>C-1</b>
<b>APPENDIX D RISK MANAGEMENT AND FRATRICIDE AVOIDANCE .....</b>	<b>D-1</b>
<b>APPENDIX E ENVIRONMENTAL CONSIDERATIONS.....</b>	<b>E-1</b>
<b>APPENDIX F SNIPER EMPLOYMENT .....</b>	<b>F-1</b>
<b>APPENDIX G FIRES INTEGRATION.....</b>	<b>G-1</b>
<b>APPENDIX H. DEPLOYMENT.....</b>	<b>H-1</b>
<b>APPENDIX I. PLANNING AND OPERATIONS CHARTS .....</b>	<b>I-1</b>
<b>APPENDIX J AIR ASSAULT OPERATIONS .....</b>	<b>J-1</b>
<b>GLOSSARY .....</b>	<b>Glossary-1</b>
<b>REFERENCES .....</b>	<b>References-1</b>
<b>INDEX .....</b>	<b>Index-1</b>

# PREFACE

FM 3-90.2 describes the tactical employment of the tank and mechanized infantry battalion task force. It specifically addresses operations for battalion task forces organized under the Army of Excellence (AOE) and the Limited Conversion Design (LCD)/Force XXI. FM 3-90.2 provides the doctrinal foundation that governs the development of equipment, training, and structure for tank and mechanized infantry battalion task forces. It provides basic doctrine, tactics, techniques of employment, organization, exercise of command and control (C2), movements and tactical operations appropriate to the battalion task force. The tactics, techniques, and procedures described herein are intended as a guide and are to be viewed as flexible in application, depending on the factors of METT-TC. Each situation in combat must be resolved by an intelligent interpretation and application of the doctrine set forth herein.

Because not all tank and mechanized infantry battalion task forces are digitally equipped, this manual addresses analog and digital operations, technology applications, and equipment. Tactical fundamentals do not change with the fielding of new equipment; however, the integration of new equipment and organizations may require changes in related techniques and procedures.

FM 3-90.2 is written for the commander, the staff, subordinate commanders, and all supporting units. It reflects and supports the Army operations doctrine as stated in FM 3-0 and FM 3-90 yet provides unique techniques specific to the audience of this manual, which are not covered in the above manuals. Examples and graphics are provided to illustrate principles and concepts--not to serve as prescriptive responses to tactical situations. FM 3-90.2 provides units with the doctrinal foundation to train leaders and staffs, guide tactical planning, and develop standing operating procedures (SOP). It applies to all tank and mechanized infantry task forces in the Active Component (AC) and Reserve Component (RC/national guard [NG]) forces.

This field manual is available on the General Dennis J. Reimer Training and Doctrine Digital Library at [www.adtdl.army.mil/atdls.htm](http://www.adtdl.army.mil/atdls.htm).

The proponents for this publication are The US Army Infantry School and US Army Armor School. Submit comments and recommended changes and the rationale for those changes to either of the following:

- [doctrine@benning.army.mil](mailto:doctrine@benning.army.mil) or on DA Form 2028 directly to Commandant, US Army Infantry School, ATTN: ATSH-ATD, Fort Benning, Georgia 31905-5410.
- <http://www.knox.army.mil> or on DA Form 2028 directly to Commander, US Army Armor Center, ATTN: ATZK-TDD-CA, Fort Knox, KY 40121-5000.

Unless this publication states otherwise, masculine nouns and pronouns do not refer exclusively to men.

---

CHAPTER 1

## THE ROLE OF THE TANK AND MECHANIZED INFANTRY BATTALION TASK FORCE

*The role of the tank and mechanized infantry battalion task force is to fight and win engagements on any part of the battlefield. The task force combines the efforts of its company teams, combat support, and combat service support elements to execute tactical missions as part of a brigade or division operation. Mechanized infantry and armor battalions are an essential part of the Army's principal formation for conducting sustained combined arms and close combat land operations. America's tank and mechanized infantry battalions serve as a deterrent to armed conflict and are capable of deploying worldwide and conducting full-spectrum operations.*

### Section I. BATTALION AND TASK FORCE MISSION ESSENTIAL TASKS

This manual addresses the tactical employment and operation of the battalion task force (TF), but battalion commanders must read and understand FM 3-90.3, FM 3-0, and FM 3-90. FM 3-0 establishes the Army's keystone doctrine for full-spectrum operations with warfighting as the Army's primary focus. Although built upon global strategic responsiveness for prompt, sustained Army force operations on land, FM 3-0 provides overarching doctrinal direction for the conduct of full-spectrum operations detailed in this and other Army manuals. FM 3-90 introduces the basic concepts and control measures associated with the art of tactics, but it cannot be read in isolation. FM 3-90 must be used with FM 3-0, the concepts in FM 3-07, and the "plan, prepare, execute, and assess" cycle as it relates to the military decision-making process (MDMP) that is described in FM 101-5. Together, these publications provide the essential framework for understanding this manual.

#### 1-1. BATTALION TASK FORCE MISSION ESSENTIAL TASK DEVELOPMENT

Tank and mechanized infantry task forces develop their mission essential tasks list (METL) based on their war plans and external directives as described in FM 7-0. Mission essential tasks are the operational expression of the tank and mechanized infantry task forces' core competencies. They describe what well-trained, superbly-led, and well-equipped soldiers do to support the Army's mission essential tasks of shaping the security environment, responding promptly to crisis, dominating land operations, and providing support to civil authorities (as described in FM 3-0).

a. **Shape the Security Environment.** National security and national military strategies establish an imperative for engagement. The US will remain politically and militarily engaged in the world and will maintain military superiority over potential adversaries. Forward basing, forward presence, and force projection enhance the ability of army forces to engage other nations--their people, governments, and militaries. Tank and mechanized infantry task forces provide an overwhelming presence to potential adversaries and allow these units to conduct full spectrum operations regardless of the

conditions. Due to their structure, and their ability to tailor a mounted force to the operational requirements, they are uniquely suited to counter forces hostile to the US and its allies. Battalion TFs undertake peacetime military engagement (PME) missions to reassure foreign governments, build trust and confidence, promote regional stability, reduce potential conflicts and threats, and deter aggression and coercion.

b. **Respond Promptly to Crisis.** The Army's capability to rapidly project its forces to any environment provides military leaders the ability to increase force presence, to increase the magnitude of the enemy's dilemma, and to act decisively within the time specified by the joint force commander (JFC). Battalion TFs train to rapidly deploy personnel and equipment utilizing rail, sealift, and airlift from home stations to a theater of operations or rapidly deploy personnel by airlift and draw equipment from prepositioned stocks enabling them to quickly maneuver throughout the depth of the area of operations (AO).

c. **Dominate Land Operations.** The threat or use of Army tank and mechanized forces to close with and destroy enemy forces through maneuver and precision direct and indirect fires is the ultimate means of imposing our will on the enemy and achieving a decisive outcome. These units provide the commander with the ability to seize enemy territory, destroy the enemy's armed forces, and eliminate his means of civil population control. Tank and mechanized infantry task forces conduct sustained and large-scale actions in full-spectrum operations throughout the depth of the AO. Sustained land operations provide for long-term establishment of conditions required by the nation in support of our national objectives. Faced with an enemy with the ability to conduct sustained resistance, the unit continuously creates conditions throughout the AO that lead to the enemy's ultimate defeat. Combat support (CS) and combat service support (CSS) by attached and supporting organizations make sustained land operations by the battalion TF possible.

## **1-2. OPERATIONAL ENVIRONMENT**

Tank and mechanized infantry task forces conduct operations in an operational environment consisting of six dimensions. Each affects how the unit combines, sequences, and conducts military operations. Commanders tailor forces, employ diverse capabilities, and support different missions to succeed in this environment.

a. **Threat Dimension.** Multiple threats to US national interests exist. Some threats are direct, such as a cross border attack; others are indirect, such as coercion. Some regional powers aspire to dominate their neighbors and have the required conventional force capabilities. Such situations may threaten US vital interests, US allies, or regional stability. Transnational groups conduct a range of activities that threaten US interests and citizens at home and abroad. Extremism, ethnic disputes, religious rivalries, and human disasters contribute to destabilizing governments and regions through extensive refugee migrations. Collectively, these transnational threats may adversely affect US interests and may result in military involvement (as further described in FM 3-0).

(1) In the foreseeable future, most nations will modernize and maintain a military capability for countering regional threats or seeking opportunities to further their national goals. Military change incorporates advances in information technology, ballistic and missile capabilities, weapons of mass destruction (WMD), and genetic engineering. Potential threats vary from heavy conventional units to adaptive, asymmetric forces

structured for local and regional use. Adversaries will seek and obtain technologies that challenge US strengths in information technology, navigation, night-vision systems, and precision targeting and strike capabilities. The proliferation of WMD and long-range delivery systems will enable adversaries to threaten US forces at greater ranges with increased lethality and precision.

(2) Adversaries will develop their warfighting doctrine based on perceived US strengths and vulnerabilities. They will try to prevent projection of US forces and control the nature and tempo of US actions through asymmetric operations and adaptive forces. They will attempt to counter US air operations and neutralize US technological advantages such as precision strike capabilities. Adversaries will use conventional and unconventional means to destroy our national will and our capability to wage war.

(3) Adversaries will also seek to shape the conditions to their advantage by changing the nature of the conflict or employing capabilities that they believe will be difficult for US forces to counter. They will use complex terrain, urban environments, and force dispersal-survival methods to offset US advantages.

(4) Our adversaries will continue to seek every opportunity (both foreign and domestic) to gain an advantage over US and multinational forces. When countered, they will adapt to the changing conditions and pursue all available options to avoid destruction or defeat. This environment and wide array of threats presents significant challenges. To counter such threats, tank and mechanized infantry task forces will be called upon to defeat a technologically sophisticated and lethal adversary while simultaneously protecting noncombatants and the infrastructure on which they depend.

b. **Political dimension.** Successful military operations require commanders to have a clear sense of objectives. They must understand how the use of military force fits into the national security strategy and the desired military conditions required to meet policy objectives. Each political decision during the conduct of operations has strategic, operational, and tactical implications. Likewise, each strategic, operational, and tactical action directly or indirectly impacts the political dimension.

c. **Unified Action Dimension.** The US national military strategy calls for Army forces to act as part of a fully interoperable and integrated joint force. Combat commanders synchronize air, land, sea, space, and special operations forces to accomplish their mission. Tank and mechanized infantry task forces can expect to operate in a unified command structure both in a major theater of war (MTW) and more commonly in small-scale contingencies (SSC). The tank and mechanized infantry task force may work with multinational and interagency partners to accomplish the full spectrum of missions. Tank and mechanized infantry task forces committed to SSCs can expect to protect American lives and interests, support political initiatives, facilitate diplomacy, promote fundamental ideals, and disrupt illegal activities. Close coordination is the foundation of successful unified action.

d. **Land Combat Operations Dimension.** Land combat continues to be the salient feature of combat and is the primary function of the battalion task force. Land combat usually involves destroying or defeating enemy forces or taking land objectives that reduce the enemy's willingness to fight. Four characteristics distinguish land combat: scope, duration, terrain, and permanence.

(1) **Scope.** Land combat involves direct and indirect combat with an enemy throughout the depth of an operational area. Forces conduct simultaneous and sequential



operations in contiguous and noncontiguous AOs. Commanders maneuver forces to seize and retain key and decisive terrain. They use the elements of combat power to defeat or destroy enemy forces.

(2) **Duration.** Land combat is repetitive and continuous. It involves rendering an enemy incapable or unwilling to conduct further action. It may require destroying him.

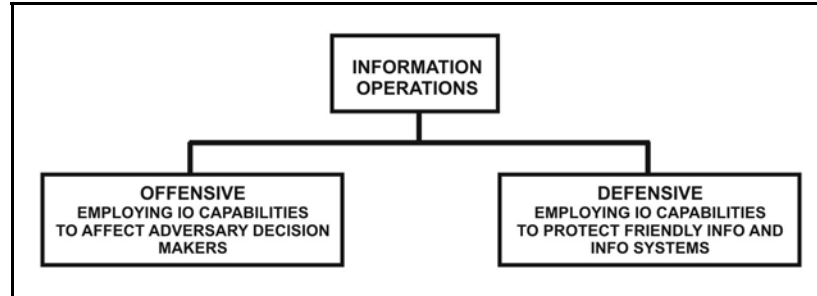
(3) **Terrain.** Land combat takes place amid a variety of natural and manmade features. The complexity of the ground environment contrasts significantly with the relative transparency of air, sea, and space. Plans for land combat must account for the visibility and clutter provided by the terrain and the effects of weather and climate.

(4) **Permanence.** Land combat frequently requires seizing or securing terrain. With control of terrain comes control of populations and productive capacity. Thus, land combat makes permanent the temporary effects of other operations.

e. **Information Dimension.** Decisive operations historically have been enabled by information superiority. Information superiority provides commanders with accurate, timely information that enables them to make superior decisions and act faster than their adversaries. Information superiority, derived from intelligence, surveillance, and reconnaissance (ISR); information management (IM); psychological operations (PSYOP); and information operations (IOs), provides a common framework for how to plan, task, and control assets; how and where to report information; and how to use information. The information environment also includes information derived from nongovernmental individuals and organizations, such as the media, that produce and disseminate information that affects public opinion that can alter the conduct and perceived legitimacy of military operations.

(1) IOs are the actions taken to enable, enhance, and protect the friendly force's ability to collect, process, and act on information to achieve an advantage over enemy forces. A successful IO program will effect our adversaries' decision-making processes, information, and information systems while defending our friendly decision-making processes, information, and information systems.

(2) Units conduct IOs across the full range of military operations from operations in garrison, through deployment to combat operations, and continuing through redeployment upon mission completion. Information operations include both offensive information operations and defensive information operations (Figure 1-1). IOs provide commanders with essential tools for protecting their organizations and systems. The overall force objectives are linked with higher headquarters objectives. IO objectives support these overall objectives and may be designated as high as the National Command Authority (NCA) and supported by several echelons of command. Available resources define what the forces can accomplish. The TF may have PSYOP personnel supporting it in order to assist the commander. The target audience may include enemy forces, the local population, and or displaced personnel moving through, or residing in, the area. PSYOP messages oriented to the local situation can be developed and produced using previously approved themes and objectives.



**Figure 1-1. Information operations.**

f. **Technological Dimension.** Technology enhances leader, unit, and soldier performance and impacts how Army forces plan, prepare, and execute full-spectrum operations in peace, conflict, and war. Technology has significantly increased our ability to conduct ISR operations, and it greatly enhances the ability to conduct battle command through modern telecommunications and microprocessing. Munitions are increasingly lethal and target acquisition systems are more precise. The proliferation of advanced technology systems requires the commander to integrate the capabilities of highly modernized organizations and less-modernized and multinational units. Additionally, commanders must also realize that they do not have a monopoly on advanced technology. Even adversaries lacking any research and development program can purchase sophisticated systems in the global marketplace and gain selected parity or superiority to US systems.

### 1-3. FULL-SPECTRUM OPERATIONS

Tank and mechanized infantry task forces are trained and equipped to conduct full-spectrum operations. Tank and mechanized infantry task force commanders may combine different types of operations simultaneously and sequentially to accomplish missions in war as well as military operations other than war (MOOTW). The Army's mounted forces are optimized for operations in an MTW but retain the ability to conduct SSC and PME missions.

a. Full-spectrum operations include offensive, defensive, stability, and support. Missions in any environment require brigades to conduct or be prepared to conduct any combination of these primary operations:

(1) **Offensive.** Offensive operations aim at destroying or defeating an enemy. Their purpose is to impose US will on the enemy for decisive victory.

(2) **Defensive.** Defensive operations defeat an enemy attack, buy time, economize forces, or develop conditions favorable for offensive operations. Defensive operations alone normally cannot achieve a decision. Their purpose is to create conditions for a counteroffensive that regains the initiative.

(3) **Stability.** Stability operations promote and protect US national interests by influencing diplomatic, civil, and military environments. Regional security is supported by a balanced approach that enhances regional stability and economic prosperity simultaneously. Army force presence promotes a stable environment.

(4) **Support.** Support operations employ Army forces to assist civil authorities, foreign or domestic, as they prepare for or respond to crises and relieve suffering. Domestically, Army forces respond only when directed by the NCA. Army forces operate

under the lead federal agency and comply with provisions of US law to include the Posse Comitatus Act and the Stafford Act.

b. Tank and mechanized infantry task forces normally conduct one type of operation at a time and transition from one type of operation to another as the strategic and operational requirements change.

## **Section II. OPERATIONAL FRAMEWORK**

The operational framework consists of the arrangements of friendly forces and resources in time, space, and purpose with respect to each other and the enemy or situation. Commanders design an operational framework to accomplish their mission by defining and arranging three components--the AO, battlespace, and battlefield organization. Commanders use the operational framework to focus combat power.

### **1-4. AREA OF OPERATIONS**

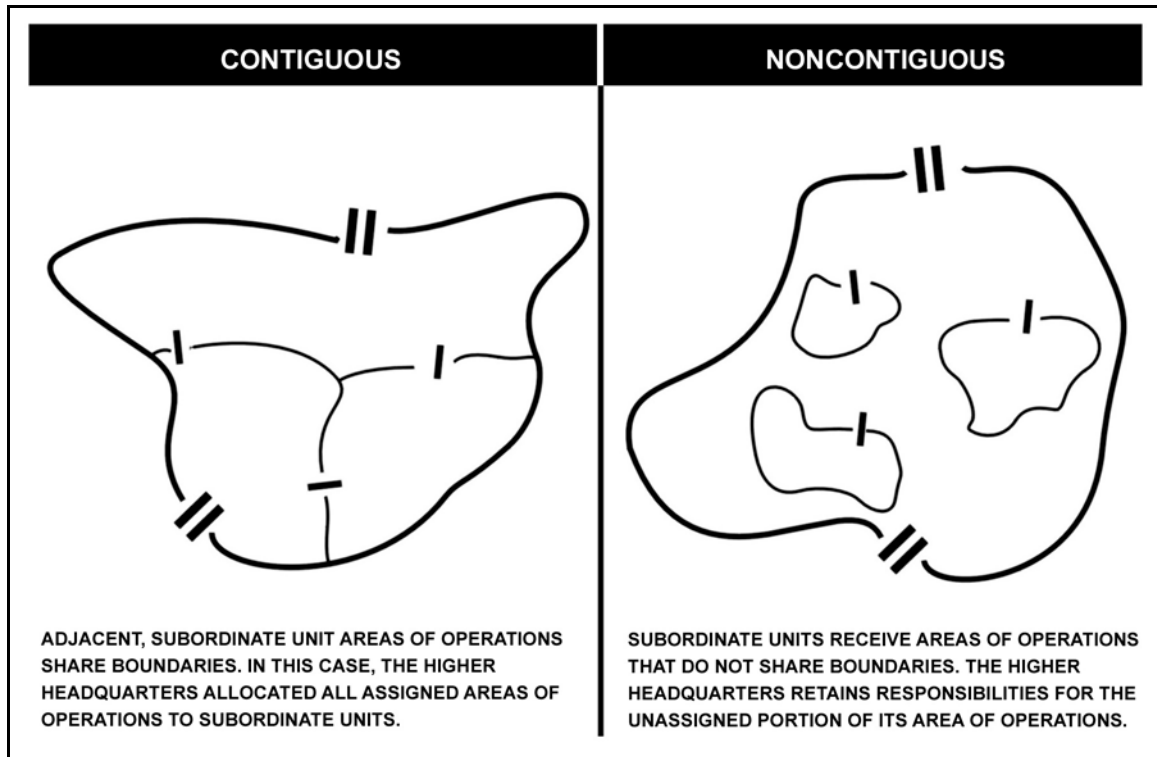
A tank and mechanized infantry task force's AO is the geographical area assigned by a higher commander, including the airspace above, in which the tank and mechanized infantry task force commander has responsibility and the authority to conduct military operations.

a. AOs should allow the commander to employ his organic, assigned, and supporting systems to the limit of their capabilities. The tank and mechanized infantry task force commander normally designates AOs for subordinate units. Commanders use control measures to describe AOs and design them to fit the situation and take advantage of the unit's capabilities. Commanders specify the minimum control measures necessary to focus combat power, delineate responsibilities, assign geographic responsibility, and promote unified action. At a minimum, control measures include boundaries on all sides of the AO.

b. Commanders typically subdivide some or all of the assigned AO by assigning subordinate unit areas. These subordinate AOs may be contiguous or noncontiguous (see Figure 1-2). When friendly forces are contiguous, a boundary separates them. When friendly forces are noncontiguous, the concept of operation links the elements of the force, but the AOs do not share a boundary. The intervening area between noncontiguous AOs remains the responsibility of the higher headquarters.

### **1-5. AREA OF INTEREST**

The tank and mechanized infantry task force's area of interest (AI) is a geographical representation of the area from which information and intelligence are required to execute successful tactical operations and to plan for future operations. It includes any threat forces or characteristics of the battlefield environment that will significantly influence accomplishment of the command's mission. A higher commander does not assign the AI. The AI is developed by the tank and mechanized infantry task force commander and his staff to help visualize the battlefield and determine information requirements.



**Figure 1-2. Contiguous versus noncontiguous.**

## 1-6. BATTLESPACE

Battlespace is the environment, factors, and conditions that must be understood to successfully apply combat power, protect the force, and complete the mission. Battlespace includes land, air, sea, space, enemy and friendly forces, facilities, weather, terrain, the electromagnetic spectrum, and the information environment within the AO and AI.

a. Battlespace is conceptual--a higher commander does not assign it. Commanders determine their battlespace based on their concept of operations. Commanders use their experience, professional knowledge, and understanding of the situation to visualize and change their battle space as current operations transition to future operations. Battlespace visualization begins with a picture of the ground and successively layers enemy, friendly, and environment over terrain visualization.

b. Battlespace is not synonymous with AO. Commanders visualize their battlespace to analyze all the factors that may impact on current and future operations, even if they can only directly affect those factors inside their AO. By defining his battlespace, and in particular, his AI, the commander can focus his intelligence and intelligence operations.

## 1-7. BATTLEFIELD ORGANIZATION

Commanders visualize their battlespace and determine how to arrange their forces.

a. Battlefield organization is the arrangement of subordinate forces according to purpose, time, and space to accomplish a mission. The purpose-based framework centers on decisive, shaping, and sustaining operations. Purpose unifies all elements of the battlefield organization by providing the common focus for all actions. However, forces act in time and space to accomplish a purpose.

b. Tank and mechanized infantry task force commanders may organize forces according to purpose by determining whether each unit's operation will be decisive, shaping, or sustaining. Alternatively, commanders may organize forces by determining main effort and supporting effort(s). The commander chooses the technique to articulate his organization of forces based on which best facilitates his ability to visualize, describe, and direct actions at the tactical level. These decisions form the basis of the concept of operations. Commanders also synchronize operations in time and space. These thought processes are especially useful in combat operations that are generally contiguous, linear, and feature a clearly defined enemy force.

### **1-8. DECISIVE OPERATIONS**

Decisive operations directly achieve the mission and intent of the higher headquarters.

a. Decisive operations conclusively determine the outcome of battles and engagements. There is only one decisive operation for any phase of an operation for any given echelon. The decisive operation may include multiple actions conducted simultaneously throughout the depth of the AO. Commanders weight the decisive operation while economizing on the effort allocated to shaping operations.

b. In the offense and defense, decisive operations normally focus on maneuver. Conversely, logistics may be decisive during the mobilization and deployment phases of an operation or in support operations, particularly if the mission is humanitarian in nature.

c. A reserve is a portion of a body of troops that is kept to the rear or withheld from action at the beginning of an engagement but is available for a decisive movement. Until committed, reserves shape through their placement within the AO while planning for and preparing to conduct operations. When committed, they either become or reinforce the decisive operation. Commanders can use reserves to influence circumstances or exploit opportunities. When commanders anticipate uncertainty, they hold a greater portion of the force in reserve, posturing the force to seize and maintain the initiative as a situation develops. Reserves deploy and reposition as necessary to ensure their protection, availability, and prompt reaction (see Chapters 5 and 6).

### **1-9. SHAPING OPERATIONS**

Shaping operations create and preserve the conditions for the success of the decisive operation. Shaping operations include lethal and nonlethal activities conducted throughout the AO.

a. Shaping operations support the decisive operation by affecting the enemy's capabilities and forces or influencing the opposing commander's decisions. Shaping operations use the full range of military power to neutralize or reduce enemy capabilities. They may occur simultaneously with, before, or after initiation of the decisive operation. They may involve any combination of forces and can occur throughout the depth of the AO. Some shaping operations, especially those that occur simultaneously with the decisive operation, are economy-of-force actions. If the force available does not permit simultaneous decisive and shaping operations, the commander sequences shaping operations around the decisive operation. A shaping operation may become the decisive operation if circumstances or opportunity demand. In that case, commanders weight the

new decisive operations at the expense of other shaping operations. The concept of the operation clearly defines how shaping operations support the decisive operation.

b. Security is an important shaping operation. Security enables the decisive operation of the next higher headquarters. Security protects the force and provides time for friendly forces to react to enemy or hostile activities. It also blinds the enemy's attempts to see friendly forces and protects friendly forces from enemy observation and fires.

### **1-10. SUSTAINING OPERATIONS**

The purpose of sustaining operations is the generation and maintenance of TF combat power.

a. Sustaining operations are operations at any echelon that enable shaping and decisive operations by providing CSS, rear area security, movement control, and terrain management. Sustaining operations include the following elements.

(1) CSS sustains combat power by providing essential capabilities, functions, activities, and tasks necessary to sustain all elements of the operating forces. CSS encompasses those activities at all levels of war that generate and maintain forces on the battlefield.

(2) Rear area security includes measures taken by a military unit, an activity, or an installation to defend and protect itself against all acts that may impair its effectiveness.

(3) Movement control includes the planning, routing, scheduling, controlling, and security of personnel and materiel moving into, within, and out of the AO. Maintaining movement control and keeping lines of communication (LOCs) open are critical requirements in preserving freedom of movement throughout the AO.

(4) Terrain management includes the process of allocating terrain, designating assembly areas, and specifying locations for units and activities.

b. Sustaining operations are inseparable from decisive and shaping operations, although they are not by themselves decisive or shaping. Failure to sustain normally results in mission failure. Sustaining operations occur throughout the AO, not just within the rear area. Sustaining operations determine how fast forces reconstitute and how far forces can exploit success. At the tactical level, sustaining operations underwrite the tempo of the overall operation; they assure the ability of the TF to take immediate advantage of any opportunity.

### **1-11. MAIN EFFORT**

Within the battlefield organization of decisive, shaping, and sustaining operations, commanders designate and shift the main effort.

a. The main effort is the activity, unit, or area that the commander determines constitutes the most important task at that time. Commanders weight the main effort with resources and priorities. Within shaping and decisive operations, the brigade commander may designate a main effort for each operation; however, he will designate only one main effort per operation and shift the main effort as circumstances and intent demand.

b. The main effort and the decisive operation are not always identical. Identification of the main effort in shaping operations is a resource decision. A shaping operation may be the main effort before execution of the decisive operation. However, the decisive operation becomes the main effort upon execution. Shifting the main effort does not

normally require changing or adjusting the plan. Commanders anticipate shifts of main effort throughout the operation. In contrast, changing the decisive operation from the plan requires execution of a branch, sequel, or new plan.

---

## CHAPTER 2

# ORGANIZATION AND CAPABILITIES

*Tank and mechanized infantry battalions are organized to fight and win the nation's wars, but they are equally capable of operating in an unstable environment as part of a joint task force or multinational force. The battalion task force combines the efforts of its combat, combat support, and combat service support elements to perform tactical missions as part of a brigade or division operation. The key to victory is to mass the combat power of the company teams quickly while integrating and synchronizing the combat support and combat service support combat multipliers.*

*A task force can be a temporary grouping of units under one commander, formed for the purpose of carrying out a specific operation or mission, or a TF can be a semipermanent organization of units under one commander for the purpose of carrying out a continuing specific task. Units, regardless of attachments, may be designated as "task forces" whenever they are on a semi-independent mission. A battalion-size unit of the combat arms is called a "battalion task force" when one or more company-size units from another combat arms unit (or from a combat support unit) are attached.*

### **Section I. ORGANIZATION, CAPABILITIES, AND LIMITATIONS**

Mechanized infantry battalion task forces and tank battalion task forces organize, equip, and train to accomplish comparable missions. Across the spectrum of operations, there is an overlap in which both tank and mechanized and light forces can operate. The use of a mixed force in this overlap takes advantage of the strengths of both forces and offsets their respective weaknesses. (Refer to Appendix A for a detailed discussion of heavy and light forces integration and operations.) The following section describes the armor and mechanized infantry TF's unique missions, organizations, capabilities, and limitations.

#### **2-1. ORGANIZATION**

Mechanized infantry (Figure 2-1, page 2-2) and armor (Figure 2-2, page 2-3) battalions are organized, manned, and equipped to conduct high intensity combat operations continuously (see Appendix D, Section III, for information on the effects of continuous operations). Leaders organize TFs according to their directed missions and routinely augment them to improve intelligence, fire support, engineer, air defense, and CSS capabilities. A battalion task force most often accomplishes its tasks and purposes as part of a brigade operation. Occasionally, however, a battalion task force conducts operations directly under the control of a division or armored cavalry regiment.



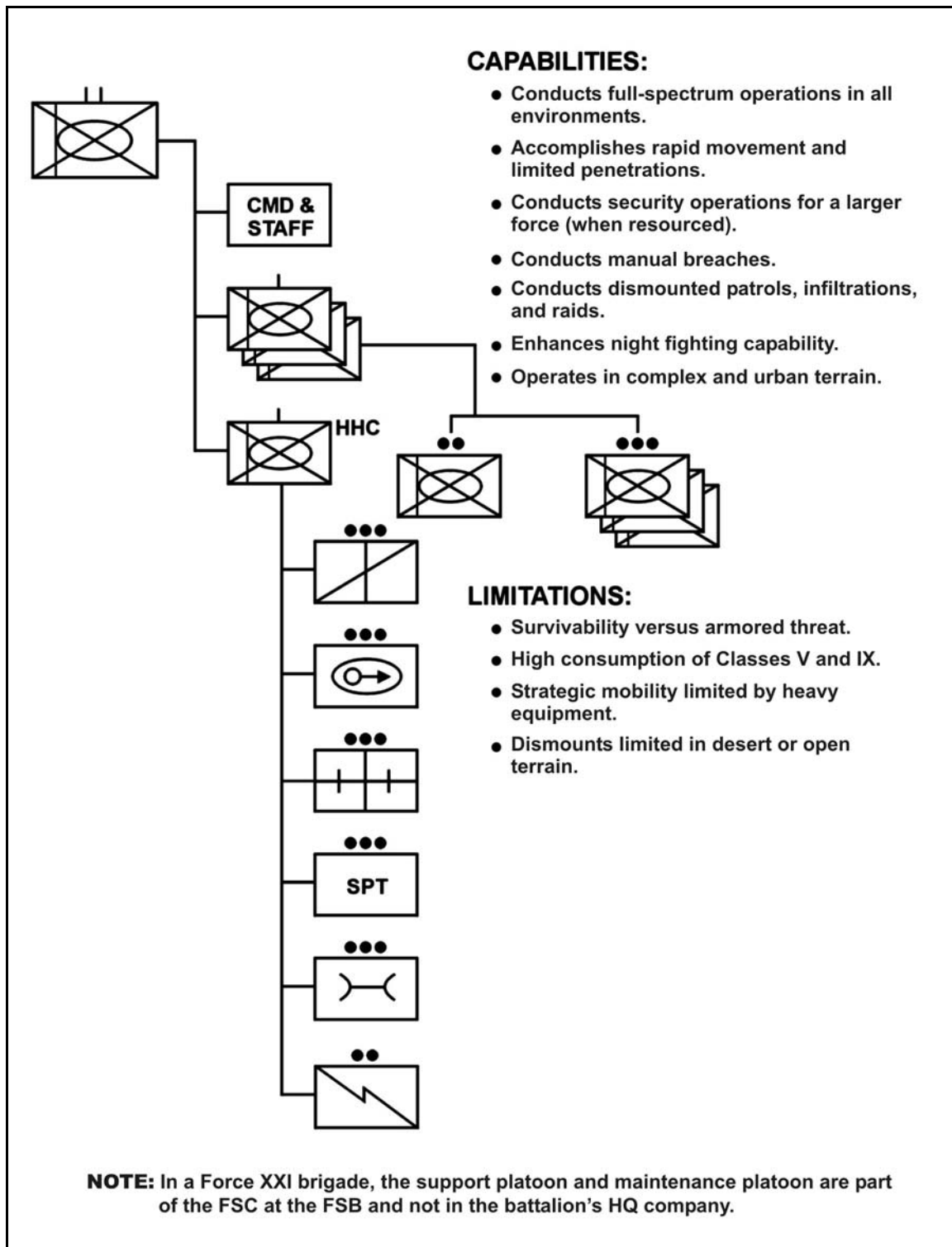


Figure 2-1. Mechanized infantry battalion task force organization.

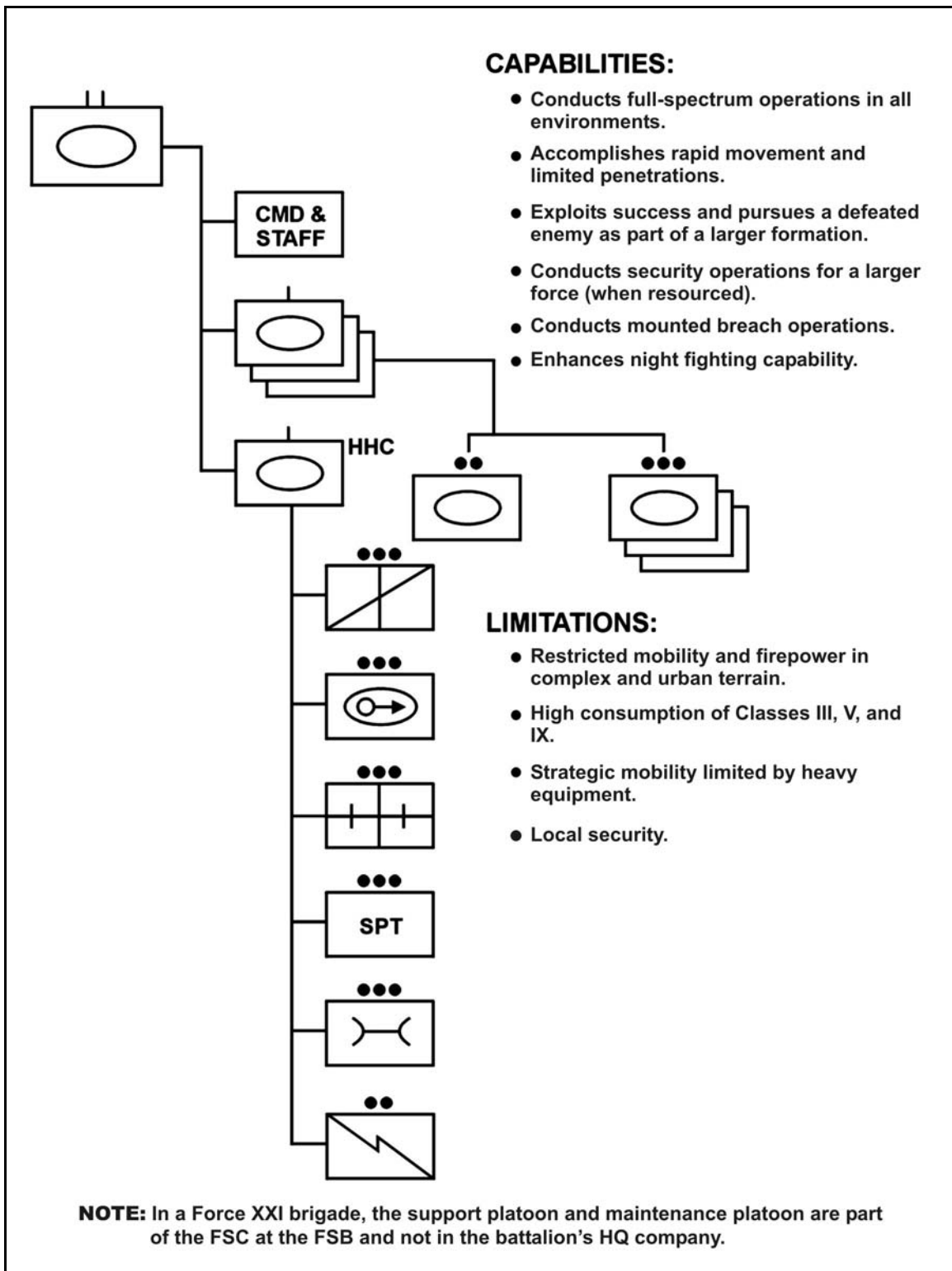


Figure 2-2. Tank battalion task force organization.

## 2-2. CAPABILITIES

Tank and mechanized infantry battalion task forces apply their combat power to--

- Conduct sustained combat operations in all environments with proper augmentation and support.
- Conduct offensive operations.
- Conduct defensive operations.
- Accomplish rapid movement and limited penetrations.
- Exploit success and pursue a defeated enemy as part of a larger formation.
- Conduct security operations (advance, flank, or rear guard) for a larger force.
- Conduct stability operations and support operations as part of a larger force.
- Conduct operations with light infantry forces.

Task organization increases the capabilities of the tank and mechanized infantry battalion task forces. The brigade commander task-organizes tank and mechanized infantry battalion task forces by cross-attaching companies between them. This cross-attachment is generally done at the battalion level because battalions have the necessary command, control, and support capabilities to employ combined arms formations. The brigade commander determines the mix of company teams in a battalion task force. Similarly, the TF commander may require cross-attachment of platoons to form one or more company teams for specific missions.

## 2-3. LIMITATIONS

Tank and mechanized infantry battalion task forces have the following limitations:

- Strategic lift requirements slow the deployment of mechanized and armored forces from home or staging bases into an AO.
- The high density of tracked and wheeled vehicles limits the maneuver and firepower of TFs, particularly in urban areas, dense jungles and forests, steep and rugged terrain, and large water obstacles.
- Consumption of supply items is high, especially Classes III, V, and IX.

## 2-4. TASK FORCE BATTLEFIELD FOCUS

The battalion task force is the lowest echelon at which intelligence, fire support, maneuver, combat support, and combat service support are combined under a single commander. Mechanized infantry and armored task forces provide mobile, armor-protected firepower for the TF's mobility, survivability, lethality, and psychological effect on the situation. A TF uses part of the force to find and fix the enemy while the remainder of the force attacks his weakest point--usually a flank or rear. The goal is to mass combat power at the decisive point to accomplish the TF's purpose while preserving freedom of maneuver for future operations.

a. **Offensive Focus.** During the offense, the TF masses its combat power to defeat a defending enemy force. The close fight consists of breaching tactical and protective obstacles and defeating enemy forces above- and below-ground. Following any penetration, the TF prepares to fight enemy reserves. The TF responds to threats to its rear as part of the close fight. Designated reserves react to changing situations and exploit successes. During the TF close fight, the brigade conducts its deep fight against enemy reserves, then attacks enemy units defending in subsequent defensive positions.

b. **Defensive Focus.** During the defense, the TF defends against and defeats enemy forces. The TF responds to defensive rear threats as part of the close fight and employs defensive security measures in concert with the brigade plan. The brigade deep fight supports the TF close fight by interdicting follow-on enemy battalions, then shifting to the lead unit's battalions of the second echelon formations. The TF does not have the capability or assets to conduct the deep fight; however, it can operate as part of a higher headquarters deep fight by executing the fight against follow-on enemy battalions.

c. **Stability and Support Focus.** Stability operations and support operations are two distinct and different operations. They are seldom short-term. Rather, commanders envision simultaneous activities and sequential stages that lead to a long-term outcome. For example, operations may begin with an initial objective of observing a cease-fire, then move to supporting an economic recovery program, and finally conclude with supporting an international agency program for cultural assimilation and resolution of the underlying conflict. (See Chapters 8 for more information on these operations.)

d. **Commander's Focus.** The objectives of maneuver are to position friendly forces' strengths against enemy weaknesses, to protect friendly weaknesses from enemy strengths, to throw the enemy off balance, and to follow up aggressively to complete the destruction of the enemy. The TF commander develops his intent and concept of the operation nested within the framework of the higher commander's intent. The TF commander must clearly understand how his mission-essential tasks and purposes fit into the intent of the brigade and division commanders. Since he will have to accept some risk in order to mass combat power at the critical place or time--whether in the offense or defense--this understanding will enable him to seize the initiative when opportunity allows.

## **Section II. DUTIES AND RESPONSIBILITIES OF KEY PERSONNEL**

A tank or mechanized infantry battalion task force consists of task-organized company teams under the command of a TF commander. It participates in brigade or division operations in accordance with the principles and concepts in FM 3-90.3 and FM 71-100.

### **2-5. TASK FORCE COMMANDER**

The TF commander is responsible for everything his unit does or fails to do. He cannot delegate this responsibility. The commander is responsible to both his superiors and his subordinates. He increases the effectiveness of the organization by delegating to his subordinates the authority to accomplish their missions, holding subordinates responsible for their actions, and fostering a climate of mutual trust, cooperation, and teamwork. He organizes his force based on the mission of the higher headquarters and a thorough understanding of his mission, enemy, terrain (and weather), troops and support available, time available, and civil considerations (METT-TC).

### **2-6. PERSONAL STAFF GROUP**

The commander's personal staff group consists of the command sergeant major (CSM) and battalion task force chaplain.

a. **Command Sergeant Major.** The CSM is the senior noncommissioned officer (NCO) in the TF. He focuses on soldier welfare and individual training and on how well the TF carries out the commander's decisions and policies. The CSM can act as the

commander's representative in supervising aspects vital to an operation, as determined by the commander. For example, he can help control movement through a breach in a critical obstacle or at a river crossing, or he can help coordinate a passage of lines or quarter assembly areas. He also plays a key role in the CSS effort as the CSS troubleshooter for the TF.

b. **Battalion Task Force Chaplain.** The chaplain coordinates the religious assets and operations in the TF.

(1) The chaplain's specific responsibilities include--

- Advising the commander on issues of religion (and ethics and morals as affected by religion), including the religious needs of assigned personnel.
- Providing commanders pastoral care, personal counseling advice, and the privilege of confidentiality and sacred confidence.
- Developing and implementing the commander's religious support program.
- Exercising staff supervision and technical control over religious support throughout the TF.
- Helping the commander ensure all soldiers have the opportunity to exercise their religious beliefs constructively.
- Informing the commander on the overall morale and climate of the task force.

(2) The battalion chaplain assistant's responsibilities are--

- To advise the chaplain.
- To provide specialized assistance in areas of religious support.
- To serve as section battle staff.
- To prepare the religious support annex to the OPORD.
- To safeguard and account for field offerings.
- To maintain unit equipment.

## 2-7. COORDINATING STAFF AND ORGANIZATIONS

During the preparation for and execution of operations, staff officers have two broad areas of responsibility. The first is to provide information, assistance, and recommendations to the commander. The second is to supervise the preparation for and execution of the plan within their functional areas. Specific responsibilities include anticipating requirements, monitoring operations, taking action to support the plan, managing the information flow, making timely recommendations, conducting coordination, synchronizing operations, and maintaining continuity. The coordinating staff includes the executive officer (XO), S1, S2, S3, S4, and S6. In some instances, the TF may also be authorized an S5 to aid in civil-military operations (CMO). (For additional information, see FM 101-5. Knowledge of the commander's intent guides specific decisions within the staff's authority. The staff operates to carry out the commander's intent functionally. Normally, the commander delegates authority to the staff to take final action on matters within command policy. Assignment of staff responsibility does not include authority over other staff officers or over any command element.

a. **Executive Officer.** The XO is the principal assistant to the TF commander. As the second in command, the XO must be ready to assume command immediately if the

commander becomes a casualty. The XO transmits the commander's intent for the TF. His two main responsibilities are to direct the efforts of the TF staff and to sustain the TF.

(1) **Staff Coordination and Synchronization.** The XO is the staff coordinator and establishes staff operating procedures. He ensures the commander and staff are informed on matters affecting the command. To coordinate and synchronize the plan, the XO assembles and supervises the staff during the military decision-making process (MDMP). Unless instructed otherwise by the commander, all staff officers inform the XO of any recommendations or information they give directly to the commander or any instructions they receive directly from the commander.

(2) **Logistics.** The XO's second responsibility is to synchronize the TF's logistical support. Depending on the unit's organization, this synchronization may take place with internal assets or through the forward support battalion (FSB).

b. **S1 Adjutant.** The S1 has responsibility for all personnel and administrative matters.

(1) The S1 adjutant--

- Maintains unit strength and personnel services and personnel support.
- Supervises medical, legal, safety, and civilian labor assets.
- Monitors postal services and public affairs.
- Coordinates religious support.
- Operates from the combat trains.
- Repositions as necessary to accomplish his mission.

In addition, the S-1 adjutant is responsible for--

- Replacement policies and requirements.
- Unit strength and loss estimation.
- Morale and welfare support.
- TF administration.
- Administrative support of enemy prisoners of war (EPWs) and civilian internees.
- Casualty evacuation planning and supervision.

The S-1 adjutant also shares supervisory responsibility for logistical operations with the S4.

(2) The S1 NCO provides technical and doctrinal advice to the S1 and commander.

The S1 NCO--

- Supervises the combat service support control system (CSSCS) and standard installation/division personnel system (SIDPERS) operations
- Serves as shift NCO in charge (NCOIC) for rear command post (CP).
- Executes personnel administrative and replacement operations to include soldier recognition and promotion and reduction actions.
- Executes awards and evaluations program.

c. **S2 Intelligence.** The S2 collects and applies intelligence to support TF operations.

(1) **S2 Officer.** The S2's role in target analysis and his linkage with the S3 and fire support officer (FSO) are vital to mission accomplishment. The S2--

- Works with the commander and S3 to perform intelligence preparation of the battlefield (IPB) using higher collection sources, ground and aerial reconnaissance, observation posts, ground surveillance radar (GSR), target acquisition and electronic warfare assets, and company teams.
- Prepares and disseminates intelligence products.
- Recommends to the commander priority intelligence requirements (PIR) and generates other information requirements (IR).
- Obtains and disseminates weather information and predicts (with the chemical officer) the probability of use and effects of enemy nuclear, biological, and chemical (NBC) weapons.
- Supervises counterintelligence efforts, intelligence training, and storage and control of classified information.
- Operates in the main CP and assists the XO and S3 in monitoring ISR operations
- Maintains the enemy situation map and analyzes enemy information.
- Assists the S3 in planning ISR operations.
- Works closely with the FSO and assistant S3 to ensure information is passed between staff sections.
- Supervises supporting intelligence organizations when attached.
- Monitor and maintains the required investigations, clearances, authorizations, and the need to know for digital command and control users.

(2) **Tactical Intelligence Officer.** The tactical intelligence officer (TIO) works under the supervision of the S2 and is part of the two-man battlefield information control center (BICC). The TIO--

- Performs unit intelligence collection, processing, and dissemination actions as tasked by the S2.
- Locates in the main CP.

(3) **S2 NCO.** The S2 NCO provides technical and doctrinal advice to the S2 and commander. The S2 NCO--

- Supervises and trains all-source analysis system (ASAS) operators.
- Serves as shift NCOIC for main CP.
- Executes the battalion's command security programs.
- Attends targeting meetings.
- Assists the S2 in product preparation.

d. **S3 Operations and Training Officer.** The S3 is the commander's primary assistant in planning and coordinating operations. The S3--

- Advises the commander on operations, CS and operational matters, organization, and training.
- Prepares the operation order (OPORD) in cooperation with the other staff members and, in the XO's absence, coordinates and synchronizes the battle plan and supervises the staff during the MDMP.
- Plans and coordinates with other staff sections to publish operation orders, fragmentary orders (FRAGOs), and training programs.
- Integrates and synchronizes all battlefield operating systems (BOS) into the tactical plan.

- Establishes priorities for communications to support tactical operations.
  - Coordinates with the XO and S6 on the location of the main CP.
  - Coordinates the activities of the S2, FSO, forward air controller (FAC), engineer, and air defense officer (ADO) to ensure their plans support the commander's concept.
  - Coordinates closely with the S4 and headquarters and headquarters company (HHC) commander or the forward support company (FSC) commander to ensure tactical plans are logistically supportable.
  - Remains forward with the commander during the fight.
  - Monitors the battle, ensures CS assets are provided when and where required, and anticipates developing situations.
  - Provides the commander information that has immediate impact on the battle.
  - Recommends courses of action to the commander.
- (1) **S3 Air.** The S3 air is the primary assistant to the S3. The S3 air--
- Acts as the link to the Army airspace command and control (A2C2) system.
  - Coordinates use of TF airspace and employment of air support with the FSO, tactical air control party (TACP), aviation liaison officer (if attached), and the air defense element. (See Appendix B for a discussion of Army aviation employment.)
  - Locates in the main CP.
  - Coordinates air movement operations.
  - Is the primary assistant to the S3 during the MDMP, especially during course of action (COA) development and analysis.
  - Participates in TF rehearsals.
  - Acts as the TF battle captain during mission execution; helps the XO coordinate the fight.
  - Assumes the S3's duties and responsibilities in his absence.
- (2) **S3 Liaison Officer.** The S3 liaison officer (LNO) is the primary assistant to the S3 Air. The S3 LNO--
- Assists the S3 air as link to the Army airspace command and control (A2C2) system.
  - Acts as the link to ground units that require coordination directed from the TF operations staff
  - Locates in the main CP.
  - Assists S3 air in coordinating air movement operations.
  - Assists the S3 air in planning and executing the MDMP to include course of action development and analysis.
  - Participates in TF rehearsals.
  - Assumes the S3 air's planning duties and responsibilities in his absence.
- (3) **Chemical Officer.** The chemical officer (CHEMO) advises the commander on the impact of NBC employment on current and future operations. (See Appendix C for more information on NBC conditions.) The chemical officer--
- Develops the enemy's most probable use of NBC weapons and their effects on TF operations.



- Disseminates friendly strike warning (STRIKEWARN) messages on use of nuclear weapons.
  - Recommends reconnaissance, monitoring, and surveying requirements.
  - Recommends mission-oriented protective posture (MOPP) and operational exposure guidance (OEG) based on the threat analysis and higher headquarters guidance.
  - Maintains unit radiological dose records (by platoon).
  - Conducts vulnerability analyses of the unit's positions.
  - Plans TF decontamination operations (in conjunction with S3).
  - Coordinates nonorganic NBC assets (decontamination, smoke, and reconnaissance).
- (4) **S3 SGM.** The S3 SGM acts as main CP NCOIC. The S3 SGM--
- Provides technical and doctrinal advice to the S3 and commander.
  - Is chief advisor to XO and S3 concerning main CP operations during planning, preparation, and execution.
  - Locates in the main CP where he can best influence operations.
  - Is responsible for the physical set up, arrangement, and breakdown of the main CP.
  - Is responsible for the movement of the main CP.
  - Supervises all TOC personnel to include section NCOICs.
  - Supervises maneuver control system (MCS) operators.
  - Prepares main CP for orders, drills, briefs, and rehearsals.
  - Executes CP security.
  - In coordination with (ICW) TF XO, executes main CP site reconnaissance and movement.
  - Coordinates the logistical needs of the main CP.
- (5) **S3 NCO.** The S3 NCO acts as battle NCO. The S3 NCO--
- Provides technical and doctrinal advice to the S3 and commander.
  - Serves as shift NCOIC for main CP.
  - Supervises MCS operators.
  - Prepares main CP for orders, drills, briefs, and rehearsals.
  - Executes CP security and movement.
  - Briefs attachments on TOC standing operating procedures (SOPs).
- (6) **Chemical NCO.** The chemical NCO provides technical and doctrinal advice to the CHEMO and commander. The chemical NCO--
- Serves as shift NCOIC for main CP.
  - Sustains and maintains the battalions chemical defense equipment.
  - Executes NBC reporting procedures.
  - Liaisons with supporting chemical decontamination units.
- e. **S4 Logistics.** The S4 determines logistical requirements and priorities and ties the administrative/logistical (A/L) network together.
- (1) **S4 Logistics Officer.** The S4 logistics officer--
- Designates supply routes and locations of logistical elements (in coordination with the S3).

- Prepares and develops logistical CSS plans in concert with the current tactical plan and anticipates future logistical needs.
- Prepares and distributes logistical CSS plans and orders when published separately.
- Is the officer in charge (OIC) of the combat trains command post (CTCP) in Army of Excellence (AOE) organizations. The CTCP is an alternate TF main CP.
- Monitors the tactical situation closely to anticipate emergency resupply requests and support timely reorganization.
- Pushes ammunition, food, fuel, and other supplies forward to resupply the TF.
- Is responsible for procurement, receipt, storage, and distribution of supplies.
- Is responsible for transportation of units, soldiers, and logistics items.
- In AOE/limited conversion design (LCD) units, the S-4 is the OIC of the CTCP. In Force XXI organizations, the S-4 locates in the CTCP and acts as the chief logistics planner

(2) **S4 Logistics NCO.** The S4 logistics NCO provides technical advice to the S4 and the commander. The S4 logistics NCO--

- Supervises CSSCS and unit-level logistics system (ULLS) S4 operations.
- The S-4 NCO locates in the TF field trains in AOE/LCD organizations and in the task force support area (TFSA) in Force XXI-configured units.
- Acts as shift NCOIC for rear CP.
- Maintains logistics estimates.
- Executes Class VII replacement.

(3) **Support Platoon (Supply and Transportation [S&T] in Platoon Force XXI).** The support platoon provides organic transportation and Class I, III, and V resupply to the TF. (For details on classes of supply, see Chapter 10.) The support platoon consists of a platoon headquarters, transportation section, ammunition section, petroleum, oil, lubrication (POL) section, and a food service section. The platoon provides the majority of the TF's combat service support. In Force XXI-configured units, the support platoon is assigned to the FSC. In AOE units, it is organic to the TF HHC.

f. **Battalion Task Force Maintenance Officer (BMO).** The BMO plans, coordinates, and supervises maintenance and recovery operations within the TF. The BMO--

- Supervises the maintenance platoon.
- Controls maintenance support and establishes time guidelines for the maintenance platoon ICW the battalion task force maintenance technician and the battalion task force motor sergeant.
- Shifts assets to respond to workload demands and the TF commander's priorities.
- Structures maintenance assets to meet TF requirements.
- Acts as OIC of the unit maintenance collection point (UMCP).

The maintenance platoon is structured to maintain, evacuate, and repair TF vehicles. As the largest platoon in the TF, it is organized into a platoon headquarters, a maintenance supply section, a recovery section, a maintenance/service section, and a company

maintenance section. In Force XXI-configured units, the maintenance platoon is assigned to the FSC; in AOE units, it is organic to the TF HHC.

g. **S5 Civil Affairs Officer.** The civil affairs officer is the principal staff officer for all matters concerning civil-military operations. He advises the commander on the impact of military operations on the civilian populace and the impact of civilians on military operations. He is responsible for establishing the civil military operations center (CMOC). The CMOC enhances the relationship between military forces and civilians in the AO to help ensure the success of the mission. For additional information, see FM 3-05.40 (41-10).

h. **S6 Signal Officer.** The battalion task force signal officer is the primary staff officer for all matters of signal operations and information security for the TF. The signal officer--

- Advises the commander and staff on all signal matters.
- Supervises the communications activities of subordinate and attached units.
- Leads the communications section.
- Exercises technical supervision over the installation and use of communication systems.
- Recommends location for retransmission (retrans) sites
- Reconnoiters possible CP sites for communications capabilities.
- Recommends locations for the main CP and combat trains CPs to the S3.
- Establishes messenger services and schedules.
- Monitors communications security (COMSEC).
- Maintains information systems and tactical local area network (LAN) management to include passwords and information security.
- Is responsible for secure operations of the information systems (INFOSYS) and oversees function of the information services support office (ISSO) and automation officer.
- Prepares, distributes, and maintains plans, instructions, guidance, and SOPs for command and control (C2) security.
- Coordinates with the S2 to insure users have the required security investigations, clearances, authorizations, and the need to know.
- Establishes and implements the system of issuing, protecting, and changing system passwords.

The communications section establishes and operates the TF radio and wire communications systems. It can set up retransmission nodes and perform limited field repair and testing of communications equipment. The section provides forward signal support NCOs to the company teams.

i. **Surgeon.** The surgeon (in his absence the physician's assistant) is the medical advisor to the commander and his staff and is also the medical platoon leader. The surgeon--

- Advises the commander on the health of the command.
- Oversees medical treatment provided by the medical platoon personnel.
- Operates the battalion aid station (BAS) with the help of the physician's assistant.

As the platoon leader, the surgeon supervises the medical platoon in the execution of its assigned mission, to include HSS planning, maintenance, and training. He is responsible for providing HSS input to the CSS plan, he recommends casualty collection points (CCPs) and aid station locations, ensures coordination for air evacuation support, and provides evacuation routes to the battalion S4 during the battle.

(1) **Field Medical Assistant.** The field medical assistant, a medical service corps officer, is the operational and readiness officer for the platoon. He is the principal assistant to the surgeon/platoon leader for operations, training, and logistics. The field medical assistant coordinates HSS operations with the battalion S3 and S4 and coordinates patient evacuation with the forward support medical company (FSMC).

(2) **Medical Platoon.** The medical platoon (Figure 2-3, page 2-14) provides combat health support for the battalion. The medical platoon is organized with a headquarters section, a treatment squad, a combat medic section, and an evacuation section. The medical platoon is responsible for providing echelon I medical care. The first medical care a soldier receives is found at echelon I. This care includes emergency medical treatment for wounds, injuries or illness, and advanced trauma management. It also includes disease prevention, combat stress control, casualty collection, medical evacuation from the supported maneuver company to the battalion aid station or supporting treatment team, and sick call services. Medical platoon personnel monitor the force health protection areas for battalion personnel. The medical platoon habitually establishes the BAS where it can best support the battalion's operations under the directions of the battalion TOC and the CTCP. Trauma specialists from the combat medic section are attached to each of the company maneuver platoons and a senior health care sergeant locates with the company trains. Medical platoon ambulances normally pre-position forward to reduce evacuation time and to augment medical personnel attached to the maneuver companies as required. The battalion surgeon, assisted by the field medical assistant and the platoon sergeant, is responsible for the HSS plan for the battalion. As operational requirements or the mission changes, the HSS plan must be updated. See FM 4-02.4 for definitive information on developing the battalion HSS plan and for a layout of the battalion aid station.

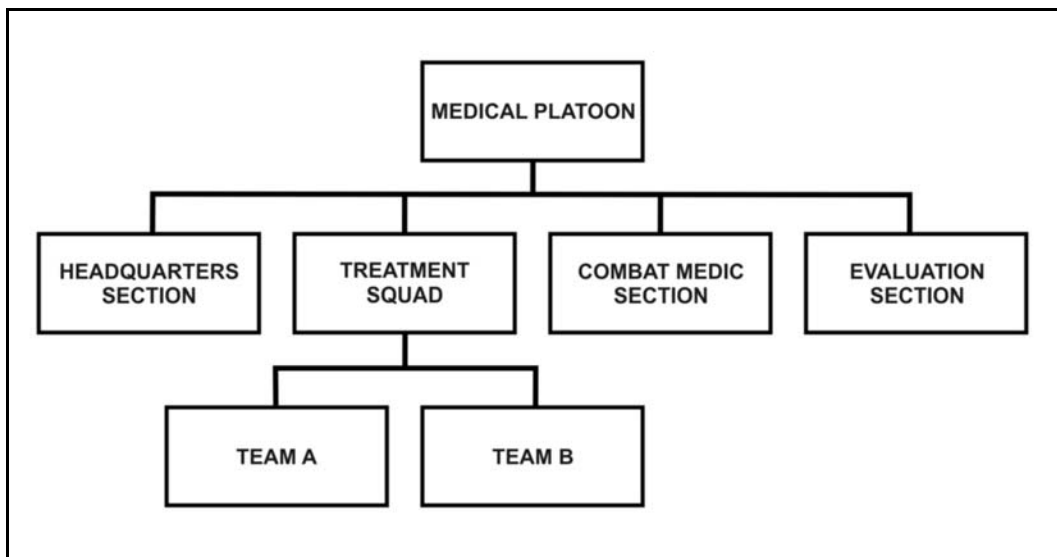
(a) **Platoon Headquarters.** The headquarters section, under the direction of the battalion surgeon/medical platoon leader, provides for the command, control, and communications (C3) and resupply for the platoon. The platoon headquarters is manned by the field medical assistant and the platoon sergeant (PSG). It is normally collocated with the treatment squad to form the BAS. The CP includes the plans and operations functions performed by the field medical assistant. The platoon has access to Force XXI battle command brigade and below (FBCB2), the battalion wire communication network for communications with all major elements of the battalion and with supporting units. Wireless communications for this section consists of a tactical frequency modulated (FM) radio mounted in the platoon headquarters vehicle. The medical platoon employs an FM radio network for HSS operations. The headquarters section serves as the net control station (NCS) for the platoon.

(b) **Treatment Squad.** The treatment squad consists of two treatment teams (Teams Alpha and Bravo). They operate the BAS and provide Echelon I medical care and treatment. This includes sick call, emergency medical treatment (EMT), and advanced trauma management (ATM). Team Alpha is staffed with an operational medicine officer

(primary care physician/battalion surgeon), a health care SGT, and two health care specialists. Team Bravo is staffed with a physician's assistant (PA), a health care sergeant (SGT), and two health care specialists. The physician, PA, and health care SGT and specialists are trained to provide EMT and assist with ATM procedures, commensurate with their occupational specialties. Preplanned triggers initiate treatment team movement to the next planned position; these triggers are key to timely and successful team displacement. The treatment teams can operate for limited times in split-team operations in direct support (DS) of battalion units. The teams can also operate in split-team operations when the BAS must move to a new location. One team remains at the current location and continues to treat patients while the other team moves to the new location and establishes patient care capabilities. Once the jump team has established a treatment capability at the new location, the other team evacuates or returns to duty all patients and moves to the new location. Treatment teams are also responsible for providing area support for other units and elements operating within the battalion's AO.

(c) *Combat Medic Section.* Trauma specialists are allocated to the companies of the task force. With assistance from combat lifesavers, trauma specialists will treat casualties and evacuate them to the CCP and BAS. A health care SGT is allocated on the basis of one per infantry company. The company health care SGT normally collocates with the first sergeant (1SG) in the company team trains. When the company is engaged, he assists in the evacuation of casualties to the CCP and or the BAS as directed by the 1SG. As the tactical situation permits, he may also prepare patients for evacuation by air ambulance.

(d) *Evacuation Section.* Patients are evacuated to the FSMC by FSMC ground ambulances or by corps aeromedical evacuation aircraft.



**Figure 2-3. Medical platoon.**

**2-8. THE HEADQUARTERS AND HEADQUARTERS COMPANY COMMANDER AND THE FORWARD SUPPORT COMPANY COMMANDER IN FORCE XXI ORGANIZATIONS**

The FSC commander's role is the same in Force XXI organizations and AOE organizations. The HHC commander has slightly different roles depending on whether the organization is Force XXI or AOE.

a. The FSC commander is the TF's primary logistics executor in Force XXI organizations. The FSC commander--

- Forms the logistics package (LOGPAC) in the TFSA with the company supply sergeants and the S&T platoon.
- Is the liaison between the TF and FSB.
- Supervises the S&T platoon leader.
- Commands the TFSA.
- Advises the TF commander on supply and support issues.
- Supervises the flow of information between the TFSA and CTCP.

b. The HHC commander has a slightly different role depending on whether he is in a Force XXI organization or an AOE organization.

(1) In Force XXI, the HHC commander--

- Is the OIC of the combat trains and responsible for its security and organization.
- Based on METT-TC, has the flexibility to locate the UCMP, assist in recovery, assist in emergency resupply, and conduct other tasks throughout the task force area of operation.
- Executes logistics forward of the CTCP for specialty platoons and the main command post.
- Assists the BMO in maintenance management to allow the TF XO to coordinate the staff and fight the TF from the main CP.
- Places the HHC XO in the TFSA to advise the FSC commander on TF logistical requirements. The HHC XO retains flexibility to assist in the planning and or execution of other tasks as needed throughout the task force area of operation.

(2) In AOE/LCD organizations, the HHC commander commands the TF field trains. The HHC commander--

- Is the OIC of the field trains command post (FTCP) and responsible for its security and organization.
- Is the TF CSS coordinator.
- Is the TF representative in the brigade support area (BSA).
- Forms the LOGPAC in the field trains with the company or team supply sergeant and the support platoon leader.
- Supervises the support platoon leader.

## **2-9. COMPANY TEAM COMMANDERS**

Company team commanders fight battles by maneuver and firepower. Commanders directly influence the battle by employing their assets to accomplish the mission. They are the TF commander's executors of the plan. They must understand the commander's intent and concept of the operation and be fully versed in the capabilities and employment techniques of the combat power they control. They must be proficient in

employing the CS and CSS assets that the commander may attach to their company teams.

### **2-10. SCOUT PLATOON LEADER**

The scout platoon conducts reconnaissance and security in support of the TF mission. The scout platoon leader advises the commander, S2, and S3 on employing the scout platoon. The platoon also assists in controlling TF movement but rarely conducts independent offensive, defensive, or retrograde operations. The scout platoon consists of a platoon headquarters and two or four sections, depending on the parent unit's organization. The scout platoon assists the commander in planning and executing operations by providing relevant information in a timely fashion during the preparation and execution phase of a mission.

### **2-11. MORTAR PLATOON LEADER**

Mortars are high-angle, relatively short-range, fire support weapons that are organic to the battalion task force. The mortar platoon leader advises the commander, S3, and FSO on employing the mortar platoon. The quick response time of the mortar platoon is well suited for providing close indirect fire support to maneuver units, making them the commander's most responsive indirect fire capability. The platoon consists of two sections of two 120-mm tubes each and has a fire direction center (FDC). The mortar platoon headquarters can also serve as an alternate TF main CP under special circumstances for limited periods of time.

### **2-12. SPECIAL STAFF**

In addition to the organic assets a commander controls, he may receive various supporting units to support his task force. These assets include a wide variety of indirect fires and aviation systems, which may be both divisional and nondivisional. Combat or combat support assets normally available to the TF include--

- Field artillery (FA).
- Close air support (CAS).
- Air defense artillery (ADA).
- Engineers.

a. **Fire Support Officer.** The FSO is an habitually associated officer from the FA battalion in direct support of the brigade. He coordinates all fire support for task force operations and is the fire support coordinator (FSCOORD). The FSO--

- Advises the TF commander and his staff on all fire support matters.
- Develops and recommends high-payoff targets (HPTs) ICW the S2.
- Develops and recommends essential fire support tasks (EFSTs).
- Recommends fire support coordination measures (FSCMs).
- Coordinates indirect fires across boundaries.
- Trains company team FSOs.
- Synchronizes all aspects of the fire support plan ICW the TF S3 during the MDMP.

---

b. **Battalion Task Force Air Liaison Officer (ALO).** The ALO is normally an Air Force officer responsible for coordinating and controlling all close tactical air (TACAIR) support and employment of Air Force assets in support of the TF. The ALO--

- Is responsible for the TACP.
- Assists the commander and S3 in planning the use of available air support.
- Coordinates the employment of air support with the S2, S3, FSO, and air defense element.
- Locates forward with the commander.
- Controls close air support of the TF.

c. **Air Defense Officer.** The leader of the supporting air defense unit serves as the ADO. The ADO--

- Assists the S3 in planning and executing the air defense portion of the operation.
- Advises the commander and S3 on the employment of air defense assets.
- Coordinates with the S3 air, FSO, and brigade air liaison officer (BALO) for the appropriate air defense posture.
- Controls integration of air defense elements and early warning systems.

d. **Engineer Company Commander.** The attached engineer company commander serves two major roles in the TF. First, he serves as the senior engineer and commander of all engineer assets assigned to the TF (whether organic to the engineer company or not). Second, he serves as the TF engineer by providing expertise in terrain analysis and the employment of engineer assets. The engineer company commander—

- Advises the commander on using engineer assets.
- Aids the staff in analyzing terrain, templating enemy obstacles, and coordinating a mobility and countermobility plan to support the scheme of maneuver.
- Maintains continuous communications with the main CP.
- Monitors the TF command net.



---

## CHAPTER 3

# BATTLE COMMAND

*Battle command is the exercise of command in operations against a hostile, thinking enemy. It applies the leadership element of combat power to operations. Principally, battle command is an art that employs skills developed by professional study, constant practice, and considered judgment. Commanders, assisted by staff, visualize the operation, describe it in terms of intent and guidance, and direct the actions of subordinates within their intent. They direct operations in terms of the battlefield operating systems and directly influence operations by their physical presence supported by the command and control system. Command of the task force remains a personal function. The capabilities provided via communications and computers and intelligence, surveillance, and reconnaissance within the C2 system allow rapid sharing of enemy and friendly information among all forces within the area of operation and enhance combat power by making combat forces more lethal and survivable. In addition, digitization provides the commander with an ability to lead and make decisions from anywhere on the battlefield while remaining linked to planning and preparation ongoing in the main CP.*

### **Section I. THE ART OF COMMAND**

Command is the authority that a commander lawfully exercises over subordinates by virtue of rank and assignment. Leaders possessing command authority strive to use it with firmness, care, and skill. Command is more an art than a science, although it exhibits characteristics of both. The "art of command" requires expert performance of a specific skill using intuitive faculties that the leader cannot gain solely by study or education. Command also requires a conscious and skillful exercise of authority to fulfill command responsibilities through decision-making and leadership.

#### **3-1. ROLE OF THE COMMANDER**

The task force commander's knowledge, experience, and personality determine how he interacts with his unit through the C2 system. The commander decides what he needs to do and the best method to do it, and he leads his unit to accomplish the mission. He drives the process through mission command. He establishes a command climate for his unit, prepares his unit for operations, commands his unit during operations, and assesses his subordinates. He establishes a system to meet the unique demands that he places on his unit, the abilities and personalities of his subordinates, and the capabilities of the equipment within the task force. The commander refines the C2 system and operates it based on his personality.

#### **3-2. MISSION COMMAND**

Mission command is the conduct of military operations through decentralized execution based on mission orders for effective mission accomplishment. Mission orders leave the "how" of mission accomplishment to the subordinates by allowing them maximum freedom of planning and action to accomplish missions. Successful mission command

results from subordinate leaders exercising disciplined initiative within the commander's intent to accomplish missions. It requires an environment of trust and mutual understanding. The four elements of mission command are commander's intent, subordinate initiative, mission orders, and resource allocation.

a. **Commander's Intent.** Commander's intent is a clear, concise statement of what key tasks the unit must do and what conditions it must meet to succeed with respect to the enemy, terrain, and the desired end state. The commander formulates and communicates his intent to ensure unity of effort during operations, allowing subordinates to exercise disciplined initiative.

b. **Subordinate Initiative.** Initiative is the assumption of responsibility to decide and initiate independent actions when the commander's concept or order is no longer applicable or when an unanticipated opportunity leading to the accomplishment of the commander's intent presents itself. Subordinates decide how to achieve their assigned missions within the delegated freedom of action and the exercise of disciplined initiative during execution; however, they have an absolute responsibility to fulfill the commander's intent.

c. **Mission Orders.** A mission order is a technique for completing combat orders to allow subordinates maximum freedom of planning and action in accomplishing missions. The commander intervenes to direct coordination, restore operations, or exploit success. At a minimum, mission orders state--

- Task organization.
- Commander's intent and concept of operations.
- Unit mission.
- Subordinate unit missions.
- Mission-essential coordinating instructions.

d. **Resource Allocation.** The commander allocates appropriate resources to subordinates to accomplish their missions. The commander must also consider information and the INFOSYS as resources and allocate them through all levels of his command.

### 3-3. LOCATION OF THE COMMANDER

In the past, commanders have been torn between the conflicting requirement to visualize the battlefield and the requirement for his presence in the main command post to participate in the military decision-making process. This dilemma slowed the planning and execution of operations while frustrating the commander's efforts to "get out of the command post."

a. All commanders within the task force have the ability to visualize their battlespace in all dimensions and to share a common operational picture (COP). Perhaps the largest and most immediate impact of digitization is its effect on the operations process (plan, prepare for, execute, and assess operations). Digitization streamlines planning and preparation by allowing the near-simultaneous transfer of information to all leaders. This transfer of information facilitates parallel planning and preparation. Using digitized equipment should compress the planning cycle for commanders and allow planning at all levels to begin sooner. Task force commanders also have the ability to locate and track targets precisely and conduct simultaneous operations employing lethal and nonlethal means while operating with joint and multinational forces. In addition, task

force commanders retain the ability to recognize and protect their own and other friendly forces. The commander cannot, however, fully visualize the battlefield while directing and synchronizing the efforts of his task force from a computer screen at the main command post. He must move from the main CP to assess the situation face-to-face with subordinate commanders and soldiers. The C2 system within the task force permits a commander to position himself where he can best command without depriving himself of the ability to respond to opportunities and changing circumstances.

b. The commander can be virtually anywhere on the battlefield to best affect ongoing operations without disrupting the planning and preparation for future operations. Near-real-time information updates, continuous assessment, and command decisions can be briefed, approved, and disseminated from task force to company team level via the available INFOSYS with the C2 system.

### **3-4. COMBINING THE ART OF COMMAND AND THE SCIENCE OF CONTROL**

The commander is the key to command and control within the task force. Foremost among his roles is his ability to combine the art of command and the science of control. He must use a methodology of visualizing the battlespace, describing his visualization to subordinates, directing action to achieve results, and leading the unit to mission accomplishment while conducting continuous assessment throughout the mission.

a. **Visualize.** The commander's visualization (Figure 3-1, page 3-4) is the core mental process that supports his decision-making and by which he combines the art of command and the science of control. It is the process of achieving a clear understanding of the current state of the task force with relation to the enemy and the environment, developing a desired end state that represents mission accomplishment, and determining the sequence of activities that moves the task force from its current state to the end state. The commander begins to visualize the desired end state when he receives a mission or perceives a change in the mission. He applies his current situational understanding to the received or perceived mission. As he analyzes or receives staff analysis of the mission, he develops a mental image of the friendly forces in relation to the enemy, the environment, and possible future operations at the conclusion of the operation. The commander's visualization is his assessment tool throughout the operation. He should focus on three main factors.

(1) Situational understanding is derived from applying his judgment, experience, expertise, and intuition to the COP and allows the commander to understand the current state of friendly and enemy forces. Situational understanding includes physical factors, human factors, and the relationships between friendly and enemy forces and the environment that represent potential opportunities or threats for the task force.

(2) The commander must identify a feasible outcome to the operation that results in mission success and leaves the task force postured for the next operation.

(3) The commander must identify the dynamics of opposing forces throughout the sequence of actions. This includes evaluating possible enemy reactions and friendly counteractions. This evaluation may lead to the identification of possible critical decision points throughout the operation.

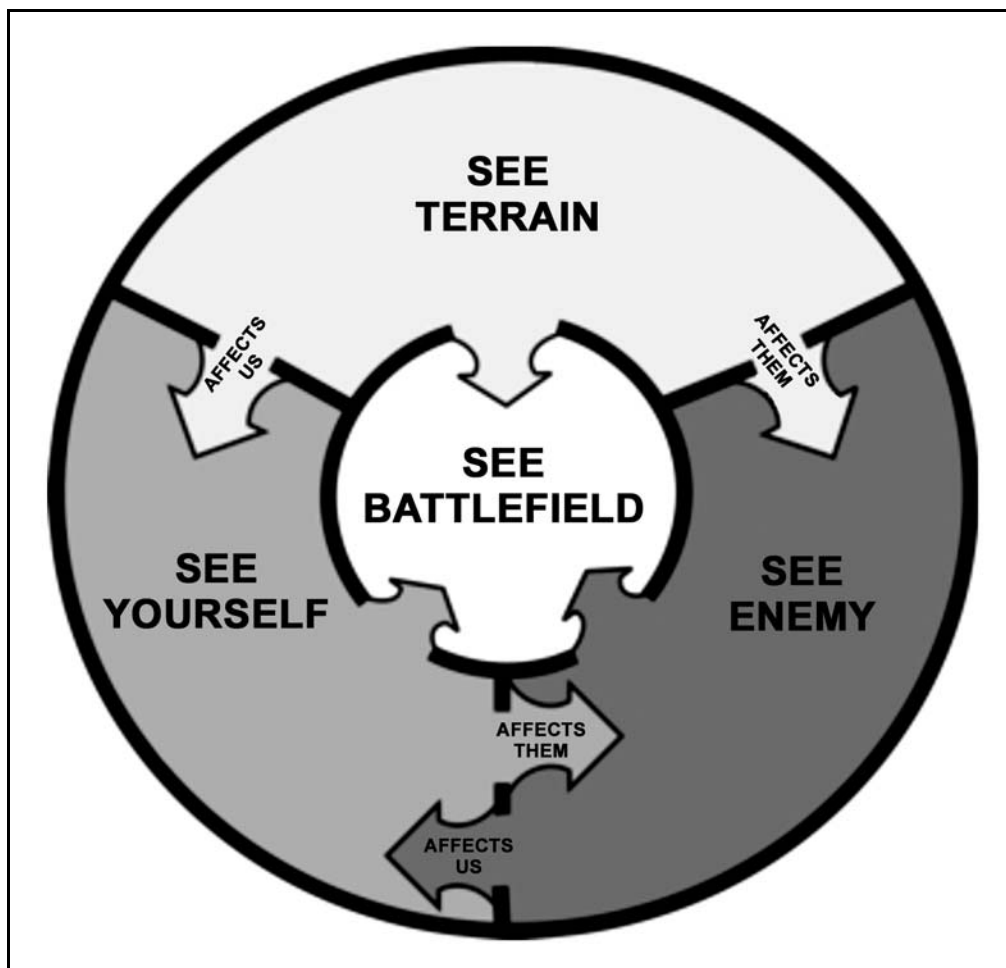


Figure 3-1. Visualization.

b. **Describe.** The commander describes his visualization continuously through the operations process. Specifically, his commander's intent, planning guidance, anticipated decision point(s), and commander's critical information requirements (CCIR) all serve to guide and focus the C2 system to support his decision-making and to communicate his decision for execution. INFOSYS are available to assist the commander in describing his visualization. However, he should not accept these products unquestioned. He must apply his judgment, experience, expertise, and intuition before making a decision and describing that decision to subordinates. During preparation, the commander uses the rehearsal to identify and discuss options at decision points, to synchronize activities within the TF and among subordinate units, and to add to his own visualization. The result may be further refinement of his intent and CCIR. During execution, the commander continues to visualize the implication of events, and he describes his conclusions to his staff and subordinates through updated CCIR and guidance.

c. **Direct.** The commander directs when he has made a decision and communicates that decision to his subordinates through an order.

(1) **Plan.** Orders should enable subordinates to understand their situation, their commander's mission and intent, and their own mission. The order (warning order [WARNO] or OPORD) should provide unity of effort in exercising disciplined initiative

by subordinate commanders. Clear direction is essential to mission success; however, commanders must strike a balance between *necessary but minimum direction* and *overly detailed direction*. The commander, or his staff, assigns graphical, written, or procedural control measures (permissive or restrictive) to prevent units from impeding one another and to impose necessary coordination. The commander should impose only the minimum control measures necessary to provide essential coordination and deconfliction among units.

(2) **Prepare.** The commander must update and validate his visualization during preparations as the results of ISR operations become available. He must determine whether new information (on enemy forces, friendly forces, or the environment) invalidates his plan, requires him to adjust the plan, or validates the plan with no further changes. The earlier the commander identifies the need for modifications the easier it is for him to incorporate and synchronize them into his plan. He describes the implications of his updated visualization on the plan and directs actions to effect his revisions through an order (WARNO, OPORD, or FRAGO).

(3) **Execute.** Execution includes a continuous process of assessing the current state of the operation and making adjustments to exploit opportunities and to account for unforeseen enemy actions. Combining the art of command and the science of control is most evident during execution. The commander exercises judgment and intuition continuously, assessing the situation and making decisions often with incomplete, conflicting, and vague information. Waiting for perfect information is rarely an option. During execution, the commander uses his visualization, continuously updated with a current COP, to ensure that his subordinate units execute appropriate measures for the actual situation. A major part of the "art of command" is to know when the plan must change and what criteria indicate a need for changes and then to determine what changes will maximize unit effectiveness. The commander directs these actions primarily through a FRAGO.

## Section II. COMMAND AND CONTROL

Command and control consists of two components: the commander and the command and control system. The commander uses the command and control system to exercise C2 over forces to accomplish a mission.

### 3-5. THE COMMAND AND CONTROL SYSTEM

The command and control system is the arrangement of personnel, information management, procedures, and equipment and facilities essential to the commander to plan, prepare for, execute, and assess operations.

a. **Personnel.** The command and control system in a task force begins with people. No amount of technology can reduce the importance of the human dimension since combat involves soldiers.

b. **Information Management.** Information management consists of information systems and relevant information (RI). INFOSYS provide an accuracy and reliability that can accelerate decision-making within the task force. INFOSYS also make mission execution efficient and effective, allowing the commanders and staffs to spend more time and energy on the art and human dimension of command and control.

c. **Procedures.** Procedures are standard and detailed sequences of activities within the task force to accomplish tasks. They govern actions within the command and control system to exercise command and control effectively and efficiently. Adhering to procedures minimizes confusion, misunderstanding, and hesitance as commanders rapidly shift forces to meet contingencies.

d. **Equipment and Facilities.** The equipment and facilities provide sustainment and a work environment for the other elements of the command and control systems.

### 3-6. DIGITIZATION AND THE C2 SYSTEM

The C2 system within a digitized task force is designed to collect, process, store, display, and disseminate the information needed to develop and refine a COP in support of a commander's mission. It supports a commander's exercise of command and control across the range of military operations.

a. The INFOSYS provide the commander and staff with the ability to plan, prepare, and execute using resilient voice and data communications networks to enable effective command and control on the battlefield. The TF integrates the INFOSYS through maneuver, fires and effects, logistics, force protection, information operations, and intelligence.

b. The INFOSYS within a digitized task force are organized to leverage fully the opportunities presented by near-real-time access to all RI and a near-complete COP. The INFOSYS provide all commanders within the task force with the capability to visualize and understand their area of operation in all its dimensions. It provides a shared COP of the situation, precisely locates and tracks friendly unit locations, highlights critical enemy locations, and synchronizes simultaneous operations with lethal and nonlethal means. This capability allows significantly enhanced synchronization of widely dispersed, highly mobile lethal forces in execution as well as in planning to mass effects.

### 3-7. EXERCISING COMMAND AND CONTROL

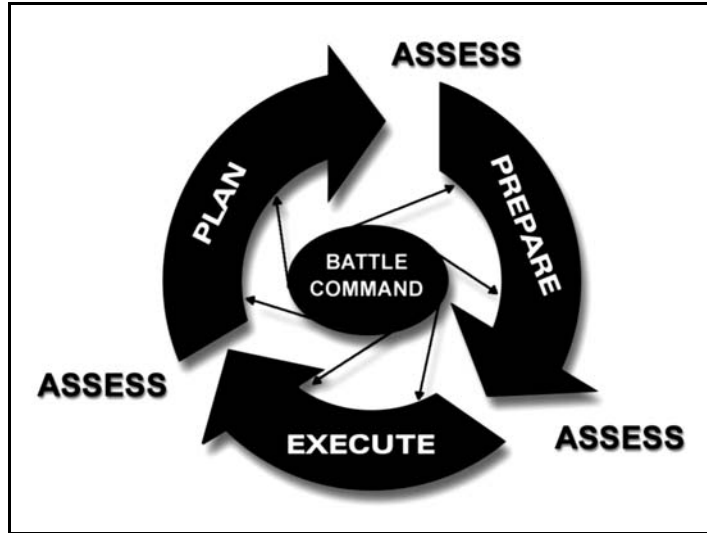
The task force commander must place the command and control system into action to exercise command and control. Exercising command and control is dynamic throughout the operations process.

a. Although planning, preparing, executing, and assessing occur continuously in operations, they need not occur sequentially. The task force must prepare to perform all four actions simultaneously, and the commander executing battle command is at the center of the process (Figure 3-2).

b. The operations process is execution-focused rather than planning-focused. INFOSYS compress planning to allow more time to focus on execution. The INFOSYS do this in two ways.

(1) The INFOSYS allow better parallel planning and collaboration among echelons within the task force.

(2) The INFOSYS provide a more accurate COP, allowing forces to execute faster with less detailed planning.



**Figure 3-2. The operations process.**

### **3-8. DISTRIBUTION OF TASK FORCE COMMAND AND CONTROL**

The TF's staff sections are normally distributed among four command and control organizations: the command group, main command post, combat trains command post, and rear command post (forward support company command post). The TF commander organizes the staff within each command post to perform essential staff functions to aid him with planning and in controlling operations. These command and control organizations are normally positioned within the TF's AO to maintain flexibility, redundancy, survivability, and mobility (see Chapter 11, Command Post Operations).

a. **Command Group.** The command group consists of the commander and whomever else he designates. This may include the fire support officer and air liaison officer. The purpose of the command group is the direct command and control of the task force. The command group is not a permanent organization; rather, it is formed anytime the commander goes forward to control an operation. The command group is equipped to operate wherever the commander feels it is necessary to influence operations with rapid decisions and orders. The commander determines the actual placement of personnel within the command group.

(1) The commander fights the battle from the command group and normally positions himself near the most critical event, usually with the main effort headquarters. From this forward location, the commander is better able to observe critical events, maintain communications, and sense the battle. The commander therefore leverages the INFOSYS to untether himself from the main CP so he can compare reality to his visualization of his subordinates and the terrain he is to fight on without affecting his decision-making ability.

(2) The commander considers the following in determining his location on the battlefield:

- Linkage of the INFOSYS (Army battle command system [ABCS] in digitized task forces) to make timely decisions, including the ability to judge the progress and condition of his forces. Within technical limitations, communications systems adapt to the needs of the commander, not vice versa.
- Time and location of critical events and decision points that have the greatest impact on mission accomplishment. Ideally, the commander selects a location where he can observe the conditions that aid in making a critical decision.
- Security for the command group, including the commander's personal protection.

b. **Main Command Post.** The main CP is the task force commander's principal command and control facility. The main CP moves as required to maintain control of the operation. In linear operations environments, it locates behind the company team CPs and, if possible, out of medium artillery range. In nonlinear operations (noncontiguous areas of operations), it locates where it can best support TF operations and where it is least vulnerable to potential hostile actions. The TF XO is responsible for supervising all staff activities and functions within the main CP. The main CP provides the following functions:

- Synchronizes combat, combat support, and combat service support activities in support of the overall operation.
- Provides a focal point for the development of intelligence.
- Supports situational understanding for the TF commander and subordinates by monitoring, analyzing, and disseminating information.
- Monitors and anticipates the commander's decision points.
- Plans future operations.
- Monitors sustaining operations.
- Coordinates with higher headquarters and adjacent units.
- Keeps higher headquarters informed.
- Serves as net control station for the operations and intelligence (OI) radio net and backup net control station for the command radio net.
- Provides terrain management.
- Provides a stable, secure planning facility.
- Produces and disseminates the commander's orders.
- Plans and controls ISR operations.

c. **Combat Trains Command Post.** The combat trains command post controls and coordinates the administrative and logistical support for the task force. The CTCP consists of the HHC commander and the TF S1 and S4. The unit maintenance collection point, battalion aid station, and forward support company forward cell will typically collocate with the CTCP. The TF S1 and S4 work closely with the FSC support operations officer to coordinate combat service support for the TF. The CTCP serves the following functions:

- Tracks the current battle.
- Controls sustainment operations.



- Provides combat service support representation to the main CP for planning and integration.
- Forecasts and coordinates future requirements.
- Monitors main supply routes (MSRs) and controls combat service support traffic.
- Coordinates the evacuation of casualties, equipment, and enemy prisoners of war.

d. **Forward Support Company Command Post (Field Trains Command Post in AOE Organizations).** The FSC CP controls the execution of resupply and maintenance support. It coordinates with the forward support medical company for medical evacuation operations for the task force. The FSC CP--

- Tracks the current battle.
- Provides CSS representation to the main CP for planning and integration.
- Forecasts and coordinates with the FSB for future requirements.
- Monitors main supply routes.
- Coordinates the evacuation of casualties, equipment, and enemy prisoners of war to the FSB.
- Coordinates the movement of the task force support area with the main CP.

### **Section III. PLANNING FOR OPERATIONS**

Planning for operations leads to a commander making decisions during execution. At its core, decision-making is knowing "if" to decide, then "when" and "what" to decide. It includes understanding the consequences of decisions. Decisions are the means by which the commander translates his vision of the end state into action. Decision-making is both science and art. Many aspects of military operations (movement rates, fuel consumption, and weapons effects) are quantifiable and, therefore, part of the *science* of war. Other aspects--the impact of leadership, complexity of operations, and uncertainty regarding enemy intentions--belong to the *art* of war. The military decision-making process is an established and proven analytical process. The MDMP adapts the Army's analytical approach to problem solving. It is a tool that assists the commander and staff in developing estimates and a plan. The digitization of the Army and its battlefield operating systems has not changed the steps of the MDMP; it has enhanced them. While the formal problem-solving process may start with the receipt of a mission and have as its goal the production of an order, the analytical aspect of the MDMP is continuous throughout operations (including execution) with constant feedback and updates of information.

#### **3-9. INFORMATION SYSTEMS ENHANCEMENT TO DECISION-MAKING**

The INFOSYS available in digitized organizations enhance both the science and the art of war in two primary ways.

a. **Enhanced Situational Understanding.** First, digital INFOSYS provide commanders and staffs with a better understanding of their area of operation. They help collect information more effectively; process it faster and more accurately; store it in a manner that provides instant access; display it in a more usable, tailored, and current format; and disseminate it to the right place faster, with fewer errors and less lag time, than analog information systems. The digital INFOSYS and information management make estimates more accurate, complete, and current than was possible with analog

information systems. Creating and maintaining a current, complete COP is essential to the MDMP and is the foundation for the commander's continuing visualization and all staff estimates.

b. **Enhanced Parallel Planning and Collaboration.** The second area in which these systems improve the MDMP is in parallel planning and collaboration. Parallel planning occurs when two echelons conduct their planning nearly simultaneously. Parallel planning can happen only when higher headquarters produces timely warning orders and shares information with subordinate headquarters as it becomes available. Parallel planning allows each echelon to make maximum use of time available. It requires significant interaction between echelons. Collaboration (paragraph 3-25, Coordination and Liaison) is the real-time interaction of commanders and staffs at two or more echelons. Collaboration is facilitated by digital INFOSYS that allow real-time exchange of data and voice so that commanders and staffs can work together during all aspects of planning. However, the digital INFOSYS cannot, and should not, replace a commander's face-to-face collaboration with his subordinates.

c. **Additional Information Processing Enhancements.** The digital INFOSYS improve the timelines to conduct full planning and will assist the commander with his understanding. (Figure 3-3 illustrates the cognitive hierarchy.) The commander and staff must process the information available to them.

(1) Processing raises the meaning of information from data to understanding. Data is organized and processed to create databases of information. Processing takes the data and adds meaning to the relevant information in the database using progressively higher levels of complex and cognitive methods to create an operational picture. The staff then takes the operational picture and refines it based on the commander's guidance. The product of this refinement is a common operational picture (COP).

(2) Processing also includes lower-level mechanical methods such as organizing, collating, plotting, and arranging data and information. However, effective processing requires analysis and evaluation (higher-level cognitive methods) for data to become knowledge. Through its estimates, the staff creates knowledge for the commander. The commander then applies his judgment to the staff estimates and the COP and formulates his understanding. Processing depends primarily on well-trained and adaptive analysts to provide insight. To achieve understanding, decision-makers apply judgment to the knowledge and the staff estimates. Understanding enables informed decisions with less-than-perfect data. Understanding generates action; with understanding and a mission, a commander can better visualize his area of operation and take action by issuing his commanders' intent and guidance and determining his CCIR.

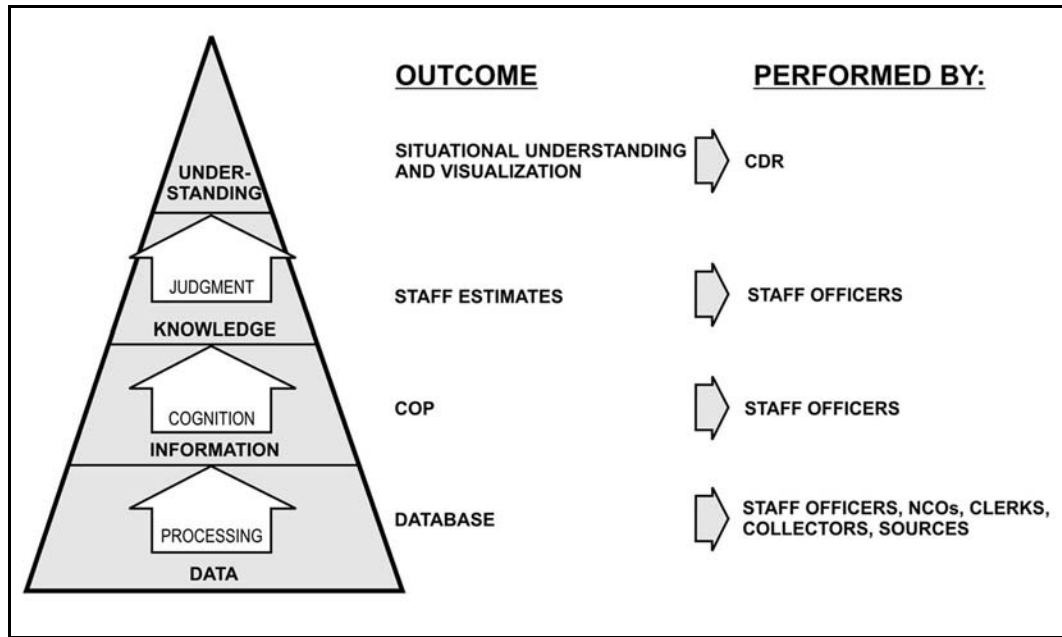


Figure 3-3. Cognitive hierarchy.

**3-10. THE MILITARY DECISION-MAKING PROCESS**

The MDMP is an established and proven analytical process; however, it is a detailed, deliberate, and sequential process optimally used when adequate planning time and sufficient staff support are available to develop and thoroughly examine numerous friendly and enemy courses of action. The commander and staff typically conduct this examination when developing the commander's visualization and operation plans, when planning for an entirely new mission, and during extended operations. The underlying concurrent processes of intelligence preparation of the battlefield, risk assessment (see Appendix D, Risk Management and Fratricide Avoidance and Appendix E, Environmental Concerns), targeting, force protection, and military deception planning provide the information that is used as part of the standardized planning in the MDMP. The MDMP helps the commander and staff to examine a specific situation and reach a logical decision by applying thoroughness, clarity, sound judgment, logic, and professional knowledge. The MDMP is the foundation on which planning in a time-constrained environment is based. The products created during the MDMP can and should be used during subsequent planning sessions when time may not be available for a thorough reexamination but when significant parts of existing information and analysis of METT-TC factors have not changed substantially.

a. The MDMP relies on doctrine, especially the terms and symbols (graphics) consolidated in FM 101-5-1. The professional understanding of a defined common lexicon particular to the profession of arms and the Army is essential to the MDMP. Using approved terms and symbols facilitates the rapid and consistent assessment of the situation and the creation and implementation of plans and orders by minimizing confusion over the meanings of terms and symbols used in the process.

b. The following are advantages of using the unabbreviated MDMP:

- It analyzes and compares multiple friendly and enemy COAs in an attempt to identify the best possible friendly COA.
  - It produces the greatest coordination and synchronization and minimizes the risk of overlooking a critical aspect of the operation.
  - It results in a detailed operation order or operation plan.
- c. The disadvantage of using the unabbreviated MDMP is that it is a time-consuming process.

### **3-11. ROLES OF THE COMMANDER AND EXECUTIVE OFFICER**

The commander is in charge of the military decision-making process. He decides what procedures within the MDMP to use in each situation, including whether or not to use collaborative planning. The commander's intent is the driving force behind the MDMP, which hinges on a clear articulation of the commander's visualization. The INFOSYS provide the commander with an unprecedented level and quality of information that help focus his attention on the critical elements of the situation and enable him to understand better the environment in which he is operating.

a. The commander is personally responsible for planning, preparing, and executing operations. From start to finish, the commander's personal role is central. His participation in the process provides focus and guidance to the staff; however, there are responsibilities and decisions that are the commander's alone. The amount of his direct involvement is driven by the time available, his personal preferences, and the experience and accessibility of the staff. The less time available and the less experienced the staff the greater the commander's involvement. When the commander is linked with his staff by the INFOSYS, he is more accessible and has more tools to provide guidance and to stay involved in the process regardless of his location within the area of operations.

b. During the MDMP, the commander uses the entire staff to explore the full range of probable and likely enemy and friendly courses of action and to analyze and compare his own organization's capabilities with those of the enemy. This staff effort has one objective: to integrate information collectively with sound doctrine and technical competence, which assists the commander in his decisions and ultimately leads to effective execution. Through the use of INFOSYS, the commander guides not only the staff but also subordinate commanders. He also uses the INFOSYS to access additional data from national or higher echelons to help in analyzing both the environment in which he is operating and the enemy.

c. The executive officer manages, coordinates, and disciplines the staff's work and provides quality control. He must understand the commander's guidance and intent because he supervises the entire process. The XO ensures the staff has the information, guidance from the commander, and facilities that it needs. He determines timelines for the staff, establishes briefback times and locations, enforces the information management plan, and provides any unique instructions to guide the staff in completing the MDMP process.

d. Warning orders are used to facilitate parallel planning. By issuing guidance and participating in formal and informal briefings, the commander and XO guide the staff through the decision-making process. In a collaborative environment, the commander can extend this participation directly to subordinate commanders and staffs. Such interaction helps the staff and subordinates to resolve questions and involves all staff and

subordinates in the complete process. The selected course of action and its implementing operation order are directly linked to how well both the commander and the staff accomplish each step of the MDMP.

### **3-12. THE ROLE OF INTELLIGENCE, SURVEILLANCE AND RECONNAISSANCE (ISR)**

The task force commander deploys the ISR assets (primarily the scout platoon) early in the planning process to facilitate early intelligence collection. However, the scout platoon should not be deployed without first considering, as a minimum, the doctrinal ISR concepts found in Chapter 4.

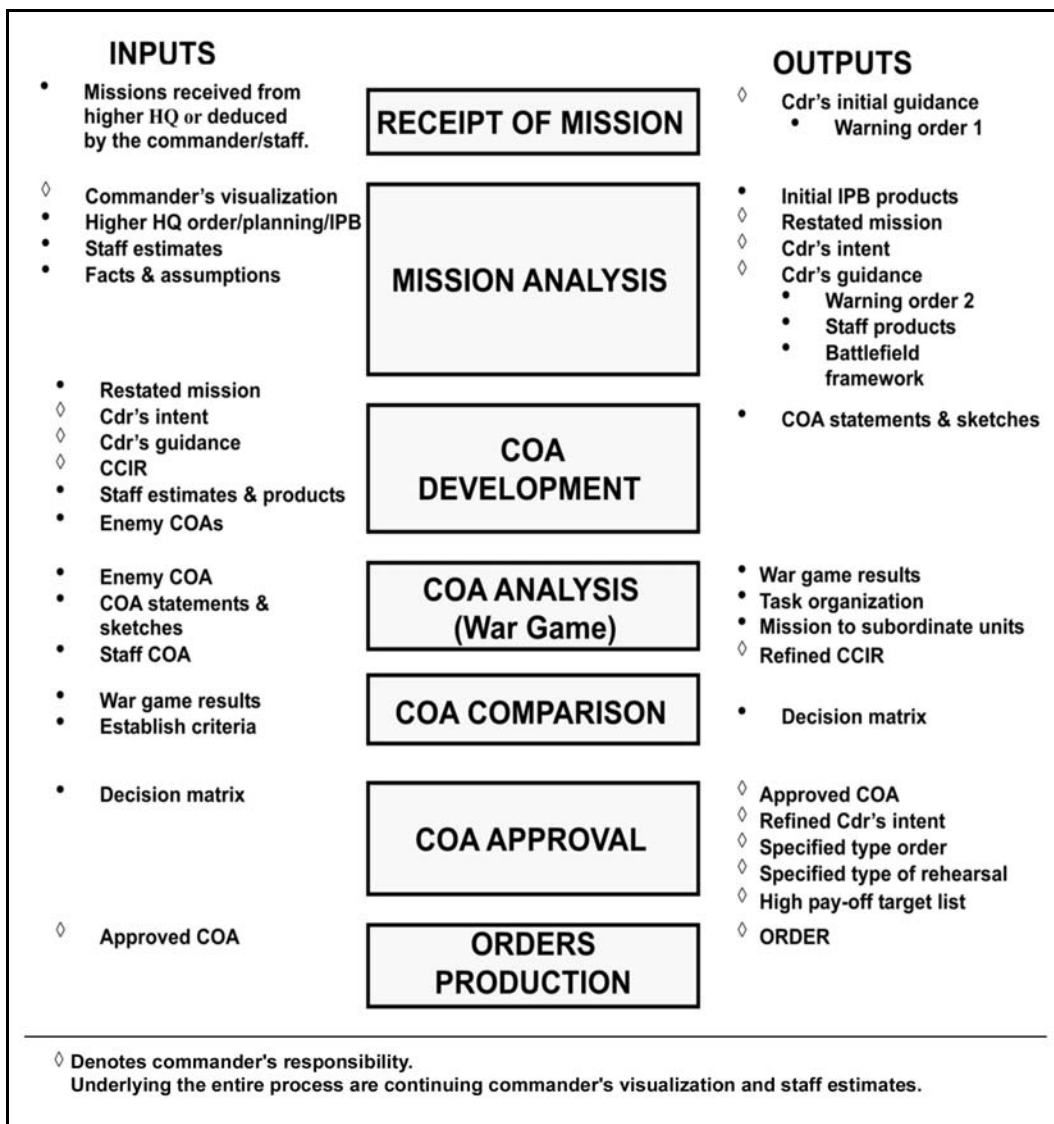
a. The commander and staff analyze the information collected from the scout platoon and other ISR assets and incorporate this information into the planning process. The commander and staff ensure ISR operations are continuous during planning, preparation, and execution of the mission. Information collected during ISR operations may result in initial plans or courses of action being modified or even discarded. The earlier the need for modifications can be identified, the easier it is to incorporate and synchronize the modifications into the plan. Further, when the situation changes, the commander must modify his ISR objective accordingly.

b. ISR assists significantly in developing courses of action. Conducted early in the planning process, it can help confirm or deny the commander's initial assessment (visualization). Information may also allow him to focus immediately on a specific course of action or to eliminate courses of action that reconnaissance shows to be infeasible.

c. When conducting ISR operations, the commander must determine if the benefits outweigh the risks. During defensive, stability, and support operations, the ISR operations can often be conducted with little risk. During offensive operations, ISR operations involve substantial risk.

## **Section IV. THE MILITARY DECISION-MAKING PROCESS**

The MDMP is a single, established, and proven analytical process. The complete MDMP is described in FM 101-5. It is a seven-step process that is summarized in this section. Each step of the MDMP builds upon the outputs from previous steps, and each step, in turn, produces its own output that drives subsequent steps (Figure 3-4, page 3-14). Errors committed early in the process affect later steps. Each staff section does estimates and estimates go on continuously to provide important inputs to the MDMP. Estimates and database updates support the planning process as well as mission execution.



**Figure 3-4. MDMP steps, inputs, and outputs.**

### 3-13. RECEIPT OF MISSION

The staff receives a new mission from higher headquarters, or the commander recognizes an opportunity that requires a significant change to the current operation. The staff begins to collect the data and resources necessary to conduct mission analysis. The XO develops the timeline to structure the staff's efforts, and the task force commander issues initial guidance to his staff that focuses them on developing initial CCIR, authorized movement, level of detail required in the MDMP, and initial reconnaissance requirements. The result of this step is a WARNO that alerts subordinate units to an impending mission change.

### 3-14. MISSION ANALYSIS

Mission analysis defines the tactical problem and begins the process of determining feasible solutions. Analysis of the higher headquarters' mission is the start point that generates the IPB. It then analyzes the specified, implied, and essential tasks laid out in the higher headquarters' order. It reviews the available assets, identifies critical facts and

assumptions, and evaluates risk. The results of mission analysis are the initial CCIR, an ISR plan, the task force's mission, the task force commander's initial intent for the operation, and the task force commander's guidance for the staff on developing COAs. These products are distributed to subordinates in the form of WARNO #2 to include orders to initiate reconnaissance operations

### **3-15. COURSE OF ACTION DEVELOPMENT**

The staff develops COAs for analysis and comparison. This begins with analyzing relative combat power and generating maneuver options. The staff arrays initial forces to accomplish critical tactical tasks and develops the scheme of maneuver that synchronizes the tasks using the battlefield framework. The final result is a COA statement and sketch that clearly portrays how the task force will accomplish the mission, and explains the scheme of maneuver. The COA statement and sketch serves as the basis for the COA analysis war game.

### **3-16. COURSE OF ACTION ANALYSIS (WAR GAME)**

The staff develops a set of standards used to evaluate each COA. The standards may be based on the principles of war, commander's guidance, doctrinal principles for the operation being conducted, or whatever measure is deemed important by the commander. The staff conducts a war game of each COA using an action, reaction, and counteraction methodology. This process allows them to view the likely outcome of the battle, allocate resources, synchronize BOS, and develop control measures. The results of each war game are assessed using evaluation criteria established by the commander and recorded for comparison against other COAs.

### **3-17. COURSE OF ACTION COMPARISON**

The staff evaluates each course of action and compares it against the others to determine which one best accomplishes the mission without undue risk. Each COA is briefed to the commander, and the staff makes its recommendation on the most preferred option.

### **3-18. COURSE OF ACTION APPROVAL**

The task force commander selects a COA, modifies it as required to better meet his intent, or rejects them all and has the staff develop new ones. The commander then finalizes his intent and CCIR based on the chosen COA. He gives guidance to the staff on the type of order to produce, rehearsals to conduct, and priorities for CS and CSS assets. The staff issues WARNO #3 reflecting these changes.

### **3-19. ORDERS PRODUCTION**

The staff finalizes the plan based on the commander's approval guidance and prepares to publish a written order, brief an oral order, transmit a digital order, or a combination thereof. The order includes graphical overlays and staff annexes as appropriate.

### **3-20. DECISION-MAKING IN A TIME-CONSTRAINED ENVIRONMENT**

The MDMP is the foundation on which planning in a time-constrained environment is based. The products created during the MDMP can and should be used during subsequent planning sessions when time may not be available for a thorough re-examination but

when significant parts of existing information and analysis of the factors of METT-TC have not changed substantially. The focus of any planning process should be to develop quickly a flexible, tactically sound, fully integrated, and fully synchronized plan that increases the likelihood of mission success with the fewest possible casualties. However, any operation may go beyond the initial plan. The most detailed staff estimates cannot anticipate every possible branch or sequel, enemy action, unexpected opportunity, or change in mission directed from higher headquarters. Fleeting opportunities or unexpected enemy actions may require a quick decision to implement a new or modified plan. The commander decides how to abbreviate the MDMP. What follows are suggested techniques and procedures that will save time. They are not exhaustive nor the only ways to save time, but they have proven useful. These techniques are not necessarily sequential in nature nor are all of them useful in all situations. What works for a unit depends on its proficiency and the factors of METT-TC in a given situation. The commander can use these, or techniques of his own choosing, to abbreviate the process.

a. **Training for the MDMP.** Before a unit can conduct decision-making in a time-constrained environment, it must master all of the steps in the MDMP. A unit can only shorten the MDMP if it fully understands the role of each and every step of the process and the requirements to produce the necessary products. Training on these steps must be thorough and result in a series of staff battle drills that can be tailored to the time available. Training on the MDMP must be stressful and replicate realistic conditions and timelines. Although the task is difficult, all staffs must be able to produce a simple, flexible, tactically sound plan in a time-constrained environment. Any METT-TC factor, but especially limited time, may make it difficult to follow the entire MDMP. An inflexible process used in all situations will not work. The MDMP is a sound and proven process that can be modified with slightly different techniques to be effective when time is limited. There is still only one process, however, and omitting steps of the MDMP is not the solution. Anticipation, organization, and prior preparation are the keys to success in a time-constrained environment.

b. **General Considerations.** The MDMP is abbreviated when there is too little time for a thorough and comprehensive application of the process. The most significant factor to consider is time. It is the only nonrenewable--and often the most critical--resource.

(1) There are four primary techniques to save time.

(a) The first is to increase the task force commander's involvement, allowing him to make decisions during the process without waiting for detailed briefings after each step.

(b) The second technique is for the commander to become more prescriptive in his guidance by limiting options. This saves the staff time by focusing members on those things the commander feels are most important.

(c) The third technique, and the one that saves the most time, is for the commander to limit the number of courses of action developed and war-gamed. He can also direct only one course of action for the staff to refine if he has personally and mentally conducted the MDMP to come up with his acceptable course of action.

(d) The fourth technique is maximizing parallel planning. Although parallel planning is the norm during the MDMP, maximizing its use in a time-constrained environment is critical.

(2) In a time-constrained environment, the importance of warning orders increases as available time decreases. A verbal warning order now, followed by a written order later



(or posted to a database), is worth more than a written order one hour from now. The same warning orders used in the MDMP should be issued when abbreviating the process. In addition to warning orders, units must share all available information with subordinates, especially IPB products, as early as possible. The digital INFOSYS greatly increase this sharing of information and the commander's visualization through collaboration with his subordinates.

(3) While the steps used in a time-constrained environment are the same, many of them may be done mentally by the task force commander or with less staff involvement than during the MDMP. The products developed when the process is abbreviated may be the same as those developed for the MDMP; however, they may be much less detailed and some may be omitted altogether. Unit SOPs tailor this process to the commander's preference for orders in this environment.

(4) When developing the plan, the staff may initially use the MDMP and develop branches and sequels. During execution, they may abbreviate the process. A unit may use the complete process to develop the plan while a subordinate headquarters abbreviates the process.

(a) *Advantages of Abbreviating the MDMP.* The advantages of using the abbreviated MDMP include the following:

- It maximizes the use of available time.
- It allows subordinates more planning and preparation time.
- It focuses staff efforts on the commander's specific and directive guidance.
- It facilitates adaptation to a rapidly changing situation.
- It compensates for an inexperienced staff.

(b) *Disadvantages of Abbreviating the MDMP.* The disadvantages of using the abbreviated MDMP include the following:

- It is much more directive and limits staff flexibility and initiative.
- It does not explore all available options when developing friendly courses of action.
- It may result in only an oral OPORD or FRAGO.
- It increases the risk of overlooking a key factor or failing to uncover a significantly better option.
- It may decrease the coordination and synchronization of the plan.

(c) *Benefits of Saving Time on MDMP Steps.* The benefits of saving time on the MDMP steps include the following:

- It refines more thoroughly the commander's plan.
- It conducts a more deliberate and detailed war gaming session.
- It considers in detail potential branches and sequels.
- It focuses more on actually rehearsing and preparing the plan.

c. **The Commander's Role.** The task force commander decides what adjustments to make to the MDMP, giving specific guidance to the staff to focus the process and save time. If the commander has access to only a small portion of the staff or none at all, he will need to rely even more on his own expertise, intuition, creativity, and understanding of the environment and the art and science of warfare. He may have to decide on his course of action, mentally war-game the outcome, and confirm his decision to the staff all in a relatively short time. If so, his decision will be based more on his experience than on a formal integrated staff process. The commander may elect to have the staff spend most

of its time developing, refining, and war-gaming his course of action rather than developing multiple courses of action.

(1) The commander should avoid changes to his guidance unless a significantly changed situation dictates major revisions. Frequent minor changes to the guidance can result in lost time as the staff makes constant minor adjustments to the plan.

(2) The commander may consult with subordinate commanders before making a decision. Subordinate commanders are closer to the fight and can more accurately portray the enemy's situation and that of their own unit. Additionally, consulting with subordinates gives them insight into the upcoming operation and allows them to maximize parallel planning. Using the digital INFOSYS (primarily FBCB2) greatly enhances this concept of maximizing parallel planning between the task force and the subordinate units.

(3) In situations where the task force commander must decide quickly, he should contact his higher headquarters and advise them of his selected course of action, if time is available, because it may affect the branches and sequels that his superiors are planning. However, the commander should not sacrifice exploiting an opportunity if he cannot contact higher headquarters.

d. **The Staff's Role.** The importance of staff estimates increases as time decreases. Decision-making in a time-constrained environment almost always takes place after a unit has entered the area of operations and has begun to execute operations. This means that the IPB, an updated COP, and some portion of the staff estimates should already exist. Detailed planning before operations provides the basis for information that the commander will need to make decisions as operations continue. Staff members must keep their estimates up-to-date so that when planning time is limited, they can provide accurate assessments quickly and move directly into course of action development. When time is short, the commander and staff use as much of the previously analyzed information and products from earlier decisions as possible. Although some of these products may change significantly, many (such as the IPB that is continuously updated) remain the same or require little change.

(1) The staff must use every opportunity to maximize parallel planning with the unit's higher headquarters. Maximizing parallel planning can save significant time but if not carefully managed it can also waste time. As a general rule, the staff must never get ahead of the higher headquarters in the planning process. The majority of the planning time should be spent developing the foundation of the plan, such as mission analysis. The staff should not develop and analyze courses of action without specific guidance and approval from higher headquarters.

(2) Collaborative planning may be used to further speed up decision-making. Collaborative planning facilitates subordinate parallel planning and takes advantage of the subordinates' intimate knowledge of their area of operations and associated threats and opportunities. Collaborative planning among staffs is plausible; however, there will often be tension between taking a commander away from an ongoing fight and the need to involve him in collaborative planning. Only the task force commander can determine which takes precedence and require a subordinate commander to participate in a collaborative planning session. The higher commander may direct that headquarters and a task force headquarters collaborate.

e. **Receipt of Mission.** This part of the process does not change in a time-constrained environment. However, the commander decides at this step whether or not to abbreviate the MDMP and, if so, specifies how he wants to do it.

f. **Mission Analysis.** The commander's direct involvement is essential to saving time during mission analysis. He must personally supervise and manage the mission analysis. If time is not available to conduct a detailed mission analysis, the commander, staff, and subordinate commanders (if collaborative tools are available) perform a rapid mission analysis. In extreme circumstances, mission analysis may be a mental process conducted by the commander and key staff. This should be the exception rather than the norm.

(1) The IPB process requires constant attention. Many delays during mission analysis can be traced to poorly conducted IPB. The S2 must quickly update the IPB based on the new mission and changed situation. This is critical to focus ISR assets, especially the scout platoon, and other ISR assets early to collect information that confirms adjustments to the initial plan. Event templates must be as complete as possible prior to the mission analysis briefing. Because event templates are the basis for war gaming, they must be constantly updated as new information becomes available.

(2) Staff officers conduct as formal a mission analysis briefing as time allows. However, they may be forced to brief their estimates orally, covering only information that has changed from the last staff estimate while placing the remainder of the information on a shared database. When severely time-constrained, they brief only critical information that directly affects the new mission. If the commander has been directly involved in the mission analysis, he may decide to skip the mission analysis briefing completely.

g. **Commander's Guidance.** One way to save time is in the issuance of the commander's guidance. The elements of the commander's guidance may be the same as the MDMP, but the guidance is much more detailed and directive. The commander can provide detailed information outlining what he expects in each course of action developed, including tentative task organization, decision points, and scheme of maneuver. He may also determine which enemy courses of action he wants to war-game as well as the branches or sequels he wants incorporated in each course of action. Detailed guidance keeps the staff focused by establishing parameters within which to work. Commander's guidance must be constantly reviewed and analyzed. As the situation changes and information becomes available, the commander may need to update or alter his guidance. This type of detailed guidance limits the staff's flexibility and initiative to save time, but it allows the staff more time to synchronize the course of action during the war gaming session. Once the guidance is issued, the staff immediately sends a WARNO to subordinate units. Alternatively, if subordinate commanders and staffs are part of a collaborative process, they get this updated guidance during the collaborative session. However, the staff must still capture this guidance and publish it in a WARNO.

h. **Course of Action Development.** A significant amount of time is gained by increased commander involvement in course of action development, resulting in detailed and directive commander's guidance. The greatest savings in time for the MDMP comes from the commander directing the staff to develop only a few courses of action (or a single course of action) instead of many.

(1) The task force commander and selected staff (to include selected subordinate commanders and staffs, if collaborative tools are available) save additional time by conducting a hasty war game once the courses of action are developed. The hasty war game allows the commander to determine if he favors one or more courses of action out of several proposed. It develops and matures one or more courses of action prior to the detailed war gaming session. If the commander cannot be present during the hasty war gaming session, then the staff conducts a course of action backbrief to the commander after the hasty war game. From the hasty war gaming session, the commander can make an early decision, allowing him to refine his course of action and make any necessary adjustments prior to the detailed war game. In extreme situations, this may be the only opportunity to conduct the war game process.

(2) The hasty war game can also be used to select a single course of action for further development. A commander's early decision to go with a single course of action allows his staff and subordinates to focus on the selected course of action instead of on multiple courses of action. It also allows the staff to concentrate on synchronizing the course of action rather than on continuing to develop it during the detailed war gaming session.

(3) When time is severely limited, the quickest process comes from the commander personally deciding to immediately begin developing one COA with branch plans against the enemy's most probable course of action. This decision is often intuitive and relies on the commander's experience and judgment to render a quick decision. The commander determines which staff officers are critical to assist him in this process, depending on the type of operation being planned. The minimum is normally the XO, S3, S2, and fire support coordinator. The commander may also include subordinate commanders, if available, either in person or through collaborative tools. This team must quickly develop a flexible course of action that it believes will accomplish the mission. In this case, the commander mentally war-games one or more courses of action, selecting the first one that appears to solve the problem for the staff to refine.

(4) Limiting the number of courses of action developed carries with it the risk of overlooking a significantly better course of action. Developing only one course of action is a risky approach. It provides the staff with little flexibility to apply its creativity and to explore options.

i. **Course of Action Analysis.** The commander and staff must war-game the courses of action to ensure all elements are fully integrated and synchronized. An early decision to limit the number of courses of action to be war-gamed, or to develop only one course of action, saves the greatest amount of time in this process. When war-gaming the courses of action, it is best to do so against all feasible enemy courses of action. However, the commander can save additional time by having the staff war-game against a smaller number of enemy courses of action. At a minimum, the actions at the decisive point must be war-gamed against the enemy's most probable course of action.

(1) The commander's direct involvement saves significant time in this step by allowing the staff to focus on only the most essential aspects of the war game. The commander can supervise the war gaming session and be prepared to make decisions, provide guidance, delete unsatisfactory concepts, and assist in keeping the staff focused. If the commander is present during the war gaming of multiple courses of action, he may identify the course of action he favors. He can then discard unwanted courses of action, allocating more time to refine the one selected.

(2) The commander must always assess risk. By limiting the number of courses of action, he has increased risk to the command. He must evaluate the course of action to ensure it will not render the force incapable of anticipated operations or lower the unit's combat effectiveness beyond acceptable levels.

(3) The staff should use the box technique, focusing first on the decisive action such as actions at the objective or the engagement area. If time permits, the staff war-games other critical events or boxes as well. The commander and staff must identify and prioritize the critical events they want analyzed. Analyzing essential tasks can identify these critical events.

(4) Staff officers save time if they specifically define and limit the evaluation criteria before they begin the war gaming session. The commander can greatly increase effectiveness here by specifying the most critical factors and their weighting to his selected course of action. Significant factors can be quantified, if possible, and limited to the four or five most important based on the mission statement, commander's intent, and commander's guidance.

(5) The staff works to support the commander's plan. However, as the staff refines the plan, it cannot become so biased that it develops a plan that is infeasible and unsupported. If the staff determines that it cannot support the commander's plan, a new course of action must be developed.

(6) The use of recorders is particularly important. Recorders should be trained to capture coordinating instructions, subunit tasks and purposes, and information required to synchronize the operation during the war gaming session. If this occurs, a portion of the order is written before the planning process is complete. The digital INFOSYS greatly simplify this process as information can be entered in preformatted forms in shared databases that represent either briefing charts or actual appendices to orders. Each staff section should have formats available to facilitate a networked production of orders.

(7) The location used for the war gaming session must be prepared and configured by the time the staff is ready to conduct the war gaming session. Charts and boards must be clean and ready for use. The blown-up terrain sketch and enemy situation templates must be prepared and present for the war gaming session. If equipped with digital INFOSYS, automated briefing products must be updated, digital terrain maps for the area of operations loaded in the appropriate INFOSYS, and automated tools (if available) for war gaming must have correct data entered.

(8) When only one course of action is developed, the purpose of the course of action analysis is to verify, refine, synchronize, and integrate the commander's course of action and recommend modifications as necessary. However, the analysis should follow the detailed war gaming process as much as possible to assist the commander in visualizing the outcome and identifying potential branches and sequels. As time allows, the staff can further war-game and develop these branches and sequels.

(9) In a severely time-constrained environment, and if automated tools are available, units may combine the war gaming process with the rehearsal in a virtual environment, including both the commander and staff and subordinate commanders and staffs. A significant benefit to this technique is that it allows the subordinate commanders to control their units during the war gaming process.

j. **Course of Action Comparison.** If the commander decides to war-game only one course of action, or if he chooses one during the war gaming session, no course of action

comparison is needed. If multiple courses of action have been war-gamed and the commander has not made a decision, the staff must conduct the course of action comparison. Limiting the evaluation criteria and weighting factors are the only significant shortcuts in this step.

k. **Course of Action Approval.** If the commander has observed and participated in the planning process, the decision may be rapidly apparent and the commander can make it on the spot. If the commander has not participated in the process to this point or has not made a decision, a decision briefing is required. Good course of action comparison charts and sketches assist the commander in visualizing and distinguishing between courses of action. The staff must ensure the courses of action meet the course of action criterion, *complete*. Time can also be saved by limiting the course of action briefing to only the decisive action or selected critical points. If only one course of action was developed, no decision is required unless the developed course of action becomes unsuitable, infeasible, or unacceptable. If this occurs, another course of action must be developed.

l. **Orders Production.** In a time-constrained environment, time is important and a verbal FRAGO may be issued first versus a written order. However, the staff must capture all the information in any verbal orders and warning orders and deliver a written order to follow up on any previously issued orders. If digitally equipped, the staff sends the FRAGO over the appropriate digital INFOSYS (most likely FBCB2). Once the decision is made that a verbal order is not issued, the staff immediately sends out a WARNO.

## **Section V. PREPARING FOR OPERATIONS**

Preparing for operations includes activities conducted by the task force before executing to improve its ability to conduct an operation. At a minimum, these activities include: plan refinement, rehearsals, ISR operations, coordination, inspections, and movement. Preparation occurs any time the task force is not executing. Ideally, preparation begins with the receipt of an order (as does planning) and ends as execution begins. Assessment during preparation monitors the progress of readiness to conduct. The commander evaluates preparations against his criteria for success to determine variances and to forecast the significance of those variances for mission accomplishment.

### **3-21. INTELLIGENCE, SURVEILLANCE, AND RECONNAISSANCE OPERATIONS**

During preparation, the task force commander answers some of his CCIR and improves his intelligence about the enemy and terrain through his available ISR assets (most likely the scout platoon). An ISR operation is planned and executed with the same level of importance as any operation. ISR operations are not static, one-time efforts that achieve a single goal and then end. As the scout platoon (or other available ISR assets) gathers information (answering the CCIR), the staff should modify the collection plan to account for new information requirements or modified CCIR and to redirect efforts to collect additional information. The commander and staff must continuously review IPB products against the current situation; they redirect the scout platoon or other ISR assets to focus on the most important unknowns remaining, emphasizing the current CCIR. The task force commander must balance his need for information with the ability of the scout platoon to gather it, the risk to the scout platoon during collection, the ability to sustain

the scout platoon over time and distance, the requirement to have the scout platoon available at critical times and places to support the decisive action, and the availability (time, type, and quantity) of other ISR assets.

### **3-22. SECURITY**

Security during preparation prevents surprise and reduces uncertainty through local security and operational security (OPSEC). Local security and OPSEC prevent the enemy from discovering the task force plan and protect the force from unforeseen enemy actions. The goal in conducting security operations is to prevent the enemy from gathering essential elements of friendly information (EEFI). Security is a dynamic effort that anticipates and prevents enemy intelligence-gathering efforts.

### **3-23. FORCE PROTECTION**

Force protection includes a combination of active and passive measures to deter, defeat, or mitigate enemy actions. It is not a discrete mission assigned to a single subordinate unit but a continuous effort executed by the task force and all of its subordinate units regardless of their mission, location, or threat. The commander and staff develop and initiate actions during planning but conduct the actions during preparation and execution.

### **3-24. PLAN REVISION AND REFINEMENT**

The task force commander adjusts plans based on new information. The enemy is also acting while the task force is preparing for an upcoming operation. As assumptions prove true or false, as the scout platoon (or other ISR assets) confirms or denies enemy actions and dispositions, and as the status of subordinate units change, the task force commander determines whether the new information invalidates the plan, requires him to adjust the plan, or validates his plan.

### **3-25. COORDINATION AND LIAISON**

During preparation, the task force conducts necessary coordination with higher, lower, adjacent, and supporting units. Coordination includes the establishment of all communication links to guarantee continuous contact during execution and may include sending and receiving liaison teams. This is especially critical when the task force is a subordinate element of an organization that lacks the same INFOSYS (digital or analog) and when units who lack the same INFOSYS are subordinated to the task force. Coordination is essential for synchronization during execution.

a. **Coordination.** Exchanging information is critical to successful coordination. Coordination may be both internal and external. Internal coordination occurs within the task force staff. External coordination involves subordinate and supporting units or staffs and higher headquarters. Coordination has four objectives.

(1) It ensures an understanding of the commander's intent and an understanding of subordinate and supporting unit roles.

(2) It ensures that all affected and interested personnel have been consulted or informed so they may respond as desired or adjust their plans and actions.

(3) It avoids conflict and duplication of effort among subordinate units, reducing the risk of fratricide and the expenditure of resources.

(4) It ensures that the commander and staff consider all relevant factors and effectively employ all available assets.

b. **Liaison.** Liaison provides a means of direct communications between headquarters. Liaison may begin with planning and continue throughout preparation and execution.

### **3-26. REHEARSALS**

The intent of a rehearsal is to practice actions to improve performance during execution. The extent of rehearsals depends on the time available. Rehearsals allow participants to become familiar with the plan and to translate the plan into a visual impression that orients them to the environment and other units when executing. Rehearsals imprint a mental picture of the sequence of key actions within the upcoming operation. Rehearsals also provide a forum for coordination among subordinate and supporting leaders. Rehearsals emphasize times, locations, and solutions for coordinating actions to achieve synchronization at critical points during execution. The battalion's leadership rehearses the plan against a wide range of likely enemy COAs that cause the task force to execute various maneuver options at different times and locations. The goal is to exercise the battalion's C2 system and subordinate commanders against potential situations that may arise during execution and force decision-making under the anticipated conditions of the battle. This promotes flexibility and agility while reinforcing the commander's intent. The commander seeks to rehearse the operation from initiation to occupation of the final objective or limit of advance (LOA). Often, due to time constraints, the commander prioritizes the maneuver options and enemy COAs to be rehearsed based on the time available. The focus of the rehearsal is locating the enemy, developing the situation, executing a maneuver option, and exploiting success. The rehearsal must consider the potential of encountering stationary or moving enemy forces.

## **Section VI. EXECUTION**

Execution is putting a plan into action by applying combat power to accomplish the mission using situational understanding to assess progress and make decisions. Inherent in the dynamic nature of execution is deciding to execute planned actions as well as deciding to adjust the plan based on changes in the situation. Combining the art of command and the science of control is most evident during execution. The commander exercises judgment and intuition continuously, assessing the situation and making decisions, often with incomplete, conflicting, and vague information. During execution, the commander uses his visualization, continuously updated with a current COP, to assess the progress of operations. His CCIR, continuously updated during the operation, guides updates to his situational understanding. Decision-making during execution follows the Assess, Decide, and Direct model with the MDMP at its core.

### **3-27. THE COMMAND AND CONTROL SYSTEM DURING EXECUTION**

During execution, the C2 system (paragraph 3-5) must continuously manage relevant information. It must compare the COP against the commander's intent, identify variances from the plan, and recommend ways for the commander to correct or exploit the variances. Finally, the C2 system must direct actions to counter unforeseen enemy or friendly actions and to exploit opportunities.



### 3-28. ADAPTING TO CHANGES

There are two methods for the task force to adapt to changes. The first method begins during planning and consists of anticipating changes and developing branches and sequels to the plan to deal with them. Anticipating changes does not end with planning; it continues throughout preparation and execution. The second method of adapting to changes is improvising, taking action, or adopting solutions to unforeseen changes during the operation. While improvisation is not the preferred method, situations frequently arise requiring its use. The real difference between the two methods is time. Anticipation occurs when enemy actions are foreseen early enough to develop an analytical response. Improvisation occurs when the enemy action is unexpected and does not allow time for the formal planning of a response.

### 3-29. ASSESSMENT

Assessing an operation during execution is an essential and continuous task. It is a deliberate comparison of previously templated outcomes to actual events, using the commander's criteria for success to judge operational success at any point during the operation. The commander and staff assess the probable outcomes of the ongoing operation to determine whether changes are required to accomplish the mission, to react to unforeseen threats, or to take advantage of unforeseen opportunities. The commander uses situational understanding to assess the ongoing operation to determine if the current plan is (or is not) still valid.

a. **Monitoring the Operation.** The commander and staff monitor the ongoing operation to determine if it is progressing satisfactorily according to the current plan (including any FRAGO that may have modified it). The staff monitors the various facts and assumptions that were the basis of the plan to ensure these remain valid or to see a need for new facts and assumptions that might affect current and future operations. Monitoring uses RI to develop a clear understanding of the current state of the task force in relation to the enemy and the environment. The staff processes this RI and presents it to the commander as a clear operational picture.

b. **Evaluating the Criteria for Success.** The commander and staff continue to evaluate the commander's criteria for success during execution. The staff must continually update their staff estimates and their sources of assessment to supplement and support the commander's visualization. Assessing success results in one of two outcomes.

(1) The operation is progressing satisfactorily and observed variances between expectations and the current situation are minor or within acceptable levels. Progress meets the commander's intent, and the concept of operations is still relevant to the situation. The result is that the operation continues as planned and leads to decisions foreseen by the plan.

(2) The operation as a whole is not proceeding according to expectations. The observed variances endanger the success of the operation. This assessment can result from unforeseen enemy successes or friendly failures, and it also can result if performance of critical indicators is much better than expected, presenting a significant opportunity to the task force. The commander makes a decision to eliminate the threat or to take advantage of the unforeseen opportunity.

### 3-30. DECISIONS

The task force commander should be ready to modify his plan if it is necessary to save the force, to accomplish the mission, or to achieve greater success. Adhering to a plan when the situation has changed can waste resources and opportunities. The flexibility to adapt to changing situations is the hallmark of a good commander. The task force must train to take advantage of unforeseen opportunities and to leverage the available INFOSYS to disseminate decisions quickly. The commander makes two basic types of decisions during execution: execution decisions and adjustment decisions.

a. **Execution Decisions.** Execution decisions implement anticipated actions and are directed by the order. The most basic form of this type of decision is applying combat power or conducting activities as outlined within the plan or within the commander's intent. Executing branches and sequels are execution decisions (Figure 3-5, page 3-30).

(1) **Critical Routine Functions.** The task force must accomplish routine tasks during execution. Although these tasks occur routinely, the commander must consciously consider them during execution. Failure to consider these routine tasks can waste resources, squander opportunities, or lead to mission failure.

(a) *Conduct Continuous ISR Operations.* ISR is a continuous process, feeding the commander's situational understanding and his decision-making. The task force commander should never keep the scout platoon and other ISR assets in reserve. During execution, these assets should be focused on answering the CCIR and looking for opportunities for the task force to exploit.

(b) *Adjust IR and CCIR Based on the Situation.* The commander and staff must continue to review the CCIR during execution. The staff continues to analyze IR against the mission and updated commander's intent to identify those indicators that may directly affect the commander's decision-making. As CCIR are answered or the situation changes, the commander must develop new CCIR. The staff must disseminate these new CCIR to subordinate and supporting units. The staff must develop a new collection plan and allocate assets (scout platoon or other ISR assets) to answer the new CCIR.

(c) *Track the Battle.* Battle tracking is monitoring designated elements of the COP that are tied to the commander's criteria for success. Battle tracking requires special attention from all staff officers. The XO and S3 must continue to monitor the progress of movement and recommend changes as required.

(d) *Refine the Targeting Process.* The commander's decisions provide the basis for targeting decisions made in support of the continuing operation. The commander remains alert to situations when he must give or modify targeting guidance to the staff. His guidance synchronizes the targeting process to continue achieving effects (lethal and or nonlethal) on the enemy.

(e) *Manage the Movement and Positioning of CS and CSS Units.* Massing the effects of combat power at a decisive point requires not only the maneuver of combat forces but also the movement of CS and CSS forces. CS and CSS forces must not interfere with the movement of combat forces to the decisive point. In the heat of executing a mission, it is easy to lose sight of the time required to reposition CS and CSS forces. The commander and staff must ensure that the movement of combat units does not outpace the movement of CS and CSS units. The commander's visualization should include the time required to move all task force assets to get to the right place at the right time.

(f) *Continue Terrain Management.* The task force must carefully track the location and land utilization of all units within the area of operations. Deconflicting land use among units in the task force area of operations is difficult but necessary during execution. The staff must ensure that adequate space, including the use of routes, is available at the right time to support critical activities. The commander's visualization should determine what space is required for what force at what time to support the decisive action.

(2) *Planned Actions.* The commander or staff must recognize that a particular event or action directed by the OPORD has met preconditions (events or triggers) for execution and direct the execution of this planned action. Modifying planned actions to fit the current situation is still considered a planned action. Branches and sequels to an order (or plan) are planned actions.

b. **Adjustment Decisions.** Adjustment decisions modify the plan to respond to unanticipated threats or opportunities. Typically, a commander's adjustment decision requires further synchronization across the BOS. The commander describes his visualization of the adjustment through additional guidance. He must pay particular attention to the effects of adjustment decisions on targeting and give sufficient guidance to support the targeting process. Adjustments take one of three forms: reallocation of resources, changing the concept, and changing the mission.

(1) *Reallocation of Resources.* The simplest adjustment is to reallocate resources. The commander can allocate additional combat support or reinforce a combat unit with additional combat forces. The commander should reinforce success if it creates the opportunity for more success.

(2) *Changing the Concept.* Changing the concept of the operation adjusts the way in which the operation is conducted without changing the mission. Most often, this modifies the decisive action to exploit an unforeseen opportunity or to counter an unexpected threat. An important adjustment decision is the commitment of the reserve. Employing the reserve successfully requires anticipation and visualization. These allow the commander to task-organize, position, and move the reserve force in a manner that minimizes any loss of momentum with their commitment.

(3) *Changing the Mission.* If the commander sees during execution that he cannot resolve a problem to accomplish his mission by reallocating resources or changing the concept, he may opt to change his mission. He should only do this as a last resort, and the change to the mission must still accomplish the higher commander's intent. Synchronizing the task force's new actions is the greatest problem this type of decision presents.

(4) *Adjustment Decision Methods.* When making adjustments to a unique or complex situation, the MDMP is preferred if time is available. When there is not sufficient time for the MDMP or during fast-paced combat operations, decision-making may become more intuitive for the commander. Intuitive (or recognition) decision-making emphasizes the commander's knowledge, judgment, experience, education, intellect, boldness, perception, and character.

(a) *Using the MDMP.* The commander may opt to use an abbreviated MDMP, focusing the staff on one course of action. This method also uses intuitive decision-making. It begins with the commander using his current situational understanding to visualize and mentally formulate a single course of action that solves the unforeseen

problem. He directs the staff to analyze and refine the COA. The commander resolves any inadequacies the staff detects through its analysis by revising or modifying the given course of action rather than developing a new one.

(b) *Recognition Decisions*. This type of decision-making requires the greatest involvement of the commander and the least involvement from the staff. It relies on the commander's experience in the use of intuitive decision-making to be successful. The commander visualizes the solution to a problem immediately, with little or no analysis of alternatives or outcomes. Recognition decisions do not necessarily follow the MDMP; however, the commander's decisions are well grounded in an understanding of the enemy and terrain, the updated commander's estimate and staff estimates, and the OPORD that began the operation (Figure 3-6, page 3-31). This approach focuses on situational understanding, assessing significant variances, and selecting or refining an acceptable decision mentally instead of comparing multiple options to select the optimal answer.

### 3-31. DIRECTING ACTION

Any decision to change a plan requires a change in the application of combat power and a resynchronization to mass effects on the enemy. The task force commander must direct action that applies combat power to effect execution or adjustment decisions. The FRAGO is the normal means to direct changes during execution. Digital INFOSYS give the C2 system the capability to automate orders (and graphics) production and dissemination, especially for execution.

a. **Synchronize Operations**. After the task force commander makes a decision during execution, his staff must resynchronize the ongoing operation to maximize the application of combat power against the enemy. This resynchronization includes informing subordinates, integrating assets, incorporating the decision into the targeting process, and deconflicting subordinate actions. The staff can use digital INFOSYS to reduce duplication, confusion, and problems that may occur from the change. Resynchronization should be used only to the extent required to ensure mission accomplishment. Excessive synchronization may waste valuable resources and opportunities.

b. **Maintain Continuity**. Continuity (making as few changes as necessary) allows for a greater chance of successful execution. Continuity does not inhibit flexibility; the task force commander and his staff should only make the changes to current operations necessary to solve a problem. Maintaining the current plan as much as possible allows subordinates to focus on only a few discrete changes. The commander and staff should avoid changes that may preclude options for future operations.

### 3-32. TRAINING AND PERFORMANCE

The ability to accomplish unit tasks successfully lies in the training level of the soldiers and the leaders' mastery of the leader tasks. The entire unit, if equipped with digital INFOSYS, must learn new procedures to acquire the full advantage of digitization once they have mastered the analog methodology.

a. Digitization's largest impact is on the commanders and leaders in the practice of command and control. Integrating this new digitized equipment into the operations process poses a challenging problem for future commanders and leaders.

b. Executing battle drills or any other type of operation using new, digitized equipment and procedures at first seems more difficult and dangerous than existing methods. It is imperative that commanders, leaders, and soldiers understand both the advantages and the limiting factors of digitization and apply the advantages while overcoming the initial complicating difficulties. Adapting to digital INFOSYS will be a continuing process for commanders as new equipment and processes are tested, proven, and fielded to combat units.

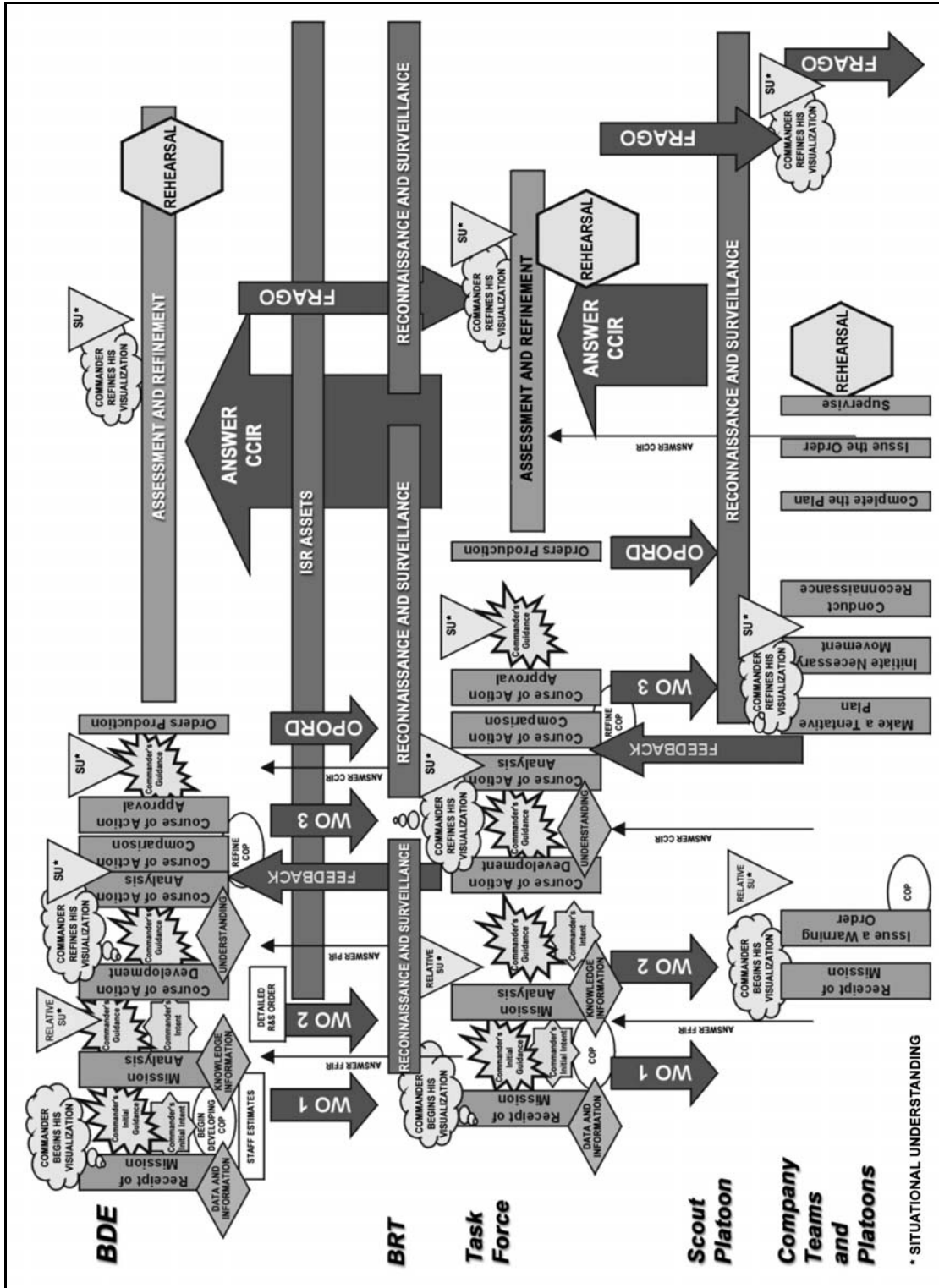


Figure 3-5. The steps in the MDMP.

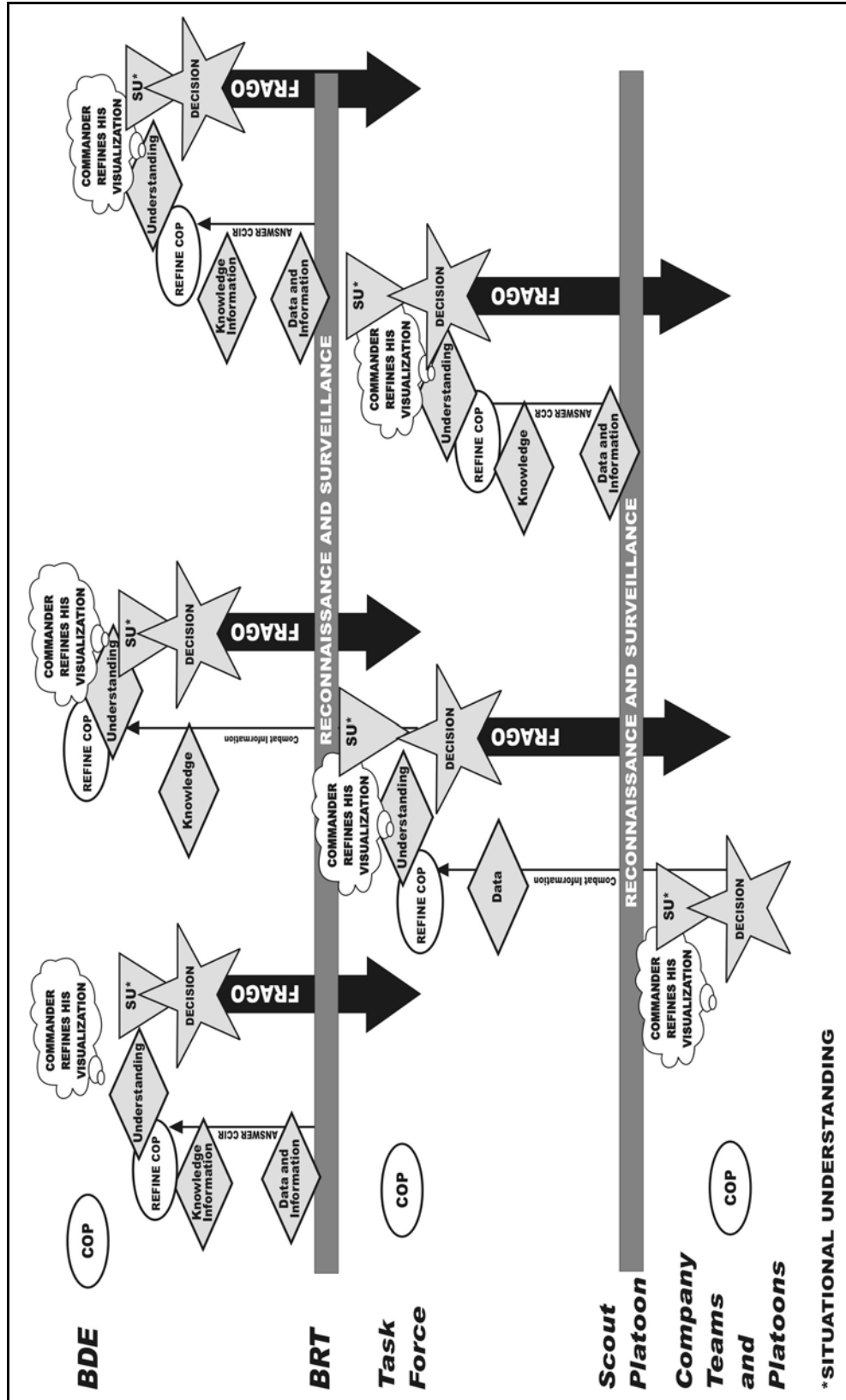


Figure 3-6. Executing an operation.

---

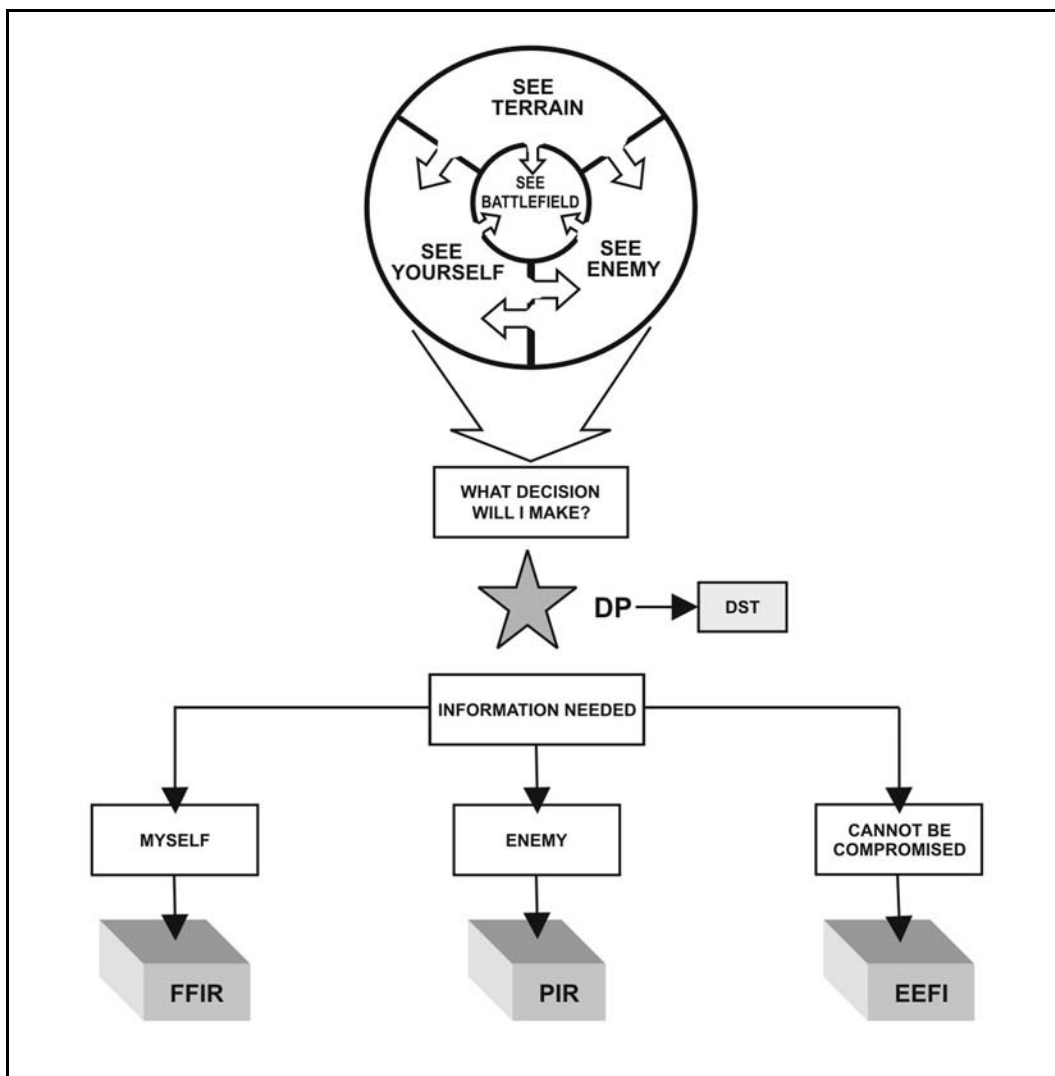
CHAPTER 4  
**INTELLIGENCE, SURVEILLANCE, AND  
RECONNAISSANCE OPERATIONS**

*All tank and mechanized infantry battalion task forces conduct ISR operations to produce intelligence on the enemy, environment (to include weather and terrain), and civil considerations necessary to assist the commander in developing situational understanding and making decisions. ISR operations require fully developed plans that begin during mission analysis. ISR operations are a commander's function supported by the entire staff and subordinate units. ISR develops, synchronizes, and integrates intelligence from a multitude of collection sources. These operations are multifaceted, and their integration eliminates unit and functional "stovepipes" for planning, reporting, and processing information and producing intelligence. ISR operations must be nested from division to battalion levels. Integration of division cavalry or reconnaissance assets with the TF and brigade assets ensures security and the ability to maintain the initiative.*

**Section I. FUNDAMENTALS OF INFORMATION COLLECTION  
MANAGEMENT**

The TF conducts ISR operations first to answer the CCIR (Figure 4-1, page 4-2) and second to facilitate targeting and fill voids in information. Timely and accurate intelligence encourages audacity and can facilitate actions that may negate enemy superiority in soldiers and materiel. Timely and accurate intelligence normally depends on aggressive and continuous ISR. To meet these needs, a fully developed ISR order is required. Understanding the fundamentals of collection management is key to the development of an effective ISR order. This chapter describes the fundamentals of information collection management and other collection assets, techniques for ISR planning, and tactics, techniques, and procedures (TTP) for ISR execution (see FM 3-90, Chapters 12 and 13).





**Figure 4-1. Commander's critical information requirements.**

#### 4-1. COLLECTION MANAGEMENT

Collection management is a cyclic process that seeks to define what information is required, determine the best method to collect the information, allocate assets to gather information, disseminate intelligence derived from that information to commanders and staff, assess the value of intelligence, and ultimately repeat the cycle. The result is a continuous feed of relevant information that facilitates the commander's situational understanding that ultimately allows him to make better decisions. The collection management process is shown in Figure 4-2, page 4-6. ISR is a continuous process that involves the entire staff. The TF S3 is the chief ISR integrator. He is assisted primarily by the S2 in concert with the remainder of the staff. The TF XO supervises synchronization of the ISR plan and its subsequent execution.

a. **Step 1: Develop Requirements.** The development of ISR requirements begins with the task force's receipt of brigade WARNOs and eventually the brigade OPORD. At this early stage in the operations process, the TF commander and staff begin to identify gaps in information. These gaps, or information requirements, are the beginning of what

will become the ISR plan. Some gaps in information may be answered through RFIs to higher headquarters. Other uncertainties about the enemy and terrain can be answered with the task force's organic ISR assets in order to continue planning and eventual execution. During mission analysis, the commander, assisted by the staff, develops initial PIR and IR. These information requirements will constitute the majority of the initial ISR plan and send out the scouts. It is from this initial ISR plan that all future requirements will be added.

(1) Mission analysis results in situation templates and an event template. This initial event template is primarily composed of named areas of interest (NAIs) that will focus only on identifying which of the predicted enemy courses of action (ECOAs) the enemy has adopted. Upon completion of the mission analysis brief, or as part of the brief, the commander approves the initial ISR plan and preliminary reconnaissance can begin. As the staff continues with the MDMP, the reconnaissance effort answers information requirements. This information assists the commander to validate or refine his visualization. Refinement or a change in visualization based on new information may generate new requirements for the ISR effort.

(2) Once COA analysis is complete, the event template is refined to support friendly decision-making, resulting in the decision support template (DST). This matured event template and DST graphically illustrate in time and space the NAIs and the target areas of interest (TAIs) that are linked to the commander's decision points (DPs). The NAIs, TAIs, and DPs expressed on the DST link the things the commander needs to know with the geographical location where the information may be found and the time the information is likely to be available. These new information requirements (approved CCIR, DPs, and their supporting architecture) constitute the remainder of the ISR plan and are sent to ISR assets either digitally or FM.

(3) Other sources of information requirements include specific orders and requests (SOR) for information from a higher headquarters; specific requests for intelligence or information may come from subordinate or adjacent units. These IR are also incorporated into the ISR plan, which should specify--

- WHAT (activity or indicator).
- WHERE (NAI or TAI).
- WHEN (time that the indicator is expected to occur and the latest time the information is of value [LTIOV]).
- WHY (justification--what decision is the PIR linked to).
- WHO (who needs the results).

(4) When all of the intelligence requirements and PIRs are gathered, they are sorted to reduce redundant requirements and prioritized to assist in allocating resources. The commander then re-evaluates each requirement and finalizes his CCIR.

(5) Ideally, each intelligence requirement will be sufficiently detailed and specific to allow collection. In many cases, the IR will have to be broken down into specific information requirements (SIR) sets that ask very specific questions about indicators. These indicators are tasked to collectors, and taken together they answer the larger question. For example: one of the TF commander's PIR is "*will the enemy regiment attack through AA2 with battalions abreast, or from the march? (Triggers repositioning of TF2 into BP1A).*" This is a broad question and many indicators could lead to its answer. SIR to support this PIR might include--

- Will enemy units of 3-5 combat vehicles enter NAIs 11, 12, and 13 between 130400MAR and 130700MAR?
- Will enemy battalion #2 move from its assembly area at NAI 7 prior to 130230MAR?
- Identification of second enemy battalion (over 40 BMP2s) in NAI 11, 12, or 13.

b. **Step 2: Develop the Collection Plan.** The development of the ISR plan follows the same construct as COA development of the maneuver plan; therefore, its development is a collaborative effort between the S3 and S2, supported by the remainder of the staff. It is based on the commander's information requirements and guidance for reconnaissance (see Paragraph 4-3) as well as the products produced in IPB. The TF XO supervises overall development and synchronization of the ISR plan. After identifying the SIR that will answer the PIR and intelligence requirements, the S3, in cooperation with the S2 and the entire staff, begins to develop the collection plan. The staff plans to task assigned or attached assets, requests support from higher headquarters, and recommends tasking to subordinate echelons.

(1) The planners begin to match requirements with specific collection assets based on the following factors.

(a) *Availability.* Determine what assets are organic and readily available. When will attachments arrive? What systems are not fully mission-capable and when will they be repaired? What are the maintenance and crew rest requirements? What systems are available in higher, adjacent, and subordinate units? How long will it take the asset to get into position?

(b) *Capability.* Determine if the asset can answer the questions asked? Does it have sufficient range? Can it operate in the expected climate and visibility conditions? Will it be necessary to maintain contact with the target when it is identified?

(c) *Vulnerability.* What is the threat's ability to locate, identify, and destroy the collector both at the target area and on the route to and from the mission? Is the risk of loss greater than the potential gain of information? Will the asset be needed for other subsequent operations?

(d) *Performance History.* How reliable is the specific asset based on training, leadership, and past experience. Who are the "work horses" that can get the job done?

(2) The staff develops the collection strategy taking into account the following concepts.

(a) *Cuing.* Cuing involves the use of one or more sensor systems to provide data that directs collection by other systems. For example, sweeping the battlefield electronically with a wide area surveillance system such as GSR reveals activity that triggers direct collection by a more accurate, pinpoint sensor system such as an unmanned aerial vehicle (UAV).

(b) *Redundancy.* Redundancy involves the application of several identical assets to cover the same target. Use redundant tasking against HPTs when the probability of success by any one system is low. For example, several scout teams infiltrate over different routes when the risk of detection is high but no other systems are capable of collecting the required information.

(c) *Mix.* Mix refers to planning for complementary coverage by a combination of assets from multiple disciplines. Sensor mix increases the probability of collection,

reduces the risk of successful enemy deception, facilitates cueing, and provides more complete reporting. For example, thermal imagery from a UAV may indicate several vehicle-like hot spots in a suspected enemy battle position (BP). A scout team observing the same NAI may reveal that half of those hot spots are actually decoys and not enemy armored vehicles.

(d) *Integration*. Integration is the resource management aspect of collection strategy development. Barring a decision to use redundant coverage of a critical target, attempt to integrate new requirements into planned or ongoing missions. Integration helps avoid the common problem of under-tasking very capable collectors. During limited periods of time, collection capability may exceed that of the taskings. The TF commander can resolve this by re-evaluating each of his collection assets for excess capability; focusing excess collection capability on the most important of the remaining unfulfilled requirements; and finally redirecting assets to maximize support to the most important requirements--new or old.

(3) Once an asset is chosen to collect information for an IR, planners turn the SIR into an SOR. The SOR is a directive statement that tailors the reporting criteria to the collection capabilities of the tasked asset. For example:

- An SIR may ask: “Is the enemy artillery battalion (over 12 2S1s) located in NAI 8 between 04800 and 052000MAR?”
- An SOR to a scout team might state: “Report the presence of 2S1 artillery systems in NAI 8 between 04800 and 052000MAR. LTIOV: 052200MAR.”
- An SOR to a signal intercept team might state: “Report presence of communications nodes linked to a fire direction net operating in NAI 8 between 04800 and 052000MAR. LTIOV: 052200MAR.”

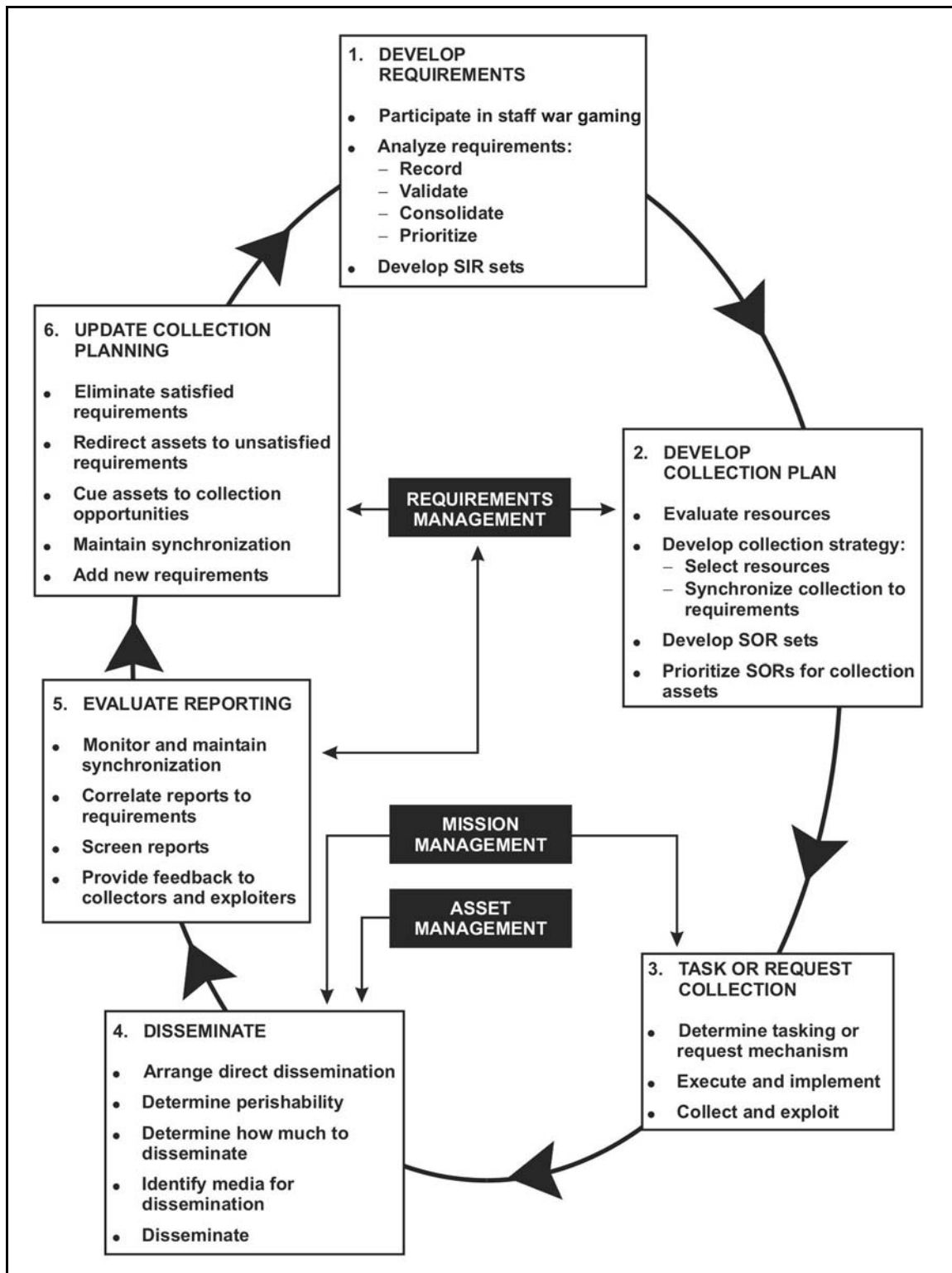
(4) SORs are prioritized for each specific asset. An SOR that is the number one priority for the UAV may be a lower priority for GSR.

(5) Once the staff has completed the ISR COA, it synchronizes the plan with the remainder of the BOS (see paragraph 4-6, ISR Order Development). This step is critical not only to ensure collection occurs at the right time and place but also to ensure it is supported appropriately. It is this step which sets the stage for successful ISR operations.

c. **Step 3: Task or Request Collection.** The primary means of tasking collection assets is the ISR order. The ISR order is published prior to the completed TF order or as part of WARNO #2 and WARNO #3 in order to start reconnaissance as soon as possible and answer the commander’s information requirements.

(1) *Task Collection*. The method used to task collection is time-dependant. In a time-constrained environment, tasking to the scout platoon and other ISR assets, as discussed in step 1, may be as simple as an ISR graphic and order matrix. When a more deliberate planning process occurs, it is preferable for ISR assets to be briefed by the TF staff in addition to receiving the ISR graphics and order. Upon completion of COA analysis and maturation of the ISR plan, FRAGOs are used to retask assets already conducting operations and to adjust ISR execution.

(2) *Request Collection*. The S2 sends SOR to higher headquarters in the form of an RFI and ensures that the status of those requests are tracked and answered to support the PIR. Additionally, the S2 utilizes intelligence reach operations to obtain information directly related to PIR and SIR from existing databases at adjacent units, higher echelons, and national level.



**Figure 4-2. Collection management cycle.**

d. **Step 4: Disseminate.** The ultimate goal of the dissemination process is to get the right information in the hands of the TF commander in time for him to make the decision.

Planners arrange direct dissemination from the collector to the requestor. Whenever possible, write into the SOR the requirement for direct dissemination of information to the requestor. For example, information regarding NAI 1 that triggers a targeting decision at TAI 1 (employment of the TF's allocation of CAS) should go to the TF commander as well as the FSO, ALO, and S2 to determine if it answers the CCIR and is what the TF commander wants to target. A well-synchronized ISR plan directs the collectors as to what nets to use to pass on information and to whom. The plan should detail when to use a net call, use of precedence coding (flash, priority, and so forth), and dissemination using digital systems. Perishability is a key consideration in dissemination. At the TF level most information generated during execution is *combat information* and requires immediate dissemination to the commander.

e. **Step 5: Evaluate Reporting.** As the operation progresses, the TF XO monitors as the S2 tracks the status of each SOR and begins to analyze SIR and ultimately PIR. They pay particular attention to which assets are not producing the required results. It is very likely that the staff's assumptions about the enemy COAs will not prove entirely correct. This may result in changes to the intelligence requirements or adjustments to the collection timeline. The XO, S2, and S3 assess the value of the information from collection assets and refine SORs to fill in gaps during execution.

f. **Step 6: Update Intelligence, Surveillance, Reconnaissance Planning.** As with all operations, the collection plan will rarely survive contact with the enemy and will require adjustment during execution. The following factors could drive changes to the collection plan:

- An SOR is satisfied or overcome by events, freeing an asset for other operations.
- A single asset has unexpected success, freeing redundant assets for other operations.
- An asset cues the collection manager but requires confirmation that requires dynamic retasking of other assets.
- The timing of the operation has become desynchronized, requiring modification of LTIOV or changes to prioritization.
- The commander generates new intelligence requirements as the COA evolves and the enemy situation develops.
- Higher headquarters FRAGOs the TF into an unplanned operation.

#### 4-2. TIERS OF RECONNAISSANCE

Tiers of reconnaissance are procedures that are used to better illustrate how ISR operations contribute to the commander's ability to see the battlefield and what types of information (CCIR and IR) are needed and when. Tiers of reconnaissance are based on offensive reconnaissance planning. (See Figure 4-3, page 4-8.)

a. **Tier 1.** Tier 1 reconnaissance occurs before the operation commences and primarily answers voids in information (IR). Tier 1 reconnaissance generally entails basic scout missions (route and zone reconnaissance) that facilitate the unit getting from the assembly areas (AAs) or attack positions to the objective.

b. **Tier 2.** Tier 2 reconnaissance occurs preferably before, but may also occur as, the main body begins execution. Tier 2 confirms the enemy's COA and validates the TF base plan of attack. Tier 2 answers CCIR (such as: *DP-Tiger Strike North* or *Tiger Strike*

*South*) but also answers IR (maneuver event-driven targeting) that support TF indirect fire planning.

c. **Tier 3.** Tier 3 is primarily surveillance and occurs during the operation. Tier 3 confirms the enemy's reaction to our base plan (his branches) and provides the commander the critical information (CCIR) he needs to make decisions (DPs). Tier 3 DPs are usually maneuver-based (such as *DP-Tiger Trap North*) or targeting-based (DP to commitment of FA or air assets to destroy an HVT).

d. **Tier 4.** Tier 4 reconnaissance occurs after the decisive operation. While Tier 3 is both reconnaissance (focused on future operations, generally answering IR) and surveillance (maintaining contact with the enemy), Tier 4 restarts the reconnaissance "cycle."

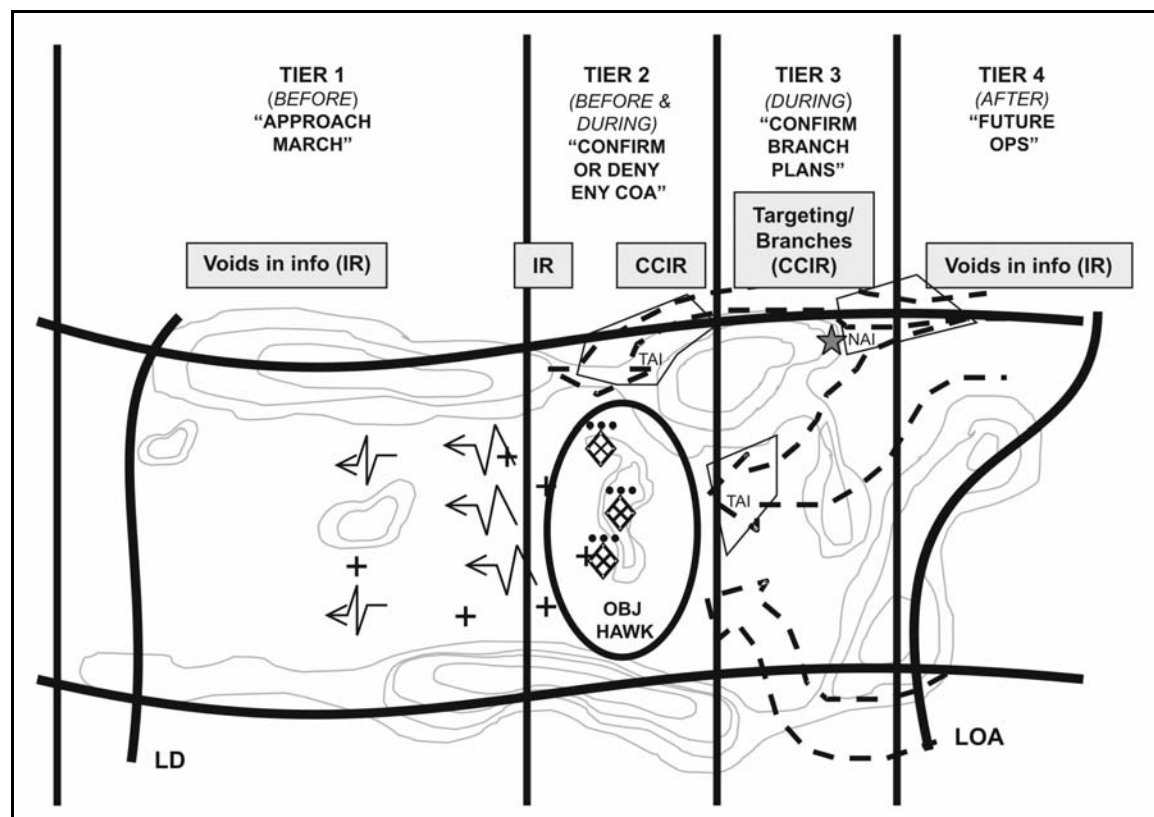


Figure 4-3. Tiers of reconnaissance.

#### 4-3. RECONNAISSANCE OPERATIONS

Reconnaissance is a mission designed to obtain information on the enemy or characteristics of a particular area. Reconnaissance is the precursor to all operations and may be accomplished through passive surveillance, technical means, human interaction, or by fighting for information. (See FM 17-95.) Successful reconnaissance operations are planned and performed with six reconnaissance fundamentals in mind.

a. **Orient on the Reconnaissance Objective.** The commander focuses the reconnaissance effort on the specific (critical) areas or objectives for which information is needed. The reconnaissance objectives are based on the PIR established by the

commander and serve to prevent wasted effort and time on areas that are not important to the planning and decision cycle.

b. **Maximize Reconnaissance Assets.** The TF must seek ways to include all of its subordinates into the reconnaissance and surveillance (R&S) effort and include those instructions and requirements in the OPLAN.

c. **Gain and Maintain Contact.** Contact with the enemy or reconnaissance objective is critical to collecting information. Once contact is established, the enemy or location is continuously monitored until information about it is no longer required. Contact must be maintained until the requirement is met or contact is handed over from one observer to the next. Close coordination is required in passing an enemy from one observer to another and eventually to the follow-on maneuver elements.

d. **Develop the Situation.** During reconnaissance operations, it is important to rapidly gain situational understanding to provide the commander with the information he needs to effectively maneuver the TF. Reconnaissance assets must be prepared to alter their plans and react to a changing battlefield environment in support of the commander's intent. This may require them to adjust execution as the situation becomes clearer.

e. **Report all Information Rapidly and Accurately.** Combat information is extremely time sensitive; information loses its relevance as it ages. The commander and staff develop a plan to employ the TF based on information requirements that must be fulfilled. Delayed, inaccurate, or misdirected information may lead to missed opportunities or poor decisions. The SIRs developed by the S2 help subordinates focus on the information required for decision making.

f. **Retain Freedom of Maneuver.** The ability to maneuver is essential to reconnaissance operations. Planners must anticipate tactical developments and constantly develop COAs that avoid decisive engagement of reconnaissance assets and preserve them for future operations. Reconnaissance assets that become engaged usually fail in their primary task, are unavailable for subsequent tasks, and often risk bringing on a larger engagement not envisioned by the commander.

#### 4-4. RECONNAISSANCE GUIDANCE

The commander must provide specific guidance to the reconnaissance force. The commander's guidance for reconnaissance includes focus, tempo, and engagement criteria. This guidance is an extension of the commander's intent and is designed to focus the reconnaissance commander's efforts in relationship to the TF mission.

a. **Focus.** Focus is the expression of what types of information the TF commander is most concerned with. The commander's focus for reconnaissance usually falls in three general areas: CCIR, targeting, and voids in information. The commander's focus allows reconnaissance to prioritize taskings and narrow their scope of operations. An operation may have a terrain focus where status of routes, bridges, and obstacles are more important than the enemy. Conversely, the operation may focus on the enemy where locating his security zone, main body, and reserves are essential. Additionally, commanders may express their focus in terms of reconnaissance pull and push.

(1) **Reconnaissance Pull.** Reconnaissance pull is used when the enemy situation is not well known and or the situation is rapidly changing. Reconnaissance pull fosters planning and decision-making based on changing assumptions into confirmed information. Initial assumptions and PIR are used to deploy reconnaissance assets early



to collect information for use in the development of COAs. The commander uses ISR assets to confirm or deny initial PIRs prior to the decision on a COA or maneuver option, thus pulling the TF to the decisive point on the battlefield. Success of the reconnaissance pull requires an integrated reconnaissance plan that can be executed prior to the commander having to make a COA decision.

(2) **Reconnaissance Push.** Reconnaissance push is used once the commander is committed to a COA or maneuver option. The commander pushes his ISR assets forward, as necessary, to gain greater visibility on specific NAIs to confirm or deny the assumptions on which the COA is based. Information gathered during reconnaissance push is used to finalize the TF plan.

b. **Tempo.** The commander establishes the time requirements he envisions for the reconnaissance force and expresses them in a statement that describes the degree of completeness, covertness, and potential for engagement he is willing to accept. The following describes the rate TF commanders use to control the momentum of reconnaissance operations.

(1) **Deliberate.** Operations are slow, detailed, and broad-based. They require the accomplishment of numerous tasks. This is a description of the degree of completeness required by the commander. Significant time must be allocated to conduct a deliberate reconnaissance.

(2) **Rapid.** Operations are fast paced, focused on key pieces of information, and entail a small number of tasks. This is a description of the degree of completeness required by the commander. It describes reconnaissance operations that must be performed in a time-constrained environment.

(3) **Stealthy.** Operations are conducted to minimize chance contact and prevent the reconnaissance force from being detected. They are often conducted dismounted and require increased allocation of time for success. This is a description of the level of covertness required by the commander.

(4) **Forceful.** Operations are conducted without significant concern about being observed. They are often conducted mounted or by combat units serving in a reconnaissance role. It is also appropriate in a stability or support operation where the threat is not significant in relationship to the requirement for information. This is a description of the level of covertness required by the commander.

(5) **Aggressive.** Operations have very permissive engagement criteria and allow the reconnaissance commander to engage in combat to meet his IRs. This is a description of the potential for engagement.

(6) **Discrete.** Operations have very restrictive engagement criteria and restrain the reconnaissance forces from initiating combat to gain information. This is a description of the potential for engagement.

c. **Engagement Criteria.** The commander establishes what enemy forces he expects reconnaissance forces to engage and with what level of force. This decision assists the reconnaissance leadership in planning direct and indirect fires and establishing bypass criteria. It is particularly important when the reconnaissance force is augmented with combat systems to conduct reconnaissance in force or security operations.

#### 4-5. FORMS OF RECONNAISSANCE

To logically group SIRs and tasking into missions for subordinate commanders, the TF commander uses one of four forms of reconnaissance. (See FM 17-95.) The forms of reconnaissance serve to further refine the scope of the reconnaissance commander's mission and give it a spatial relationship. The four forms of reconnaissance are route, area, zone, and reconnaissance in force.

a. **Route.** A route reconnaissance is an operation focused on obtaining detailed information on a specific route and all adjacent terrain from which the enemy could influence the route. The route may be a road or an axis of advance. Route reconnaissance is performed to ensure that the route is clear of obstacles and enemy, and that it will support planned movement. A route reconnaissance may be performed as part of an area or zone reconnaissance. The following are critical tasks associated with a route reconnaissance:

- Assess trafficability of the route.
- Locate enemy forces that can influence movement on the route.
- Identify lateral routes in the area of responsibility.
- Classify bridges.
- Identify overpasses, underpasses, and culverts that might restrict access.
- Clear or locate bypasses to any defiles.
- Locate mines, obstacles, or barriers.
- Locate bypasses around built up or contaminated areas.

b. **Area.** An area reconnaissance is a directed effort to obtain detailed information concerning the terrain or threat activity within a prescribed AI. The reconnaissance of the area can be conducted by maneuvering elements through the area or by establishing observation posts (OPs) within or external to the AI. See paragraph c below for critical tasks associated with an area reconnaissance.

c. **Zone.** A zone reconnaissance is a directed effort to obtain detailed information concerning all enemy forces, routes, obstacles, and terrain within a zone defined by boundaries. A zone reconnaissance is assigned when the situation is vague or when information about cross-country trafficability is desired. It is appropriate when previous knowledge of the terrain is limited or when combat operations have altered the terrain. The reconnaissance may be enemy-oriented or terrain-oriented. A zone reconnaissance is deliberate and time consuming. Critical tasks associated with both zone and area reconnaissance include the following:

- Determine location and strength of enemy forces.
- Reconnoiter terrain for its impact on the operation.
- Locate and determine the extent of contaminated areas.
- Locate bypasses to all natural or manmade obstacles.
- Classify all bridges, underpasses, overpasses, and culverts.
- Conduct route reconnaissance as required.

d. **Reconnaissance in Force.** A reconnaissance in force is a deliberate combat operation designed to discover or test the enemy's strength, dispositions, and reaction or to obtain other information. A commander uses a reconnaissance in force when the enemy is known to be operating within an area and the commander cannot obtain adequate intelligence by other means. A unit may also conduct a reconnaissance in force in restrictive terrain where the enemy is likely to ambush smaller reconnaissance forces.

A reconnaissance in force is an aggressive reconnaissance, conducted as an offensive operation in pursuit of clearly stated CCIR. The overall goal of a reconnaissance in force is to determine enemy weaknesses that can be exploited. It differs from other reconnaissance operations because it normally is conducted only to gain information about the enemy and not the terrain. The TF requires significant augmentation with combat elements to conduct a reconnaissance in force. Specific tasks include the following:

- Penetrate the enemy's security zone to determine its size and depth.
- Determine the location and disposition of enemy main positions.
- Attack the enemy main positions to cause the enemy to react with local reserves, counterattack forces, fire support assets, or specific weapon systems.
- Determine weaknesses in enemy dispositions that can be exploited.

#### **4-6. INTELLIGENCE, SURVEILLANCE, RECONNAISSANCE ORDER DEVELOPMENT**

Reconnaissance is the precursor to all operations. As such the development of the ISR order (Step #9 Mission Analysis--Determine the Initial ISR Plan) is one of the most critical steps in the battalion MDMP.

a. The TF's MDMP formally begins with the receipt of the brigade OPORD. However, brigade WARNO #1 and #2 may provide the staff with sufficient information to start IPB. Once the staff receives a finalized COA and specified tasks found in WARNO #3 and the brigade OPORD, it can begin the formal mission analysis. However, when parallel and collaborative planning is used, the commander and staff have already begun to identify initial PIR and IR early in the process. These information requirements are included in the commander's initial guidance to the staff for development of the ISR plan. The commander's initial guidance to the staff includes--

- How to abbreviate the MDMP
- Initial time allocation
- Initial ISR planning guidance to staff and or initial reconnaissance to begin (usually based on required movement).
- Authorized movement
- Additional tasks the commander wants the staff to do.

b. The commander's initial ISR planning guidance includes the commander's initial information requirements based on his analysis and his staff's initial assessment. These information requirements are primarily planning-focused. The staff's mission analysis will yield information requirements from the IPB process. The two basic IPB-generated information requirements are the result of terrain and enemy analysis.

(1) **Terrain Analysis.** The terrain analysis may generate uncertainties about the terrain that can affect how the battalion plans for the operation. These uncertainties might include--

- Does AA1 support tactical movement?
- Where along AA1 must the battalion conduct a defile drill?
- Can the battalion easily ford that creek in multiple places or is it restricted to ford sites and or bridges?

(2) **Enemy Analysis.** The TF commander and staff develop ECOAs and prioritize them in the order of probability; this, in turn, forms the basis for determining the IRs for

the ISR assets. Enemy COAs take the form of situation templates (SITEMPs). Differences between the situational templates form the initial event template. This initial event template focuses only on identifying which of the predicted COAs the enemy has adopted. (See FM 34-130.) The initial event template forms the base of the ISR graphics. Later in the process, the event template will be refined to support the commander's decision-making during execution--the DST. The development of the situation templates and the event template is not the sole responsibility of the S2 but rather is a collective staff task. The following are examples (not all-inclusive) of staff input to ECOA development, SITEMP, and event template development and reconnaissance objectives.

(a) *Air Defense--*

- Likely air corridors.
- Likely timing of air strikes or air assault operations.
- Likely targets and objectives of enemy air operations.
- How the enemy ADA is organized to protect its forces.
- Whether the enemy will use air in reconnaissance or counterreconnaissance role.

(b) *Fire Support--*

- Where are enemy target acquisition assets (such as radar)?
- Where will the enemy deploy his artillery?
- Determines high-value targets (HVT) (further develop into HPTs during the war gaming and targeting process).
- How deep can his indirect fires range?

(c) *Engineer--*

- Where will enemy emplace obstacles (protective, tactical, situational)?
- Time required to emplace each type of obstacle.
- Time required to breach obstacles.
- Time required to entrench a mechanized company.
- Ability to bridge different size rivers and streams and time required for each.

(d) *NBC--*

- Enemy capabilities to employ NBC weapons and obscurants.
- Types of delivery systems, including minimum and maximum ranges.
- Enemy NBC protection capabilities.
- Indicators of preparations to employ NBC weapons.
- Friendly assets the enemy is likely to consider HPTs for NBC targeting.
- Existing contaminated areas that may indicate the COA adopted by enemy.

(e) *Signal--*

- Ability to locate or intercept friendly systems.
- Speed that the enemy can collect, process, and target communication and C2 sites.
- Ability to link collection systems to indirect fires.
- Deployment patterns of signals intelligence (SIGINT) collection systems.
- Techniques of electronic deception or network attack.

(f) *Civil Affairs (CA)--*

- What is the political situation in the AO?
- What factions are friendly, neutral, or enemy?

- Where are areas that civilians gather to protest or demonstrate?
  - From whom or where is information gained on particular AOs?
- c. Once integration of the ISR plan is completed, it must be synchronized (scheme of support) with the BOS to ensure all provisions are made for its success. Synchronization considerations include:
- Location, mission, and specific instructions regarding brigade reconnaissance troop (BRT) or other higher ISR assets.
  - Specific instructions to TF maneuver assets (maneuver support, fire control measures, extraction considerations, for example).
  - Required ADA support (ADA warning network, A2C2 measures).
  - Required fire support (EFST considerations and coordination measures).
  - Required mobility/counter mobility/survivability support.
  - Required logistics support to include class III, V, medical, and maintenance.
  - Required communications support (long-range communications equipment, retrans, C2 locations, and compatibility, for example).
- d. During the mission analysis brief or shortly after, the commander approves the initial ISR plan. Following approval, reconnaissance can begin. In a time-constrained environment, dissemination of the order may be as simple as an overlay and matrix sent to the TF scout platoon and other participating assets via LNO or digital means. However, the preferred method of dissemination is for the staff to brief ISR assets in conjunction with order and graphic dissemination. This method is best because it also provides the TF commander the opportunity to personally convey his focus for reconnaissance to the scout platoon and other assets. The ISR plan will include--
- Brigade mission.
  - Brigade commander's intent.
  - Reconnaissance objectives for the TF.
  - CCIR.
  - Focus, tempo, and engagement criteria.
  - Specified reconnaissance tasks.
  - Fires plan.
  - CASEVAC plan.
  - Resupply plan.
  - Camouflage plan.
- e. Under normal circumstances, ISR assets receive the mature ISR plan through FRAGOs that adjust their requirements and execution based on the war game and DST. Additionally, the mature ISR plan is not only included but also integrated into the TF scheme of maneuver to ensure full synchronization between ISR and maneuver:
- The product of mission analysis is used to develop the ISR order.
  - The ISR order addresses all aspects of the reconnaissance operation to include insertion methods, supporting fires, casualty evacuation (CASEVAC) and CSS, and extraction contingencies.

- The commander's guidance for reconnaissance includes focus, tempo, and engagement criteria.
- The TF's initial counterreconnaissance plan is also part of the ISR order. Other essential products in the ISR order include the ISR graphical overlay, the enemy SITEMP, and the ISR tasking matrix.

#### **4-7. INTELLIGENCE, SURVEILLANCE, RECONNAISSANCE OVERLAY**

The ISR overlay expresses the ISR order in graphic form. If it is transmitted over digital systems, it may need to be broken into component parts to speed transmission and reduce clutter. For example, it could be broken into one overlay showing the basic operational graphics and boundaries, one overlay showing infiltration graphics, and one overlay showing sensor locations and range fans (see Figure 4-4, page 4-16). Regardless of its component parts, the ISR overlay should contain the following:

- Friendly boundaries and phase line (PL).
- NAIs/TAIs.
- LOAs and limits of reconnaissance (LORs).
- Counterreconnaissance AOs for all units.
- FSCM.
- Graphics depicting zone, area, or route reconnaissance.
- Routes, start points (SP), release points (RP), and checkpoints.
- Primary and alternate OP locations.
- Ambulance exchange points (AXP) and logistics release points (LRP).
- Planned or existing obstacles.
- Scan sectors for sensors.
- UAV flight paths.
- Retrans locations.

#### **4-8. ENEMY SITUATION TEMPLATE**

The S2 develops an enemy SITEMP for the ISR operation that focuses on the enemy's reconnaissance and counterreconnaissance efforts. It is designed to aid in planning friendly infiltration and survivability by identifying enemy actions that will impact on friendly reconnaissance efforts (see Figure 4-4, page 4-16). The enemy SITEMP should include--

- Locations of known and suspected enemy locations.
- Suspected enemy boundaries.
- Enemy avenues of approach for the main body with time phase lines (TPLs).
- Likely enemy reconnaissance and infiltration routes with TPLs.
- Likely enemy OPs and patrols.
- Enemy artillery range fans.
- Known and templated obstacles.

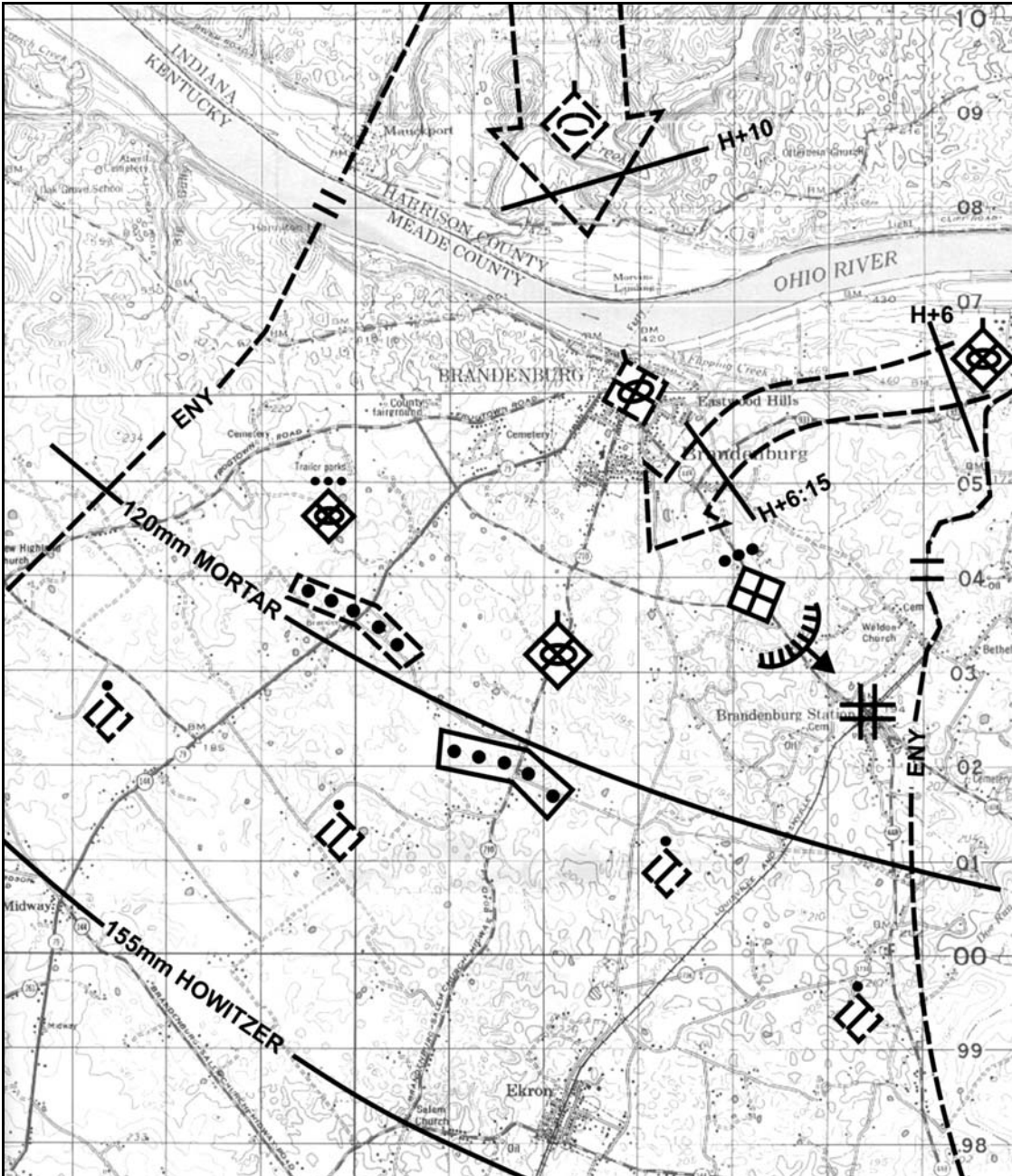


Figure 4-4. Situation template.

#### 4-9. TERRAIN MANAGEMENT

The TF distributes its reconnaissance assets throughout its AO. To prevent fratricide and to synchronize the collection effort and logistic support, the TF must organize the battlefield. When assigning boundaries and task-organizing subordinate units, the TF commander should include the terrain team or engineer leadership in the decision process.

## Section II. SECURITY OPERATIONS

The purposes of security operations are to provide early and accurate warning of enemy operations, to provide the protected force with time and maneuver space to react to the enemy, and to develop the situation to allow the commander to employ the protected force effectively. Units may conduct these operations to the front, flanks, or rear of a larger force. Security operations provide reaction time, maneuver space, and protection to the main body. Security operations are characterized by aggressive reconnaissance aimed at reducing terrain and enemy unknowns, gaining and maintaining contact with the enemy to ensure continuous information, and providing early and accurate reporting of information to the protected force. Security operations forces orient in any direction from a stationary or moving force. Security operations are designed to deny the enemy intelligence information concerning the TF. Security operations contain both passive and active elements and normally include combat action to seek, destroy, or repel enemy reconnaissance units. The TF performs three primary types of security missions: screen, guard, and area security. The TF normally participates in covering force operations only as part of a larger element.

### 4-10. SCREEN

The primary task of a screening force is to observe, identify, and report information. The screening force protects the main body, impedes and harasses the enemy with supporting indirect fires, and destroys enemy reconnaissance elements within its capability.

a. **TF Screen.** At the TF level, the scout platoon normally performs screen missions. When the terrain provides multiple enemy avenues of approach, the TF commander may attach the scout platoon to a company team to conduct a screen. The screening force generally establishes a series of OPs and conducts patrols to ensure adequate surveillance of the assigned sector.

b. **Company Team Screen.** A company team may be directed to conduct a screen in support of TF offensive and defensive operations. When given a forward screen mission, the company team moves as in a movement to contact.

c. **Planning a Screen.** When assigning a screen mission to a company team, the TF commander or operations officer designates the general trace of the screen and the time it must be established. The initial screen line should be forward of the general trace but remain within range of supporting artillery. Screen lines are depicted as phase lines; passage graphics are included in the overlay.

(1) Designate the left and right limits of the screen as well as a phase line for the rear boundary. This phase line can also become the on-order BHL.

(2) Confirm which unit has responsibility for the area between the screening force's rear boundary and the main battle area (MBA). This should be the company team that occupies the sectors behind the screen.

(3) Designate general locations for OPs that enable observation of the avenues of approach into the sector.

(4) Select routes or sectors to facilitate rearward displacement.

(5) Augment the security force as needed to provide intelligence, engineer, air defense, signal, and combat service support.

d. **Intelligence Support.** The S2 designates which NAI the company team must observe and when. The S2 does not dictate the location of company team elements or



how the company team maintains surveillance of the NAI. If GSRs operate under TF control to support the security effort, the S2 positions these assets and integrates their locations and missions with the security action of the screening company team. Once the screen force commander positions his unit, he informs the S2 of their primary, alternate, and subsequent locations.

e. **Maneuver.** Generally, the best unit configuration for the screen mission is a mechanized infantry company team. The ability to place infantry squads on the ground and conduct surveillance operations and active patrolling is an essential passive aspect of the screen mission. The tank platoon may be employed to destroy the enemy's reconnaissance vehicles during the counterreconnaissance fight.

f. **Fire Support.** The FSO prepares for the screen mission as he would for a defense in sector. He uses the enemy situation template as a guide to plan fires to interdict enemy maneuver elements. He plans protective fires for all screen force positions; this helps prevent screening force elements from becoming decisively engaged with the enemy. Accurate indirect fire is essential to the destruction of the enemy reconnaissance effort. The FSO conducts a time-distance analysis covering the enemy's probable rate of advance and the time of flight of artillery or mortars. If available, Striker teams may be added to the screen force for use against enemy vehicles.

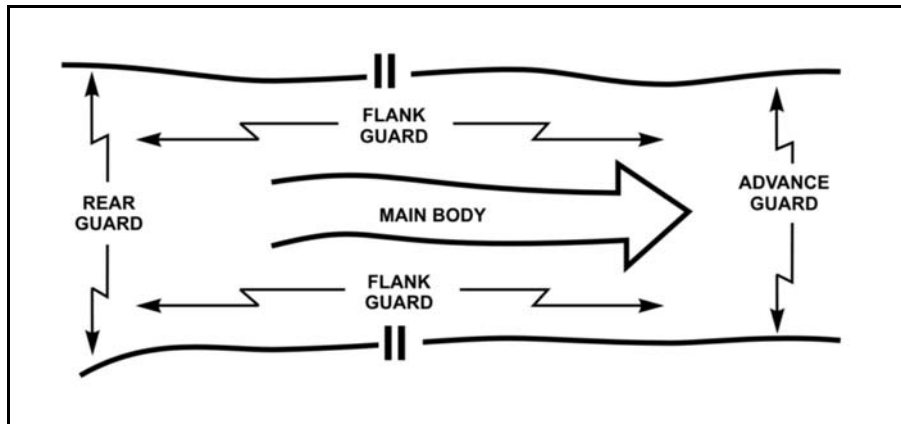
g. **Engineer Support.** Generally, the engineer effort is dedicated to the TF's main defensive area. If available, some engineer effort may be dedicated to the forward screen. The obstacle plan should not be so severe that it alters enemy movement significantly prior to its engagement by forces in the main battle area. The obstacles found forward of the MBA should be designed to delay enemy reconnaissance elements temporarily and assist in their destruction. Point-type targets along restrictive portions of the enemy's avenues of approach are an example of obstacles that may be bypassed yet offer a target to weapons covering the obstacle.

h. **Logistics.** The logistics planner must plan for responsive and flexible support that may require the immediate resupply of ammunition and evacuation of casualties and equipment upon contact. Lateral supply routes to each battle position are identified during the planning process. Moreover, on-order control measures, LRPs, UMCPs, and AXPs are essential to the operation. Emergency resupply vehicles carrying ammunition and other quickly expendable supplies, plus refuelers, are prepared to respond to sudden requisitions due to enemy contact. Once the TF begins the fight, evacuation of wounded personnel and damaged equipment occurs along lateral supply routes.

#### **4-11. GUARD**

A guard mission is assigned to protect the force by observing the enemy, reporting pertinent information, and fighting to gain time. The guard force differs from a screen force in that it contains sufficient combat power to defeat, repel, or fix the lead elements of an enemy ground force to prevent it from engaging the main body with direct fires. The guard force normally deploys over a narrower front than a comparably sized screening force, allowing greater concentration of combat power. The guard force routinely engages enemy forces with both direct and indirect fires and operates in range of the main body's indirect fire weapons. The guard force commander must understand fully the degree of security his unit provides the larger unit. This understanding is critical because, as the battle progresses, the higher unit commander may require the degree of

security to change (for example, from early warning to detailed and aggressive security for the main body). There are three types of guard operations conducted in support of a stationary or moving friendly force: rear, flank, and advance guard (Figure 4-5).



**Figure 4-5. Rear, flank, and advance guard operations.**

a. **Advance Guard.** The advance guard moves ahead of the main force to ensure its uninterrupted advance, to protect the main body against surprise, to facilitate its advance by removing obstacles and repairing roads and bridges, and to cover the deployment of the main body as it is committed to action. The advance guard is a task-organized, combined arms unit or detachment that precedes a column or formation.

(1) The advance guard is normally conducted as a movement to contact. Generally, a TF receives an advance guard mission when the brigade moves as part of the division main body in a movement to contact. In deploying an advance guard, the brigade ensures the TF has priority of fires from the DS artillery battalion. Unlike a movement to contact, however, the advance guard clears the axis of enemy elements to allow the unimpeded movement of the TF main body. The security force develops the situation to hand over the enemy to the TF. The advance guard can conduct hasty attacks if it has sufficient intelligence to overwhelm the enemy.

(2) Depending on the commander's estimate of the situation, a TF conducting an advance guard normally conducts a movement to contact with company teams advancing on axes, inAOs, or (rarely) along directions of attack.

(3) Based on METT-TC, trail elements of the advance guard must ensure they maintain adequate distance forward of the main body's lead elements to ensure freedom of maneuver for the main body. The TF commander establishes phase lines to control the movement of the main body and the advance guard. Advance guard units remain within the TF's artillery range.

(4) The advance guard force attempts to destroy enemy forces through hasty attacks. It may be necessary for the TF to mass at certain locations, destroy the enemy, report, and continue with its mission. If enemy resistance is well prepared and cannot be destroyed, the TF reconnoiters to identify a bypass route for the main body, to report enemy size and location, and (when given permission) to fix and bypass the enemy. The following attacking forces are responsible for destroying the bypassed enemy. The main body commander may elect not to bypass the enemy but to conduct a deliberate attack. In this

case, the advance guard keeps the enemy contained and prepares to pass main body elements through to eliminate the enemy.

b. **Rear Guard.** When a division conducting a movement to contact requires rear security, a TF may receive a rear guard mission. The rear guard protects the rear of the main body and all CS and CSS elements in the main body. It may accomplish this by conducting an attack, a defense, or a delay. A TF conducting a rear guard operation follows the same axis of advance as the protected force at a distance prescribed by the main body commander and normally within artillery range. The TF commander establishes company team battle positions or sectors. When using sectors, he designates phase lines and checkpoints to control movement. The rear guard's responsibility begins at the main body rear boundary and extends as far from this boundary as the factors of METT-TC allow.

c. **Flank Guard.** A TF may receive a flank guard mission during a division movement to contact. The flank guard is responsible for clearing the area from the division main body to the flank guard's designated positions. The TF must be prepared to operate on a frontage that is greater than for other tactical operations. Usually, the area extends from the lead forward screen, along the flank of the formation, to either the forward edge of the battle area (FEBA) or the rear of the moving formation, tying in with the rear guard. Due to the complexities of this operation, the following detailed discussion of flank guard operations is provided.

(1) **Templates and Analysis.** Once the TF receives a flank guard mission, the S2 determines the type of threat facing the TF during its movement. This information is critical to the commander in his selection of appropriate formation and movement techniques. The IPB must incorporate the entire area of operations with analysis of the mobility corridors and avenues of approach extending from the FEBA to the objective. The S2 produces a situational template and an event template. He develops and inputs an R&S plan with specific reconnaissance objectives for subordinate units as the enemy overlay. Subordinate units verify the S2's situational template during reconnaissance and periodically send enemy overlay updates back to the S2. The staff develops the DST to assist the commander in assessing the situation and making decisions.

(2) **Formation and Movement Techniques.** From the intelligence estimate the commander determines the formation and movement technique, accounting for the enemy situation and main body disposition. Movement techniques include--

(a) **Alternate Bounds.** The commander uses this technique when he anticipates strong enemy action against the flank. It requires slow movement by the main body.

(b) **Successive Bounds.** The commander uses this technique when he expects enemy action against the flank to be light and movement of the main body to include frequent short halts.

(c) **Moving Guard.** The commander uses this technique when he expects no enemy action on the flank and the main body will move with all possible speed. In the moving guard, an armor heavy company team executes the forward screen mission while traveling as in a movement to contact. The mortar platoon follows the forward screening company team to provide support. The scout platoon, normally with an armor section under operational control (OPCON), conducts a flank screen outside the tentative battle position line. The remaining company teams travel in column, along an axis or in sector,

behind the forward screen. The commander uses this technique when the greatest enemy danger appears to be from the front.

(3) **Fire Support.** The fire support officer plans the flank guard operation the same as any offensive operation. Based on the IPB, he targets those enemy avenues of approach that threaten the force. He targets known and suspected enemy positions along the axis of advance or in the TF zone to support the forward screening element. During the operation, the TF executes its fire support plan as it would in movement to contact and defensive operations. On the forward screen, as the TF encounters enemy positions and subsequently destroys or fixes and bypasses them, it uses artillery to suppress the position. Should the enemy attempt to attack from the flank, the TF executes the fire support plan as it would for defensive operations to support the defense or delay.

(4) **Engineer Support.** The TF engineer officer in charge of the attached engineer unit has two missions to consider in planning the flank guard mission: mobility and countermobility operations. Engineers are organized as they would be for a movement to contact. Usually, they follow the lead element and assist in negotiating any obstacles that prevent continued advance. The obstacle plan should include rapidly emplaced obstacles through a family of scatterable mines (FASCAM), ground-emplaced mine scattering system (GEMSS), or other assets. Engineers also identify key bridges or other potential obstacles during the planning process so they can render them unusable for enemy maneuver. Above all, the engineers develop a plan allowing the responsive emplacement of obstacles on short notice.

(5) **Air Defense.** The ADO develops a flexible plan to allow for the protection of the force as it changes posture between moving and stationary. He plans the TF air defense as he would in an offensive operation. Most assets are attached to maneuver elements and the main CP. Route protection or other areas go without support or rely on protection from main body ADA assets. The TF executes the air defense plan as in a movement to contact where a moving force may need to adopt a hasty defense quickly. Whether moving or stationary, air defense assets must be linked to the main body's air defense early warning net and the positioning of assets must protect not only the flank guard but also approaches into the main body.

(6) **Logistics.** The logistics planner has the same difficulties as in planning a movement to contact. He must plan for responsive and flexible support that may require the immediate resupply of ammunition and evacuation of casualties and equipment upon contact. The planner identifies lateral supply routes to each battle position during the planning process. On-order control measures, LRPs, UMCPs, and AXPs are essential to the operation. As the TF begins its movement, the TF trains should travel abreast of the flank guard unit (close to the main body) to avoid exposing CSS elements to the enemy. Emergency resupply vehicles carrying ammunition and other quickly expendable supplies, plus refuelers, are ready to respond to sudden requisitions due to enemy contact. Once the TF begins the fight, evacuation of wounded personnel and damaged equipment occurs along lateral supply routes all the way to the main body if that is where the support TF is located. Otherwise, the evacuation is back along the axis of advance.

(7) **Orientation of Forces.** A unique aspect of the flank guard mission is the orientation of the forces and the direction they may be ordered to screen. While the force maneuvers forward along its assigned axis of advance or zone, phase lines control the movement of the company team elements. There should be a phase line on either side of

each company team's battle position. The battle positions are generally larger than in a purely defensive mission, partly due to the large frontage the TF must cover. Once an element detects the enemy and company teams adopt hasty defensive positions, these phase lines become boundaries for controlling the defensive battle. This gives the TF commander the option of designating company team sectors in addition to the battle positions already identified. Similarly, control of the reserve is accomplished through phase lines and checkpoints regardless of the actual direction of the maneuver. As a minimum, the following control measures are included:

- Phase lines (revert to boundaries on contact).
- Battle positions.
- Target reference points (TRPs).
- Axis of advance.
- Axis of advance of main body.
- Objectives (if used).

#### **4-12. AREA SECURITY**

Area security refers to a force's mission to secure a specific area. Area security actions could include area reconnaissance and security of designated personnel, equipment, facilities (including airfield and seaports), main supply routes, lines of communication, and critical points. The TF is most often employed as an advance guard for a brigade, as part of a covering force for a division, or as an area security force during a stability or support action.

#### **4-13. COVER**

A covering force accomplishes all the tasks of screening and guard forces. Unlike screening or guard forces, a covering force is tactically self-contained and capable of operating independently of the main body to develop the situation early and deceive, disorganize, and destroy enemy forces. Cover may be an offensive or defensive mission. The requirements placed upon the covering force, the command and control structure necessary for the forces involved, and the large areas of operations involved require an adequate level of command for successful accomplishment. The TF performs screen and guard missions. Covering force operations are normally an armored cavalry regiment mission for the corps or a task-organized brigade for the division. A covering force, or portions of it, often becomes decisively engaged with enemy forces; therefore, the covering force must have substantial combat power to engage the enemy and still accomplish its mission. FA, engineers, air defense, intelligence resources, and CSS should be planned to support the cover mission.

### **Section III. RECONNAISSANCE**

Reconnaissance and surveillance assets obtain information about the enemy or the physical makeup of a particular area by visual or other detection methods. Successful R&S collects quick, accurate information about the enemy and terrain. R&S plans are designed to tell the commander what he needs to know in time for him to act and do as much as possible ahead of time. R&S is part of a larger, ongoing collection process that receives its direction from the mission, the commander's need for information, and, by

extension, the IPB process. These processes outline the who, what, where, when, and why of collecting intelligence.

#### 4-14. TASK FORCE RECONNAISSANCE AND SURVEILLANCE

TF reconnaissance and surveillance operations are a broad category of activities designed to support TF intelligence development, planning, and decision-making. Reconnaissance is a combined arms maneuver operation that employs the TF's reconnaissance assets to use visual or other detection methods to observe NAIs and TAIs in order to collect combat information. Surveillance involves the systematic observation of an NAI by visual, electronic, photographic, or other means. The TF S2 section analyzes and evaluates combat information collected by the scout platoon and other assets, resulting in combat intelligence. The goal of combat intelligence is to answer the TF commander's priority intelligence requirements and other intelligence requirements to enable timely and effective decision-making.

#### 4-15. FUNDAMENTALS

Successful TF reconnaissance depends on the following fundamentals:

- Appropriate reconnaissance forward.
- Reconnaissance focused on PIR, IR, and DPs.
- Reconnaissance initiated early and conducted continuously.
- Integration of TF reconnaissance with brigade reconnaissance.
- Integration of the staff in reconnaissance planning.
- Reconnaissance planned from the beginning.
- Maximized reconnaissance assets.
- Information reported, analyzed, and disseminated rapidly and accurately.

a. **Appropriate Reconnaissance Forward.** Commanders normally do not hold scout platoons and reconnaissance assets in reserve. The fluid and nonlinear nature of the modern battlefield requires that reconnaissance be continuous and aggressive throughout the AO. In some situations, the critical reconnaissance objectives may not be forward of the maneuver forces.

b. **Reconnaissance Focused on PIR, IR, and DPs.** The reconnaissance or collection plan should focus on the collection of information required to support the PIRs and provide observation of the decision points on the battlefield. The PIR derived from the commander's critical information requirements identify the information on the enemy that the commander needs to support his battlefield visualization and to make critical decisions. The PIR help the commander filter information available to him by defining what is important to mission accomplishment. The commander and S2 use PIR to focus collection efforts, which is vital considering the limited number of reconnaissance assets available at the TF level. Focusing the reconnaissance ensures that the commander's PIR and IR are answered and prevents waste of assets used in looking for the wrong information. In addition to TF PIR, there are also PIR from the brigade and higher that influence the focus of TF reconnaissance efforts.

c. **Reconnaissance Conducted Continuously and Early.** Reconnaissance, surveillance, and security are continuous processes that should be conducted 24 hours a day. For security and surveillance missions, the scout platoon should be augmented with

elements from maneuver company teams. The TF S2 should also make full use of broadcast dissemination from brigade to answer PIRs.

d. **R&S Staff Integration.** The S2 and S3 rely upon the entire staff to assist in the planning and execution of the TF reconnaissance and surveillance plan.

(1) The signal officer apprises the S2 of enemy collection and target capabilities and vulnerabilities of friendly R&S assets.

(2) The FSO coordinates indirect fires to support R&S assets and recommends necessary restrictive fire measures for troop safety.

(3) The commander or platoon leader of a designated R&S asset plans fires and targets for the element.

(4) The engineer platoon leader collects and reports information on terrain and obstacles.

(5) The air defense platoon or section leader plans air defense for the R&S assets and provides information on expected or occurring enemy air activity.

(6) The NBC officer requests and coordinates for NBC data collection and apprises the S2 of any NBC obstacles critical to R&S units in their missions.

(7) The ALO provides air movement and close air support, if requested.

(8) Combat service support considerations for R&S include--

(a) Developing TSOPs for load plans of outposts, to include--

- Establishing CSS procedures for both mounted and dismounted reconnaissance missions.
- Establishing CSS procedures for air versus ground insertion of reconnaissance assets.
- Developing procedures for both aerial and ground sustainment.

(b) Developing resupply techniques, to include--

- Using multiple and or false landing zones away from outposts as cache drop-off points.
- Predetermining the locations and times for resupply of Classes I, III, IV, V, VII, and XI.
- Establishing locations for caches on successive missions and or insertions.

(9) Combat health support considerations include--

- Determining the HSS requirements.
- Deploying trauma specialist and medical assets in DS of reconnaissance operations, as required and appropriate.
- Planning for CASEVAC/extraction operations.
- Developing HSS SOP for supporting reconnaissance elements deployed deep into enemy territory.
- Selecting evacuation sites. (Remember that all cache sites are potential casualty evacuation sites.)
- Developing TTPs for cross-forward line of own troops (FLOT) casualty extraction.
- Establishing the time for pick up and the pickup point for aerial extraction of casualties. (The last known or reported location is normally the aerial pickup point and the best time is 30 minutes prior to beginning morning nautical twilight [BMNT] or 30 minutes after ending evening nautical twilight [EENT].)

- Developing a detailed plan for ground extraction, to escort to casualty exchange point.
- Conducting rehearsals for day and night extractions.
- Requesting escort.

If a member or members of the reconnaissance element become casualties during reconnaissance missions, initial care will be self-aid, combat lifesaver (CLS) advanced first aid, or EMT from a trauma specialist. Trauma specialists may be deployed as a rider in one of the scout vehicle or an ambulance team may be in support. See FM 4-02.4 for additional information on providing HSS for the reconnaissance elements.

e. **Maximize Reconnaissance Assets.** The TF must maximize the capabilities of its limited reconnaissance assets. It must ensure that collection requirements specify exactly what needs to be collected and where and when it needs to be collected and reported for the TF to conduct its operations. Additionally, the TF S2 must make sure he does not send the scout platoon to obtain information that may already be available through brigade assets. Close coordination and integration with the brigade S2 is required to ensure that the brigade and TF assets are not being double-tasked to find the same information.

f. **Rapid and Accurate Reporting, Processing, and Dissemination.** The TF scout platoon and other assets tasked to conduct reconnaissance must report what they observe accurately and in a timely manner. Digitization speeds both the accuracy of the intelligence gathered as well as the timeliness with which it can be sent. Once the combat information arrives, the TF S2 rapidly evaluates and disseminates it to the company teams and passes it on to the brigade. He does so over FM voice or digitally through remote workstations (RWSs) and FFCB2.

#### 4-16. CAPABILITIES

The scout platoon is the TF's primary means of conducting reconnaissance and surveillance. The scout platoon provides early warning and helps control movement of the TF or its elements. The scout platoon is normally under TF control but may be attached to another unit in the TF for certain operations. The reconnaissance elements are finders, not fighters. They are the eyes and ears, not the fists, of the TF.

a. **Considerations.** The following considerations apply to employment of the scouts.

(1) The distance scouts can operate away from the main body is restricted to the range of communications and the range of supporting indirect fire.

(2) TF scout platoons can be easily over-tasked since they have only six reconnaissance platforms with which to conduct reconnaissance.

(3) Scouts are limited in their ability to destroy or repel enemy reconnaissance units.

(4) Reconnaissance and surveillance missions are usually continuous operations that require careful planning for the employment and rest of soldiers.

(5) With only three men in each team, scout platoons are limited in their ability to conduct dismounted operations.

(6) Lack of stabilized thermal imaging optics limits night observation.

b. **Types of Reconnaissance.** The S2 coordinates reconnaissance requirements with the S3, who supervises the scout platoon during its operations. The platoon may report directly to the TF commander. Whether mounted or dismounted, reconnaissance requires the same preparation and stealth as any other operation. The three types of



reconnaissance operations--route, zone, and area--require similar techniques, but the mission dictates the type of information required.

(1) **Route Reconnaissance.** A route reconnaissance obtains detailed information about specific routes. Examples include road and bridge classification, obstacles, chemical or radiological contamination, proximity of enemy, and terrain that, if occupied or controlled by the enemy, affects TF movement. The number of routes reconnoitered by the scout platoon depends on the length of the routes, the enemy situation, and the nature of the routes themselves. When enemy contact is likely or expected or when the route is long and stretches through difficult terrain, the entire scout platoon may be required for that one route. If routes are short and enemy contact is unlikely, the platoon reconnoiters as many as three routes (one for each section) but no more.

(2) **Zone Reconnaissance.** A zone reconnaissance involves the detailed reconnaissance of an entire zone defined by boundaries. Its purpose is to obtain detailed information on all enemy, terrain, and routes within the zone. The commander states his intent for a zone reconnaissance, which may be to determine the best routes, to move through the zone, or to locate an enemy force.

(a) The commander normally assigns a zone reconnaissance mission when the enemy situation is unclear or when he desires information on cross-country trafficability. The width of a zone that a scout platoon reconnoiters depends on the type of enemy force and terrain.

(b) The zone to be reconnoitered is defined by lateral boundaries, a line of departure, and the objective. The objective provides a termination point for the mission and might be occupied by the enemy. A phase line can also be used as a termination point.

(3) **Area Reconnaissance.** An area reconnaissance obtains information about a specified area such as a town, ridge, woods, or other feature critical to operations. The commander must specify exactly what to look for and why. The area to be reconnoitered is designated by a boundary line that encircles it. Area reconnaissance differs from zone reconnaissance in that the unit moves to the assigned area by the most direct route. Once in the area, the platoon reconnoiters in detail using zone reconnaissance techniques.

#### **4-17. INTEGRATION OF BRIGADE RECONNAISSANCE TROOP AND TASK FORCE SCOUT PLATOONS**

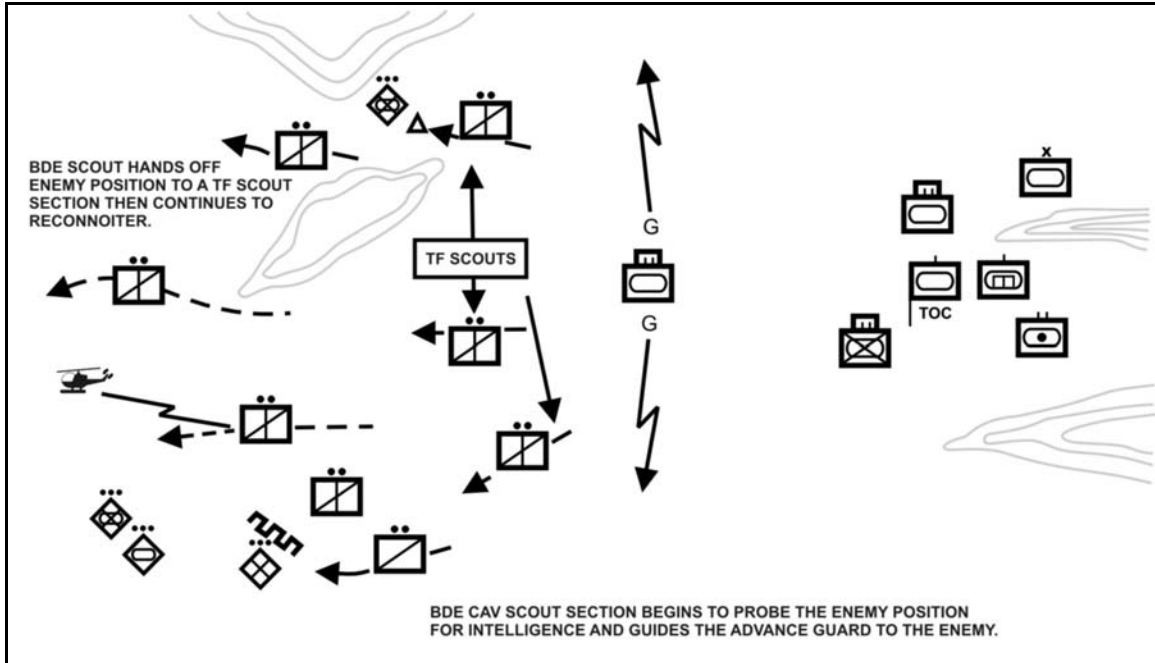
There are numerous ways the TF scout platoon and the BRT can work together to perform their reconnaissance missions.

a. **In the Offense.** During a brigade movement to contact, the BRT is normally forward of the TFs. During the approach to the objective phase, the BRT and TF scouts may do the following (Figure 4-6):

(1) The BRT may hand over key OP positions to TF scouts as they advance through sector.

(2) The BRT may vector the TF scouts into position and keep them informed about terrain, enemy positions, and obstacles that have already been found.

(3) TF scouts can provide overwatch for the BRT scouts moving to their next series of OPs or conducting reconnaissance of the area or zone.



**Figure 4-6. Brigade reconnaissance troop and TF scout employment during brigade movement to contact.**

b. **In the Defense.** In the defense, the primary mission of the scout platoon is to provide security and early warning for the task force. TF scouts may also be integrated into the brigade counterreconnaissance mission. TF and brigade scouts provide stealthy observation and early warning of the enemy's reconnaissance elements. The scout teams locate the enemy reconnaissance forces and then vector the counterreconnaissance elements to them (Figure 4-7, page 4-28). The scouts maintain a low signature by not engaging any targets. Tanks and Bradley fighting vehicles (BFVs) in the counterreconnaissance team kill the enemy reconnaissance. The data provided by digitization allows the scouts and counterreconnaissance team to execute a much more fluid and dynamic counterreconnaissance fight with less chance of fratricide.

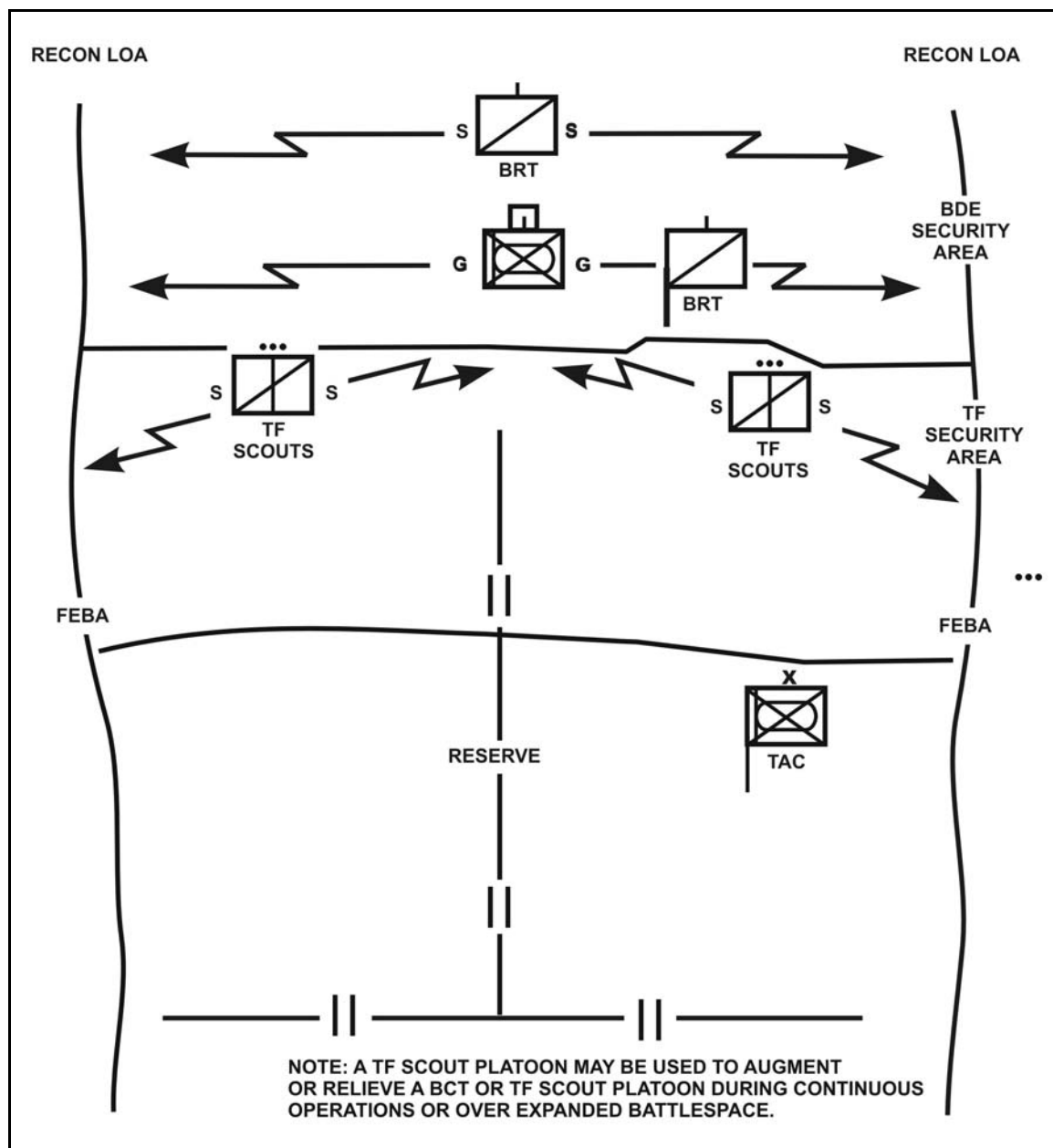
(1) The employment and coordination of the TF scouts and BRT in the counterreconnaissance operation is unit- and SOP-driven. Brigade and TF scouts can be employed in depth to provide multiple screens for the counterreconnaissance force. The brigade scouts and counterreconnaissance team occupy the most forward positions. TF scouts screen behind the brigade counterreconnaissance force with each TF employing a platoon-size counterreconnaissance force to its front.

(2) Unit SOP must address procedures for inoperative scout communications systems. Scouts with inoperative systems risk fratricide; the CP should account for them by analog methods and with manual input of platforms into the informational picture. Command posts must also have some method of tracking the operational status of each scout's FBCB2 systems.

(3) In order for the TF scout platoon and BRT to work together, the TF and brigade staffs need to coordinate the following:

- Communications and digital architecture.
- Command and control architecture.

- Terrain management.
- NAI coverage and intelligence gaps.
- Fire support control measures.
- Fratricide avoidance measures.



**Figure 4-7. Counterreconnaissance organization of brigade reconnaissance troop and TF scout platoon.**

**4-18. SUPPORTING ASSETS NORMALLY AVAILABLE TO TASK FORCE**

TF commanders may have access to R&S assets from brigade and higher to include UAVs, Striker teams from the field artillery battalion, and possibly Army aviation reconnaissance assets working forward of the TF. Building the R&S plan forces

consideration of maneuver, fire support, engineer placement, and C3 to link the plan seamlessly to the security force and maneuver plans. Higher headquarters normally specifies a time to forward a copy of the plan. The S2 should push the security assets out as soon as possible; the sooner the reconnaissance and surveillance assets are out looking, the more time they will have to find what the commander needs. Without a basic reconnaissance and surveillance plan, SOPs regarding default addressing, message preferences, and filter settings, reconnaissance efforts become fruitless and frustrating. The TF can use an SOP to start early reconnaissance and update the units with FRAGOs as the R&S plan is completed. Commanders specify limits of responsibility for early reconnaissance, updating them as needed.

---

## CHAPTER 5

# OFFENSIVE OPERATIONS

*Offensive action is the decisive form of battle. The primary purpose of the offense is to defeat, destroy, or neutralize an enemy force. A commander may also take offensive actions to deceive or divert the enemy, deprive him of resources or decisive terrain, develop intelligence, or hold an enemy in position. Even in the defense, offensive action is normally required to destroy an attacker and exploit success. The key to a successful offensive operation is to identify the enemy's decisive point and choose a form of maneuver that avoids the enemy's strength and masses overwhelming combat power in order to achieve a result with respect to terrain, enemy, and time that will accomplish the unit's purpose. This chapter discusses the basics of the offense, which apply to all offensive actions. It discusses the concept of coordinated mechanized infantry and armor attacks and the planning and conduct of offensive operations.*

*The four types of offensive actions are movement to contact, attack, exploitation, and pursuit. The TF seizes, retains, and exploits the initiative in conducting offensive operations. Offensive operations are either force-oriented (focused on the enemy) or terrain-oriented (focused on seizing or securing terrain and facilities). Most offensive operations at TF level combine distinct subunit operations that have force or terrain orientations.*

### Section I. FUNDAMENTALS OF OFFENSIVE OPERATIONS

The TF gains and maintains the initiative and keeps constant pressure on the enemy throughout his battle space. The TF transitions from one offensive action to another without pausing. Planning and preparing for the next operation and for follow-on operations occur simultaneously with execution of the current action.

#### 5-1. CHARACTERISTICS OF OFFENSIVE OPERATIONS

Success in offensive operations depends on the proper application of the fundamental characteristics of the offense discussed in the following paragraphs. The TF's ability to maneuver mounted or dismounted makes flexibility a key attribute.

a. **Surprise.** A force achieves surprise by attacking the enemy at a time or place and in a manner for which the enemy is not physically or mentally ready. The TF commander must have sufficient information for a clear understanding of his current state in relation to the enemy and environment, a sound understanding of what the end state is for the assigned mission, and a vision of how to move his force from the current situation to the end state. Surprise is more readily attainable because of the TF's information dominance, flexibility, and mobility. A TF achieves surprise by--

- Gaining and maintaining information dominance by conducting thorough ISR and counterreconnaissance efforts.
- Striking the enemy from an unexpected direction at an unexpected time through the unique combination of rapid mounted movement and the ability of units to cross any type of terrain.

- Quickly changing the tempo of the operations.
- Being unpredictable.

b. **Concentration.** A force achieves concentration by massing the effects of combat power. Superior timing, precision maneuvers, and speed, facilitated by shared information dominance, allows the TF commander to mass the effects of his forces when and where appropriate and to shift from one objective or direction to another quickly. Because the commander has the advantage in information being received, he has a better understanding of the effects of his action (“seeing” success or the need to continue an attack) and can apply available combat power more efficiently and focus his main effort more effectively. Once it gains success, the TF can quickly disperse, if needed, to avoid enemy counteractions, again under control enabled by understanding. A TF achieves concentration through--

- Careful planning and coordination based on a thorough terrain and enemy analysis plus accurate, timely reconnaissance.
- Designation of a main effort and allocation of resources to support it.
- Continuous information flow.
- Positioning of units that allows them to mass effects.

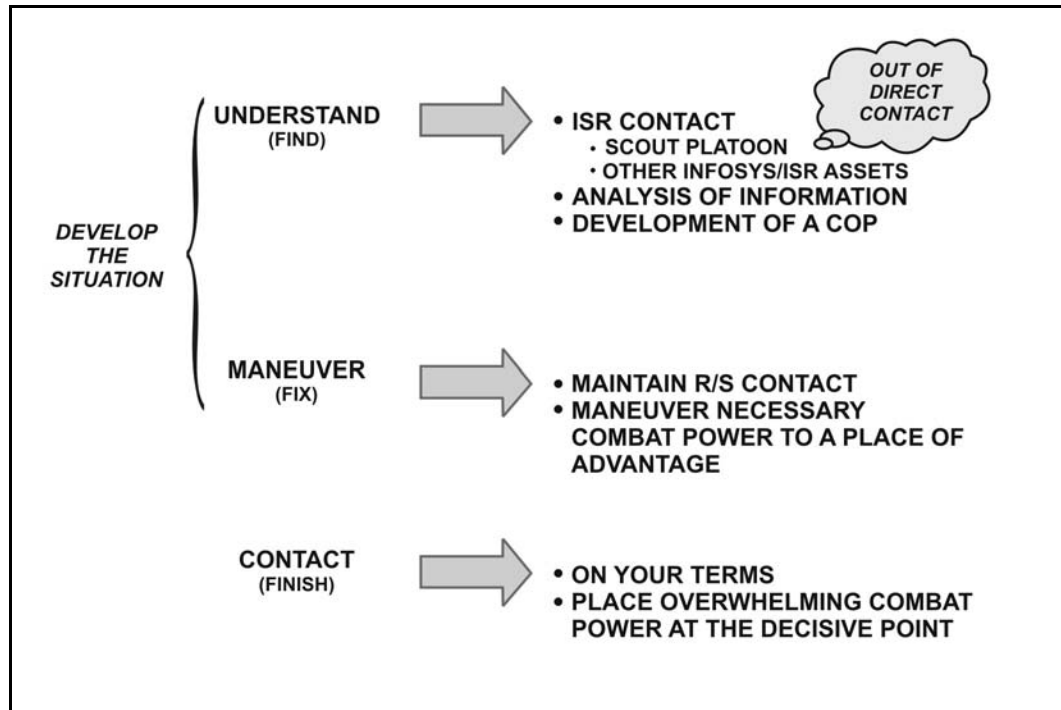
c. **Tempo.** Tempo is the ability to adjust the rate of operations relative to battle circumstances and relative to the enemy’s capability to sense and react. It is the controlled rate of military action. While a rapid tempo is often preferred, the tempo should be adjusted to ensure synchronization. The goal is to keep pressure on the enemy whether it is done quickly or slowly. Controlling and altering tempo promotes surprise, keeps the enemy off balance, denies the enemy freedom of action, and contributes to the security of the TF. The TF’s advanced information systems and rapid mobility capabilities facilitate a rapid mounting tempo while permitting the synchronization necessary for a rapid execution tempo.

d. **Audacity.** Audacity is a simple plan of action, boldly executed. Audacity inspires soldiers to overcome adversity and danger. Audacity is a key component of any successful offensive action and increases the chance for surprise. It depends on the commander’s ability to see opportunities for action, to decide in time to seize opportunities, and to accept the risks. Leaders must understand when and where to take risks, plan for them, and execute boldly. The sharing of combat information electronically between leaders at all echelons reduces the risk but does not eliminate the many uncertainties associated with battle. Digitization improves the commander’s ability to make quick situational assessments, to conduct on-the-spot risk assessments, and to make bold decisions based on near-real-time information.

## 5-2. CONTACT CONTINUUM

Traditionally, the TF made contact with the scout platoon and lead company team to develop the situation while in contact with the enemy. The lead company team then fixed the enemy, allowing the remainder of the TF to maneuver against an assailable flank. This method was based on the TF's ability to overwhelm the enemy with greater available combat power. With the reduction of combat power in the TF and additional INFOSYS within the TF, a new method of making contact is required. This new contact continuum consists of understanding the situation and maneuvering to a position of advantage in order to make contact with the enemy on the TF's terms (Figure 5-1). Within this new

contact continuum, the TF can mass overwhelming combat power at the decisive point to achieve the TF purpose more efficiently and effectively.



**Figure 5-1. Contact continuum.**

### 5-3. ORGANIZATION OF OFFENSIVE OPERATIONS

Commanders organize forces according to purpose by determining whether each unit's operation will be decisive, shaping, or sustaining. The purpose-based framework centers on decisive, shaping, and sustaining operations. Purpose unifies all elements of the battlefield organization by providing the common focus for all actions. However, forces act in time and space to accomplish a purpose. These decisions form the basis of the concept of operations. Alternatively, commanders may choose to use the 'decisive point,' 'main effort,' or 'supporting efforts' method to articulate his organization of forces if this better facilitates the commanders ability to visualize, describe, and direct actions, especially since battalion task forces operate at the tactical level of war. Commanders also synchronize operations in time and space. When circumstances require a spatial reference between friendly and enemy forces, commanders may describe them in terms of deep, close, and rear areas. These spatial categories are especially useful in combat operations that are generally contiguous, linear, and feature a clearly defined enemy force.

a. **Decisive Operations.** Decisive operations directly achieve the mission and intent of the higher headquarters. Decisive operations conclusively determine the outcome of battles and engagements. There is only one decisive operation for any major operation, battle, or engagement for any given echelon. The decisive operation may include multiple actions conducted simultaneously throughout the depth of the AO. Commanders weigh the decisive operation while economizing on the effort allocated to shaping operations.

(1) In the offense and defense, decisive operations normally focus on maneuver. Conversely, logistics may be decisive during the mobilization and deployment phases of an operation or in support operations, particularly if the mission is humanitarian in nature.

(2) A reserve is a portion of a body of troops that is kept to the rear or withheld from action at the beginning of an engagement but remains available for a decisive movement. Until committed, reserves shape through their placement within the AO while planning for and preparing to conduct operations. When committed, they usually either become the decisive operation or reinforce the decisive operation. Commanders can use reserves to influence circumstances or exploit opportunities. When commanders anticipate uncertainty, they hold a greater portion of the force in reserve, posturing the force to seize and maintain the initiative as a situation develops. Reserves deploy and reposition as necessary to ensure their protection, availability, and prompt reaction.

**b. Shaping Operations.** Shaping operations create and preserve the conditions for the success of the decisive operation. Shaping operations include lethal and nonlethal activities conducted throughout the AO. They support the decisive operation by affecting the enemy's capabilities and forces or influencing the opposing commander's decisions. Shaping operations use the full range of military power to neutralize or reduce enemy capabilities. They may occur simultaneously with, before, or after initiation of the decisive operation. They may involve any combination of forces and occur throughout the depth of the AO.

(1) Some shaping operations, especially those that occur simultaneously with the decisive operation, are economy-of-force actions. If the force available does not permit simultaneous decisive and shaping operations, the commander sequences shaping operations around the decisive operation. A shaping operation may become the decisive operation if circumstances or opportunity demand. In that case, commanders weigh the new decisive operations at the expense of other shaping operations. The concept of the operation clearly defines how shaping operations support the decisive operation.

(2) Security is an important shaping operation. Security enables the decisive operation of the next higher headquarters. Security protects the force and provides time for friendly forces to react to enemy or hostile activities. It also blinds the enemy's attempts to see friendly forces and protects friendly forces from enemy observation and fires.

**c. Sustaining Operations.** The purpose of sustaining operations is the generation and maintenance of combat power.

(1) Sustaining operations are operations at any echelon that enable shaping and decisive operations by providing CSS, rear area and base security; movement control; terrain management; and infrastructure development. Sustaining operations include the following elements.

(a) CSS generates and sustains combat power. While balancing the necessity of security, CSS provides essential capabilities, functions, activities, and tasks necessary to sustain all elements of the operating forces in-theater. CSS encompasses those activities at all levels of war that generate and maintain forces on the battlefield.

(b) Rear area and base security include measures taken by a military unit, an activity, or an installation to defend and protect itself against all acts that may impair its effectiveness. It has four components--intelligence, base and base cluster self-defense,



response force operations, and combined arms tactical combat force (TCF) operations (see FM 100-7).

(c) Movement control includes the planning, routing, scheduling, controlling, and security of the movement of personnel and materiel into, within, and out of the AO. Maintaining movement control, keeping LOC open, and obtaining host nation support are critical requirements in preserving freedom of movement throughout the AO.

(d) Terrain management includes the process of allocating terrain, designating assembly areas, and specifying locations for units and activities. The process includes grouping units together to form bases and designated base clusters as necessary.

(e) Infrastructure development applies to all fixed and permanent installations, fabrications, or facilities that support and control military forces. Infrastructure development focuses on facility security modifications and includes area damage control (ADC) and repairs.

(2) Sustaining operations are inseparable from decisive and shaping operations, although they are not by themselves decisive or shaping. Failure to sustain normally results in mission failure. Sustaining operations occur throughout the AO not just within the rear area. Sustaining operations determine how quickly forces reconstitute and how far forces can exploit success. At the tactical level, sustaining operations underwrite the tempo of the overall operation; they assure the ability to take advantage of any opportunity immediately.

d. **Main Effort.** In a TF, there is only one main attack which includes the main effort and may include one or more supporting efforts. All other elements of the TF support the main attack. In planning the scheme of maneuver, the main attack must have sufficient combat power and support to accomplish its mission. The main effort accomplishes the TF's purpose, normally at the decisive point. After designating the main effort, the commander ensures all available resources are focused on supporting it and places the bulk of the offensive capability at his disposal into it. To weight the main effort, the commander may--

- Assign the main attack to the company team(s) with the greatest combat power.
- Allocate additional combat platoons in task organization.
- Attach combat support elements in DS.
- Position overwatch or support by fire elements to support.
- Assign priority of fires (artillery, mortars, and CAS) and priority of targets.
- Coordinate adjacent unit or attack helicopter support by fire.
- Assign priority of CSS.
- Narrow the scope of the main effort's responsibility in terms of geographical area or specified tasks.

(1) Enemy actions, minor changes in the situation, or lack of success by other elements must not divert forces from the main effort. The commander commits the main effort at the decisive point where the unit's total combat power can be massed to achieve decisive results with respect to terrain, the enemy, and time in order to achieve the unit's purpose. Once committed, the unit may--

- Secure key and or decisive terrain.
- Seize key and or decisive terrain.
- Destroy designated enemy forces.

(2) If the situation changes so that the actions originally anticipated as decisive are no longer feasible or relevant, the commander may change the unit designated to conduct the main effort during the course of an operation. Rapidly shifting the main effort as changes in the situation occur is challenging. Time and distance factors determine which forces the commander uses if he shifts the main effort.

e. **Reserve.** The TF designates a reserve when the brigade has no reserve or an inadequate reserve or when faced with an uncertain situation that requires flexibility in the plan. The reserve provides additional combat power during critical points in the fight, the ability to exploit the success of the main effort, and a hedge against uncertainty. The reserve should be sized to mitigate risk and based on the level of detail known about the enemy. The TF's information dominance over the enemy allows the commander to capitalize on the capabilities of digitization to apportion his available troops to the tasks required to effect his concept of attack. The composition of the reserve is based on the firepower, mobility, and type of forces needed to meet its anticipated mission requirements based on the enemy. Solid intelligence can lead the commander to concentrate his committed units against a specific enemy weak point(s) and identify reserve requirements.

(1) The TF reserve can be as small as an infantry platoon. The commander and staff must look for opportunities to use other assets, such as fires and situational obstacles, to assist with the reserve mission. To generate larger ground maneuver reserves, the commander must redirect committed elements after they have accomplished their initial tasks or when the enemy's defeat frees them for other tasks.

(2) The speed and agility of the combat platoons allow them to be committed, withdrawn, redirected, and recommitted during the fight. The rotation of units into the reserve role requires the best possible information available. Moving a unit from one area (left to right or front to rear) requires everyone in the unit to know where he is, where the enemy is, and where other friendly units are. Additionally, the movement of ground forces over the distances expected in the expanded battlespace requires time. The time and distance relationship for both mounted and dismounted actions, especially under limited visibility conditions and rough terrain, is a key factor in determining which units the commander can realistically consider as a possible reserve force.

(3) The TF reserve follows the main attack at a distance sufficient to keep it from interfering with the movement of the lead company teams and to maintain its freedom of maneuver. The reserve maintains the flexibility to shift to a supporting attack if the main effort changes.

(4) The reserve commander must understand the commander's intent, especially the decision points and conditions for commitment of the reserve. The reserve commander must remain updated on the situation and possess the same combat operational picture as the TF commander.

f. **Follow and Support.** In exploitation and pursuit operations, the TF is normally employed by higher formations in a follow and support role.

(1) Follow and support is a task in which a committed force follows and supports the unit conducting the main attack. A follow and support task is assigned to a unit to prevent the unit conducting the main attack (usually the TF main effort) from having to commit its combat power away from its primary task. A follow and support force executes one or more of the following tasks:

- Destroy bypassed enemy forces.
- Block movement of enemy reinforcements.
- Secure routes or key terrain.
- Clear obstacles or reduce additional obstacle lanes.
- Guard or secure enemy prisoners, key areas, and installations.
- Recover friendly battle losses.
- Control refugees.
- Reinforce the main effort.

(2) When operating as a follow and support force, the TF's movement techniques are similar to those used in a movement to contact. The TF coordinates plans with the unit it follows. Both units exchange situation reports frequently to coordinate operations.

g. **Follow and Assume.** Follow and assume is a task in which a committed force follows another force, normally the main effort, and is prepared to assume the mission of the other force if that force is fixed, halted, or unable to continue. The follow and assume force maintains contact with the trail elements of the other force and monitors all combat information and intelligence. It can maintain this contact through digital tools or by physical contact. The COP should provide the same picture of the battle to the follow-on force as is available to the lead force.

(1) The follow and assume force is prepared to conduct a forward passage of lines but should attempt to pass around a flank of the lead force when assuming its mission. Additionally, the following force avoids becoming decisively engaged with enemy forces bypassed by the force it is following. The S2 must ensure that the following force is provided current information and disposition of the bypassed enemy forces as well as a current picture of the enemy forces the lead element faces and those it expects to face.

(2) Crucial actions to support the commitment of the follow and assume force include:

- Maintain current information on the enemy and friendly situation.
- Shift observers and reconnaissance assets as required.
- Develop graphic control measures to ensure a rapid passage of lines or passing on a flank.
- Ensure terrain is allocated for rapid movement while maintaining force protection.
- Be prepared for the shift in priority of CS and CSS support. Reposition assets and re-task-organize as required.
- Activate emergency resupply operations as necessary.
- Establish direct fire control measures and FSCMs such as restrictive fire lines (RFLs).

## **Section II. FORMS OF MANEUVER**

The TF uses the five basic forms of maneuver during an attack: envelopment, turning movement, infiltration, penetration, and frontal attack. The commander selects a form of maneuver as a foundation upon which to build a COA.

### **5-4. ENVELOPMENT**

Envelopment is normally the preferred form of maneuver. It seeks to apply strength against weakness. Envelopment avoids the enemy's front where forces are most

protected, attention is focused, and fires are most easily concentrated. The attacker attempts to fix the defender with supporting attacks while he maneuvers the main attack around the enemy's defenses to strike at the flanks, rear, or both. The TF's intelligence capabilities enable it to strike from an unexpected direction or against an enemy weakness, forcing the enemy to fight along unprepared, lightly defended, or undefended avenues of approach. The TF fixes the enemy force with a small force then attacks with the preponderance of available combat power against the enemy force's flank or rear.

a. Envelopments may be conducted against a stationary or moving enemy force. Sometimes the enemy exposes his flank by his own forward movement, unaware of his opponent's location. In a fluid battle, the combination of air and indirect fires may isolate the enemy on unfavorable terrain and establish conditions for maneuver against an assailable flank or rear. The attacker needs to be agile enough to concentrate his forces and mass his combat power before the enemy can reorient his defense (Figure 5-2).

b. When the TF conducts envelopment, one or more company teams make supporting attacks to fix the enemy while other company teams of the TF maneuver against the enemy's flank or rear. The supporting attack must have sufficient combat power to keep the enemy engaged while the enveloping force maneuvers to close with the enemy.

c. Variations of the envelopment include the double envelopment and encirclement.

(1) **Double Envelopment.** The attacker seeks to pass at the same time around both flanks of the enemy. This type of envelopment requires two assailable flanks, precise coordination, sufficient combat power, and detailed timing. A TF seldom attempts the double envelopment on its own. The potential for fratricide increases significantly with this form of envelopment.

(2) **Encirclement.** Encirclement occurs when the defender has lost all ground routes of evacuation and reinforcement. TF fires must be synchronized to complete the destruction of the encircled force. Forces must be positioned to block or interdict the enemy's attempt to break through the encirclement. Encirclements are likely to be made during an exploitation or pursuit. TFs participate in encirclements as part of a larger force.

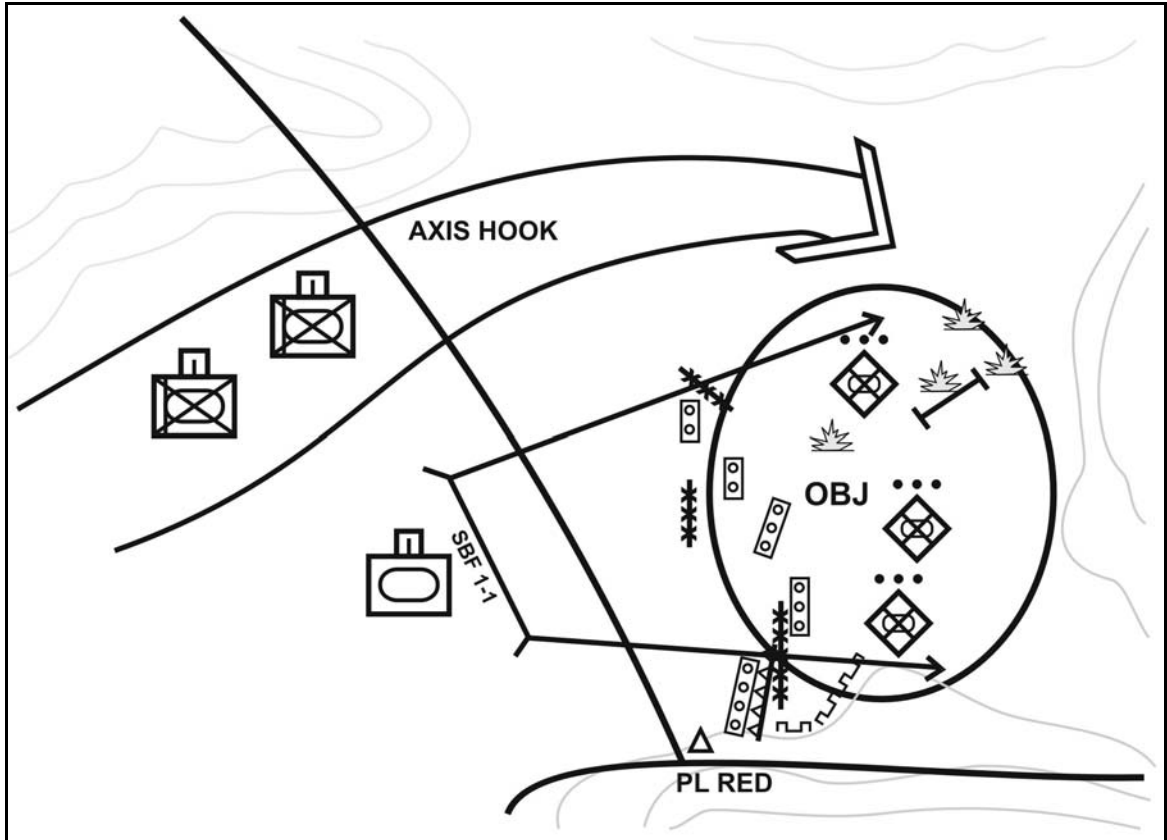


Figure 5-2. Envelopment.

### 5-5. PENETRATION

In a penetration, the attacker concentrates forces to strike at an enemy weak point and break through the position to rupture the defense and break up its continuity. The attacker then uses the gap created to pass forces through to defeat the enemy through attacks into his flanks and rear. A successful penetration depends on the attacker's ability to suppress enemy weapons systems, to concentrate forces to overwhelm the defender at the point of attack, and to pass sufficient forces through the gap to defeat the enemy quickly. A penetration is normally attempted when enemy flanks are unassailable or when conditions permit neither envelopment nor a turning movement such as an attack against the enemy's main defensive belt (Figure 5-3, page 5-10).

a. **Concentration.** The penetration of an enemy position requires a concentration of combat power to permit continued momentum of the attack. The attack should move rapidly to destroy the continuity of the defense since, if it is slowed or delayed, the enemy will be afforded time to react. If the attacker does not make the penetration sharply and secure objectives promptly, the penetration is likely to resemble a frontal attack. This may result in high casualties and permit the enemy to fall back intact, thus avoiding destruction.

b. **Steps.** A penetration is conducted in the following three steps:

(1) **Step 1: Penetrating the Main Line of Resistance.** A mechanized heavy company team can execute the initial penetration. It breaches the enemy's obstacles using

mineplows, mine clearing line charges (MICLICs), or dismounted infantry squads, depending on the extent and composition of the obstacles.

(2) **Step 2: Widening the Gap to Secure the Flanks.** The TF seizes enemy positions behind the obstacles and widens the shoulders of the penetration to allow assaulting forces room to attack deep objectives.

(3) **Step 3: Seizing the Objective and Subsequent Exploitation.** Exploitation of the penetration is made as company teams complete the destruction of the enemy and attack to secure deeper objectives. Objectives for the assaulting force are deep enough to allow an envelopment of the rest of the enemy position and should facilitate attack by fire against second echelon enemy positions and enemy counterattack routes.

c. **Planning Considerations.** To allow a penetration, the terrain must facilitate the maneuver of the penetrating force. The concentration of the TF is planned to penetrate the defense where the continuity of the enemy's defense has been interrupted, such as gaps in obstacles and minefields or areas not covered by fire. If METT-TC analysis identifies multiple weaknesses in the enemy's position, multiple penetrations should be considered. When essential to the accomplishment of the mission, intermediate objectives should be planned for the attack.

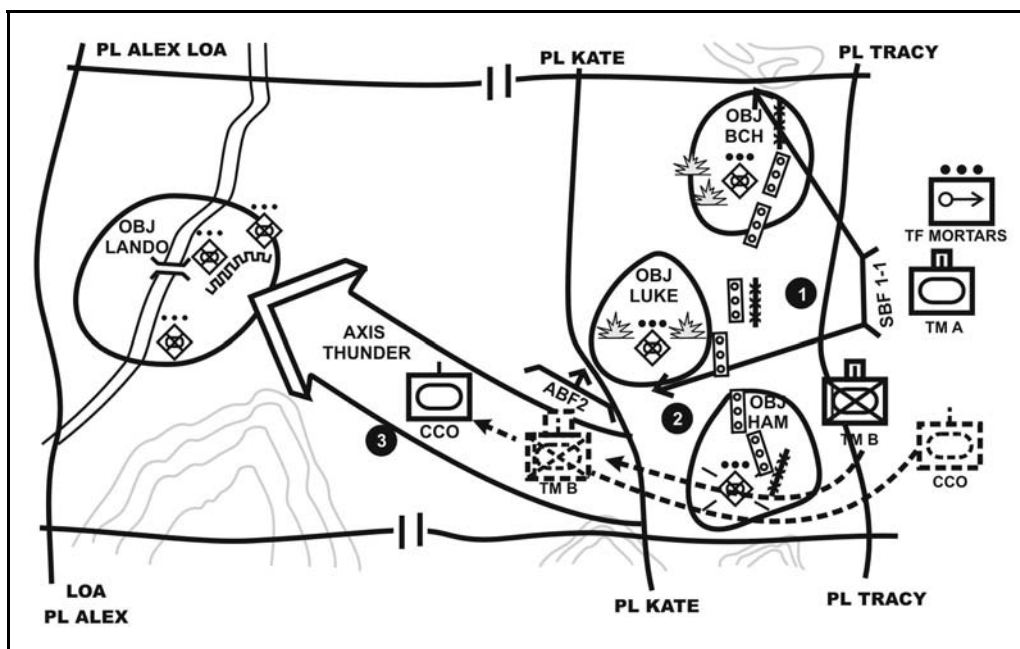
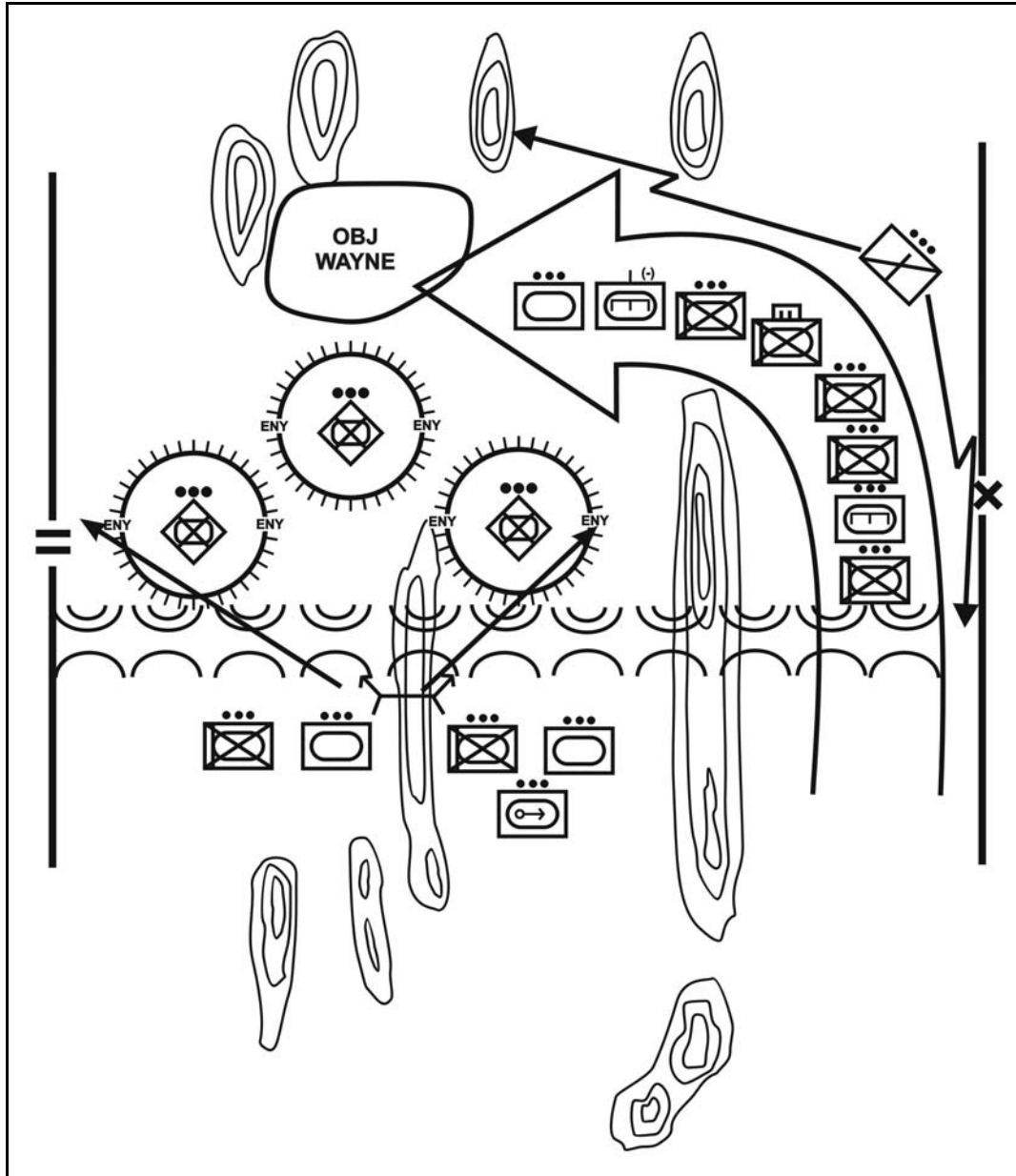


Figure 5-3. Penetration.

## 5-6. TURNING MOVEMENT

In a turning movement (Figure 5-4), the unit passes around and avoids the enemy's main force, then secures an objective that causes the enemy to move out of its current position or divert forces to meet the threat. The TF conducts a turning movement as part of a larger unit's operation. This movement allows the unit, brigade or higher, to fight the repositioning enemy forces on terms and conditions that are favorable. The TF can also conduct a turning movement with subordinate company teams.



**Figure 5-4. Turning movement.**

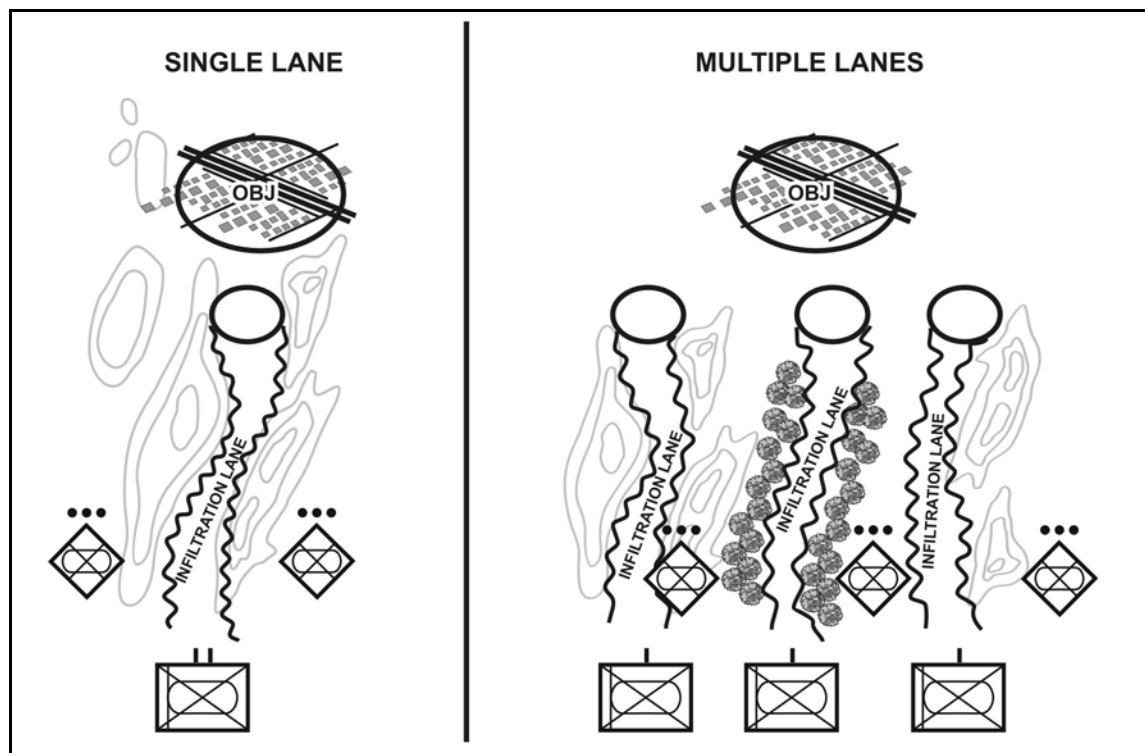
### 5-7. INFILTRATION

Infiltration (Figure 5-5, page 5-12) is a form of maneuver in which combat elements conduct undetected movement (mounted or dismounted) through or into an area occupied by enemy forces to occupy a position of advantage in the enemy's rear. The commander uses infiltration to--

- Attack lightly defended positions or stronger positions from the flank and rear.
- Secure key terrain in support of the main effort.
- Disrupt enemy rear operations.
- Relocate the TF by moving to battle positions around an engagement area.

- Reposition to attack vital facilities or enemy forces from the flank or rear.
  - Harass and disrupt the enemy's CSS.
- a. **Planning Considerations.** The commander avoids alerting the enemy of his intentions by positioning maneuver and artillery units and the effects of fires in support of the infiltration. Infiltration is normally used in conjunction with some other form of maneuver. An infiltration should be planned during limited visibility through areas the enemy does not occupy or cover by surveillance and fire. Planning should incorporate infiltration lanes, rally points along the route or axis, and contact points. Single or multiple infiltration lanes can be planned.

- (1) **Single Infiltration Lane.** A single infiltration lane--
- Facilitates navigation, control, and reassembly of the TF.
  - Is less susceptible to detection.
  - Reduces the area for which detailed intelligence is required.
  - Takes longer to move the force through enemy positions.
- (2) **Multiple Infiltration Lanes.** Multiple infiltration lanes--
- Reduce the possibility of compromising the entire TF.
  - Facilitate expeditious movement.
  - Are more difficult to control.



**Figure 5-5. Infiltration.**

- b. **Vehicle Laager.** The task force has the ability to laager its vehicles and proceed on foot to areas that place the enemy at a disadvantage. Upon completion of the mission, the vehicles can be brought forward and the TF will be positioned to conduct follow-on operations. The commander avoids alerting the enemy of his intentions by positioning



maneuver and artillery units and the effects of fires in support of the infiltration. Infiltration is normally used in conjunction with some other form of maneuver.

### 5-8. FRONTAL ATTACK

The frontal attack is the least desirable form of maneuver and is often the most costly since it exposes the majority of the attack force to the concentrated fires of the defenders. It can be used where speed and simplicity are essential to maintain tempo and the initiative. The TF may conduct a frontal attack (Figure 5-6) against a stationary or moving enemy force. Unless frontal attacks are executed with overwhelming speed and strength against a weaker enemy, they are seldom decisive. The TF attacks the enemy across a wide front and along the most direct approaches. It uses a frontal attack to overrun and destroy a weakened enemy force or fix an enemy force. Frontal attacks are used when commanders possess overwhelming combat power and the enemy is at a clear disadvantage or when fixing the enemy over a wide front is the desired effect and a decisive defeat in that area is not expected. The frontal attack may be appropriate--

- In an attack or meeting engagement where speed and simplicity are paramount to maintaining battle tempo and, ultimately, the initiative.
- In a supporting attack to fix an enemy force.

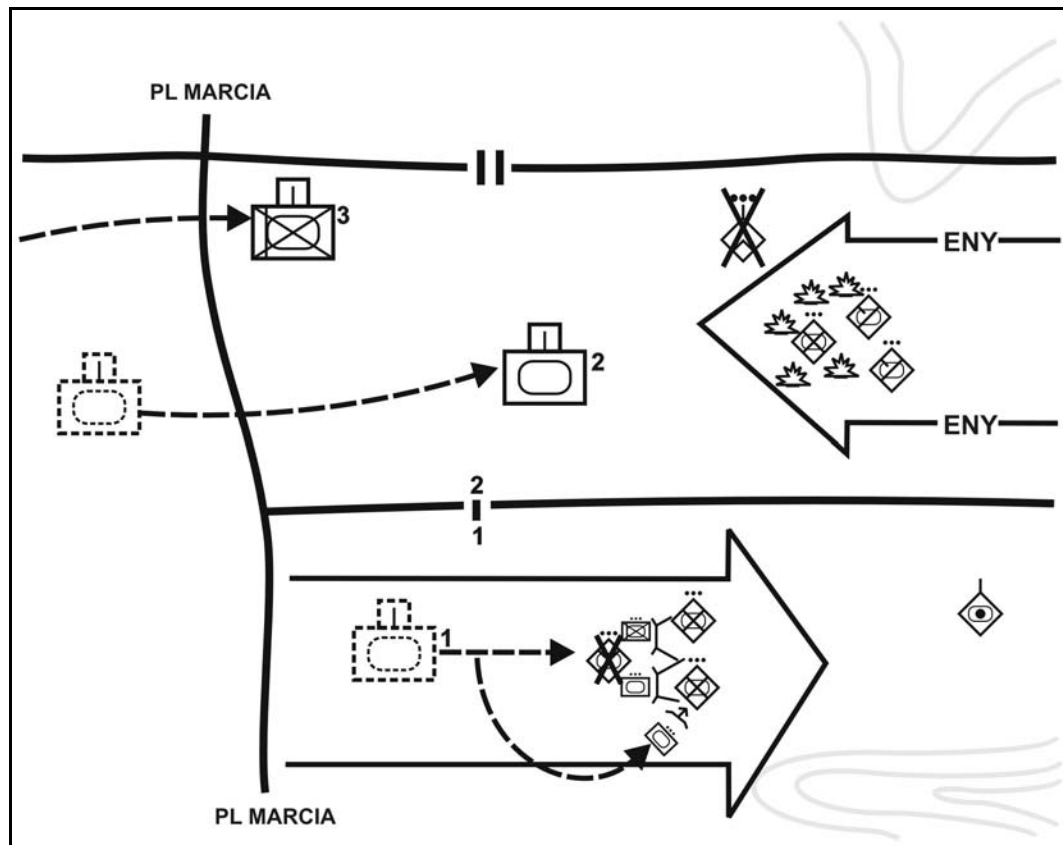


Figure 5-6. Frontal attack against a moving enemy.

## 5-9. SEQUENCE OF OFFENSIVE OPERATIONS

The commander and staff consider both preparation and execution as they plan an offensive mission.

a. **Preparation.** The TF conducts extensive reconnaissance of the objective to support the commander's decisions of how to employ his combat power against the enemy. He normally does not make final decisions as to the exact conduct of the operation until ISR operations develop the enemy situation. The commander and staff direct and supervise mission preparations to prepare the TF for the battle. The TF employs security forces to protect and conceal attack preparations from the enemy. Preparation time is also used to conduct precombat checks and inspections, rehearsals at all levels, and CSS activities.

b. **Execution.** Execution generally consists of the following four sequential events:

- Movement to the line of departure.
- Approach to the objective.
- Actions on the objective.
- Consolidation and reorganization.

The TF then prepares for follow-on missions as directed by higher headquarters.

(1) ***Movement to the Line of Departure.*** When attacking from positions not in contact, TFs often stage in rear assembly areas, road march to attack positions behind friendly units in contact with the enemy, conduct passage of lines, and begin the attack. (See Chapter 12, Section VI [Tactical Road Marches] and Section VII [Assembly Area Operations]). When attacking from positions in direct contact, the line of departure is the same as the line of contact.

(2) ***Approach to the Objective.*** The commander and staff plan the approach to the objective to ensure security, speed, and flexibility. They select routes, techniques, formations, and methods (air, mounted, dismounted) that best support actions on the objective. All leaders must recognize this portion of the battle as a fight, not a movement. The TF may have to fight through enemy combat forces, obstacles, artillery strikes, security elements, possible spoiling attacks, and other combat multipliers to reach the objective. The commander employs techniques that avoid the enemy's strength when possible and conceal the TF's true intentions. He tries to deceive the enemy as to the location of the main effort, uses surprise to take advantage of his initiative in determining the time and place of his attack, and uses indirect approaches when available to strike the enemy from a flank or the rear.

(3) ***Actions on the Objective.*** During an offensive operation, the TF's objective may be terrain- or force-oriented. Terrain-oriented objectives usually require the TF to seize or secure a designated area. However, to gain a terrain-oriented objective often requires fighting through enemy forces. If the objective is an enemy force, an objective area may be assigned for orientation, but the TF's effort is focused on the enemy's actual location. The enemy may be a stationary or moving force. Actions on the objective start when the TF begins echeloning its fires onto the objective. This action usually occurs with preparatory fires while the TF is still approaching the objective.

(4) ***Consolidation and Reorganization.*** The TF reorganizes and consolidates as required by the situation and mission. The consolidation and reorganization plan needs to be as detailed as the assault plan.

(a) *Consolidation*. Consolidation consists of actions taken to secure and strengthen the objective and defend against enemy counterattack. The unit providing the supporting effort during the assault may or may not join the assault force on the objective. Planning considerations should include unit locations, sectors of fire, forces oriented on enemy counterattack routes, and provisions to facilitate transition to follow-on operations.

(b) *Reorganization*. Normally conducted concurrently with consolidation, reorganization occurs as necessary to prepare the unit for follow-on operations. Detailed planning provides the task force a plan for evacuating and recovering casualties, recovering damaged equipment, providing for prisoners of war, and integrating replacement personnel.

(5) *Follow-On Missions*. The TF executes follow-on missions as directed by the higher commander. The most likely mission is to continue the attack. Other missions may include supporting a passage of lines for a follow-on force, defending, or participating in an exploitation or pursuit. The TF develops plans for follow-on missions based on the higher headquarters' plan, the higher commander's intent, and the anticipated situation.

## 5-10. MOVEMENT TECHNIQUES AND FORMATIONS

The selection of movement techniques and attack formations for the TF depends on the factors of METT-TC.

a. **Movement Techniques**. The movement techniques used are traveling, traveling overwatch, and bounding overwatch. The TF does not usually move as a unit using one movement technique. However, when moving as a unit along a single avenue, the TF commander designates the movement technique to be used by the lead unit(s) based on the likelihood of enemy contact. For example, the TF may be moving to contact in column formation while the lead company team may be in a wedge formation using traveling overwatch. Movement techniques are used when not in contact with the enemy; they end upon encountering any situation that requires an active or passive response to the enemy under the seven forms of contact (visual, physical, indirect, obstacles, aircraft, NBC conditions, or electronic warfare) when the unit begins its actions on contact and the overwatching force begins its suppressive fires (maneuver). The TF should try to make enemy contact with the smallest possible force. This technique allows the majority of the TF the freedom to maneuver against the enemy force.

b. **Formations**. The TF may move in any one of these basic formations: column, wedge, vee, echelon, and line. The TF may use more than one formation in a given movement, especially if the terrain changes during the movement. For example, the TF commander may elect to use the column formation during a passage of lines and then change to another formation, such as a wedge. Other factors, such as the distance of the move or enemy dispositions, may also prompt the commander to use more than one formation. Distances between units depend on the factors of METT-TC.

(1) **Column Formation**. The TF moves in column formation (Figure 5-7, page 5-16) when early contact is not expected and the objective is far away. The TF's lead element normally uses traveling overwatch while the following units travel. The column formation--

- Facilitates speed of movement, ease of control, and usefulness in close terrain.
- Provides for quick transition to other formations.

- Requires flank security.
- Provides the majority of firepower to flanks.

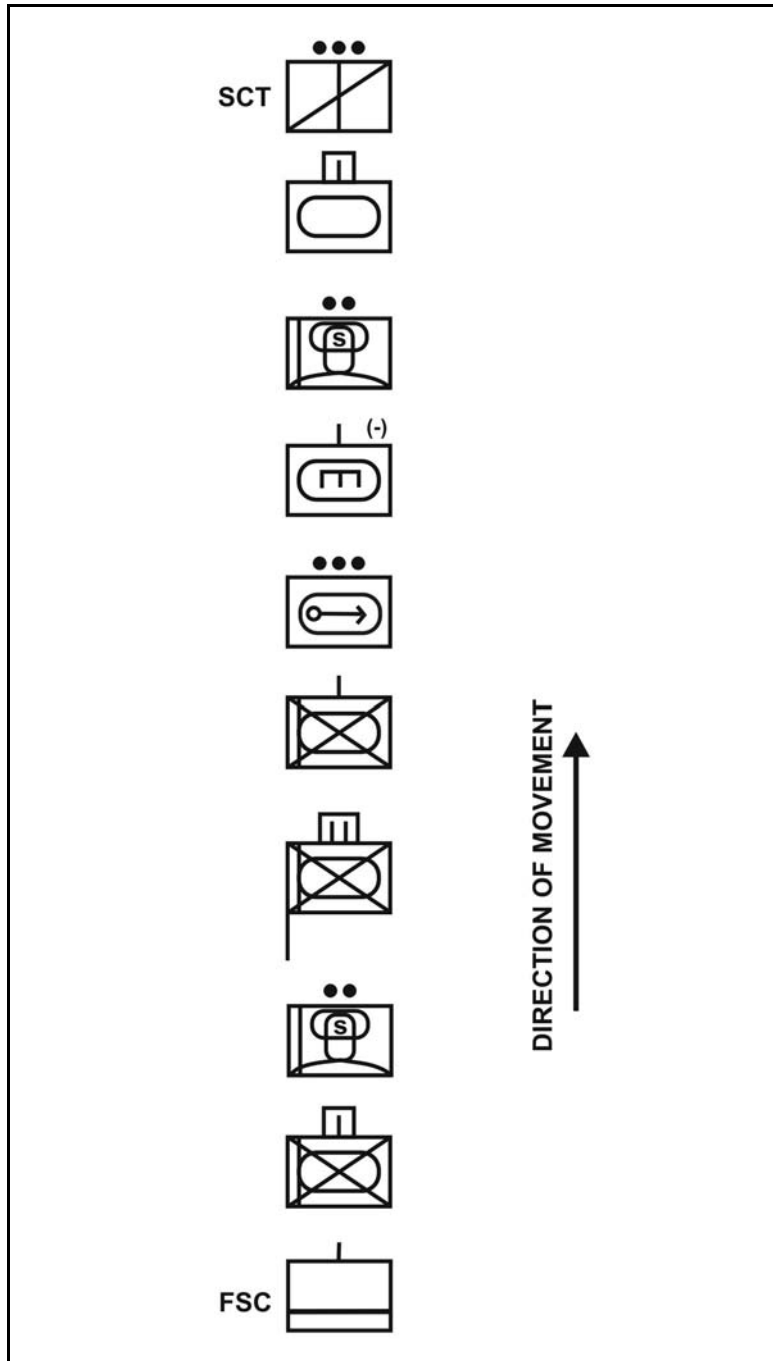
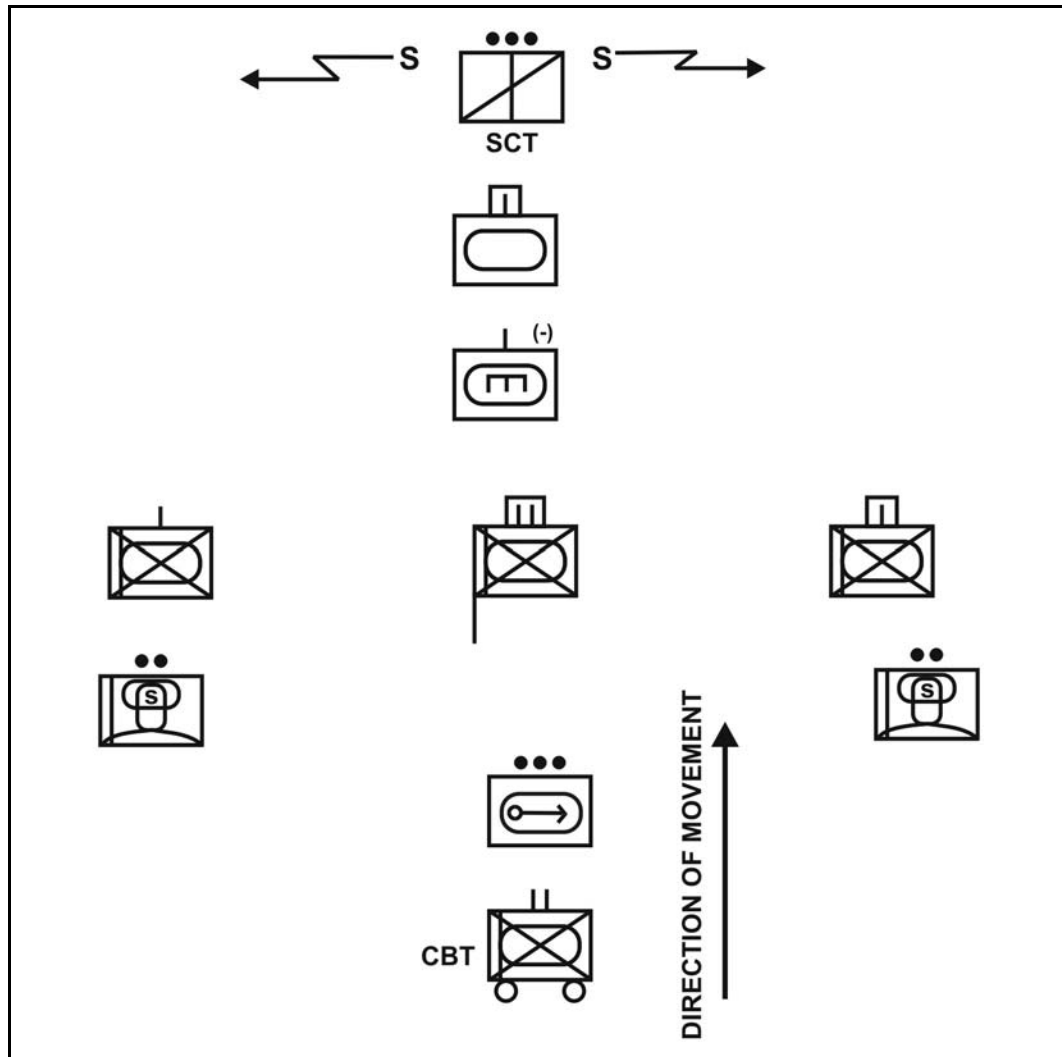


Figure 5-7. TF in column formation.

(2) **Wedge Formation.** The wedge formation (Figure 5-8) postures the TF for enemy contact on its front and flanks. The force uses the wedge when enemy contact is possible or expected but the location and disposition of the enemy is vague. When not expecting enemy contact, it may use the wedge to cross open terrain rapidly. The wedge formation--

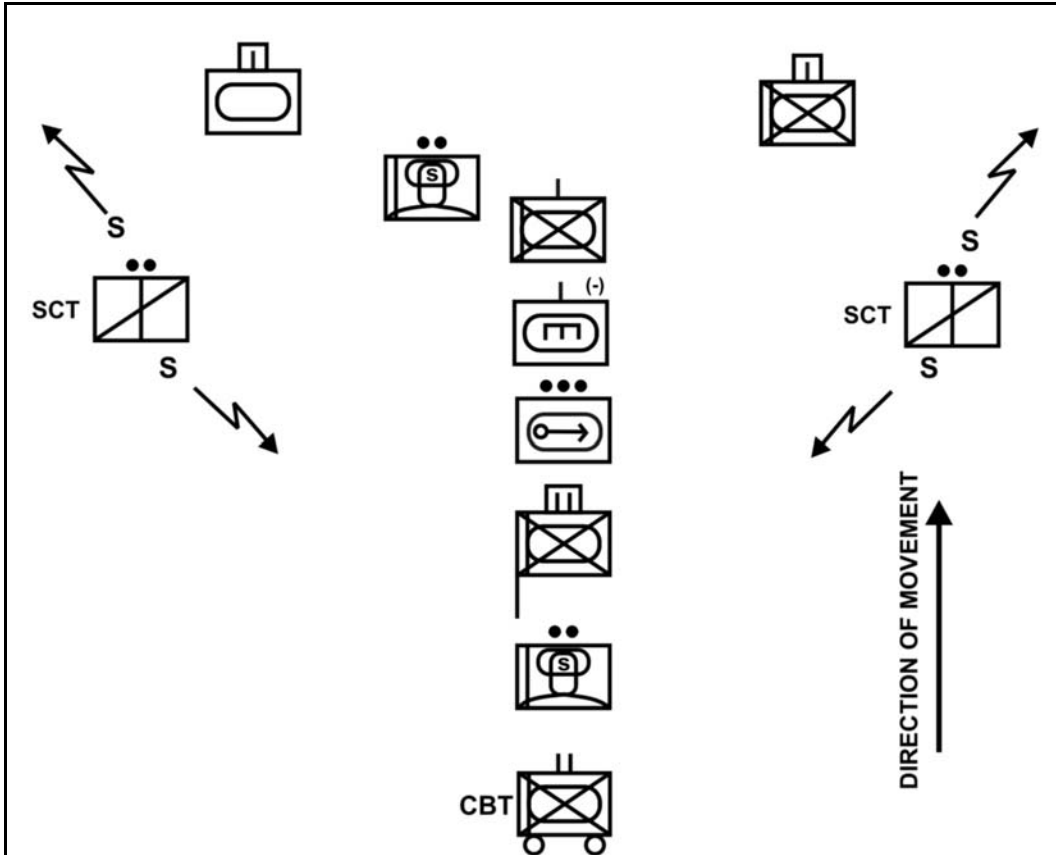
- Facilitates control and transition to the assault.
- Provides for maximum firepower forward and good firepower to the flanks.
- Requires sufficient space to disperse laterally and in depth.



**Figure 5-8. TF in wedge formation.**

(3) **Vee Formation.** The vee formation (Figure 5-9, page 5-18) postures the TF with two company teams abreast and one trailing. This arrangement is most suitable to advance against an enemy known to be to the front of the TF. The TF may use the vee when enemy contact is expected and the location and disposition of the enemy is known. The vee formation--

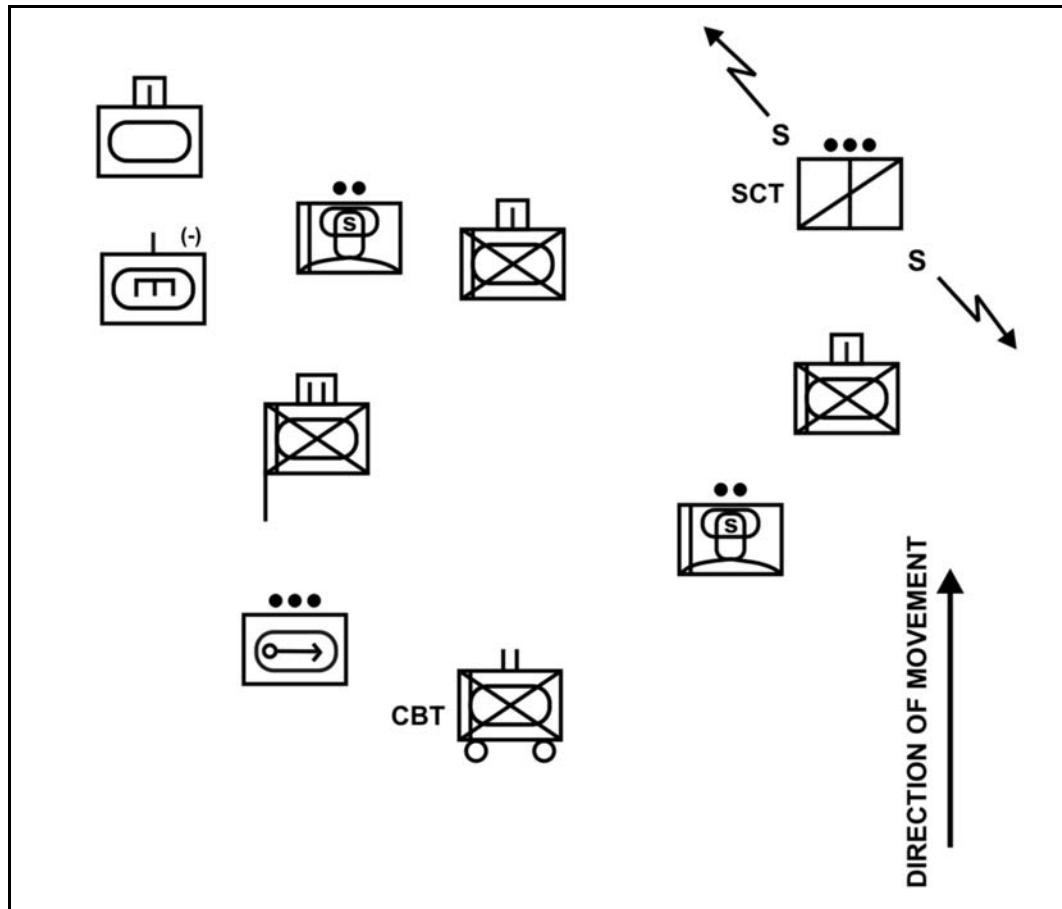
- Is hard to orient; control is more difficult in close or wooded terrain.
- Requires the TF to rely more on FBCB2 for control.
- Provides for good firepower forward and to the flanks.



**Figure 5-9. Task force in vee formation.**

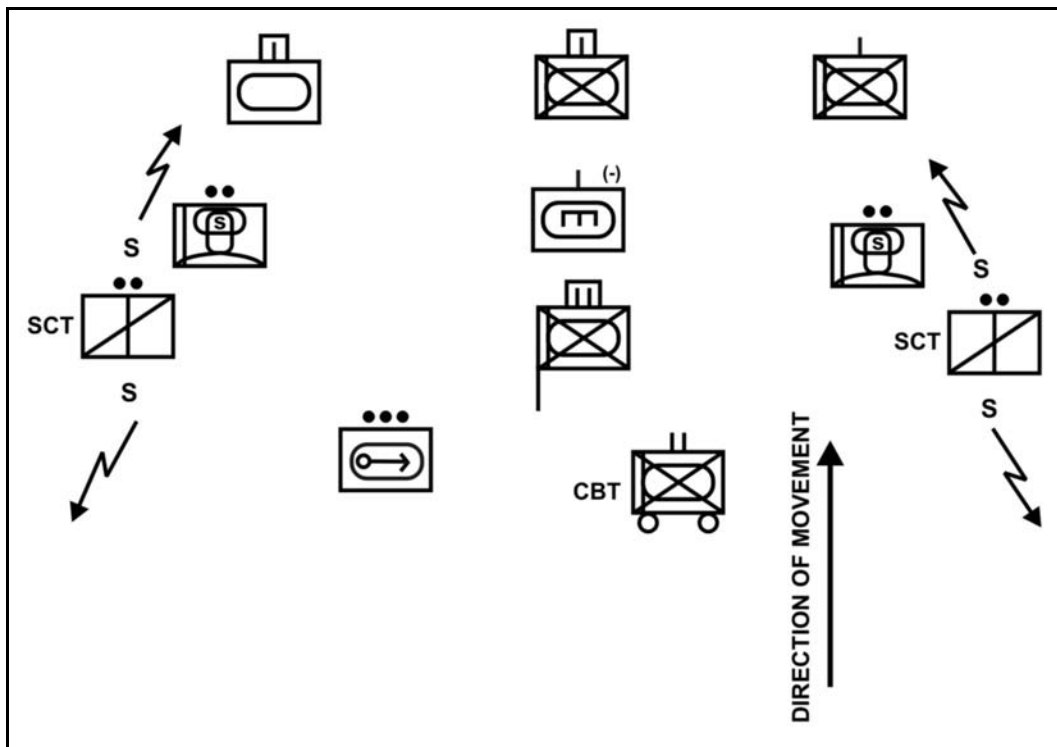
(4) ***Echelon Formation.*** The echelon formation (Figure 5-10) arranges the TF with the company teams in column formation in the direction of the echelon (right or left). The TF commonly uses the echelon when providing security to a larger moving force. The echelon formation--

- Provides for firepower forward and in the direction of the echelon.
- Facilitates control in open areas but makes it more difficult in heavily wooded areas.



**Figure 5-10. Task force in echelon right formation.**

(5) **Line Formation.** The line formation (Figure 5-11, page 5-20) postures the TF with company teams on-line and abreast of one another. Since it does not dispose company teams in depth, the line formation provides less flexibility of maneuver than other formations. The TF uses the line in an assault when it requires continuous movement with maximum firepower to the front.



**Figure 5-11. Task force in line formation.**

### **Section III. TYPES OF OFFENSIVE OPERATIONS**

At the battalion level, the offense takes the form of either a deliberate or a hasty operation, such as a movement to contact, attack, exploitation, or pursuit, across the full spectrum of conflict.

- **Hasty Operations.** The battalion conducts a hasty offensive operation after a successful defense or as part of a defense; as a result of a movement to contact, a meeting engagement, or a chance contact during a movement; or in a situation where the unit has the opportunity to attack vulnerable enemy forces.
- **Deliberate Operations.** A deliberate offensive operation is a fully synchronized operation that employs all available assets against the enemy's defense in accordance with (IAW) the ROE. Deliberate operations are characterized by detailed planning based on available information, thorough reconnaissance, preparation, and rehearsals.

The battalion may also be given the mission to conduct special-purpose attacks such as a raid, demonstration, spoiling attack, or counterattack. Attacks, exploitations, and pursuits may be conducted sequentially or simultaneously throughout the AO.

#### **5-11. MOVEMENT TO CONTACT**

The TF conducts movement to contact when the tactical situation is not clear or when the enemy has broken contact. Its purpose is to gain or reestablish contact with the enemy. TFs conduct movement to contact independently or as part of a larger force. The TF is normally given a movement to contact mission as the lead element of a brigade attack or as a counterattack element of a brigade or division (Figure 5-12). A properly executed



movement to contact develops the combat situation and maintains the commander's freedom of action after making contact. This flexibility is essential in maintaining the initiative. The movement to contact terminates with the occupation of an assigned objective or when enemy resistance requires the TF to deploy and conduct an attack to continue forward movement. The superior intelligence and acquisition capabilities available to the brigade and TF are likely to make movements to contact less common and change the nature of the meeting engagements that normally end a movement to contact. However, depending on the available intelligence assets, the effectiveness of the collection plan, and the enemy's success in masking his dispositions, the TF may still need to conduct a movement to contact. An exploitation or pursuit by the TF's parent brigade is likely to require a movement to contact by the TF, at least initially. A TF given a movement to contact mission is assigned an AO or an axis of advance and an objective at a depth to ensure contact with the enemy. The TF conducts movement to contact in a manner that allows it to maneuver to develop the situation fully, to maintain freedom of action, and, if possible, to defeat the enemy once contact is made.

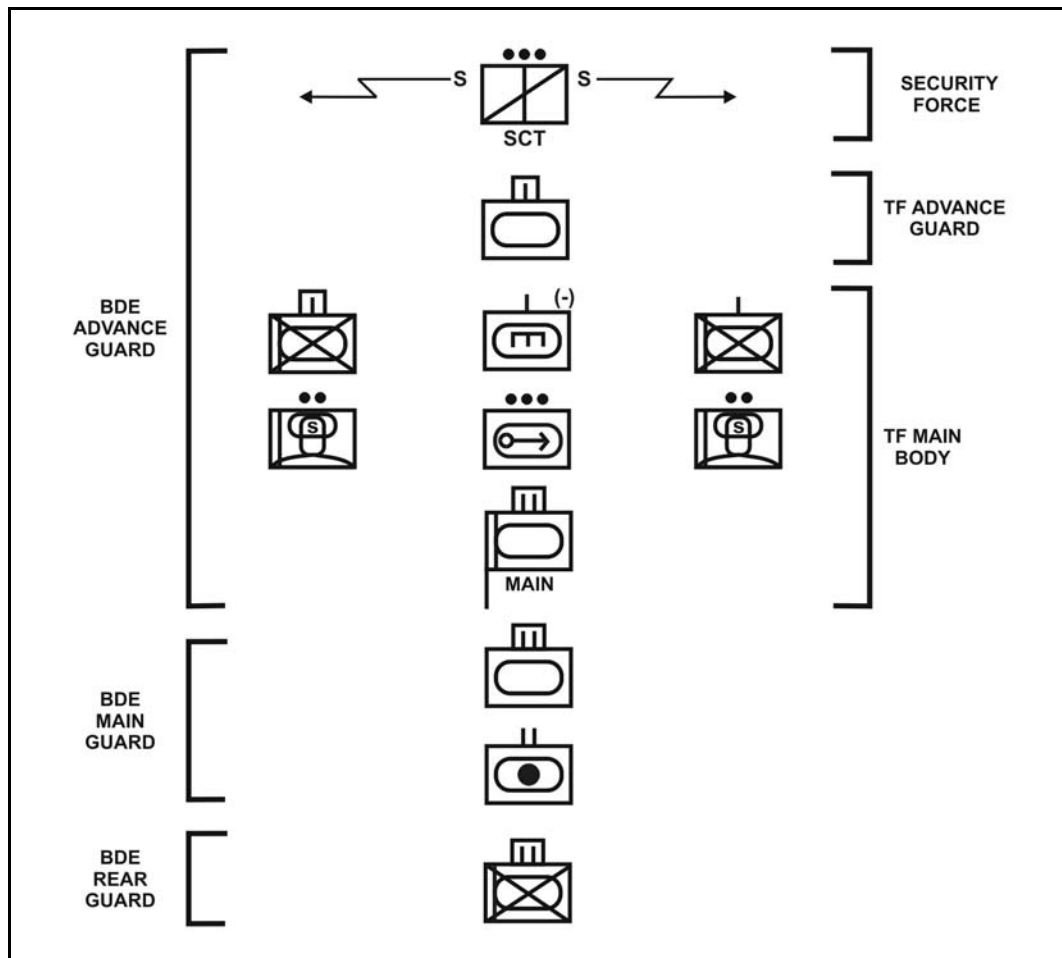
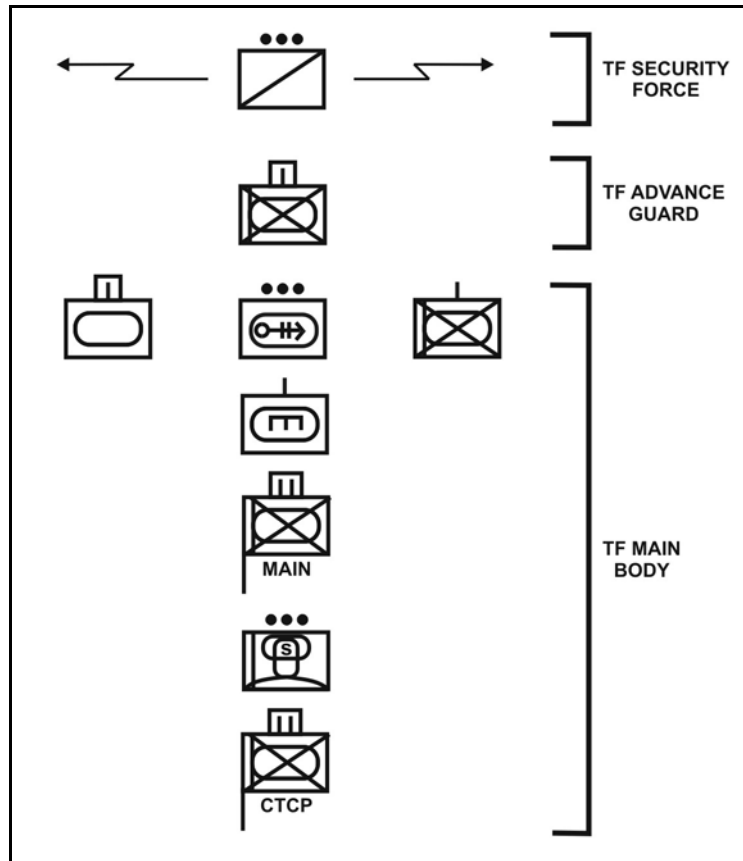


Figure 5-12. Task force movement to contact as part of a brigade.

### 5-12. APPROACH MARCH TECHNIQUE IN A MOVEMENT TO CONTACT

The TF normally organizes into a security force, an advanced guard, the main body, and flank and rear guards (Figure 5-13).



**Figure 5-13. Task force movement to contact**

a. **Security Forces.** The security force for the TF is normally the scout platoon. Engineers and forward observers (FOs) are attached to the security force as necessary. The security force normally has initial priority of indirect fires. The mission of the security force is to determine the size, activity, location, and depth of the enemy force. Other tasks include--

- Reconnaissance of routes, bridges, and roads.
- Reconnaissance of obstacles and restrictive terrain.
- Surveillance of NAIs.

(1) The security force must cover the frontage of the TF axis of advance. The TF avoids decisive engagement but, once it finds the enemy, it must keep him under surveillance and report his activity.

(2) The security force must be far enough ahead of the advance guard to provide adequate warning and sufficient space for them to maneuver. However, the security force must not be so far ahead that the advance guard cannot rapidly assist it in disengaging from the enemy should that become necessary. The advance guard keys its movement on the movement of the security force.

(3) The security force must be able to receive the latest information available from the brigade reconnaissance troop as well as information available from the brigade analysis control team (ACT) and other battlefield surveillance assets. With this information, the security force can confirm intelligence provided by these assets and greatly reduce the risks and unknowns normally associated with a movement to contact mission. This information is also available to the TF elements.

b. **Advance Guard.** The advance guard for a TF is usually a company team. Its composition depends on the factors of METT-TC. In open terrain, it may move mounted; in restricted, close, complex, or urban terrain, dismounted movement with vehicles in the overwatch is a better choice. The engineers follow or are attached to the lead elements. The two lead company teams are task-organized accordingly when a TF moves in parallel columns.

(1) The advance guard operates forward of the main body to provide security for the main body and ensure its uninterrupted advance. It protects the main body from surprise attack and develops the situation to protect the deployment of the main body when it is committed to action. The advance guard does this by rapidly developing the situation upon encountering the enemy's lead elements; destroying reconnaissance, ambushes, or delaying enemy forces; and marking bypasses for or reducing obstacles. The advance guard--

- Maintains combat information of the entire TF, especially the security force.
- Reports enemy contact to the TF commander.
- Collects and reports all information about the enemy.
- Selects tentative fighting positions for following TF units.
- Attempts to penetrate enemy security elements and reach or identify the enemy main force.
- Destroys or repels all enemy reconnaissance forces.
- Prevents enemy ground forces from engaging the main body with direct fires.
- Locates, bypasses, or breaches obstacles along the main body's axis of advance.
- Executes tactical tasks, such as fix, seize, or block, against enemy forces to develop the situation for the main body.
- Ensures that all pertinent information is passed to the rest of the TF via FBCB2 and FM voice.

(2) Until the main body is committed, the advance guard is the TF commander's main effort. Priority of fires shifts to the main body once committed.

(3) In planning the movement to contact, each contingency operation should revolve around the actions of the advance guard. The lead elements must be prepared to execute battle drills, especially those involving obstacle reduction and actions on contact.

c. **Main Body.** The main body keys its movement to the advance guard. It maintains information of the advance guard's activities via FM cross talk or its digital tools, primarily FBCB2 (when equipped). This digital capability allows the main body to key its movement on the advance guard while utilizing terrain and distance for force protection. The main body, remaining attuned to the advanced guard's situation, provides responsive support when the advance guard is committed.

(1) The main body contains the bulk of the TF's combat elements and is arrayed to achieve all-round security. The combat elements of the main body are prepared to deploy

and attack rapidly, giving them the flexibility to maneuver rapidly to a decisive point on the battlefield to destroy the enemy.

(2) The use of standard formations and battle drills allows the TF commander, based on the information available to him through ABCS, to shift combat power rapidly on the battlefield. Company teams employ the appropriate movement techniques within the TF formation. Company team commanders, based on their knowledge of the TF's situation, anticipate the TF commander's decisions for commitment of the main body and plan accordingly.

d. **Flank and Rear Security.** To provide flank security, platoon-size elements from one or more of the company teams in the main body provide a flank guard under company team control. These elements remain at a distance from the main body, which allows the TF time and space to maneuver to either flank. Flank security elements also operate far enough out to prevent the enemy from placing direct or observed indirect fires on the main body. Indirect fires are planned on major flank approaches to enhance security. One platoon pulled from the main body may provide security, but combat forces are not normally available to perform this mission. The TF attains rear security by rapid forward movement. This rapid movement forward gives the enemy less time to react or reposition forces to attack the TF.

### 5-13. INTEGRATION OF CS AND CSS ELEMENTS

The task force commander determines how to integrate and maximize the employment of his additional combat enablers while conducting MTC.

a. **Field Artillery.** Priority targets and FASCAM are allocated to the reconnaissance and security force and the advance guard. The brigade provides DS field artillery. The brigade positions field artillery units to provide continuous indirect fires for the moving TF. Given the brigade's emphasis on proactive counterfires and the likelihood for operating in close terrain, the TF must rely on its organic mortars.

b. **Mortars.** The TF mortars may be placed under the operational control of the advance guard, based on METT-TC, in order to provide responsive fires and smoke to support initial actions on contact.

c. **Air Force.** Close air support, if available, interdicts enemy counterattack forces or destroys defensive positions.

d. **Air Defense Artillery.** ADA assets generally provide area coverage for the TF and cover movement through restricted areas. However, some ADA assets may provide direct support for the advance guard. Regardless of the command relationship, ADA elements operate well forward on the battlefield.

e. **Engineers.** Priority of engineer support is to mobility. Elements of the supporting engineer unit may join the reconnaissance and security force to reconnoiter obstacles, based on METT-TC. Engineers may travel with the advance guard to assist in mobility of the advance guard and main body (Refer to Chapter 12 and FM 3-34.2 for detailed discussion of combined arms breaching operations). Situational obstacles are planned to support the security forces and the advance guard.

f. **Combat Service Support.** The object of CSS operations is to provide support as far forward as possible without disrupting operations. The priority is to move Class V forward and to evacuate casualties rearward. The FSB accomplishes its core functions through centralization of support, which provides the maneuver commander with

increased efficiency and effectiveness in the flow of support and supplies. Centralized support also allows the FSB commander to weight the battle logistically or surge as required. CSSCS and the near-real-time information provided by FBCB2 enhance centralization of support.

(1) In offensive operations, the FSC may push emergency resupply of Classes III and V forward to logistics release points as needed. The TF commander, XO, and S4 may determine that the mission requires additional support of Classes III and V, which can be pushed forward, uploaded, and positioned at the CTCP.

(2) Combat repair teams (CRTs) from the FSC are placed forward with each TF, usually down to the company/team. These teams are controlled by the company XO and first sergeant who communicate with the CTCP to ensure CRT activities are coordinated. The CRTs evacuate non-repairable equipment (due to time constraints or the lack of a required part) to the UMCP. UMCPs provide support to the CRTs as needed, and the CRTs evacuate equipment to the UCMP that can not be repaired within 24 hours. UCMP should locate on main axes or main supply routes. The S4 may request heavy equipment transport (HET) to assist in rearward evacuation.

(3) When developing CHS for offensive operations, it must be responsive to several essential characteristics. As operations achieve success, the areas of casualty density move away from the supporting medical treatment facility (MTF). This causes the routes of medical evacuation (MEDEVAC) to lengthen. The heaviest patient workloads occur during disruption of the enemy's main defenses, at terrain or tactical barriers, during the assault on final objectives, and during enemy counterattacks. The accurate prediction of these workload points by the HSS planner is essential if MEDEVAC operations are to be successful. As advancing combat formations extend control of the battle area, supporting medical elements have the opportunity to clear the battlefield. This facilitates the acquisition of the battle wounded and reduces the vital time lapse between injury and treatment.

(a) The battalion surgeon, assisted by the battalion PA, field medical assistant, and the platoon sergeant, is responsible for the HSS plan for the battalion. The foundation of the battalion HSS plan is the battalion commander's guidance and the brigade HSS plan. As operational requirements or the mission changes, the HSS plan must be updated. See FM 4-02.4 for information on planning HSS for the maneuver battalion, MDMP, COA, and medical troop-leading procedures.

(b) The TF has three ambulance squads consisting of two M113A3 ambulances per squad. The maneuver team 1SG has operational control of the squad(s). The TF commander may choose to locate three ambulances forward with the main effort while the remaining three ambulances support the other elements or await dispatch at the TF aid station at the CTCP. Treatment squads trail the main body or can conduct split-team operations. In the offense, the factors of METT-TC determine whether casualties are evacuated by ambulance to a casualty collection point or an ambulance exchange point. Medical personnel from the forward support medical company dispatch ambulances forward to the AXP to receive and evacuate casualties from the TF treatment squads.

(4) In offensive operations, it may be difficult to maintain lines of communication. Support elements must be prepared to quickly reposition in order to maintain continuous support to the task force.

## 5-14. PLANNING

Planning for movement to contact plan is flexible and promotes subordinate initiative. Planning begins by developing the concept of the operation with focus on ultimate control of the objective and conducting a reverse planning sequence from the objective to the line of departure (LD). This is accomplished by developing a simple scheme of maneuver, issuing a clear commander's intent, and developing plans to execute likely maneuver options that may occur during execution. Increased emphasis is placed on developing an aggressive and flexible reconnaissance effort that is linked to the commander's PIR, which is normally focused on locating and gathering information about the enemy's strength, disposition, and activities.

a. **ISR.** The first consideration for a movement to contact is ISR planning. The brigade plays a major role based on the assets available and its links to division and higher assets. The TF is one of several elements executing the brigade's ISR plan.

(1) The first priority is to determine anticipated enemy locations, strengths, and actions. Potential enemy mission, intent, objectives, defensive locations, use of key terrain, avenues of approach and routes, engagement areas, and obstacles are among the items that must be identified early and incorporated into the ISR plan. Because the brigade is filling information gaps and establishing conditions for gaining information dominance, this is a period of intense use of information systems. Intelligence information must be gathered, analyzed, fused, and shared on a timely basis with those who can act upon the information. This information, available through ASAS, must be distributed throughout the TF.

(2) Various elements within the TF conduct ISR operations.

(a) *Scout Platoon.* The scout platoon has the soldiers that are best trained to function as the "eyes and ears" for the TF and is the element that can be committed the quickest. Scouts are used in the hardest to cover areas and to link with the brigade reconnaissance troop. They are also used to confirm and identify enemy locations, orientations, and dispositions. They report their observations and significant changes in enemy activity before, during, and after the movement to contact.

(b) *Ground Surveillance Radar.* GSR detects moving vehicles and personnel in open terrain at long ranges and provides information on the number, location, disposition, and types of targets. Normally, GSR covers open, high-speed approaches where early detection is critical. GSR also monitors defiles and detects enemy reconnaissance elements using oblique shots across the TF's sector along open, flat areas. The integration of GSR allows the scout platoon to focus on complex, urban, close, and restrictive terrain.

(c) *Remote Sensors.* Remote sensors are assets that belong to units outside the TF, but they are frequently placed in DS of the TF. These assets must be emplaced and monitored with information going to the TF S2, who relays it to higher headquarters.

(d) *Individual Weapon Platforms.* Each weapon platform, especially during patrolling or while manning observation points, is a source of information that needs to be integrated into the overall intelligence-gathering effort. The sniper squad is trained and well equipped to man OPs in support of the ISR effort (see Appendix F, Sniper Employment).

(3) Rapid exchange of relevant information between the TF and the brigade is required. Intelligence-gathering actions result in information dominance and, once established, can convert the movement to contact into an attack.

b. **Maneuver.** The TF plan for a movement to contact should be flexible and promote subordinate initiative. Developing a simple scheme of maneuver, issuing a clear commander's intent, and developing plans to execute likely maneuver options that may occur during execution contribute to flexibility and subordinate initiative.

(1) In developing his concept, the commander anticipates where he is likely to meet the enemy and then determines how he intends to develop the situation that leads to an attack under favorable conditions (actions on contact). The commander must attempt to visualize this process during his mission analysis and take into account his active and passive responses to enemy contact. The commander focuses on determining the TF's organization and formation that best retains his freedom of action upon contact and supports his concept against known or anticipated enemy forces.

(2) The commander and his staff develop plans for the maneuver options of attack, report and bypass, defend, and retrograde based on the higher commander's intent and the situation. They define the conditions in terms of the enemy and friendly strengths and dispositions that are likely to trigger the execution of each maneuver option. They identify likely locations of engagements based on known or suspected enemy locations. The commander states the bypass criteria for the advance guard. He must recognize the loss of tempo created by fighting every small enemy force encountered with the lead element. The advance guard may attack small enemy forces that it can quickly destroy without losing momentum, but larger or more stubborn enemy forces are best bypassed and destroyed by the main body.

(3) Areas of likely contact, known enemy positions, and areas that are potentially dangerous to the TF (such as potential ambush locations, obstacles, and open areas) require close planning consideration. The staff must carefully plan actions for moving through these danger areas quickly and securely.

(4) The scheme of maneuver covers the TF's actions from LD to consolidation and reorganization. The scheme of maneuver paragraph should address--

- Task and purpose of subordinate elements.
- Actions at known or likely enemy contact locations.
- Scheme of fires.
- Direct fire and indirect fire control measures.
- CCIR.
- Methods for moving through and crossing dangerous areas.
- The TF's formation and known locations where the formation will change.
- Actions and array of forces at the final objective or LOA.
- DPs and criteria for execution of maneuver options that may develop during execution.

(5) The following fundamentals guide the development of the scheme of maneuver for a movement to contact.

(a) Focus all efforts on finding the enemy by developing a strong reconnaissance, surveillance, and target acquisition effort and through the employment of robust security forces.

(b) If at all possible, make contact with electronic means first. If that is not possible, then make contact with the smallest force possible, consistent with protecting the force.

(c) Make initial contact with small, mobile, self-contained forces to avoid decisive engagement of the main body. This procedure allows the commander maximum flexibility to develop the situation.

(d) Task-organize the force and use movement formations that enable the TF to deploy and attack rapidly in any direction.

(e) Maintain the ability to mass fires and effects rapidly in any direction.

(f) Keep forces within supporting distances to facilitate a flexible response.

(g) Maintain contact, once gained, regardless of the maneuver option adopted.

(h) Rely on SOPs and drills to develop the situation and maintain tempo. The key is swift massing of all available combat power against the enemy once contact is made.

(i) Develop a flexible scheme of maneuver since the location of the engagement with the enemy is not known. Flexibility is achieved by incorporating multiple DPs and triggers into the plan based upon where engagements are likely.

c. **Fire Support.** The following are key considerations for the fire support (FS) plan:

(1) Facilitate responsive and decentralized fires by a clear understanding of the essential fire support tasks for each phase of the operation, an understanding that is critical to the success of the FS plan. (See Appendix G , Fires Integration.) Once it makes contact, the TF shifts control of all available fires to the observer who is in the best position to control fires against the enemy.

(2) Plan targets based on known or suspected enemy locations and danger areas and to support future operations. Refine targets based on the reconnaissance effort as the operation progresses.

(3) Maximize the use of priority targets along the axis of advance. Plan triggers to put these targets into effect and cancel them based on the movement of the TF.

(4) Ensure immediately responsive fire support to the lead elements by assigning priority of fires to the ISR operations and or to the advance guard.

(5) Position observers effectively and maximize the use of lead maneuver forces to call for fires since they often have the best view of the enemy. Observers must understand the EFSTs for each phase of the operation.

(6) Synchronize the movement and positioning of artillery and mortars with the tempo of the TF and the FS requirements.

d. **Engineer Support.** The following are key considerations for the scheme of engineer operations:

(1) Task-organize engineer forces well forward to support potential breaching operations (Refer to Chapter 12 and FM 3-34.2 for detailed discussion of combined arms breaching operations).

(2) Use the advance guard, which is normally the priority for support, to task-organize with additional mobility assets and engineer forces.

(3) Ensure the reconnaissance plan integrates the collection of obstacle and terrain intelligence.

(4) Maintain the flexibility to mass engineers to breach complex obstacles.

(5) Plan obstacle belts, obstacle control measures, and situational obstacles to support flank security. Develop and adjust obstacle locations and triggers for execution based on the TF's movement and the enemy situation.

(6) Develop plans for the handover of marked obstacles, lanes, and bypasses.

(7) Consider the requirement for route maintenance, clearance, and repair.



e. **Air Defense Support.** The following are key considerations for the air defense plan.

(1) Use the information available to friendly forces to integrate ADA assets into the TF formation to provide all-round air defense protection. Normal priorities for protection are the main body and the advance guard.

(2) Shift and reposition ADA assets based on the TF's movement, selected maneuver option, and changes in the enemy air situation.

(3) Ensure adequate air defense of forces during movements through choke points, breach lanes, bridges, and restrictive terrain.

f. **Nuclear, Biological, Chemical Support.** The following are key considerations for NBC planning. (See also Appendix C.)

(1) Ensure the scout platoon is prepared for NBC reconnaissance tasks.

(2) Disseminate NBC threats, once detected, immediately throughout the brigade.

(3) Integrate and synchronize the use of smoke to support critical actions such as breaching or assaults. Ensure artillery and mortar smoke complement each other.

(4) Develop decontamination plans based on the commander's priorities and vulnerability analysis. Disseminate planned and active sites via FM or FBCB2.

g. **Combat Service Support.** The following are key considerations for the CSS plan.

(1) Continuously update the CSS plan based on near-real-time status of units. Ensure the CSS plan is responsive and flexible enough to support all maneuver options. Plan support from initiation of the operation to the final objective or LOA.

(2) Support the TF using the forward support company (FSC/HHC) for Class I, Class II, Class V, and maintenance and repair parts support.

(3) Integrate backup support from the forward support battalion to include deployment of a forward logistics element to provide Class III, Class V, HSS, and maintenance and repair parts to reinforce the support provided by the FSC/HHC.

(4) Weigh the risks that extended distances create for security of MSR and CSS assets based on the potential of undetected or bypassed enemy forces.

(5) Use all available assets to develop and maintain an accurate enemy picture behind the lead maneuver elements.

(6) Plan and rehearse for enemy contact.

(7) Plan and coordinate the locations, displacements, and routes of CSS assets to maintain responsive support.

(8) Plan and coordinate for aerial resupply.

h. **Preparation.** During preparation, the TF continues progress toward establishing information dominance. The primary concerns are that the TF commander and staff receive the latest information and that plans are updated to reflect the changes. The TF commander must ensure that his subordinates understand his concept and intent and their individual missions as new information becomes available. He normally uses backbriefs and rehearsals to ensure his intent is understood and all actions are integrated and synchronized. Simple, flexible plans that rely on SOPs and are rehearsed repetitively against various enemy conditions are essential to success.

i. **Inspections.** The commander inspects subordinate unit preparations to ensure they are consistent with his intent and concept of operations. He emphasizes subordinate plans to move through danger areas, conduct actions on contact, and transition into a

maneuver option. The commander ensures each subordinate force understands its assigned mission during the movement and its potential maneuver options that may develop during execution.

j. **Rehearsals.** The TF's leadership rehearses the plan against a wide range of likely enemy COAs that would cause the TF to execute various maneuver options at different times and locations. The goal of rehearsals is to prepare the TF's subordinate commanders for potential situations that may arise during execution and force them to make decisions under the anticipated conditions of the battle. This promotes flexibility and agility while reinforcing the commander's intent. The commander seeks to rehearse the operation from initiation to occupation of the final objective or LOA. Often, due to time constraints, the commander prioritizes the maneuver options and enemy COAs to be rehearsed based on the time available. The focus of the rehearsal is locating the enemy, developing the situation, executing a maneuver option, and exploiting success. The rehearsal must consider the potential of encountering stationary or moving enemy forces. Other actions to consider during rehearsals are--

- Actions to cross known danger areas.
- The advance guard making contact with a small enemy force.
- The advance guard making contact with a large force beyond its capabilities to defeat.
- The advance guard making contact with an obstacle the ISR force has not identified and reported.
- A flank security force making contact with a small force.
- A flank security force making contact with a large force beyond its capability to defeat.
- Actions to report and bypass an enemy force (based on the bypass criteria).
- Transition into a maneuver option.

k. **Reconnaissance.** The brigade and TF ISR effort, a key part of the execution, begins during preparation for the movement to contact. The primary focus of the ISR effort is to locate the enemy.

(1) **Locate the Enemy.** The brigade reconnaissance troop, supported by higher-level collection assets, seeks to locate the enemy well ahead of the brigade. This provides the brigade time to update plans, attack the enemy deep in the brigade's battlespace, select favorable terrain and positions for the direct fire engagement, position observers, and deploy prior to contact.

(a) When they detect enemy forces, reconnaissance and surveillance assets shift to determine the full extent of the enemy's strength and disposition. Reconnaissance assets gather vital intelligence on the enemy force and attempt to determine the enemy force's vulnerabilities, such as an exposed flank. The brigade hands over located enemy positions in the TF's area to the TF scout platoon. If the scout platoon encounters obstacles, it determines size, location, and composition and seeks bypasses. If it finds a bypass, the scouts assist in guiding following units to the bypass. If it cannot find a bypass, the scout platoon advises the commander on locations for a breach and assists in guiding forces to the breach site.

(b) The TF advance guard maintains contact with the TF scout platoon to coordinate combat actions and exchange relevant information. As the TF scout platoon locates enemy positions, it hands these locations off to the advance guard. In some cases,

elements of the TF scout platoon maintain contact with the enemy and guide the advance guard maneuver forces. Regardless of the technique used, these actions should be rehearsed and closely coordinated during execution to prevent fratricide and confusion.

(2) **Support the TF's Movement.** The task force scout platoon emphasizes terrain and obstacle reconnaissance primarily focused along the task force's axis of advance. The scout platoon seeks to identify and confirm restrictive terrain, trafficability of roads and routes, conditions of bridges, and locations of fording sites. The platoon also reconnoiters potentially dangerous areas such as obstacles, defiles, likely enemy positions, or possible ambush sites. If the TF scout platoon cannot clear these areas, the advance guard must assume a more deliberate movement technique.

(3) **Support Actions upon Contact.** Once an R&S element locates an enemy force, the TF continuously observes it. Reconnaissance assets assist friendly forces by guiding them along the best routes to engage the enemy. As contact develops, reconnaissance assets report enemy actions and battle damage assessment.

## 5-15. EXECUTION

The TF moves rapidly to maintain the advantage of an appropriate tempo. However, the commander must balance the need for speed with the requirement for security. This decision is based on the effectiveness of the ISR effort, friendly mobility, effects of terrain, and the enemy's capabilities. The situational understanding available within TF and subordinate company teams allows close tracking of the movement and location of the TF units. Location and movement of the security forces are continually monitored through voice reports or FBCB2 to ensure adequate security for the main body and to ensure the security forces are within supporting range of the main body, mortars, and artillery. The movement of CS and CSS units are controlled by their parent organizations, which adjust their movements to meet support requirements, avoid congestion of routes, and ensure responsiveness.

a. **Actions at Obstacles.** Obstacles pose a significant threat to the TF's momentum.

(1) Once a TF element detects an obstacle, it immediately distributes its location and description FM or digitally throughout the TF. The TF quickly seeks a secure and favorable bypass. If a bypass is available, the unit in contact with the obstacle exploits and marks the bypass; it also digitally distributes the bypass around the obstacle as soon as possible. Enemy forces normally overwatch obstacles. Units should approach all obstacles and restrictive terrain with the same diligence with which they approach a known enemy position.

(2) When the TF must breach, it takes the steps to execute the breaching fundamentals of suppress, obscure, secure, reduce, and assault (SOSRA) to create a breach lane and continue the movement to contact. Engineer forces from the main body support the breach effort by creating lanes, improving the marking of lanes, and guiding the main body through the obstacle.

b. **Destruction of Small Enemy Forces.** The TF destroys small enemy forces with a combination of indirect fires and maneuver.

(1) Depending on the commander's bypass criteria, the advance guard may fix small enemy forces identified by the reconnaissance and surveillance force. Once it fixes the enemy, the advance guard leaves a small combat force to contain the enemy until the main body can destroy it.

(2) The advance guard must provide the location of such a fixed enemy force to the TF S2 who then distributes the information to all units in the TF via FM or digital means. Detailed cross-talk between main body and fixing force commanders is critical to coordinate actions and avoid fratricide. The fixing force directs or guides the main body elements to the best location to attack the enemy force. Once the TF destroys the enemy, all forces quickly move to continue the advance.

c. **Report and Bypass.** When conducting a movement to contact as part of a larger force, the higher commander establishes bypass criteria that allow the TF to report and bypass enemy forces of a specific size.

(1) When an enemy force meets the criteria, the TF fixes the enemy force and leaves a small force to maintain contact while the remainder of the TF continues the advance. Once bypassed, the destruction of the enemy force becomes the responsibility of the TF's higher commander.

(2) Bypassed forces present a serious threat to forces that follow the maneuver elements, especially CSS elements. It is imperative that the bypassed enemy forces' locations and strengths be distributed throughout the TF to enable following units to move around these threats.

d. **Meeting Engagement.** A meeting engagement is a combat action that occurs when the TF, not completely deployed for battle, collides with and engages a sizable enemy force at an unexpected time and place. The enemy force may be moving or stationary. The goal, once in contact, is to maneuver quickly to overcome the enemy before he can react. This requires the commander to keep his force in a posture ready to react immediately to contact and develop the situation. Subordinate company teams must quickly react to contact, develop the situation, report, and gain a position of advantage over the enemy to give the TF time and space to act effectively. The TF's success depends on its subordinate units' ability to develop the situation effectively. The steps to do this follow.

(1) When initial contact is made, it must quickly determine the size and activity of the enemy force and avoid being fixed or destroyed. If possible, the force that makes initial contact avoids detection.

(2) If the enemy is moving, the force making initial contact determines the direction of movement and the size and composition of the force. The observers place fires on the lead enemy forces. Speed of decision and execution is critical when the enemy is moving.

(3) If the enemy is stationary, the force determines whether the enemy force is occupying prepared positions and whether they are reinforced by obstacles and minefields. The force attempts to identify antitank weapon positions, the enemy's flanks, and gaps in his positions.

(4) The advance guard moves quickly to overpower and destroy platoon-size and smaller security forces. Larger forces normally require deployment of the main body. The advance guard protects the main body by fixing enemy forces larger than platoon size, which allows the task force main body to retain its freedom to maneuver.

(5) In developing the situation, the advance guard commander maintains pressure on the enemy by fire and maneuver. He probes and conducts a vigorous reconnaissance of the enemy's flanks to determine the enemy's exact location, composition, and disposition. The advance guard immediately transmits this information to the TF commander.

(6) The TF commander uses this information to develop a plan of action by selecting a maneuver option from the several actions-on-contact options developed during planning.

e. **Maneuver Options.** Timely and accurate intelligence will facilitate the TF commander in his selection of the appropriate maneuver option. Normally, the commander makes the final decision for execution of a maneuver option based on the progress of the initial engagement of the advance guard. The movement to contact generally ends with the commitment of the main body. The following paragraphs provide a general description of the options that may develop after a movement to contact.

(1) **Bypass.** If rapid forward movement is required and the brigade commander has authorized bypass of enemy forces, the TF can bypass. If the size and mobility of the bypassed force represents a threat, the TF must fix or contain the enemy force until released by the brigade.

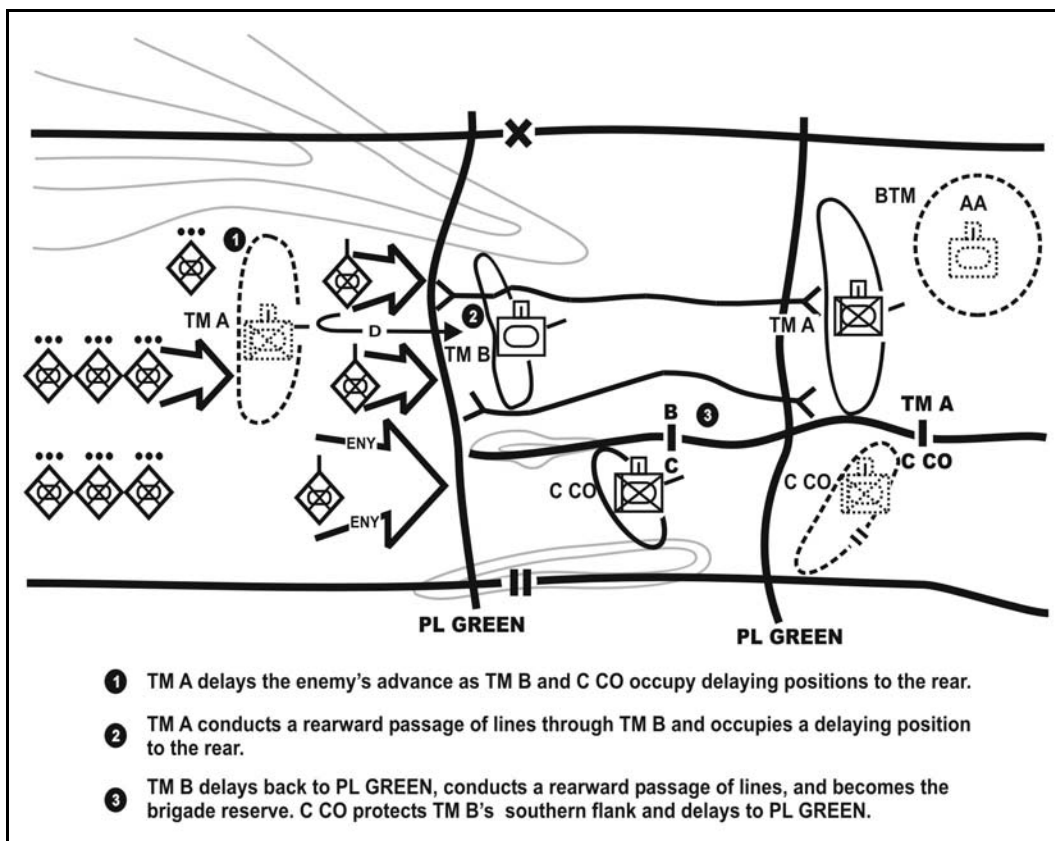
(2) **Hasty Ambush.** Ambush is effective against a moving or infiltrating force that is not aware of the presence of the TF. Instead of immediately engaging the enemy, the advance guard (and possibly the entire TF) moves into hasty attack-by-fire positions oriented on an engagement area. This option is enabled by the information available from FBCB2 (if equipped) and the speed and accuracy with which FRAGOs and other instructions can be passed. When most of the enemy is in the engagement area, the TF uses massed fires and maneuver to attack the enemy.

(3) **Attack.** The TF commander directs an attack when the TF has greater combat power than the enemy or when he assesses that the TF can reach a decisive outcome. The commander quickly develops a scheme of maneuver and concept of fires for the attack and digitally distributes orders to subordinate company teams. The commander employs fires, CAS, and situational obstacles. He controls the movement, deployment, and possible changes to the task organization of the TF forces. The envelopment is normally the most desirable form of maneuver and is used when there is sufficient maneuver space. The commander normally seeks to envelop the enemy force by fixing or blocking the bulk of the enemy force and then attacking a vulnerable flank. A penetration is normally used against a stationary enemy force that does not have an assailable flank, such as one in a perimeter defense. After a successful attack, the TF may continue the movement to contact or execute other missions as directed by the brigade commander.

(4) **Defend.** The TF commander directs a defense when the TF has insufficient combat power to attack or when the enemy's strength forces the TF to halt and prepare for a more deliberate operation. The TF maneuvers to the best available defensible terrain--either to the front or rear. The commander may direct the advance guard or another security force to delay an enemy attack to provide time for deployment of the task force. Company teams quickly deploy, establish security, array forces, and develop fire and obstacle plans. Special emphasis is placed on flank protection and adjacent unit coordination. As the enemy attacks, the commander repositions and maneuvers forces to defeat the enemy through massed fires, situational obstacles, and counterattacks. The commander seeks to defeat an attacking enemy force and create the opportunity for offensive action. In some cases, the TF may need to retain its position to allow the brigade commander time to commit additional forces.

(5) **Retrograde.** The TF commander directs a retrograde (Figure 5-14, page 5-34) when the TF lacks the combat power to attack or defend, improve a tactical situation, or

prevent a worse situation from developing. Lead elements of the TF establish initial defensive positions while nonessential CS and CSS assets reposition to the rear. Indirect fires, obstacles, and smoke are employed to assist forward elements with disengagement and displacement. Task forces in contact avoid becoming decisively engaged.



**Figure 5-14. Task force in retrograde.**

## 5-16. ATTACKS

An attack at the TF level is a type of offensive action characterized by close combat, direct fire, maneuver, and support from indirect fires. When the TF commander decides to attack, he must mass the effects of overwhelming combat power against a portion (or portions) of the enemy force or terrain with a tempo and intensity that the enemy cannot match. Information dominance enables the TF commander to choose the places where he wants to attack the enemy, places where the enemy is weak and least prepared for an attack and where the TF has the greatest opportunity for success. The following paragraphs discuss the tactics for conducting--

- A force-oriented attack against a stationary enemy force.
- A force-oriented attack against a moving enemy force.
- A terrain-oriented attack.

Attacks range along a continuum defined at one end by fragmentary orders (FRAGOs), which direct the rapid execution of battle drills by forces immediately available, and at the other end by detailed plans and orders. These attacks rely more on an implicit understanding than on electronic communication with detailed orders and appropriate

branches and sequels that make understanding explicit. At one extreme of the continuum, the battalion discovers the general enemy situation through a movement to contact and launches an attack as a continuation of the meeting engagement to exploit a temporary advantage in relative combat power and to preempt enemy actions. At the other extreme of the continuum, the battalion moves into an attack from a reserve position or assembly area with detailed knowledge of the enemy, a task organization designed specifically for the attack, and a fully rehearsed plan. Most attacks fall somewhere between the two ends of the continuum.

### **5-17. CHARACTERISTICS OF THE ATTACK**

As discussed earlier, the objective of an attack may be force- or terrain-oriented. A terrain-oriented objective requires the TF to seize or secure a designated geographical area. A force-oriented objective requires the TF to focus its efforts on a designated enemy force. The enemy force may be stationary or moving. All attacks depend on synchronization for success. They require planning, coordination via digital or analog means, and time to prepare.

a. By properly leveraging the digital systems and sensors, the TF commander and staff are able to obtain near-real-time knowledge of enemy composition, locations, activity, and probable intentions. The information systems available to the TF facilitate detailed planning, but the substance of sound planning depends on the abilities of a well-trained commander and staff. With the information available, the TF commander is better able to war-game and plan his actions against an enemy force from either stationary or moving C2 platforms. While the TF plans, the enemy will improve his defenses, disengage, or conduct spoiling attacks of his own. Clearly, planning must be accomplished in the shortest time possible and must accommodate changes based on what the enemy does.

b. The TF commander and his staff translate the assigned mission from the brigade into specific missions for subordinate company teams. The staff immediately forwards these missions, along with the appropriate portions of the brigade's plans and orders, digitally to subordinate company teams to facilitate parallel planning. Commanders at all levels work together to develop the best plans. This requires sharing information freely between the command posts. The goal is not just to reduce the time required to produce and distribute the plans; the real goal is to produce a better plan by including input from adjacent, higher, and lower elements. Additionally, this collaboration promotes buy-in and understanding of the plan, thereby enhancing preparation and execution.

### **5-18. FORCE-ORIENTED ATTACK AGAINST A STATIONARY ENEMY FORCE**

The TF may attack a stationary enemy force as part of a counterattack, spoiling attack, or as an initial attack against an enemy defense. The TF may also attack a stationary force as part of a brigade movement to contact or exploitation.

a. **Planning.** The focus of planning is to develop a fully synchronized plan that masses all available combat power against the enemy.

b. **Scheme of Maneuver.** The TF directs its main effort against an objective, ideally an enemy weakness, which will cause the collapse of the enemy defense. The TF seeks to

attack the enemy's flanks, rear, or supporting formations. By doing so, the TF retains the initiative and reduces its own vulnerabilities.

(1) The commander seeks to identify a poorly defended avenue of approach, a small unit lacking mutual support within the enemy defense, or a weak flank that he can exploit to gain a tactical advantage. When attacking a well-prepared enemy defense, the commander normally plans to isolate and then destroy small vulnerable portions of the enemy defense in sequence. The commander and staff develop the plan using a reverse planning process from actions on the objective back to the LD or assembly area. They incorporate plans for exploiting success and opportunities that may develop during execution. They emphasize synchronization of mounted and dismounted movement, maneuver, fires, and support throughout the attack.

(2) The commander and staff must consider the enemy's strength and obstacles to determine when and where the TF may need breaching operations. The size of the enemy force overwatching the obstacle drives the type of breach the TF conducts and whether the TF can conduct a successful breaching operation. The commander and staff consider the enemy's ability to mass combat power, reposition his forces, or commit his reserve. The TF then develops a scheme of maneuver to mass sufficient combat power at an enemy weakness. The location selected for breaching and penetration depends largely on a weakness in the enemy's defense where its covering fires are limited.

(3) The reverse planning process is an essential tool in building an effective plan to attack a defending enemy. By starting with actions on the objective and working back to the line of departure, the staff can allocate combat power, mobility assets, and indirect fires (suppression and obscuration).

c. **Fire Support.** The following are considerations for the FS plan:

(1) Position fire support assets to support the reconnaissance effort.

(2) Use deception fires to deceive the enemy as to the location of the main effort.

(3) Plan suppressive and obscuration fires at the point of penetration.

(4) Plan suppressive and obscuration fires in support of breaching operations.

(5) Plan fires in support of the approach to the objective. These fires engage enemy security forces, destroy bypassed enemy forces, and screen friendly movement.

(6) Synchronize fires on the objective to achieve the effects of suppress, neutralize, and destroy critical enemy forces that can most affect the TF's closure on the objective.

(7) Plan fires beyond the objective to support an attack or defense.

(8) Use indirect fires and CAS to delay or neutralize repositioning enemy forces and reserves.

(9) Plan locations of critical friendly zones (CFZs) to protect critical actions and HVT's, such as support forces, breaching efforts, and artillery assets.

d. **Engineer Support.** Maintaining the mobility of the TF in offensive operations is critical. The TF engineer must plan and allocate mobility resources to the security force, advance guard, and main body. The security force has just enough mobility resources to cover its own movement and to complete the reconnaissance mission. The advance guard needs enough resources to conduct breaching operations, such as opening lanes through obstacles for the main body to pass. (Refer to Chapter 12 and FM 3-34.2 for a detailed discussion of combined arms breaching operations.) If the obstacle is complex or covered by a relatively larger force, the main body deploys to conduct a breaching operation. Engineer task organization is based on supporting the TF breaching operations with



minimal engineer assets under TF control to transition to a TF breach in support of a deliberate attack, if needed. The TF uses situational obstacles to attack an enemy's vulnerability or specific course of action and can use situational obstacles to help secure the TF flanks. The following are considerations for the scheme of engineer operations.

(1) Plan for adjustment of the breach location based on the latest obstacle intelligence.

(2) Ensure information on obstacles receives immediate TF-wide dissemination including supporting CS and CSS platforms and units.

(3) Ensure digital topographic support system (DTSS) products are available and distributed on point of penetration, planned breach locations, and possible bypasses.

(4) Ensure adequate mobility support is task-organized well forward during the approach to the objective to support breaching requirements for complex obstacles.

(5) Mass engineers to support breaching operations.

(6) Support assaulting forces with engineers to breach enemy protective obstacles.

(7) Ensure adequate guides, traffic control, and lane improvements to support movement of follow-on forces and CSS traffic.

(8) Use situational obstacles for flank security.

e. **Air Defense Support.** In offensive operations, air defense units move to the position from which they can best protect the TF. The enemy uses helicopters primarily against armored forces. The Bradley Stinger fighting vehicle (BSFV) or Linebacker platoon normally provides direct support coverage to the TF. Priorities for protection may include company teams, fire support, engineer elements, command and control nodes, and logistics assets. ADA coverage is increased in areas and activities most vulnerable to air attack such as breaching operations or movements through restrictive terrain.

f. **Nuclear, Biological, Chemical Support.** The following are considerations for NBC.

(1) The reconnaissance platoon should be prepared for NBC reconnaissance tasks.

(2) Disseminate any detected NBC threats throughout the TF immediately via FBCB2 and FM voice.

(3) Integrate and synchronize the use of smoke to support critical actions such as breaching or assaults. Ensure artillery, mortar, and mechanical smoke are complementary.

(4) Develop decontamination plans based on the commander's priorities and vulnerability analysis. Disseminate planned and active decontamination sites via FBCB2.

g. **Combat Service Support.** The following are considerations for the CSS plan.

(1) Integrate the movement and positioning of CSS assets with the scheme of maneuver to ensure immediate support of anticipated requirements.

(2) Ensure adequate CSS support to the reconnaissance and surveillance effort. The S4 must plan well and integrate timely resupply and evacuation support of forward reconnaissance and surveillance assets into the ISR plan. He focuses on medical evacuation, especially air evacuation.

(3) Plan immediate support to high-risk operations such as breaching or assaults through the forward positioning of support assets.

(4) Plan for reorganization on or near the objective once the TF secures the objective. Articulate clear priorities of support during reorganization.

h. **Preparation.** The TF uses available time prior to the attack to conduct extensive reconnaissance, precombat checks and inspections, and rehearsals while concealing attack preparations from the enemy. The commander and staff refine the plan based on continuously updated intelligence. They use digital tools to allow subordinate company teams maximum time to prepare. Subordinates conduct parallel planning and start their preparation for the attack immediately after the TF issues a FRAGO. As more intelligence becomes available, the TF commander revises orders and distributes them via FM or FBCB2 when available, thereby giving subordinates more time to prepare for the attack. Regardless of the time available, the commander must conduct detailed planning and supervision of subordinate preparations.

i. **Inspections.** The commander supervises subordinate troop-leading procedures to ensure planning and preparations are on track and consistent with his intent. The commander may inspect subordinate unit order briefs and rehearsals. He focuses his inspections on the main effort and critical events such as assaults, breaching operations, and passages of lines. Since the commander cannot be everywhere at once, he maximizes the use of other key leaders and technology to assist him. Subordinate orders, provided digitally (when possible) back to the TF staff, allow the staff to check for congruence with the TF plans.

j. **Rehearsals.** The TF usually conducts rehearsals, but the type and technique may vary based on time available. During the combined arms rehearsal, the TF S2 portrays a thinking, uncooperative enemy with emphasis on enemy repositioning, employment of fires, and commitment of reserves. The primary focus of the rehearsal is actions on the objective. Each subordinate commander addresses the conduct of his mission as the rehearsal progresses. The rehearsal places special emphasis on timing of actions and the coordinated maneuver of forces. All subordinate commanders must accurately portray how long it takes to complete assigned tasks and how much space is required by their force. Direct and indirect fire plans are covered in great detail, to include the massing, distribution, shifting, lifting, and control of fires. The commander ensures subordinate plans are coordinated and consistent with his intent. The rehearsal also covers the following:

- Plans to execute follow-on missions or exploit success.
- Likely times and locations where a reserve is needed.
- Execution of the FS plan, to include shifting of fires, employment of CAS, adjusting of FSCMs, and positioning of observers.
- Breaching operations.
- Passages of lines.
- Contingency plans for actions against enemy counterattacks, repositioning, commitment of reserves, or use of NBC capabilities.
- Consolidation and reorganization.
- Execution of branches or sequels assigned by brigade.
- Execution of the CSS plan, to include UMCP, CASEVAC, movement of combat trains, and emergency resupply usage and movement.

k. **Reconnaissance.** Effective and current intelligence is a prerequisite for a successful attack.

(1) Before mounting an attack, the commander needs to determine the enemy's strength and disposition. In an attack, the entire intelligence collection, analysis, and

dissemination process must rapidly respond to the commander's critical information requirements. The brigade provides most of the information available to the TF commander and staff through FM updates or ASAS, when equipped. The commander must receive an accurate picture of the enemy's defense so he can decide on a COA and act faster than the enemy can react.

(2) When preparing for an attack, the commander and staff participate in development of the brigade's ISR plan. This is a well-resourced and coordinated reconnaissance effort that provides a detailed picture of the enemy situation prior to execution of the attack. This reconnaissance effort must include redundant information-gathering systems to ensure continuous flow of information to the brigade and, correspondingly, from the brigade to the TFs. The TF commander uses this intelligence to decide on a COA and make refinements to the plan. The ISR effort also provides him continuous updates during the attack so he can adjust execution of the operation based on the enemy's reactions.

1. **Enemy's Current Array of Forces.** The intelligence available to the TF comes from a continuous stream of information that begins with ISR systems, such as joint surveillance target attack radar system (JSTARS), UAVs, TF scouts, and the BRT, to establish the intelligence links to the TF.

(1) The first priority is to confirm information available on the enemy's composition, disposition, capabilities, and most probable course of action. The next priorities are the effects of weather and terrain and how the enemy is likely to fight. The S2 attempts to identify what the enemy will do and what information the TF needs to confirm the enemy's action. The TF ISR effort focuses on identifying indicators required for confirming the enemy's actual COA. This information is vital for developing and refining plans. Ideally, the TF does not make final decisions on how to execute the attack until it can identify the current array of enemy forces. Key areas to identify for a defending enemy force include--

- Composition, disposition, and capabilities of enemy forces along a flank or at an area selected for penetration.
- Composition, disposition, and capabilities of security forces.
- Location, orientation, type, depth, and composition of obstacles.
- Locations of secure bypasses around obstacles.
- Composition, disposition, and capabilities of defending combat formations within the enemy's MBA.
- Composition, disposition, capabilities, and location of reserves.
- Location of routes the enemy may use to counterattack or reinforce his defense.
- Types of enemy fortifications and survivability efforts.

(2) Reconnaissance forces patrol to gain intelligence. As time permits, reconnaissance assets observe the enemy defense from advantageous positions (OPs) to locate gaps, identify weapons systems and fighting positions, view rehearsals and positioning, and determine the enemy's security activities and times of decreased readiness. The S2 must discern any enemy deception efforts such as phony obstacles, dummy emplacements, and deception positions designed to confuse an attacker.

m. **Enemy Engagement Areas.** The TF commander, supported by the S2, seeks to define the limits of the enemy engagement areas. This includes locations where the

enemy can mass fires, weapon ranges, direct fire integration with obstacles, ability to shift fires, and mutual support between positions. This analysis requires effective terrain analysis, confirmed locations of enemy weapons systems (by system type), and a good understanding of the enemy's tactics. Reconnaissance forces report locations, orientation, and composition of defending weapons systems and obstacles. The analysis of the enemy's direct and indirect fire and obstacle plan assists the commander in determining when the TF must deploy, how to time and use indirect fires, how to avoid maneuvering inside the enemy's EA, and how feasible his scheme of maneuver is. The use of long-range indirect fires allows the commander to shape what the enemy can do relative to engagement areas. Key to such actions is the emplacement of complex obstacles.

n. **Enemy's Vulnerabilities.** The intelligence system and ISR effort also seek to identify enemy vulnerabilities, which may include--

- Gaps in the enemy's defense.
- Exposed or weak flanks.
- Enemy units that lack mutual support.
- Unobserved or weakly defended avenues of approach to the enemy's flank or rear.
- Covered and concealed routes that allow the TF to close on the enemy.
- Weak obstacles or fortifications in an enemy defense, especially along a flank.

o. **Support on the Approach to the Objective.** Reconnaissance elements initially focus on the enemy's security forces forward of his main defense to locate his positions and obstacles along the TF's planned routes of advance. Reconnaissance forces also locate gaps and routes that allow them to infiltrate into the enemy main defensive area or rear area. The ISR effort seeks to locate enemy forces that may reposition and affect the TF's approach to the enemy's main defense. Successful attacks depend on reconnaissance forces' directing indirect fires on targets in the enemy's rear that isolate the enemy's front-line forces and prevent them from being reinforced. A rapid, secure advance to the enemy's main defense depends on the reconnaissance effort's locating enemy security forces and obstacles.

p. **Execution.** The TF commander positions ISR assets to maintain observation of enemy reactions to the TF's maneuver on the objective. Reconnaissance assets focus on areas that the enemy will likely use to reposition forces, commit reserves, and counterattack. As the engagement on the objective develops, reconnaissance forces report enemy reactions, repositioning, and BDA. Again, reconnaissance elements target and engage enemy repositioning forces, reserves, counterattacking forces, and other high-payoff targets with indirect fires. Early identification of enemy reactions is essential for the TF's ability to maintain the momentum and initiative during the attack.

(1) **Approach to the Objective.** During the approach, the TF is ready to--

- Bypass or breach obstacles.
- React to artillery, chemical strikes, air attack, and electronic warfare (EW).
- Transition to different formations based on the terrain and enemy situation.
- Employ forces to screen or guard flanks that may become exposed or threatened during the approach.
- Avoid terrain features that are likely enemy artillery reference points, locations for chemical strikes, or locations for situational obstacles.

- Destroy or force the withdrawal of opposing enemy security forces.
- Minimize the effects of enemy deception.

(a) When the situation permits, a defending enemy generally establishes a security and disruption area around his forces to provide early warning of an attack, deny friendly reconnaissance, and disrupt the friendly force's attack. The strength of the enemy's security area depends on the time available, forces available, and his doctrine or pattern of operations. The TF must counter the effects of enemy security forces to ensure an unimpeded and concealed approach. Before the attack, reconnaissance forces seek to locate enemy security forces. Once located, the commander has the following options available:

- Destroy them immediately with indirect fires and CAS (preferred option).
- Destroy them with indirect fires and CAS during the approach to the objective.
- Conduct limited objective attacks prior to execution of the main attack.
- Employ a strong advance guard to destroy or force the withdrawal of enemy security forces during the approach to the objective.

(b) The TF must maintain a steady, controlled movement. Speed and dispersion, facilitated by close coordination and communication, are the norm with massing of weapons' effects to destroy the enemy's defense. If the formation is too slow or becomes too concentrated, it is vulnerable to massed enemy fires.

(2) **Actions on the Objective.** The TF commander maneuvers combat forces and employs fires, situational obstacles, and smoke to create favorable conditions for decisive maneuver against the enemy. The commander commits maneuver forces and fires to isolate, then rupture, a small vulnerable portion of the enemy's defense to gain a flank or create a penetration. The TF achieves final destruction of the enemy force through the attack of assaulting forces.

(3) **Fires.** The TF employs fires to weaken the enemy's position and set the conditions for success prior to closure within direct fire range of the enemy.

(a) Initially, preparatory fires focus on the destruction of key enemy forces that can most affect the scheme of maneuver. For example, during an attack to penetrate an enemy defense, the initial focus of preparatory fires is to destroy the enemy positions at the selected point of penetration. Preparatory fires may also--

- Weaken or neutralize enemy reserves.
- Emplace artillery-delivered situational obstacles to block enemy reserve routes into the objective.
- Deceive the enemy as to the TF's actual intentions.
- Destroy enemy security forces.
- Obscure friendly movements and deployment.

(b) The coordination between fires and maneuver is critical. As maneuver forces approach the enemy defense, the commander shifts fires and smoke to suppress and obscure the enemy. Proper timing and adjustment of fires enable a secure closure by the maneuver force on the enemy's positions. The COP provides maneuver force locations and allows their movement to be timed so that they can rapidly close on the enemy's position with minimum exposure to enemy fires. The commander must monitor the success of the preparatory fires to determine whether adequate conditions exist for commitment of the force. Reconnaissance elements provide battle damage assessment

(BDA) to the commander to assist him in making this decision. The commander may need to adjust the speed of the task force's approach to the objective.

(4) **Fix.** The TF can fix the bulk of the enemy forces into given positions or pursue a COA that limits the options available to the enemy.

(a) In limiting the options available to the enemy, the objective is to reduce the uncertainty during the battle. The primary goal is to isolate the unit targeted for destruction by preventing the enemy from laterally repositioning or reinforcing it.

(b) A company team normally fixes the enemy force by attacking an objective(s) that isolates a portion of the enemy's defense. In open terrain, the most common task for the supporting force is to fix the enemy with direct and indirect fire. In more complex terrain, the supporting force may need to seize terrain or destroy key enemy forces in limited objective attacks. Demonstrations and feints may also fix the enemy. The use of fires and CAS is vital in attacking enemy forces and reserves in depth to prevent their commitment against the TF.

(c) Before commitment, forces remain dispersed and outside the enemy's direct fire range, and they avoid exposing themselves to enemy observation. Forces not yet committed use this time to conduct final preparations and make adjustments to their plans. A key action during this time is the update of intelligence on enemy locations and conditions. The S2 should have an updated intelligence summary available just prior to the TF's crossing the LD. The commander uses assault positions, phase lines, terrain index reference system (TIRS), or checkpoints to control the positioning of the forces not yet committed. Commanders throughout the TF continuously assess the situation. Subordinate commanders anticipate decisions by the TF commander based on tactical information received. The commander commits subordinate forces when the desired levels of enemy suppression, destruction, and obscuration are achieved. Timely reporting, cross-talk, accurate assessments, and sharing of information by subordinate commanders are paramount.

(5) **Decisive Maneuver.** The attacker must be agile enough to concentrate his forces and mass his combat power by decisive maneuver before the enemy can reorient his defense.

(a) Normally, the destruction of a defending enemy force dictates an assault of the objective. The supporting force shifts direct and indirect fires and repositions as required to support the maneuver of assaulting forces. As the assaulting force is committed, the TF commander and staff ensure that current information is available on the following:

- Locations and types of enemy contact on the objective.
- Locations of reconnaissance forces.
- Locations of lanes and obstacles to include lane markings.
- Recognition signals and guides.
- Specific routes to use for the approach.
- Locations and orientations of fires from friendly forces.
- Additions or modifications of graphic control measures.

(b) The previously dispersed assaulting force(s) quickly assembles into combat formations and rapidly maneuvers to destroy the enemy forces and clear assigned objectives. The assaulting force(s) moves along covered and concealed routes to an exposed enemy flank, created penetration, or other position of advantage. Smoke assists with concealing the movement of assaulting forces. The assault includes destruction of

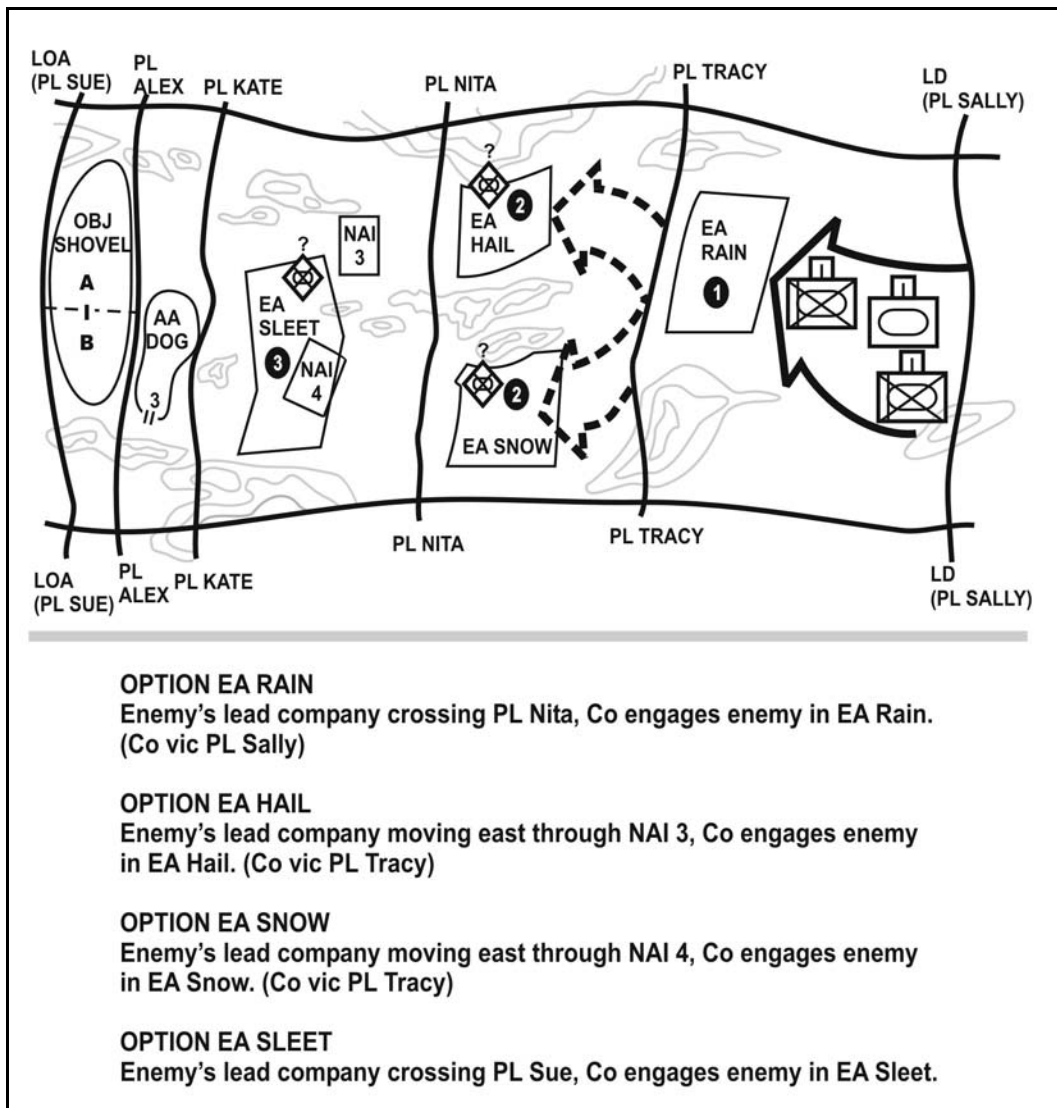
defending forces and clearance of trenches and fortifications and may involve a combination of mounted and dismounted movement. The commander's main focus is maintaining the momentum and security of the assaulting force(s). The ISR effort continues to report enemy repositioning, BDA, and enemy counteractions to the assault. The TF limits enemy repositioning and massing against assaulting forces through intense supporting fires and CAS, a rapid assault, and employment of smoke.

#### **5-19. FORCE-ORIENTED ATTACK AGAINST A MOVING ENEMY FORCE**

The TF is likely to attack a moving enemy force, especially during a counterattack, spoiling attack, or exploitation or as a result of a movement to contact.

a. **Planning.** In a force-oriented attack against a moving enemy force, the TF normally organizes in the same manner as a movement to contact. Key planning considerations (Figure 5-15, page 5-44) are discussed below.

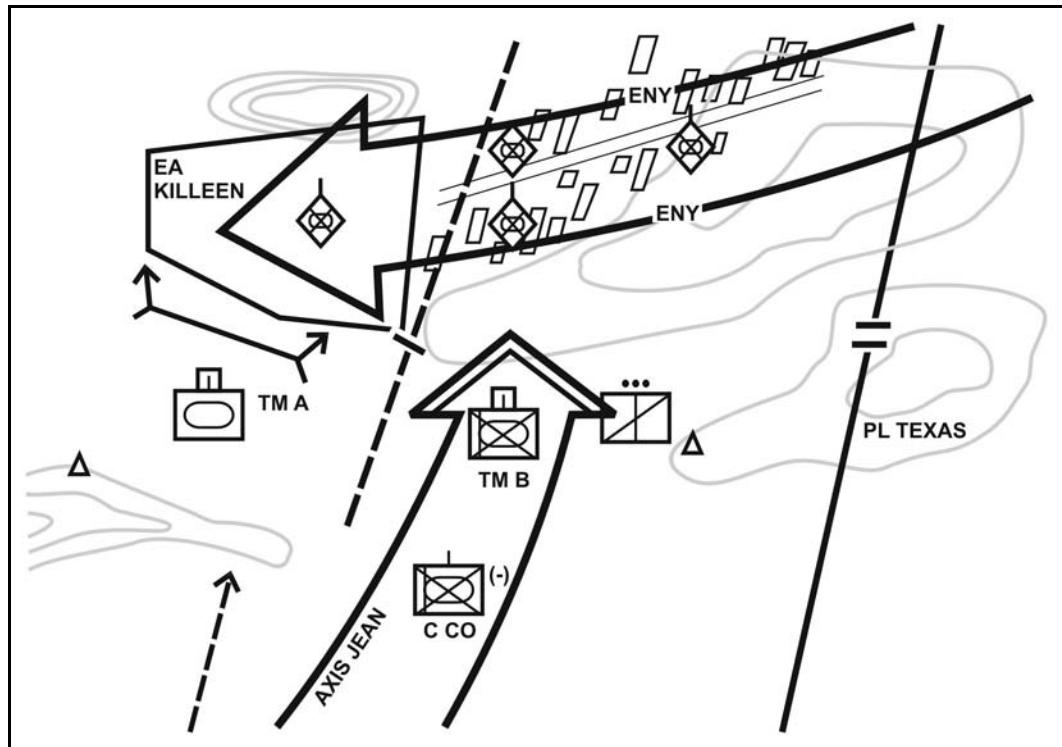
(1) ***Where to Fight the Enemy.*** The decision on where to fight the enemy requires that the commander have information dominance over the enemy. The commander bases his decision on a clear understanding of the effects of the terrain, the enemy situation, and what the enemy is expected to do. The commander and his staff select the most advantageous location to fight the engagement and then determine other possible locations where the engagement may occur based on a slower- or faster-than-expected enemy advance or the enemy's use of an unlikely avenue of approach. They identify these areas as objectives or AOs. The commander and staff must develop control measures to help coordinate actions throughout the TF's battle space. The commander, assisted primarily by the S3 and S2, develops DPs for the commitment of the TF to each location based on relative locations and rates of movement of the TF and the enemy. The S2 carefully selects NAIs to identify the enemy's rate and direction of movement to support the commander's decision of where to fight the engagement.



**Figure 5-15. Planning the attack.**

(2) *Maximizing the Advantages of the Terrain.* The commander uses the terrain to maximize the TF's freedom of maneuver and lethality while limiting the freedom of maneuver available to the enemy. He looks for avenues of approach that allow the TF to strike the enemy from a flank or the rear. One or two company teams block the enemy's advance while the other company teams attack into the enemy's flank. In this example, the terrain prevents the enemy from moving away from the main attack while also protecting the TF's flank from an enemy attack (Figure 5-16).





**Figure 5-16. Example of a task force flank attack.**

(a) Although he develops plans to fight the enemy at the most advantageous location for the TF, the commander retains enough flexibility to attack the enemy effectively regardless of where the engagement develops. The COP provides subordinate commanders the same picture available to the TF commander and enables them to anticipate changes to the base plan. The scheme of maneuver includes provisions to fight the enemy in other AOs or objectives. For simplicity, the commander seeks to keep the scheme of maneuver in each AO or objective as similar as possible.

(b) In some situations, such as a movement to contact, the TF may have constraints in the time or ability to select when and where to fight a moving enemy force. If so, the commander orders the TF into the attack through the use of a FRAGO based on his personal assessment and physical view of the battlefield. As the intelligence community pushes for information, the commander quickly deploys and maneuvers the TF to develop the situation and defeat the enemy.

(3) **Fire Support.** The following are key considerations for the FS plan.

(a) Use fires to affect the enemy's maneuver well forward of the TF, disrupting the enemy's formations and timetable.

(b) Destroy HPTs and security forces.

(c) Carefully plan triggers, observer locations, and targets to maintain flexibility and ensure achievement of required effects prior to contact with the enemy.

(d) Coordinate and synchronize with brigade the movement and positioning of artillery (coordinate terrain requirements) to support EFSTs within each objective or AO and to engage HPTs before the enemy enters the selected objective or AO.

(e) Retain flexibility to mass fires at the decisive point where the battle may occur.

(f) Plan triggers to put targets into effect and cancel them based on the TF's movement and the commander's decision of where to fight the enemy.

(g) Synchronize the movement and positioning of the mortar platoon with the scheme of maneuver.

(4) **Engineer Support.** The following are key considerations for the scheme of engineer operations.

(a) Task-organize engineer forces well forward to support breaching.

(b) Normal priority of support is to the lead company team.

(c) Be prepared to bypass or breach enemy situational obstacles.

(d) Integrate situational obstacles with fires to affect the movement of the enemy in support of the commander's intent.

(e) Plan obstacle belts, obstacle control measures, and situational obstacles to support flank security.

(f) Develop and adjust obstacles and triggers for execution based on the TF's movement and the enemy situation.

(5) **Air Defense Support.** The ADA battery supporting the brigade operates in general support (GS) to the TFs with the normal priority of protection to the main effort. ADA assets shift locations on the battlefield as required by the phase of the operation to maintain adequate air defense coverage of critical forces and events. Normally, Linebacker platoons are forward with the Avenger platoon farther back protecting the brigade CPs and other high-value assets. ADA coverage increases in areas and activities most vulnerable to air attack such as breaching operations or movements through restricted terrain.

(6) **Nuclear, Biological, Chemical Support.** The NBC assets are employed in a similar manner to their employment in an attack against a stationary force. Smoke and NBC reconnaissance assets typically support the main effort.

(7) **Combat Service Support.** The following are key considerations for the CSS plan.

(a) Continuously update the CSS plan. Ensure the CSS plan is responsive and flexible enough to support all maneuver options. Plan support from initiation of the operation to the final objective or LOA.

(b) Integrate refueling and resupply operations with the scheme of maneuver.

(c) Weigh the risk the extended distances create for security of MSRs and CSS assets based on the potential of undetected or bypassed enemy forces.

(d) Use all available assets to develop and maintain an accurate enemy picture behind the lead maneuver elements.

(e) Plan and rehearse for enemy contact.

(f) Plan and coordinate the locations, displacements, and routes of CSS assets to maintain responsive support.

(g) Plan and develop triggers for activating and deactivating collection points and LRPs based on the TF's scheme of maneuver.

(h) Plan MEDEVAC, resupply, and equipment recovery to support anticipated engagements within each AO or objective.

b. **Preparation.** Preparation for an attack against a moving enemy force may be limited because the opportunity to attack the enemy at the appropriate time and place depends on the enemy's movement. This forces the TF to focus the preparation on executing fires and maneuver actions within each AO or objective. The commander

prioritizes each AO or objective area to ensure the TF prepares for the most likely engagements first. The commander must ensure all subordinate company teams and supporting forces understand their role in each AO or objective area and the decision point for execution of each. The leaders of the TF rehearse actions for each COA against various enemy conditions to promote flexibility and initiative consistent with the commander's intent. Repetitive rehearsals against likely enemy actions are essential for success at all levels.

c. **Reconnaissance.** The ISR effort focuses on answering the CCIR to support the commander's decisions on when and where to initiate fires, where to fight the enemy, and how best to maneuver the TF against the enemy. The S2 develops NAIs to identify enemy actions and decisions that indicate the enemy's selected COA. The following are key intelligence considerations for attacking a moving enemy force.

(1) **Understand the Effects of the Terrain.** The commander must understand the effects of terrain on the TF and the enemy. This has the greatest impact on deciding where to fight the enemy. The S2 conducts a detailed terrain analysis and specifically identifies--

- Locations and tactical advantages of key terrain.
- Avenues of approach and mobility corridors for both enemy and friendly forces.
- Advantageous locations for the TF to fight the engagement.
- Danger areas where friendly or enemy forces may become vulnerable. (Examples include restricted terrain, choke points, obstacles, terrain that naturally exposes a flank, and areas dominated by key terrain.)
- Likely rates of movement for both forces.

(2) **Anticipate the Enemy's Selected COA.** The IPB details how the enemy is likely to move and fight. It emphasizes the enemy's likely formation(s) and routes and how he will attempt to fight the ensuing meeting engagement.

(a) The analysis illustrates the enemy's expected rate of movement and how the enemy force is likely to be arrayed based on a detailed terrain and time-distance analysis. The enemy normally has three general COAs:

- Assume a hasty defense either before or after initial contact to retain control of defensible terrain or limit the advantages the TF may have.
- Attack to defeat or penetrate the TF.
- Attempt to delay or bypass the TF.

(b) The S2 develops enemy COAs based on the enemy's likely objective, capabilities, strength, and known tactics. The S2 determines those enemy actions that may indicate the enemy's selection of a COA and ensures observers are positioned to detect and report these indicators. The S2 must always portray the enemy's flexibility, likely actions, and available maneuver options. The goal is to identify the enemy's most likely COA and have the TF anticipate and prepare for it.

(3) **Gain and Maintain Contact.** Preferably, the TF establishes contact with the enemy using digital sensor platforms well before it makes physical contact.

(a) The TF, with support from brigade, receives intelligence from battlefield surveillance assets such as radar, UAVs, access to JSTARS, and other sensors used to track the moving enemy force. Intelligence gathered by these sensors helps the TF direct

ground reconnaissance assets to advantageous positions to observe and report information on the enemy. Once made, the TF maintains contact.

(b) The information gained from the sensors as well as ground reconnaissance elements must be shared with all elements of the TF as quickly as possible. Information requirements normally include--

- The enemy's rate and direction of movement.
- The enemy's formation, strength, and composition. This includes locations of security forces, main body, reserves, and artillery formations.
- Enemy actions and decisions that indicate a future enemy action or intention.
- Location of enemy HPTs.
- Location, type, and activity of key combat multipliers the TF commander intends to attack, such as artillery, engineers, air defense, and logistics.
- Enemy vulnerabilities such as exposed flanks or force concentrations at obstacles.

(4) **Support the TF's Movement.** Reconnaissance and surveillance forces move well forward of the TF. They reconnoiter obstacles and areas that may slow the TF's movement and disrupt the timing and planned location of the attack. They seek to detect obstacles, contaminated areas, enemy security forces, and suitable routes for the TF's use.

(5) **Report Enemy Actions on Contact.** As the engagement develops, reconnaissance assets continue to report enemy actions, BDA, and locations. Reconnaissance assets must occupy positions that provide good observation of the engagement and are survivable throughout the course of the engagement.

d. **Execution.** The following considerations apply to the conduct of the attack.

(1) **Maximize the Approach to the Objective.** The TF moves with deliberate speed. By gaining contact with the enemy force quickly through the reconnaissance and surveillance force, the Brigade can use long-range fires and CAS to destroy and disrupt the enemy throughout his formation.

(a) The TF deploys, masses effects, and destroys the remaining enemy before he can adequately react. The commander adjusts the speed of the TF to ensure that fires have set appropriate conditions and that the TF arrives at the designated engagement area (EA) at the proper time in relation to the enemy. Effective reporting and analysis of the enemy's rate and direction of movement by reconnaissance and surveillance elements are critical to the timing of the attack.

(b) The commander seeks to conceal the movement of the TF from the enemy to maintain surprise. The TF, moving dispersed, masks its movement and maximizes its use of routes that provide cover and concealment. The use of all current information available to enhance positive control of movement formations by all subordinate units is essential to the TF's ability to mass against the enemy. The TF employs a robust reconnaissance effort to detect and destroy enemy security forces that may warn the enemy force of friendly actions.

(2) **Take Action on the Objective.** The TF creates favorable conditions for decisive action by weakening and disrupting the enemy's formation, destroying his security forces, and fixing the enemy's main body. The TF achieves final destruction of the enemy through its main body's attack.

(3) **Disrupt and Weaken the Enemy's Formation.** The TF employs direct and indirect fires reinforced with situational obstacles to set the conditions for EA fights,

disrupting and weakening the enemy before he gets to the EA. Indirect fires should provide time for the TF to deploy before contact. Scouts normally control these initial fires.

(4) ***Defeat Enemy Security Forces.*** The enemy normally employs security forces to protect his main body. The enemy's ability to seize the initiative often rests on his security forces. The TF must avoid, destroy, or fight through the enemy's security forces to gain contact with the bulk of the enemy force. The commander employs fires in conjunction with his advance guard to defeat the enemy's security forces so the TF's main body can decisively attack the bulk of the enemy force. Ideally, the TF's advance guard attacks the enemy's forward or flank security forces to develop the situation. The commander weights the advance guard with maneuver forces and indirect fires in order to destroy the enemy's security force rapidly and gain contact with the enemy's main body before the enemy can effectively react.

(5) ***Fix the Enemy.*** The TF normally fixes the enemy main body to create the conditions for the main body's attack. Normally, the TF's advance guard executes this task once it destroys the opposing enemy security force. Indirect fires against the lead enemy forces allow the advance guard to deploy and gain contact with the enemy main body. The advance guard commander keeps the TF commander informed of the enemy's strength and actions. It is paramount that the TF commander receive accurate, timely reports and analysis of the enemy situation. Reconnaissance elements assist the advance guard commander in providing accurate information to the TF commander. The TF commander must know the enemy main body's strength, disposition, and reactions. He uses this information to make final adjustments to the main body's attack.

(6) ***Maneuver the Main Body.*** As the advance guard develops the situation, the commander begins to maneuver the main body to a favorable position for commitment.

(a) The commander positions the TF to attack the enemy formation from an assailable flank where its total combat power can be massed against an enemy weakness to reach a quick decision. Rapid movement and massed fires characterize this attack. Indirect fires shift to suppress the enemy force that directly opposes the main body's attack. The main body strikes the enemy force with overwhelming strength and speed. As the main body maneuvers against the enemy, the TF FSO adjusts FSCMs to provide continuous support and ensure force protection.

(b) If the commander determines the enemy force is attempting to bypass or avoid contact, he immediately directs indirect fires to delay and disrupt the enemy's movement away from the TF. The commander maneuvers his forces to quickly destroy or penetrate any enemy forces attempting to fix or delay the TF and strikes the bulk of the evading enemy force from the flank or rear.

(c) Current tactical information is paramount for the rapid commitment of fires and maneuver forces during these decisive maneuvers. All commanders involved must know the location of enemy and friendly forces. Subordinate commanders must anticipate the TF commander's decisions and have their subordinates ready to execute. They must also anticipate the shifting of indirect fires since the fire support elements can see and understand the battle as it takes place. Proper use of the COP enhances the coordination and integration of all elements.

## 5-20. TERRAIN-ORIENTED ATTACKS

Terrain-oriented attacks require the TF to seize or secure a designated area to support future operations. The TF attacks to seize terrain-oriented objectives for many reasons, for example--

- To seize key terrain or structures such as bridges, airfields, or public services to support follow-on operations.
- To seize terrain such as choke points or routes to block enemy withdrawals, reinforcements, or movements against the brigade's main effort.
- To secure an area to allow future operations such as a lodgment area.

The TF plans and executes terrain-oriented attacks (Figure 5-17) in the same manner as attacks against enemy forces. The major distinction in a terrain-oriented attack is that the TF focuses its efforts on the seizure and holding of terrain instead of the total destruction of the enemy. The commander plans and controls the attack to gain control of the terrain as quickly as possible and conducts only necessary actions against the enemy. Success of the mission does not normally entail decisive action against all enemy forces within the AO. The TF attacks only those enemy forces that directly affect the seizure of the objective or that may impact on the future operation. Other key planning considerations that differ from force-oriented attacks include the following:

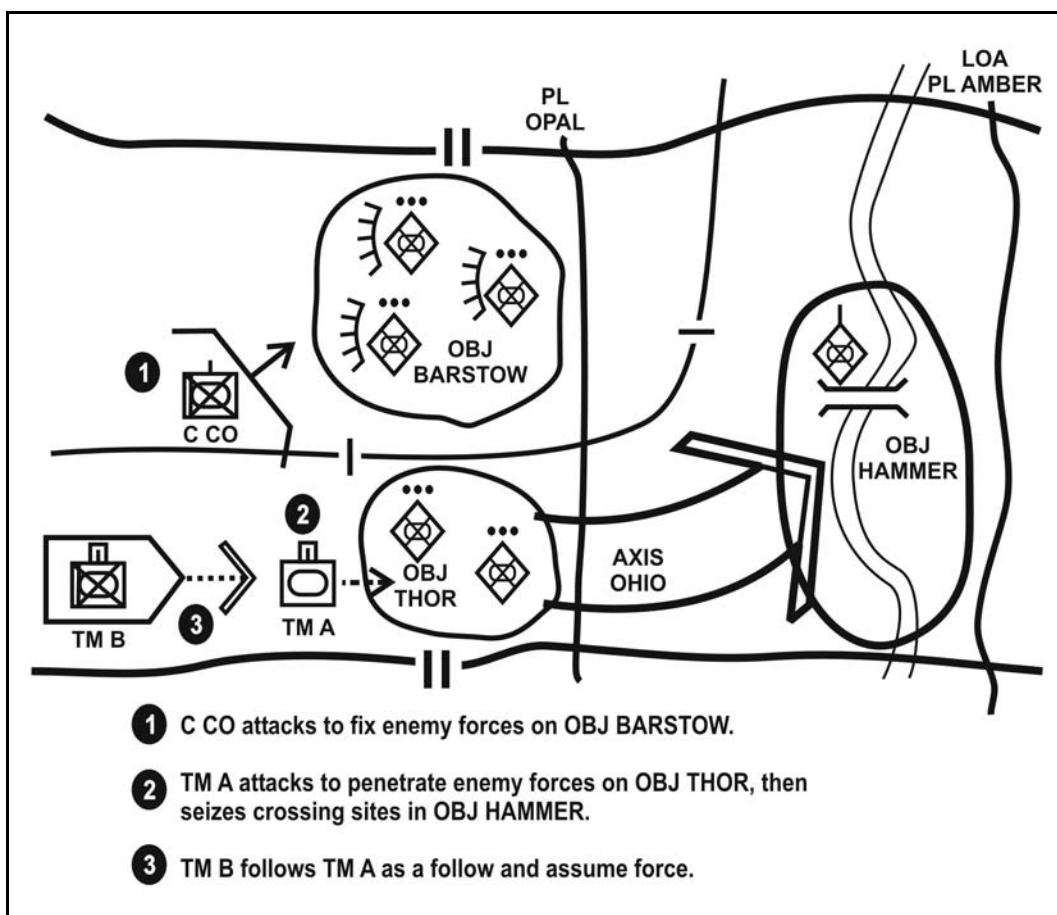


Figure 5-17. Terrain-oriented attack.

a. **Reconnaissance.** The ISR effort, as in other attacks, capitalizes on all the battlefield surveillance assets available to the brigade as well as those that belong to the TF to identify the enemy situation on the objective and any sizable enemy forces within the TF's battlespace. TF ground reconnaissance elements occupy advantageous positions to gain observation and report information on the enemy.

(1) The commander must consider enemy forces within his battlespace, specifically in areas outside his AO but inside his AI, that may react to the TF's seizure of the objective. Once the TF locates enemy forces, reconnaissance forces seek to determine the full extent of the enemy's strength and disposition as well as possible bypasses the TF may exploit.

(2) The commander, assisted by the S2, seeks to identify the possible reactions of enemy forces within his battlespace to the TF's attack. The plan should retain the necessary flexibility to succeed against all likely enemy reactions. As the S2 develops enemy COAs, he must identify those indicators that reveal the enemy's commitment to a future action. He normally considers enemy actions to defend in place, reinforce threatened enemy units, counterattack, delay, or possibly withdraw.

b. **Degree of Risk.** The commander must determine the degree of tactical risk he is willing to accept by leaving or bypassing enemy forces in the TF's AO. He bases this decision on the higher commander's intent and established bypass criteria, the enemy's capabilities, and the commander's assessment of the situation. The commander must recognize the potential effects that bypassed enemy forces may have on the TF's CSS operations and future operations. The commander normally employs economy of force missions to contain, guard, or fix bypassed enemy forces. The tactical risk imposed by these bypassed forces is reduced by accurate and timely reporting of their locations and status by way of FBCB2 throughout the TF, especially to the elements moving behind the maneuver forces in the TF's AO. Once the TF secures the objective, other forces or fires can destroy bypassed enemy forces or force their surrender.

c. **Seizure of the Objective.** Once it seizes the objective, the TF conducts a hasty defense of the area to prevent the enemy from recapturing it. The commander seeks to position his forces in a manner that best defends the objective while allowing a rapid transition to follow-on operations. Reconnaissance and security forces push forward of the objective to identify any enemy forces approaching the secured objective. Engineers provide countermobility and survivability support as required.

## 5-21. EXPLOITATION

Exploitation is not normally conducted below the brigade level. An exploitation often follows a successful attack to take advantage of a weakened or collapsed enemy. The purpose of exploitation can vary, but it generally focuses on capitalizing on a temporary advantage or preventing the enemy from establishing an organized defense or conducting an orderly withdrawal. To accomplish this, the brigade (or higher level unit) attacks rapidly over a broad front to prevent the enemy from establishing a defense, organizing an effective rear guard, withdrawing, or regaining balance. The brigade secures objectives, severs escape routes, and destroys all enemy forces. Failure to exploit success aggressively gives the enemy time to reconstitute an effective defense or regain the initiative by a counterattack.

a. The conditions for exploitation develop very quickly. Often the lead TF in contact identifies the collapse of the enemy's resistance. The brigade commander must receive accurate assessments and reports of the enemy situation to capitalize on the opportunity for exploitation. Typical indications of the conditions for exploitation include--

- A significant increase in EPWs.
- An increase in abandoned enemy equipment and materiel.
- The overrunning of enemy artillery, C2 facilities, and logistics sites.
- A significant decrease in enemy resistance or in organized fires and maneuver.
- An intermixing of support and combat vehicles in formations and columns.
- An increase in enemy rearward movement, especially of reserves and FS units.

b. Should the TF conduct exploitation as part of a larger operation, it may have the mission to seize a terrain-oriented objective. In this case, the TF avoids decisive engagement and moves to the objective as quickly as possible. If assigned a force-oriented objective, the TF seeks and destroys enemy forces anywhere within its AO. The exploitation ends when the enemy reestablishes its defense, all organized enemy resistance breaks down, or the friendly force culminates logistically or physically.

## **5-22. PURSUIT**

The TF does not conduct a pursuit as an independent action. Even at the brigade level, the risks associated with a pursuit operation generally outweigh the benefits. However, if provided aviation assets or additional ground maneuver units, the brigade can conduct a pursuit. If so, the TF can serve as the direct-pressure force or the encircling force.

a. A pursuit is ordered when the enemy can no longer maintain a coherent position and tries to escape. Once ordered, the COP between the pressure and encircling forces is critical for the necessary synchronization. The brigade's mission is the destruction of the enemy rather than avoiding enemy contact.

b. The direct-pressure force organizes for a movement to contact and prepares to conduct a series of hasty attacks. Encirclement results when a force is able to sever the enemy's lines of communication and prevent his reinforcement or escape. The encircling force must have greater mobility than the enemy. The encircling force is usually created from uncommitted forces and must be strong enough to protect itself from the enemy's reserves and what is left of the main body. The direct-pressure force must track the movement of and coordinate with the encircling force. Timing is key to success of the mission, and information systems are key to this synchronization. The encircling force should be prepared to conduct a hasty defense until the direct-pressure force succeeds in destroying or forcing the enemy to surrender. The ultimate goal of a pursuit is to fix the enemy between the direct-pressure force and the encircling force and then to destroy the enemy.

## **5-23. SPECIAL-PURPOSE ATTACKS**

The TF can launch attacks with various purposes to achieve different results. These forms of attack include raids, feints, demonstrations, counterattacks, and spoiling attacks.

a. **Raid.** A raid is a deliberate attack that involves the swift, temporary penetration of enemy territory for a specific mission. A raid usually ends with a planned withdrawal.



Raids are usually small-scale attacks, requiring detailed intelligence, preparation, and planning.

(1) Typical raid missions accomplish the following:

- Capture prisoners, installations, or enemy materiel.
- Destroy enemy materiel or installations.
- Obtain specific information on an enemy unit such as its location, disposition, strength, or operating scheme.
- Deceive or harass enemy forces.
- Liberate captured friendly personnel.

(2) The raiding force may vary in size from an infantry platoon to a battalion task force. It may operate within or outside the TF's supporting range. The raiding force moves to its objective by land, air, or water for a quick, violent attack. Once it completes the raid mission, the raiding force quickly withdraws along a different route. The following are specific planning considerations for a raid mission.

(a) Conduct detailed reconnaissance and maintain constant surveillance of the raid objective to ensure the enemy situation remains unchanged and within the capability of the raiding force. Support from outside the TF helps to provide the intelligence needed to plan and conduct a raid successfully.

(b) Position FS systems to provide immediate responsive fires during the approach, actions on the objective, and withdrawal. Interdiction fires, deception fires, counterfires, and situational obstacles reduce the enemy's ability to react to the raid.

(c) Security is vital because the raiding force is vulnerable to attack from all directions.

(d) Establish clear abort criteria for the raid. These may include loss of personnel, equipment, or support assets and changes in the enemy situation.

(e) Develop contingency plans for contact prior to and after actions on the objective.

(f) Plan casualty evacuation and raiding force extraction throughout the entire depth of the operation.

(g) Plan rally points for units to assemble to prepare for the attack or to assemble after the mission is complete and the force is ready to withdraw.

(h) Consider logistical factors such as the types and numbers of vehicles and weapons that the raiding party will have, movement distance, length of time the raiding party will operate in enemy territory, and expected enemy resistance. Aircraft or linkup provides CASEVAC or resupply of the raiding force, if required, during the withdrawal.

(i) Conduct withdrawal over a different route than that used to approach the objective.

(3) The TF may participate in an artillery raid as part of a division or corps operation. In such an operation, the TF supports the positioning of artillery. If necessary, the TF fights through enemy forces to get the artillery unit to the position required to strike the enemy deep as part of the division or corps effort to set the conditions for an attack at their level.

b. **Feint.** A feint is a form of an attack intended to deceive the enemy and draw attention and combat power (if possible) away from the main effort.

(1) Feints must be of sufficient strength and composition to cause the desired enemy reaction. Feints must appear real; therefore, some contact with the enemy is necessary. The feint is most effective under the following conditions:

- When it reinforces the enemy's expectations.
- When it appears to be a definite threat to the enemy.
- When the enemy has a large reserve that it has consistently committed early.
- When there are several feasible COAs open to the attacker.

(2) The purposes of a feint may include the following:

- To force the enemy to employ his reserves away from the main effort or to remain in position.
- To attract enemy supporting fires away from the main effort.
- To force the enemy to reveal defensive fires or weaknesses.
- To accustom the enemy to shallow attacks in order to gain surprise with another attack.

(3) Planning for a feint mission follows the same sequence as any other attack. Special planning considerations include the following:

- Ensure the feint is resourced to appear as the main effort or as a significant threat to the enemy.
- Establish clear guidance regarding force preservation.
- Ensure adequate means of detecting the desired enemy reaction.
- Designate clear disengagement criteria for the feinting force.
- Assign attainable objectives.
- Issue clear follow-on missions to the feinting force.

c. **Demonstration.** A demonstration is a form of an attack used for deception. It is made with the intention of deceiving the enemy; however, contact with enemy forces is not sought. Demonstrations support a division or corps plan; TFs do not conduct demonstrations alone. Demonstrations must be clearly visible to the enemy without being transparently deceptive in nature. Demonstration forces use fires, movement of maneuver forces, smoke, EW assets, and communication equipment to support the deception plan. Planning considerations include the following:

- Establish a LOA for demonstration forces that allows the enemy to see the demonstration but not to engage it effectively with direct fires.
- Establish other security measures necessary to prevent engagement by the enemy.
- Employ demonstrations to reinforce the enemy's expectations and contribute to the main effort.
- Develop contingency plans for enemy contact to avoid becoming decisively engaged.
- Issue clear follow-on missions to the demonstration force.
- Establish the means to determine the effectiveness of the demonstration and assess its effect on the enemy.

d. **Counterattack.** A counterattack is an attack launched from the defense to defeat an attacking enemy force or regain key terrain and ultimately regain the initiative. The counterattack is often the deciding action in the defense and becomes the main effort upon commitment. The commander may plan counterattacks as part of the TF's defensive plan, or the TF may be the counterattack force for the brigade or division.

e. **Spoiling Attack.** A spoiling attack is an attack launched from the defense to disrupt the enemy's attack preparations. Spoiling attacks focus on the enemy's critical

systems and forces that have the greatest impact on his ability to mount an attack. Lucrative targets include C2 systems, intelligence assets, FS, and logistics. Spoiling attacks may be conducted as often as needed to deny adequate attack preparation to the enemy. The TF normally conducts a spoiling attack as part of the higher headquarters operation. Spoiling attacks are planned and executed in the same manner as an attack.

#### **Section IV. TRANSITION OPERATIONS**

The TF spends minimum time after concluding an engagement or actions on the objective to consolidate and reorganize before continuing the attack. If consolidation and reorganization is required, the commander decides the best time and location to facilitate future operations and provides force protection. The TF must maintain a high degree of security when performing consolidation and reorganization activities.

##### **5-24. CONSOLIDATION**

Consolidation is the process of organizing and strengthening a newly captured position. The TF may need to consolidate to reorganize, avoid culmination, prepare for an enemy counterattack, or allow time for movement of adjacent units. The TF makes consolidation plans for every mission, updates them during the attack, and passes them to units as the attack is completed. Actions during consolidation include--

- Reestablishing communications (if required).
- Eliminating pockets of enemy resistance.
- Establishing security consistent with the threat.
- Establishing contact (electronic, physical, or both) with adjacent friendly units.
- Preparing defensive positions.
- Clearing obstacles or improving lanes to support friendly movement and reorganization activities.
- Planning and preparing for future operations.
- Destroying captured enemy equipment and processing EPWs.
- Maintaining contact with the enemy and conducting reconnaissance.
- Cross-leveling and conducting emergency resupply.

The TF maintains contact with the enemy by redirecting the scout platoon, directing small-unit patrols, pulling the latest intelligence from the higher brigade ACT and S2, and possibly conducting limited objective attacks.

##### **5-25. REORGANIZATION**

Reorganization planning begins before and continues during the attack as losses occur. Company teams must feed reports to the TF as losses occur so that the information entered into the CSS system allows reporting of casualties and movement of needed resupply and or replacements forward to arrive as the TF begins reorganization. The TF immediately takes all measures required to maintain its combat effectiveness or return to a specified level of combat capability. If extensive reorganization is required, the TF conducts it during consolidation. Reorganization tasks include--

- Establishing, if required, new tactical internet, unit task organization (UTO), and digital connectivity (in units equipped with FBCB2).
- Establishing and maintaining security.

- Reestablishing the TF chain of command, key staff positions, and C2 facilities lost before or during the battle.
- Treating and evacuating casualties.
- Recovering and repairing damaged equipment as necessary.
- Redistributing ammunition, supplies, and equipment as necessary.
- Conducting resupply and refueling operations.
- Repositioning C2 facilities, communications assets, and logistics for future operations.
- Reorganizing company teams and platoons if losses have occurred.

**5-26. CONTINUING OPERATIONS**

For all missions assigned, the TF should plan for exploiting success. However, at the conclusion of an engagement, the commander may be forced to defend. The commander considers the higher commander's concept of operations, friendly capabilities, and the enemy situation when making the decision to defend or continue offensive operations.

**5-27. DEFEND**

The TF conducts a defense when directed by higher headquarters, to repel an enemy counterattack, to avoid culmination, or to complete reorganization activities. The TF occupies the most defensible terrain, which may require the TF to attack to seize defensible terrain. Normally, the TF pushes its scout platoon out to establish a security area to provide reaction time and early warning of enemy actions. Subordinate company teams occupy designated AOs, quickly array forces, and develop fire plans. Normally, the commander seeks to array company teams to achieve an adequate level of defense and facilitate future operations. Engineers provide survivability support and emplace obstacles as required to support the defense.

---

## CHAPTER 6

# DEFENSIVE OPERATIONS

*The immediate purpose of defensive actions is to resist, defeat, or destroy an enemy attack and gain the initiative for the offense. Defensive operations defeat an enemy attack, buy time, economize forces, or develop conditions favorable for offensive operations. Defensive actions alone are not decisive; they must be combined with or followed by offensive action. The TF defends temporarily to create the conditions necessary to resume offensive operations in order to defeat the enemy decisively. As part of the brigade, the TF may defend, conduct retrograde operations, counterattack, or perform security operations or economy of force tasks. Often, a defensive engagement requires the task force to execute several of these tasks over its course. Even within the conduct of a brigade defense, the task force exploits opportunities to conduct offensive operations within its AOs to deprive the enemy of the initiative and create the conditions to assume the offensive.*

### Section I. FUNDAMENTALS OF THE DEFENSE

This section discusses the fundamentals of the defense as they apply to the tank and mechanized infantry battalion task force.

#### 6-1. PURPOSE OF THE DEFENSE

The main purpose of the defense is to force or deceive the enemy into attacking under unfavorable circumstances, defeat or destroy his attack, and regain the initiative for the offense. The defending commander seeks to dictate where the fight will occur, preparing the terrain and conditions to his advantage while simultaneously denying the enemy adequate intelligence. Defense is a temporary measure used to identify or exploit enemy weaknesses. Use of the defense provides the opportunity to transition to the offense. In general, the TF defends to--

- Defeat or destroy an attacking enemy.
- Increase the enemy's vulnerability by forcing him to concentrate his forces.
- Gain time.
- Deny enemy entry into an area or retain terrain.
- Economize forces in one area to apply decisive force elsewhere.
- Prepare to resume the offensive.
- Develop favorable conditions for offensive actions.
- Reduce the enemy's capability for offensive operations.

#### 6-2. ORGANIZATION OF DEFENSIVE ACTIONS

Defensive operations are organized around a framework of a security area and a main battle area.

a. **Security Area.** The brigade normally establishes a security force to provide early warning, reaction time, and initial resistance to the enemy. Depending on the brigade

commander's guidance and plan, the TF has several possible security force missions and options. The TF may--

- Establish a security area layered behind the brigade's security area to add depth to the effort.
- Secure its own flanks and rear while brigade assets conduct the primary security area effort forward of the FEBA.
- Conduct its own security effort in the absence of a higher echelon security force.
- Provide units for the brigade security force. This could include the scout platoon, mortar platoon, or both; maneuver platoons or company teams; or the entire TF.

(1) **Security Area Definition.** The brigade commander defines the brigade's security area, the battle handover line from brigade to TF, the exact trace of the FEBA, and where he envisions the main TF fight will occur. From this the TF commander can determine how to structure his security area and the array of forces to employ. If the TF commander must organize his own security force, he chooses from three basic options:

- Use the scout platoon only as a screening force.
- Use the scout platoon in conjunction with maneuver elements, mortars, or a company team (or in combination) in a guard mission.
- Use a company team with or without the scout platoon and mortars in a guard mission.

(2) **Specific Guidance and Tasks.** No matter what task organization he implements, the commander should provide the force with specific guidance and tasks. This may include--

- Duration of the mission.
- Results to be achieved against the enemy.
- Specific CCIR with associated NAIs and TAIs.
- Avenues of approach to be monitored with PIR and LTIOV.
- CS and CSS.
- Disengagement and withdrawal criteria and rearward passage coordinating instructions.
- Follow-on tasks or missions.

(3) **Simultaneous Missions.** Using TF resources to establish a security area while simultaneously requiring the TF to defend the MBA is risky and divides the attention of the commander. Whenever possible, this should be avoided.

b. **Main Battle Area.** The brigade and its TFs deploy the bulk of their combat power in the MBA. The brigade MBA extends from the FEBA to the rear boundary of the forward TFs. TF main battle areas are subdivisions of the brigade's MBA. The FEBA marks the foremost limit of the areas in which the preponderance of ground combat units deploy, excluding the areas in which security forces are operating. The brigade commander assigns the TF MBAs by establishing unit boundaries. Brigade and TF commanders establish areas of operation, battle positions, or strongpoints to implement their concepts of operations. As in all operations, commanders promote freedom of action by using the least restrictive control measures necessary to implement their tactical concepts (Figure 6-1).

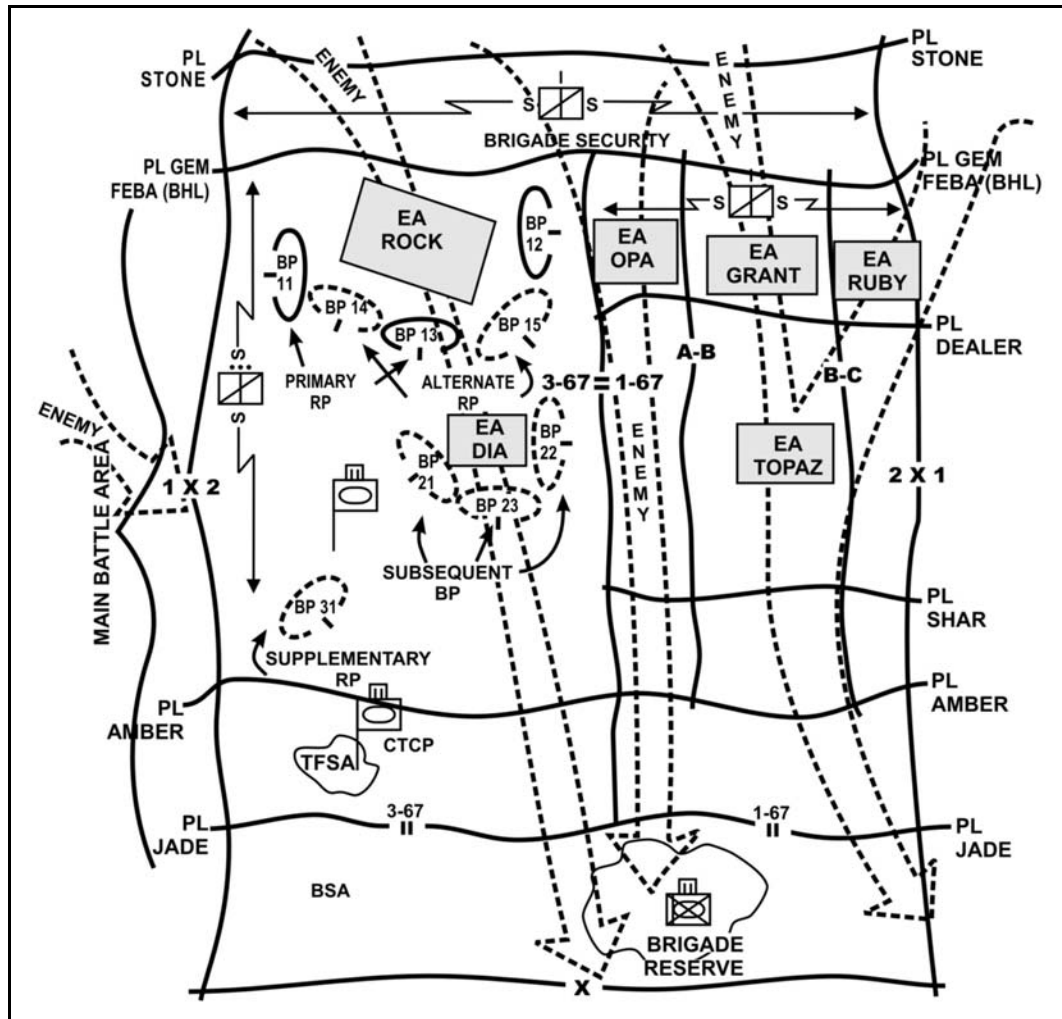


Figure 6-1. Sample defensive graphics for linear operations.

### 6-3. CHARACTERISTICS OF THE DEFENSE

Much like offensive operations, the TF differs from its more traditional counterparts only in its operational style. The characteristics of the defense remain largely unchanged. Due to its advantages in information, lethality, and mobility, the TF can defend in linear as well as nonlinear frameworks. The ISR capabilities provided by brigade, as well as those within the TF structure, enable the TF to locate and discern the enemy's main and supporting efforts. Preparation, security, disruption, massing effects, and flexibility continue to characterize TF defensive operations.

a. **Preparation.** Against an opponent operating in a more conventional style, the TF commander determines likely enemy avenues of approach, likely enemy schemes of maneuver, where to kill the enemy, integration of obstacles, unit positioning, and integration of indirect fires, and he assigns mission accordingly. The S2, S3, and BOS representatives execute the MDMP under the XO's supervision for the commander's approval. The command and control architecture allows the commander to circulate on the battlefield while issuing guidance and approving products throughout the process. The staff is able to interface with brigade and division for sophisticated computer analysis of enemy COAs and friendly plans. Additional defensive preparations include--

- Designate a reserve.
- Conduct rehearsals, to include employment of the reserve and counterattack forces.
- Position forces in depth.
- Reinforce terrain with obstacles to favor the defender.

b. **Security.** Since a force defends to conserve combat power for use elsewhere, or at a later time, commanders must secure the force. The TF ensures security by employing reconnaissance elements throughout the depth and breadth of its assigned AO. Deception and information operations aid in securing the force and confuse the enemy as to the TF's manner of defense. The TF secures the force through integrated security operations tied with the brigade reconnaissance troop and ISR assets.

c. **Disruption.** Defenders disrupt an attacker's tempo and synchronization by countering his initiative and preventing him from massing overwhelming combat power. Disruption attacks the enemy's will to fight. Fires, SCATMINEs, unexpected defensive positions, local counterattacks at all levels, and attacks delivered by a highly mobile striking force combine to disrupt the enemy's attack and break his will to continue offensive operations. Repositioning forces, aggressive local force protection measures, and random employment of roadblocks, ambushes, checkpoints, and information operations combine to disrupt the threat of asymmetrical attack. Attacks on these disrupt enemy efforts to fight as a combined arms team. Maneuver units deceive the enemy as to the nature of their defense and employ local combined arms counterattacks to break the tempo of his attack. The brigade's integrated ISR capability produces dominant situational understanding that allows the commander to "see" and prevent the enemy from fully preparing his attack.

d. **Massing Effects.** The TF shapes and decides the battle by massing (focusing, distributing, and shifting) the effects of overwhelming combat power (direct fire, indirect fire, and obstacles). Effects should be synchronized around an engagement area(s) in time and space and be rapid and unexpected so that they break the enemy's offensive tempo and disrupt his attack.

(1) The commander employs integrated ISR to shift the effects of fires and maneuver forces so that they are repeatedly focused and refocused to achieve decisive, destructive, and disruptive effects upon the enemy's attack. The commander must be audacious in achieving overwhelming combat effects at the decisive point by employing dominant situational understanding to take acceptable risks in other areas.

(2) The critical planning piece for both maneuver and fire support during defensive operations is EA development. Although EAs may also be divided into sectors of fire, it is important to understand that defensive systems are not designed around the EAs but rather around avenues of approach. EAs and sectors of fire are not intended to restrict fires or cause operations to become static or fixed; they are used only as a tool to concentrate fires and to optimize their effects. The seven steps listed below represent a way to build an engagement area. Although listed sequentially, some steps (marked by an asterisk) can and should be done concurrently.

- (a) Identify all likely enemy avenues of approach.
- (b) Determine likely enemy scheme of maneuver.
- (c) Determine where to kill the enemy.
- (d) Plan and integrate obstacles.\*



- (e) Emplace weapon systems.\*
- (f) Plan and integrate indirect fires.\*
- (g) Rehearse the execution of operations in the engagement area.

e. **Flexibility.** The defender gains flexibility by sound preparation, disposition in depth, retention of reserves, and effective command and control. The defense is characterized by rapid simultaneous and collaborative planning with flexible execution. Contingency planning permits flexibility. Flexibility also requires that the commander "see" the battlefield to detect the enemy's scheme of maneuver early. IPB determines likely enemy actions, and security elements confirm or deny those actions.

## **Section II. TYPES OF DEFENSIVE OPERATIONS**

There are three types of defensive actions: area defense, mobile defense, and retrograde operations. Each of these types of defensive actions contains elements of the others and usually contains both static and dynamic aspects. TFs serve as the primary maneuver elements or terrain-controlling units for the brigade in all types of defensive operations. They may defend AOs or positions or may serve as security forces or reserves as part of the brigade coordinated defense.

### **6-4. AREA DEFENSE**

The area defense concentrates on denying an enemy force access to designated terrain for a specific time. Outright destruction of the enemy may not be a criterion for success. The focus is on retaining terrain where the bulk of the defending force positions itself in mutually supporting positions and controlling the terrain between positions. The defeat mechanism is fires into engagement areas, usually supplemented by intervention of a reserve. The commander uses his reserve force to reinforce fires, add depth, block penetrations, restore positions, or counterattack to destroy enemy forces and seize the initiative. Area defenses are conducted when--

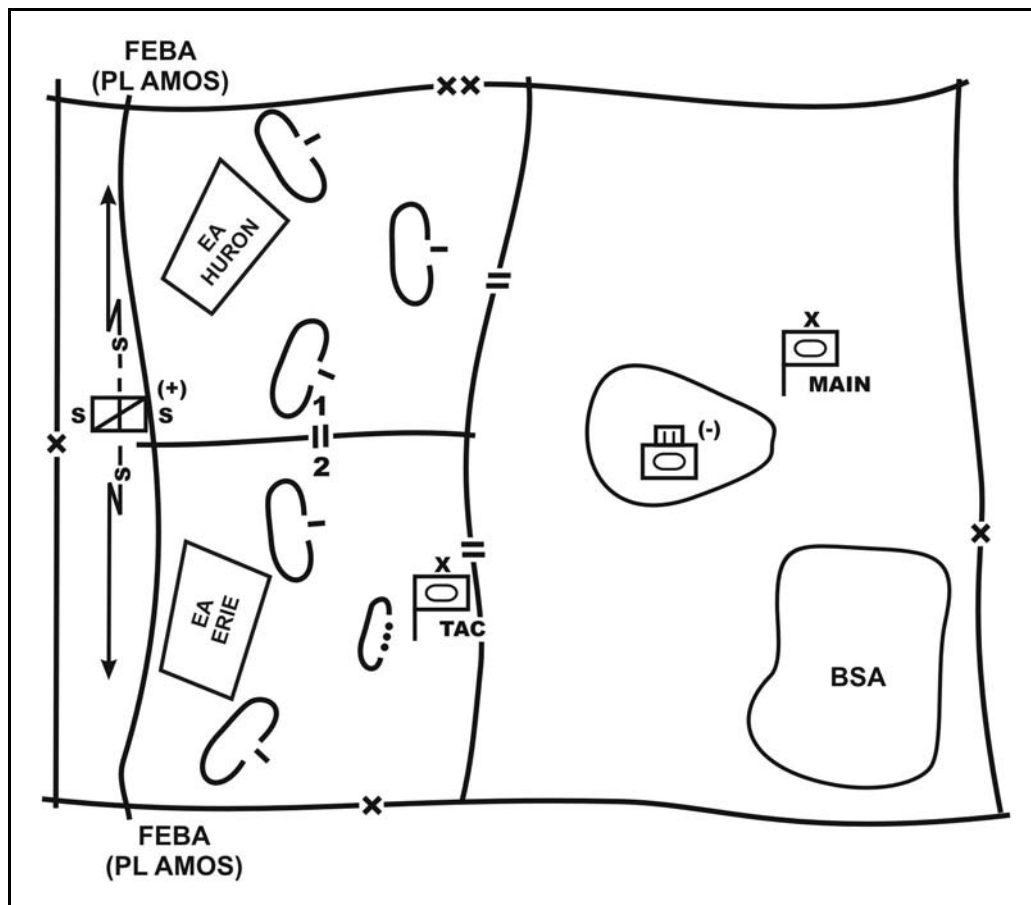
- The mission requires holding certain terrain for a specific period of time.
- There is enough time to organize the position.
- The task force or brigade has less mobility than the enemy.
- The terrain limits counterattacks to a few probable employment options.
- The terrain affords natural lines of resistance and limits the enemy to a few well-defined avenues of approach, thereby restricting the enemy's maneuver.

The TF commander generally selects one of two general techniques for an area defense--forward or defense in depth. However, the higher commander may define the general defensive scheme for the task force. The specific mission may impose constraints such as time, security, and retention of certain areas that are significant factors in determining how the brigade will defend.

a. **Forward Defense.** Due to its inherent lack of depth, the forward defense is the least preferred option. The intent of a forward defense is to limit the terrain over which the enemy can gain influence or control. The TF deploys the majority of its combat forces near the FEBA with the scout platoon establishing a relatively narrow security area (Figure 6-2, page 6-6). The TF fights to retain these forward positions and may conduct counterattacks against enemy penetrations or destroy enemy penetrations in forward engagement areas. While the TF may lack depth, company teams and platoons must build depth into the defense at their levels. The TF can expect to conduct a forward defense for

protection of critical assets or other forces or for political purposes such as defending an ally's threatened border. A TF may defend forward under the following conditions:

- Terrain forward in the AO favors the defense.
- Strong existing obstacles, such as a river, are located forward in the AO.
- The assigned AO lacks depth due to the location of the area or facility to be protected.
- Cover and concealment in the rear portion of the AO is limited.
- Higher headquarters directs the TF to retain or initially control forward terrain.



**Figure 6-2. Example of a forward defense with task force and company teams defending forward.**

b. **Defense in Depth.** A defense in depth is the preferred option when tactical conditions allow. It reduces the risk of the attacking enemy quickly penetrating the defense and affords some initial protection from enemy indirect fires. It also limits the enemy's ability to exploit a penetration through additional defensive positions employed in depth. The defense in depth provides more space and time to exploit intelligence and fire support assets to reduce the enemy's options, weaken his forces, and set the conditions for destruction. It provides the commander with more time to gain information about the enemy's intentions and likely future actions by taking full advantage of

INFOSYS and ISR capabilities before decisively committing to a plan of his own. It also allows the TF to execute decisive maneuver by effectively repositioning company teams to conduct counterattacks or to prevent penetrations (Figure 6-3).

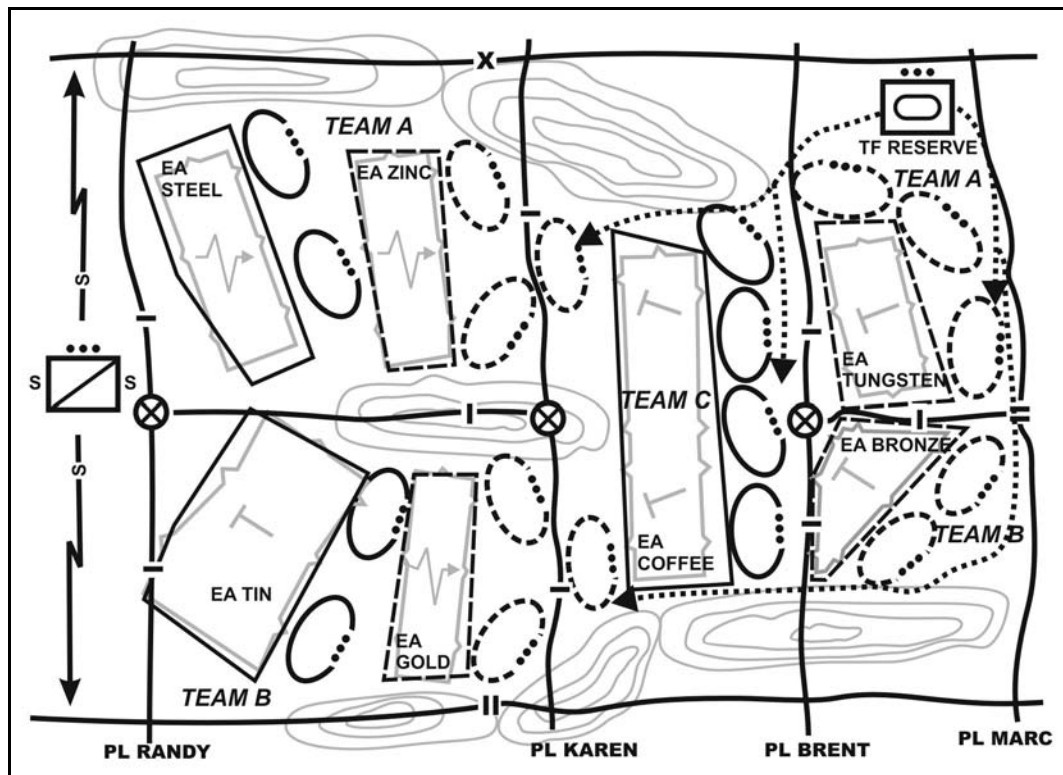


Figure 6-3. Defense in depth.

c. **Planning.** The commander must consider all the factors of METT-TC in order to determine how best to concentrate his efforts and economize forces. Detailed analysis of terrain may be the most important process that the commander and his staff complete. A successful defense relies on a complete understanding of terrain in order to determine likely enemy courses of action and the optimal positioning of the TF assets to counter them. The commander's keys to a successful area defense are--

- Capability to concentrate effects.
- Depth of the defensive area.
- Security.
- Ability to take full advantage of the terrain.
- Flexibility of defensive operations.
- Timely resumption of offensive action.

(1) **Security.** Security is one of the first planning considerations for the TF. The brigade reconnaissance troop, possibly with augmentation, precedes the maneuver TF in order to clarify the tactical situation. The commander must give the scout platoon specific PIR to allow for an efficient occupation of the area of operations and to position itself for the preparation and execution of the area defense. On a noncontiguous battlefield, the security force must be positioned between the protected force and the known or suspected enemy locations.

(2) **Maneuver.** In noncontiguous operations, the TF often must defend either on a broad front or in an AO so large that employing units in mutually supporting positions is unrealistic. This requires a judicious effort by the commander and his staff in determining the positioning of maneuver forces. The TF has the unique ability to defend in restricted and severely restricted terrain with infantry while also being able to cover mounted avenues of approach or open areas effectively with tanks and BFVs. During the terrain analysis, the commander and staff must look closely for choke points, intervisibility lines, and reverse slope opportunities in order to take full advantage of the TF's capabilities to mass firepower while providing protection for the infantry.

(a) Once the commander has assigned areas of operations to his maneuver units, he must determine any potential gaps between units. The TF should plan to cover these gaps with reconnaissance assets, aggressive patrolling from the company teams, and local observation posts. The TF must plan local counterattacks to isolate and destroy any enemy that manages to penetrate through a gap in the AO. The commander should also plan to reposition units not in contact to mass the effects of combat power against an attacking enemy.

(b) The need for flexibility through the mobility of mechanized forces requires graphic control measures to assist in command and control during local counterattacks and repositioning of forces. Specified routes, phase lines, attack-by-fire positions, engagement areas, target reference points, and other fire control measures are required for the effective synchronization of maneuver.

(3) **Positioning the Reserve.** The commander must designate and position the reserve in a location where it can effectively react to several contingency plans. He must consider terrain, trafficability of roads, potential engagement areas, probable points of enemy penetrations, and commitment time. The commander may have a single reserve under TF control, or, if the terrain dictates, the company teams may designate their own reserves. The reserve should be positioned outside the enemy's direct fire range in a covered and concealed position. Information concerning the reserve may be considered EEFI and protected from enemy reconnaissance. The commander may choose to position his reserve forward initially to deceive the enemy or to move the reserve occasionally in order to prevent it from being targeted by enemy indirect fires.

(a) The size of the reserve depends upon the size of the area covered in the defense and the clarity of expected enemy action. The TF may need to defend an AO so large that only local reserves are feasible due to reaction time and the number of potential enemy COAs. The brigade reconnaissance troop, in conjunction with the scout platoon and other ISR assets, should be able to clarify enemy intentions by gathering intelligence on the massing of forces, electronic signals, and troop movement. This intelligence leads to situational understanding and allows the commander to better focus his efforts toward the size and task organization of the reserve.

(b) The TF commander must give specific planning guidance to the reserve to include priority for planning. METT-TC may require that a TF commander designate a reserve that may be called upon to accomplish tasks that include focusing on the MBA and responding to other missions necessary to assist the TF in accomplishing its mission. The reserve retains flexibility through offensive action. To generate larger ground maneuver reserves, the TF commander will have to redirect company or platoon

committed elements after they have accomplished their initial tasks or when the enemy's defeat frees them for other tasks.

(c) The speed, agility, and digitization at the unit level allow platoons, and sometimes companies, to be committed, withdrawn, redirected, and recommitted during the fight. This use of the reserve requires the best possible situational understanding and a COP that is constantly updated with accurate enemy intelligence. Moving a unit from one area (left to right or front to rear) requires each soldier in the unit to know where he is as well as where both the enemy and friendly forces are located.

(d) Additionally, the movement of ground forces over the distances expected in the expanded battlespace requires time. The time and distance (TDIS) relationship, especially under limited visibility conditions and rough terrain, is a key factor in determining which of the TF units can realistically be considered for a reserve mission that will require a great deal of flexibility in accomplishing multiple missions.

(e) During preparation of the TF defense, the TF reserve may conduct other tasks. The TF commander may initially position his reserve in a forward location to deceive the enemy, obscure subordinate boundaries, or show strength in an area where he intends to accept risk. The reserve may initially serve in the TF's forward security area and provide area security for the logistics sites or unoccupied areas of the TF's AO. However, the TF commander must consider the impact of these types of missions on his reserve force's ability to prepare for its critical role as the reserve during the MBA engagement.

(f) The commander of the TF reserve should also expect to receive specific decision points and triggers for employment on each contingency. This allows the reserve commander to conduct quality rehearsals and to anticipate his commitment as he monitors the fight.

(4) **Fire Support.** The TF does not possess organic fire support and may have to rely on TF mortars until DS artillery is available. The following are considerations for the fire support plan:

- Allocate initial priority of fires to the forward security force.
- Plan targets along enemy reconnaissance mounted and dismounted avenues of approach.
- Engage approaching enemy formations at vulnerable points along their route of march with indirect fires and CAS, if available.
- Plan the transition of fires to the MBA fight.
- Develop clear triggers to adjust fire support coordination measures and priority of fires.
- Ensure integration of fires in support of obstacle effects.
- Ensure integration of fires with TF counterattack plans and repositioning contingency plans.

(5) **Engineer Support.** The transition to countermobility and survivability requires detailed planning at the TF level in order to ensure subordinate engineers have adequate time for troop-leading procedures. (Refer to Section VI for a detailed discussion of mobility, countermobility, and survivability planning factors.) The following are key considerations:

- Sight situational obstacles early. Plan multiple locations to support depth and flexibility in the defense. Ensure adequate security for obstacle emplacement systems. Integrate triggers for execution of situational and reserve obstacles in the decision support template.
- Focus the countermobility effort to shape the enemy's maneuver into positions of vulnerability.
- Ensure adequate mobility support for withdrawing security forces, the reserve, and repositioning of MBA forces.
- Ensure integration of survivability priorities for critical systems and units.

(6) **Air Defense Support.** Key factors the TF must consider for air defense planning include the following:

- Position ADA assets and radars along air avenues of approach to provide early detection and engagement of enemy aircraft; defeat enemy air before it enters the MBA.
- Provide all-round air defense protection to the brigade with mutual supporting and overlapping fires. Weight fires toward likely air avenues of approach.
- Plan primary, alternate, and supplementary firing positions to support defensive positions in depth, delays, and counterattacks.
- Reposition ADA assets to replace lost assets or to mass against significant air threats.
- Ensure adequate security, survivability support, and CSS (especially missile caches) for ADA assets.
- Establish priorities of air defense protection based on the criticality, vulnerability, and recuperability of units and the enemy.
- Expect the enemy to employ heavy air attacks against critical friendly positions (BPs and SPs) to support a breakthrough of the brigade's defense.
- Protect the reserve, which has a critical role in the defense. The enemy will attempt to identify and target it to prevent its decisive employment.
- Protect C2 assets. They are normally stationary and produce a high electronic signature; thus, they are more susceptible to identification and targeting by enemy air attacks. C2 assets normally receive incidental area coverage provided by ADA assets protecting forward maneuver forces.
- Protect logistics units. They are normally stationary and located near roads and therefore are easily identified from the air.

(7) **Aviation Support.** In defensive operations, the speed and mobility of aviation can help maximize concentration and flexibility. During preparation for defensive operations, aviation units may support the TF commander with aerial reconnaissance and fires.

(a) During the defense, aviation fires can attack deep against high-payoff targets, enemy concentrations, and moving columns, and they can disrupt enemy centers of gravity. Attack helicopter TFs can be employed in depth to attack follow-on echelons before they can move forward to the close battle. Aviation forces may also conduct screening operations and may conduct guard operations of an open flank in conjunction with ground forces.

(b) Attack helicopters routinely support security area operations and mass fires during the MBA fight. Synchronization of aviation assets into the defensive plan is important to ensure aviation assets are capable of massing fires and to prevent fratricide. Detailed air-

ground integration and coordination is necessary to ensure efficient use of aviation assets (see Appendix B). If the TF is assigned aviation assets, it must give careful consideration to EA development and involve the direct fire planning and the supporting aviation unit, through its aviation LNO, in the planning process.

(8) **Nuclear, Biological, and Chemical Support.** Plan for NBC reconnaissance at likely locations for enemy employment of chemical agents. Use smoke to support disengagement or movement of forces.

(9) **Combat Service Support.** Plan primary and alternate MSR to support the full depth of the defense. Coordinate MSRs to avoid interfering with maneuver or obstacle plans. Specify routes for contaminated equipment movement. Also, consider the use of prestocked classes of supply (Classes IV and V) within the defense.

(10) **Health Services Support.** Health service support considerations for defensive operations include-

- Enemy actions and the maneuver of combat forces complicate forward area patient acquisition.
- Medical personnel are permitted much less time to reach the patient, complete vital EMT, and remove him from the battle site.
- Heaviest patient workloads, including those produced by enemy artillery and NBC weapons, can be expected during the preparation or initial phase of the enemy attack and in the counterattack phase.
- The enemy attack can disrupt ground and air routes and delay evacuation of patients to and from treatment elements.
- The depth and dispersion of the defense create significant time and distance problems for evacuation assets.
- The enemy exercises the initiative early in the operation, which could preclude accurate prediction of initial areas of casualty density. This fact makes the effective integration of air assets into the MEDEVAC plan essential.

(11) **Civilian Concerns.** Consideration of the higher headquarters rules of engagement (ROE) and limitations is necessary, particularly civilian effects and restrictions on fires and types of weapons. Regardless of whether civilians are removed from the area or protected in their homes, their movement and protection is a concern to the TF. In some cases, the TF may have to arrange for supply, transportation, and medical care for civilians.

(a) Restrictions may exist regarding use of cluster munitions, mines, nonlethal gas, smoke, and even mortar fires. Firing into towns or in the vicinity of refugees may be prohibited. Historical and cultural features may be protected. All of this can influence the design of the defense.

(b) Consider the availability of civilian assets and any limitations on use, including--

- Law enforcement support.
- Movement control.
- Transportation assets.
- Preclusion of area damage.
- Telecommunications security.
- Emergency supplies.

- Medical support.
- Decontamination support.

d. **Preparation.** During preparation, the commander and staff monitor preparatory actions and track the higher and adjacent unit situations and the enemy situation. They must update and refine plans based on additional reconnaissance and updated intelligence information. They conduct much of the preparation phase simultaneously with security operations, continuing even as forward-deployed forces gain contact with the enemy. Throughout the preparation phase, the TF commander, company team commanders, and key staff members should physically inspect preparatory activities. Weapons positioning, obstacle siting, direct and indirect fire plans, CSS operations, and soldiers' knowledge of their missions are all critical checks.

(1) **Rehearsals.** The TF and subordinate units should conduct rehearsals to practice their defense against multiple enemy COAs. The type of rehearsal executed must consider time, preparation activities, and OPSEC. Rarely will the TF be able to conduct a full-force rehearsal given the tempo of operations and the potentially large size of the AO. It may be better for key leaders to conduct a map or terrain board rehearsal at night in a command post or tent in order to focus their attention during daylight on inspecting preparations and working with subordinate leaders. The rehearsal should cover--

- Reconnaissance and security operations.
- Battle handover and passage of lines.
- MBA engagement.
- Reserve employment options.
- Actions to deal with enemy penetrations, major enemy efforts along areas of risk or flank avenues of approach.
- CSS operations, particularly casualty evacuation, emergency resupply operations, and reorganization.
- Execution of follow-on missions to exploit defensive success.
- Integration of aviation assets, if available.

(2) **Monitoring Preparation.** As subordinate units position their elements and execute defensive preparations, the TF staff monitors and coordinates their activities and the overall situation.

(a) The S2 closely monitors the enemy situation and focuses on indicators that reveal the enemy's likely time and direction of attack. The staff continually analyzes this assessment to determine the effects on preparation time available. The commander must update his PIR as the situation changes and be prepared to adjust the reconnaissance effort to answer those questions.

(b) The S3 closely monitors the status of rehearsals and updates the plan as needed based on continuously updated intelligence and the status of preparations.

(c) The XO analyzes the status of logistics and maintenance of equipment within the TF to determine any required adjustments to the plan or task organization.

(d) The engineer officer monitors the progress of all engineer efforts within the AO. He continually projects the end state of this effort based on the current and projected work rates. He must identify potential shortfalls early and determine how to shift assets to make up for the shortfall or recommend where to accept risk.

(e) As the enemy closes on the TF's AO, the TF begins final preparations that typically include--



- Final coordination for battle handover and passage of lines.
- Positioning of situational obstacle employment systems.
- Verification of communications status.
- Evacuation of unused Class IV and V (obstacle materiel and ammunition) to prevent capture or loss to enemy action.
- Withdrawal of engineer forces from forward areas.
- Linkup of CS and CSS assets with reserve or other supported combat forces (if not previously accomplished).
- Review of reconnaissance plan to ensure it still meets the commander's PIR.
- Final positioning or repositioning of reconnaissance assets, security forces, and observers.
- Positioning of teams to close lanes in obstacles or execute reserve obstacles.
- Execution of directed, reserve, or situational obstacles.
- Periodic situation updates and issuing of final guidance to subordinates.

This time may also be used to register indirect fire targets with mortars, if not already done. The commander may also conduct a final radio, digital, or even map rehearsal with key leaders.

(3) **Security Area Actions.** Once security area forces have moved into sector, actions in the security area predominantly focus on reconnaissance, counterreconnaissance, target acquisition, reporting, delay of the enemy main body, and battle handover. The task force's security area forces must integrate their actions with friendly forces forward of them, maintaining information flow and security. The task force's elements may have to execute battle handover with those forward elements and assist them in executing a rearward passage. This is especially likely if the fire elements are assets other than the brigade reconnaissance troop, which must move through the task force area to recover and prepare for another mission. Similarly, the security area forces must coordinate and cross-talk with the teams to their rear. Eventually, they must execute a rearward passage or move to the flanks of the main battle area. On approaches that the enemy does not use, it is usually advantageous to leave elements of the security force forward to preserve observation and access to enemy flanks.

(4) **Reconnaissance.** The purposes of the reconnaissance effort in the security area are to provide the commander with information to support his decision-making, to provide early warning and reaction time, and to support target acquisition. Guided by the commander's CCIR, the ISR plan, and the fire support plan, reconnaissance assets provide information that includes--

- Location, movement, and destruction of reconnaissance assets.
- Speed, direction, composition, and strength of enemy formations.
- Locations of high-payoff targets such as artillery and rocket units, bridging assets, and C2 nodes.
- Enemy actions at decision points.
- Enemy flanking actions, breaching operations, force concentrations, and employment of combat multipliers.
- Battle damage assessment.
- Movement of follow-on forces.

(a) The staff must integrate the information provided by the security forces with information received from higher and adjacent units, other subordinates, and sources such as JSTARS and UAVs.

(b) The total reconnaissance effort must support the commander's decision-making. In an area defense, the commander's critical decisions normally include--

- Initiation and employment of fires against enemy formations.
- Modifications or adjustments to the defensive plan.
- Execution of situational obstacles.
- Withdrawal of forward security forces.
- Commitment of the reserve, counterattack, or both.

(c) The TF commander establishes the criteria for the battle handover prior to the MBA fight, including where it will pass through, and designates routes and contact points. The handover is normally forward of the FEBA where elements of the reconnaissance unit are effectively overwatched by direct fires of the forward combat elements of the TF. The TF insures coordination is conducted with the reconnaissance unit and the TF's company and or team commanders that will be directly involved in the passing of the reconnaissance elements. This coordination is best established as an SOP to facilitate rapid accomplishment. Coordination normally includes--

- Establishing communications.
- Providing updates on both friendly and enemy situations.
- Coordinating passage.
- Collocating C2.
- Dispatching representatives to contact points and establishing liaison.
- Establishing recognition signals.
- Checking status of obstacles and routes.
- Establishing FS, air defense, and CSS requirements.
- Defining exact locations of contact points, lanes, and other control measures.
- Synchronizing actions to assist the reconnaissance element's rearward passage of lines in or out of contact.

(5) **Battle Handover.** The battle handover is the transfer of responsibility for the battle from the brigade's security area elements to the TFs. The higher commander who established the security force prescribes criteria for the hand over and designates the location where it will pass through, routes, contact points, and the battle hand over line. The battle hand over line is normally forward of the FEBA where the direct fires of the forward combat elements of the TFs can effectively overwatch the elements of the passing unit. The brigade commander coordinates the battle hand over with the TF commanders. This coordination overlaps with the coordination for the passage of lines, and the two should be conducted simultaneously. Coordination normally includes--

- Establishing communications to include ensuring linkage on the tactical internet and effective data overlap (ensuring elements in different units can see each other in the COP).
- Providing updates on both friendly and enemy situations facilitated through the addition of appropriate command posts and leaders to the message groups on situation reports and updates.

- Coordinating passage, which includes identifying passage points and lanes and exchanging or disseminating digital graphics of these and obstacle overlays. If either unit is not equipped with FBCB2, the coordination requires traditional passage of lines procedures.
- Collocating C2. This is not required if both units are digital, but it is desirable.
- Dispatching representatives to contact points and establishing liaison. If the passing unit is not FBCB2-equipped, the stationary unit should provide digital escorts to gain limited information of the passing unit.
- Coordinating recognition signals.
- Reporting status of obstacles and routes, including digital overlays.
- Coordinating fire support, air defense, and CSS requirements, giving particular attention to casualty and equipment evacuation requirements.
- Coordinating actions to assist the security force with breaking enemy contact.
- Coordinating and exchanging maneuver, obstacle, and fire plans.
- Coordinating location of and communications means to any stay-behind elements. These must be integrated into fire support coordination measures to establish no-fire areas (NFAs).

(a) Within the TF, the battle handover between the TF security elements and the company teams is far less formal or complicated. Elements must identify rearward passage points and lanes, and the passing elements need to coordinate their movement with the team(s) covering them and through which they are moving. Frequently, the first elements to displace are the maneuver forces that were executing counterreconnaissance, moving to initial defensive positions in the MBA, or acting as the TF or brigade reserve. The scout platoon normally displaces to vantage points on the flanks, moves to establish surveillance on other avenues of approach, or infiltrates to other areas in the TF AO.

(b) When battle handover occurs within the TF, the MBA teams--

- Assist passage of lines and disengagement.
- Gain and maintain contact with enemy forces as battle handover occurs.
- Maintain security.
- Close lanes, execute reserve obstacles, and emplace situational obstacles in the security area as the passing force withdraws.

(6) **Security Area Engagement.** Engagements in the TF security area are normally limited. Counterreconnaissance forces focus on locating and destroying enemy reconnaissance elements. As the enemy closes into the area, observers initiate indirect fires and execution of situational obstacles. The focal points are normally early warning and identification of the enemy main and supporting efforts in order for the commander to make decisions and position forces.

(7) **Main Battle Area Engagement.** The defensive battle is decided in the MBA by the actions of the TFs and company teams and their supporting CS and CSS units.

(8) **Maneuver.** During the MBA engagement, the brigade and TFs shift combat power and priority of fires to defeat the enemy's attack. This may require--

- Adjustment of subordinates' AOs and missions.
- Repositioning of forces.
- Shifting of the main effort.

- Commitment of the reserve.
- Modification of the original plan.

(a) Forward forces, obstacles, and fires within the MBA normally break the enemy's momentum, reduce his numerical advantage, and force his troops into positions of vulnerability. The TF masses fires (direct and indirect) to destroy attacking enemy forces as they enter the engagement areas.

(b) Depending on the defensive scheme, the TF may conduct delay operations, capitalizing on movement and repeated attacks to defeat the enemy, or it may fight primarily from a single series of positions.

(9) **Cohesion.** The TF must maintain a cohesive defense if it is to remain viable. This does not mean, however, that the forces must be massed close together. Company teams can maintain cohesion with forces dispersed by maintaining tactical cross-talk among subordinates and continual tracking and digital reporting of the enemy. The staff and commanders must continually assess the enemy's options and movement while identifying means to defeat them. With forces widely dispersed, continual assessment of time, distance, and trafficability factors is essential. To maintain defensive cohesion, company team commanders must keep their movement, positioning, and fires consistent with the commander's defensive scheme.

(10) **Threats to Task Force Logistics Sites.** During the MBA fight, protection of logistics sites is necessary to ensure freedom of maneuver and continuity of operations. Because allocating forces against threats to TF logistics sites diverts combat power from the MBA, the commander carefully weighs the need for such diversions against the possible consequences to the overall operation. To make such decisions wisely, the commander requires accurate information to avoid late or inadequate responses and to guard against overreacting to exaggerated reports.

(a) Generally, the TFSA and combat trains rely on positioning, movement, and self-protection for survival. Establish CSS operations in covered and concealed areas away from likely enemy avenues of approach. Establish and maintain perimeter security and early warning OPs, integrating weapons and crews that are in the rear for repair operations. Keep CSS nodes postured to move on very short notice as the security battle begins.

(b) Early warning to CSS units in the rear is critical to their survival in the event of a penetration of the MBA or enemy attack from an unexpected area. CSS plans and rehearsals must address actions to be taken in the event of an attack, including defensive measures, displacement criteria, routes, rally points, and subsequent positions to which to move.

(11) **Penetrations.** Unless the brigade plan makes other provisions, each TF commander is responsible for controlling enemy advances within his AO. If the enemy penetrates the defense or a penetration appears likely, the TF commander repositions forces or commits his reserve to block the penetration or to reinforce the area where a penetration appears imminent. Simultaneously, the TF commander allocates all indirect fires to support the threatened area. Additionally, he must alert the brigade commander to the threat and advise that he has committed his reserve force (if applicable). The TF commander may have to commit his engineers to assist in containing the penetration or constitute a new reserve from the engineers.

(a) If a penetration threatens the TF, the brigade commander may take several actions to counter the situation. In order of priority, he may do any or all of the following:

- Allocate priority of all available indirect fires, to include CAS, to the threatened unit. This is the most rapid and responsive means of increasing the combat power of the threatened unit.
- Direct or reposition adjacent units to engage enemy forces that are attacking the threatened unit. This may not be possible if adjacent units are already decisively engaged.
- Commit the brigade reserve to reinforce the threatened unit.
- Commit the brigade reserve to block, contain, or destroy the penetrating enemy force.
- Accept penetration of insignificant enemy forces and maintain contact with them as they move deeper into the MBA.

(b) When a penetration occurs, units within the MBA continue to fight, refusing their flanks and engaging the enemy's flanks and rear. The penetrated force must attempt to hold the shoulders of the penetration to prevent the area of penetration from widening and to protect adjacent unit flanks. Adjacent units must take immediate action to secure their exposed flanks, which may include security missions or the establishment of blocking positions. Adjacent units may also need to reposition forces, readjust subordinate AOs and tasks, or commit their reserve. MBA forces attempt to reestablish contact across the area of penetration when possible.

(12) **Counterattack.** The TF may conduct local counterattacks to restore or preserve defensive integrity. Unless defensive operations have left the TF largely unscathed, the TF usually lacks the ability to conduct a significant counterattack by itself. Within the context of the brigade's operations, a defending TF may execute a counterattack in support of the brigade's defensive posture, as part of a larger force seeking to complete the destruction of the enemy's attack, or as part of a transition to offensive operations.

(13) **Defense of an Extended Area of Operations.** With situational dominance, air superiority, and access to dynamic obstacles and extensive long-range fire support, the brigade can defend in a greatly enlarged AO. When it does so, the TFs defend as semi-independent entities, aware of their surroundings in great detail and supported with responsive fires and military intelligence (MI) assets but without direct contact with one another and beyond the immediate support of reserve forces. Essentially, these operations are area defenses with exceptionally low force-to-space ratios.

(a) TFs defending in extended AOs base their operations on superior intelligence, tactical agility, long-range fires, and continuous freedom of action. Based on a defensive concept that clearly divides responsibilities between brigade headquarters and the TFs, they employ massed long-range fires and other combat effects to immobilize, disorganize, and destroy enemy forces across a broad area. Close combat in these operations is limited to short, violent counterattacks or direct fire ambushes against damaged, vulnerable fragments of the enemy's force.

(b) TF maneuver plans for defense in an extended AO resemble delays: their commander's position company teams to deny key terrain, to observe the enemy at long range, and to move as necessary to attack the enemy with long-range fires while preserving their freedom of action. Rather than consistently withdrawing under pressure, however, the TF advances, displaces laterally, and withdraws as the enemy loses forces

or gains ground. The TF may use routes, phase lines, areas of operation, and directions of attack to control the movement of company teams and platoons.

(c) The brigade and division staffs must assure that TFs defending in this manner maintain a highly accurate view of the enemy, the environment, and significant civilian factors. Some sensors and their downlinks may be directly assigned to the TFs for these operations. Elements of the brigade reconnaissance troop and division aviation assist the TFs in defending these large areas, assuming responsibility for specified enemy forces as the situation develops. Maintaining contact with the enemy and sustaining observation of every part of the AO is of special importance in a defense of this type. Losses of reconnaissance coverage demand immediate attention.

(d) A defense in an extended AO heavily tasks the TF fire support officer. His FISTs are widely separated and may require simultaneous high-priority support. Additionally, he commonly must coordinate CAS and attack helicopter support. The FSO's workload can be reduced by a concept of fire support that assigns a large part of the coordination responsibility to the brigade FSO, but he is also heavily tasked because of the brigade's expanded area of operations.

(e) The TF's understanding of the terrain, weather, and radio-electronic environment is crucial to its success. To exploit superior situational understanding, the TF must understand the mobility potential of the area and maintain current intelligence that confirms the status of obstacles and routes. The TF must anticipate changing weather and visibility conditions accurately and in time to adjust its dispositions without losing control of the defended area. It must foresee enemy air assaults or strikes against choke points in the depth of the defended area and account for them either by tactical counteraction or by strong air defense of vital points.

(f) Threats to communication also pose special problems for the TF when it defends in an extended AO. Digitized C2 assets are key to defending effectively in a large AO. Brigade and division signal officers must provide redundant radio networks to assure that current intelligence and orders reach the TF, which then distributes them to company teams. The TF must establish priorities for information transfer and command and control to allow it to continue operating if the signal system is impaired. Special means of assuring contact with all friendly forces--retransmission stations, relays, and additional radios--also merit attention in planning for operations in an extremely large AO.

(g) When defending in extended areas, the TF performs land management tasks in many cases that are more typical of brigade operations. Positioning sensors, forward arming and refueling points (FARPs), FA systems, aid stations, CSS collection and supply points, and command posts far enough forward to function may necessitate positioning them in the TF AO. While the TF should not be required to defend such sites, it must follow their movements and clear their occupation of positions.

(h) The CSS effort also demands special planning and nearly flawless execution. The distances between company teams, mortar positions, command posts, and other TF elements adds considerably to the time necessary to move supply, maintenance, and medical support teams. Moving logistical elements over those distances consumes more fuel and parts and calls for CSS leaders who can move quickly and adapt to friendly maneuver while en route across open spaces between units. Planners must provide for emergency resupply of fuel and ammunition, and TF elements must be trained to receive it.

(i) Medical evacuation assumes special importance because of the moral imperative of caring for wounded soldiers and the difficulty inherent in widely dispersed operations. In some cases, defending over extended frontages and depths requires that additional medical augmentation units or elements be positioned with those units inside the TF AO.

(j) Transitioning from defense of an extended area to a smaller AO requires reinforcement of the TF or narrowing of its AO.

(k) Transitioning to the offense depends on defeating the enemy decisively and recognizing that defeat promptly. The brigade commander must provide the planning and warning that precedes these transitions. TF and company team commanders must be ready to confirm sensor indications of enemy condition and to recommend transition to the offense as they sense the enemy's defeat.

## 6-5. MOBILE DEFENSE

The mobile defense concentrates on the destruction or defeat of the enemy through a decisive counterattack. The focus is on defeating or destroying the enemy by allowing him to advance to a point where he is exposed to a decisive counterattack by the striking force. The striking force is a dedicated force composed of the bulk of the combat power and weighted with the majority of the available combat multipliers. A fixing force shapes the battlefield and the enemy, setting the conditions for the striking force.

a. **Depth.** A mobile defense requires considerable depth in the area of operations in order for the commander to shape the battlefield, causing the enemy to extend his lines of communication and support, expose his flanks, and dissipate his combat power. The terrain must allow the commander to maneuver to attack an enemy flank or rear. A division or corps most frequently conducts a mobile defense, but the brigade is also capable of doing so.

b. **Fixing Force.** TFs participate in a brigade mobile defense as an element in a fixing force conducting a delay or area defense or as an element of a striking force conducting offensive operations. (See Chapter 5 for a discussion on offensive operations.) The TF most often conducts a force-oriented attack against a stationary enemy that the area defense and reserve has stopped. The TF might conduct a force-oriented attack against a moving enemy if the area defense cannot stop the enemy's advance. During these attacks, the TF might act as the security force, main body, or reserve.

## 6-6. RETROGRADE OPERATIONS

The retrograde is a type of defensive operation that involves organized movement away from the enemy (FM 3-0 and FM 3-90). The enemy may force these operations or a commander may execute them voluntarily. In either case, the higher commander of the force executing the operation must approve the retrograde (FM 3-90.3). Retrograde operations are conducted to improve a tactical situation or to prevent a worse situation from developing. TFs normally conduct retrogrades as part of a larger force but may conduct independent retrogrades as required, such as when conducting an area or point raid. In either case, the TF's higher headquarters must approve the operation.

- a. Retrograde operations accomplish the following:
- Resist, exhaust, and defeat enemy forces.
  - Draw the enemy into an unfavorable situation.

- Avoid contact in undesirable conditions.
  - Gain time.
  - Disengage a force from battle for use elsewhere in other missions.
  - Reposition forces, shorten lines of communication, or conform to movements of other friendly units.
- b. The three forms of retrograde operations are--
- **Delay.** This operation trades space for time and preserves friendly combat power while inflicting maximum damage on the enemy.
  - **Withdrawal.** A withdrawal is a planned, voluntary disengagement from the enemy, which may be conducted with or without enemy pressure.
  - **Retirement.** A retirement is an operation in which a force that is not in contact with the enemy moves to the rear in an organized manner.

**NOTE:** Maintenance of morale is essential among subordinate leaders and troops in a retrograde operation. Movement to the rear may seem like a defeat or a threat of isolation unless soldiers have confidence in their leaders and know the purpose of the operation and their roles in it.

## 6-7. DELAY

In a delay, the TF trades space for time and inflicts maximum damage on the enemy while avoiding decisive engagement at the TF level. It is critical that the commander's intent defines what is more important in the mission--time, damage to the enemy, or force protection. Inflicting damage is normally more important than gaining time. The brigade commander establishes risk levels for each delay but maintaining freedom of action and avoiding decisive engagement are ordinarily of ultimate importance. The brigade may execute a delay when it has insufficient combat power to attack or defend or when the higher unit's plan calls for drawing the enemy into an area for a counterattack, as in a mobile defense. Delays gain time to--

- Allow other friendly forces to establish a defense.
  - Cover a withdrawing force.
  - Protect a friendly force's flank.
  - Allow other forces to counterattack.
- a. **Forms of Delay.** Based upon the commander's intent and METT-TC, the two types of delay missions are: delay within an area of operations or delay forward of a specific control measure.
- (1) **Delay within an Area of Operations.** The TF may be assigned a mission to delay within an area of operations. The higher commander normally provides guidance regarding intent and desired effect on the enemy, but he minimizes restrictions regarding terrain, time, and coordination with adjacent forces. This form of a delay is normally assigned when force preservation is the highest priority and there is considerable depth to the brigade or division's area of operations.
- (2) **Delay Forward of a Specified Line for a Specified Time.** The TF may be assigned a mission to delay forward of a specific control measure for a specific period of time. This mission is assigned when the brigade or TF must control the enemy's attack and retain specified terrain to achieve some purpose relative to another element, such as setting the conditions for a counterattack, for completion of defensive preparations, or for



the movement of other forces or civilians. The focus of this delay mission is clearly on time, terrain, and enemy destruction. It carries a much higher risk for the TF, with the likelihood of all or part of the unit becoming decisively engaged. The timing of the operation is controlled graphically by a series of phase lines with associated dates and times to define the desired delay-until period.

b. **Culmination of the Delay.** Delay missions usually conclude in one of three ways--a defense, a withdrawal, or a counterattack. Planning options should address all three possibilities.

## **6-8. DELAY ORGANIZATION**

The TF's organization of its forces depends on how the brigade has structured its forces (unless the TF operates independently). The brigade normally organizes into a security force, main body, and reserve, but a wide AO may preclude the use of brigade-controlled security forces and reserves. In this case, the brigade may direct the TF to organize its own security, main body, and reserve forces--the same as if the TF were operating independently. The brigade commander can designate a TF as the security or reserve force for the brigade. If the TF has to establish a security force, it normally uses the scout platoon as a screen force positioned to observe the most likely enemy avenues of approach and to initiate indirect fires to slow and weaken the enemy. Initially, the TF main body usually locates well forward in the AO, then fights from a series of subsequent positions. The reserve force, normally one or two platoons, is used to defeat enemy penetrations or to assist units with breaking contact.

## **6-9. DELAY PLANNING CONSIDERATIONS**

The delay requires close coordination of forces and a clear understanding by subordinates of the scheme of maneuver and commander's intent. The potential for loss of control is very high in delay operations, making cross-talk and coordination between subordinate leaders extremely important. Subordinate initiative is critical, but it must be in the context of close coordination with others. Plans must be flexible, with control measures throughout the AO allowing forces to be maneuvered to address all possible enemy options.

a. **General Considerations.** The commander determines the end state of the delay based on the higher commander's intent and specific parameters of the higher headquarters' delay order. The commander considers the factors of METT-TC, especially the effects of the terrain, to identify advantageous locations from which to engage the enemy throughout the depth of the AO. Specific delay planning considerations the commander and staff must determine include--

- Force array and allocation of combat multipliers, particularly fires and obstacles.
- Where and when to accept decisive engagement.
- Acceptable level of risk for each subordinate force.
- Form of delay and control measures (company teams delay in AO, control by battle positions, or some other method).
- Integration of obstacle intent and EFSTs.
- Likely subsequent mission, transition point(s), and conditions.

b. **TF Order.** The TF order must clearly articulate the parameters of the delay mission. The following is an example of a delay mission issued to a subordinate TF.

**EXAMPLE:** TF 3-6 delays forward of PL Blue (*space*) until 010400 Sep XX (*time*) to allow the remainder of the brigade to complete defensive preparations (*why*).

c. **Effects of Terrain.** The staff analyzes the effects of terrain and the anticipated enemy situation to identify positions that offer the best opportunity to engage, delay, and inflict damage on the enemy force. As the staff develops delay positions and control measures, it calculates enemy closure rates and compares them to friendly displacement rates between positions. Time and space factors dictate the amount of time subordinate units have to engage the enemy and move before becoming decisively engaged. The staff calculates these factors for each avenue of approach; it develops triggers for displacement to positions in depth.

d. **Enemy Vulnerabilities.** The staff analyzes the terrain and expected enemy situation to identify advantageous locations from which to engage the enemy at existing obstacles such as choke points or urban or complex terrain. It also considers possible locations to plan counterattacks. Situational and event templates must tell the commander and staff where the enemy is likely to be at certain times. This helps them decide where to emplace obstacles, where to mass fires, and if or where decisive engagement is likely or required.

e. **Maneuver Considerations.** The staff considers maneuver actions, fires, obstacles, and the employment of other supporting assets necessary to degrade the enemy's mobility and to support friendly forces' disengagement to subsequent positions. This is especially critical at locations and times when company teams or the entire TF may become decisively engaged with the enemy. As the staff develops and refines the plan, it develops decision points for key actions to include triggers for the employment of fires and situational or reserve obstacles; displacement of subordinate units to subsequent positions; and movement of indirect fire assets, C2 facilities, and CSS units. The staff also selects routes for reinforcements, artillery, CPs, and CSS elements to use and synchronizes their movements with the delaying actions of forward units.

## 6-10. DELAY SCHEME OF MANEUVER

The scheme of maneuver must allow the TF to dictate the pace of the delay and maintain the initiative. The commander selects positions that allow his forces to inflict maximum damage on the enemy, support their disengagement, and enable their withdrawal. He may choose to delay from successive or alternating delay positions depending on the strength of the teams and the width of the AO.

a. **Areas of Operations.** At brigade level, areas of responsibility are defined by establishing AOs for each TF and developing control measures to ensure adequate control while supporting decentralized freedom of action. The brigade normally assigns deep, parallel AOs to delaying TFs. Each enemy avenue of approach is assigned to only one subordinate unit. Boundaries are used to define TF AOs. When boundaries are drawn, terrain that provides fields of fire and observation into an area is assigned to the unit responsible for that AO or BP. The brigade commander may also use phase lines to

control the timing and movement of delaying units. Doing so constrains TF commanders to delaying on or forward of those lines at least until the specified time. Contact points and other control measures are established to support flank unit coordination. The commander and his staff make provisions for coordinated action along avenues of approach which diverge and pass from one subordinate AO to another.

b. **Control Measures.** The TF organizes its maneuver in a similar fashion. The TF commander may decide to add additional control measures, to include phase lines, battle positions, engagement areas, or attack by fire positions that allow the TF commander to direct the fight more closely and give subordinates a clearer picture of how he envisions fighting the delay.

c. **Delay Positions.** When determining the scheme of maneuver, positions should incorporate as many of the following characteristics as possible:

- Good observation and long-range fields of fire.
- Covered or concealed routes of movement to the rear.
- A road network or areas providing good cross-country trafficability.
- Existing or reinforcing obstacles to the front and flanks.
- Maximized use of highly defensible terrain.

#### **6-11. MAXIMIZING THE USE OF TERRAIN IN A DELAY**

Delay positions should be on terrain that controls likely enemy avenues of approach, allows engagements against the enemy where his movement is most canalized, and facilitates maximum delay with minimum forces. Long-range direct fires are highly desirable because they force the enemy to deploy and move carefully and because they reduce the likelihood of unintended decisive engagement of company teams and platoons. Integrating force positioning and movement with terrain, fires, and situational obstacles helps inflict maximum damage on the enemy while allowing friendly freedom of maneuver and disengagement. If not constrained by commander's guidance and rules of engagement, the cover and movement restrictions of urban areas should be extensively exploited if they cannot be readily bypassed.

#### **6-12. FORCING THE ENEMY TO DEPLOY AND MANEUVER IN A DELAY**

Engagement at maximum ranges of all weapons systems causes the enemy to take time-consuming measures to deploy, develop the situation, and maneuver to drive the delaying force from its position. An aggressive enemy commander will not deploy if he correctly determines that friendly forces are delaying; he will use his mass and momentum to develop sufficient pressure to cause friendly forces to fall back or become decisively engaged. Therefore, the delay must include the deadly integration of direct and indirect fires and situational obstacles to make the enemy doubt the nature of the friendly mission and leave him no choice but to deploy and maneuver.

#### **6-13. AVOIDING DECISIVE ENGAGEMENT IN A DELAY**

A key to a successful delay is to maintain a mobility advantage over the attacking enemy and avoid decisive engagement. The TF seeks to increase its mobility while degrading the enemy's ability to move.

- a. The TF improves its mobility by--

- Maintaining contact with the enemy, maintaining reconnaissance and security on flanks, and coordinating with adjacent units to prevent forces from being isolated.
  - Reconnoitering routes and BPs.
  - Improving routes, bridges, and fording sites between delay positions, as time and resources permit.
  - Using indirect fires and obstacles to support disengagement and to cover movement between positions.
  - Task-organizing and positioning breaching assets within subordinate formations to breach enemy scatterable mines rapidly.
  - Using multiple routes.
  - Controlling traffic flow and restricting refugee movements to unused routes.
  - Keeping logistical assets uploaded and mobile.
  - Caching ammunition on rearward routes and ensuring that units know the locations of these supply points (create a supply point icon in FBCB2). If possible, the supply point should be guarded and prepared for destruction if not used by delaying forces.
  - Task-organizing additional medical and equipment evacuation assets to the TFs to increase their ability to disengage and displace rapidly.
  - Positioning air defense assets to protect bridges and choke points on rearward routes.
- b. The TF degrades the mobility of the enemy by--
- Maintaining continuous pressure on the enemy throughout the area of operations.
  - Attacking logistics as well as maneuver and fire support assets.
  - Occupying and controlling choke points and key terrain that dominates high-speed avenues of approach.
  - Destroying enemy reconnaissance and security forces, which blinds the enemy and causes him to move more cautiously.
  - Engaging at maximum ranges.
  - Employing a combination of directed situational and reserve obstacles.
  - Employing indirect fires, smoke, and CAS, if available.
  - Using deception techniques such as dummy positions.

#### **6-14. PARAMETERS OF THE DELAY ORDER**

As previously noted in paragraph 6-9, an order for a delay mission must specify certain parameters.

a. **First Parameter.** First, it must direct one of two alternatives--delay throughout the depth of the AO or delay forward of a specific line or area for a specific period of time. A mission of delay within an AO implies that force integrity is a prime consideration. In this case, the TF delays the enemy as long as possible while avoiding decisive engagement. If the delaying force is ordered to hold the enemy forward of a given PL for a specified time, mission accomplishment outweighs preservation of the force's integrity. Such a mission may require the force to defend a given position until ordered to displace.

b. **Second Parameter.** The second parameter the order must specify is acceptable risk. Acceptable risk ranges from accepting decisive engagement in an attempt to hold terrain for a given period of time to avoiding decisive engagement in order to maintain the delaying force’s integrity. The depth available for the delay, the time needed by the higher headquarters, and subsequent missions for the delaying force determine the amount of acceptable risk.

b. **Third Parameter.** The order must specify whether the delaying force may use the entire AO or whether it must delay from specific BPs. A delay using the entire AO is preferable, but a delay from specific positions may be required to coordinate two or more units in the delay.

c. **Other Parameters.** The TF order and commander’s intent should define for the teams what the scheme of maneuver is, what the priorities are, and how much freedom the subordinate leaders have in maneuvering their forces. The TF commander usually gives a company team commander very little freedom, specifying constraints on maneuver and requirements for coordination, unless the company team is delaying on an avenue of approach that is essentially isolated. The TF commander defines the criteria for disengagement and movement to subsequent positions or areas and a series of battle positions, checkpoints, or phase lines from which, or forward of which, the company team must fight.

**6-15. ALTERNATE AND SUBSEQUENT POSITIONS IN A DELAY**

In planning, if the commander chooses to delay using battle positions, he can use either alternate positions or subsequent positions. In both techniques, the delaying forces maintain contact with the enemy between delay positions. Table 6-1 shows the advantages and disadvantages of the two techniques.

METHOD OF DELAY	USE WHEN:	ADVANTAGES	DISADVANTAGES
Delay from subsequent positions.	AO is wide. Forces available are not adequate to be positioned in depth.	Reduced fratricide risk. Ease of C2. Repeated rearward passages not required.	Limited depth to the delay positions. Easier to penetrate or isolate units. Less time available to prepare each position. Less flexibility.
Delay from alternate positions.	AO is narrow. Forces are adequate to be positioned in depth.	Allows positioning in depth. Harder for enemy to isolate units. More flexibility.	More difficult C2; requires continuous coordination. Requires passage of lines increasing vulnerability and fratricide potential.

**Table 6-1. Comparison of methods of delay.**

a. **Delay from Alternate Positions.** In a delay from alternate positions (Figure 6-4, page 6-26), two or more units in a single AO occupy delaying positions in depth. As the

first unit engages the enemy, the second occupies the next position in depth and prepares to assume responsibility for the operation. The first force disengages and passes around or through the second force. It then moves to the next position and prepares to reengage the enemy while the second force takes up the fight. Both the brigade and TF can use this scheme of maneuver. At the brigade level, if the AO is narrow, the brigade employs TFs in depth occupying alternate positions. This enables the brigade to develop a strong delay with forces available to counterattack or assist in the disengagement of the TF in contact. At the TF level, using alternate positions helps maintain pressure on the enemy and helps prevent platoons or company teams from being decisively engaged. A delay from alternate positions is particularly useful on the most dangerous avenues of approach because it offers greater security and depth than a delay from subsequent positions. However, it also poses the highest potential for fratricide and vulnerability as units pass through or near each other.

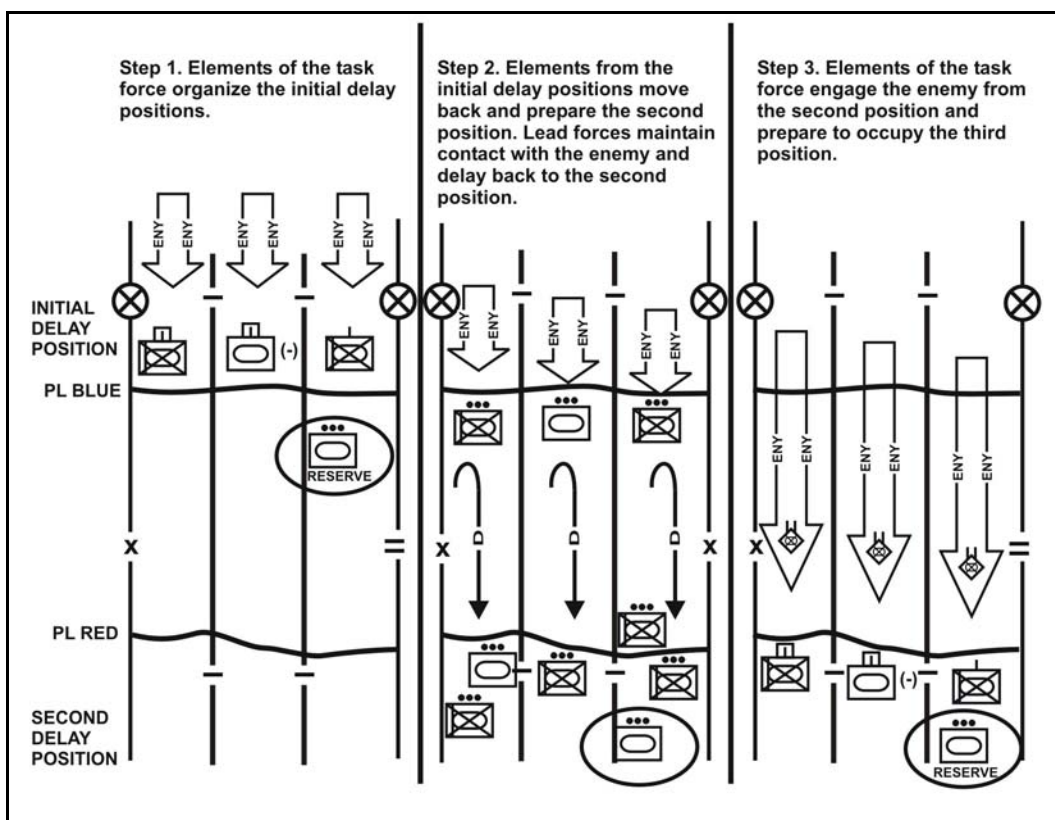


Figure 6-4. Delay from alternating positions.

b. **Delay from Subsequent Positions.** The TF uses a delay from subsequent positions (Figure 6-5) when the assigned AO is so wide that available forces cannot occupy more than a single tier of positions. This is the more common form of a delay operation given the expanded battlespace in which the brigade and TFs normally operate. In a delay from subsequent positions, the majority of forces are arrayed along the same PL or series of BPs. The forward forces delay the enemy from one PL to the next within their assigned AOs. At TF level, this is the least preferred method of delaying since there is a much higher probability of forces becoming isolated or decisively engaged,

particularly if the delay must be maintained over more than one or two subsequent positions. Additionally, the TF has limited ability to maintain pressure on the enemy as it disengages and moves to subsequent positions unless it has been allocated additional (and adequate) indirect fire support.

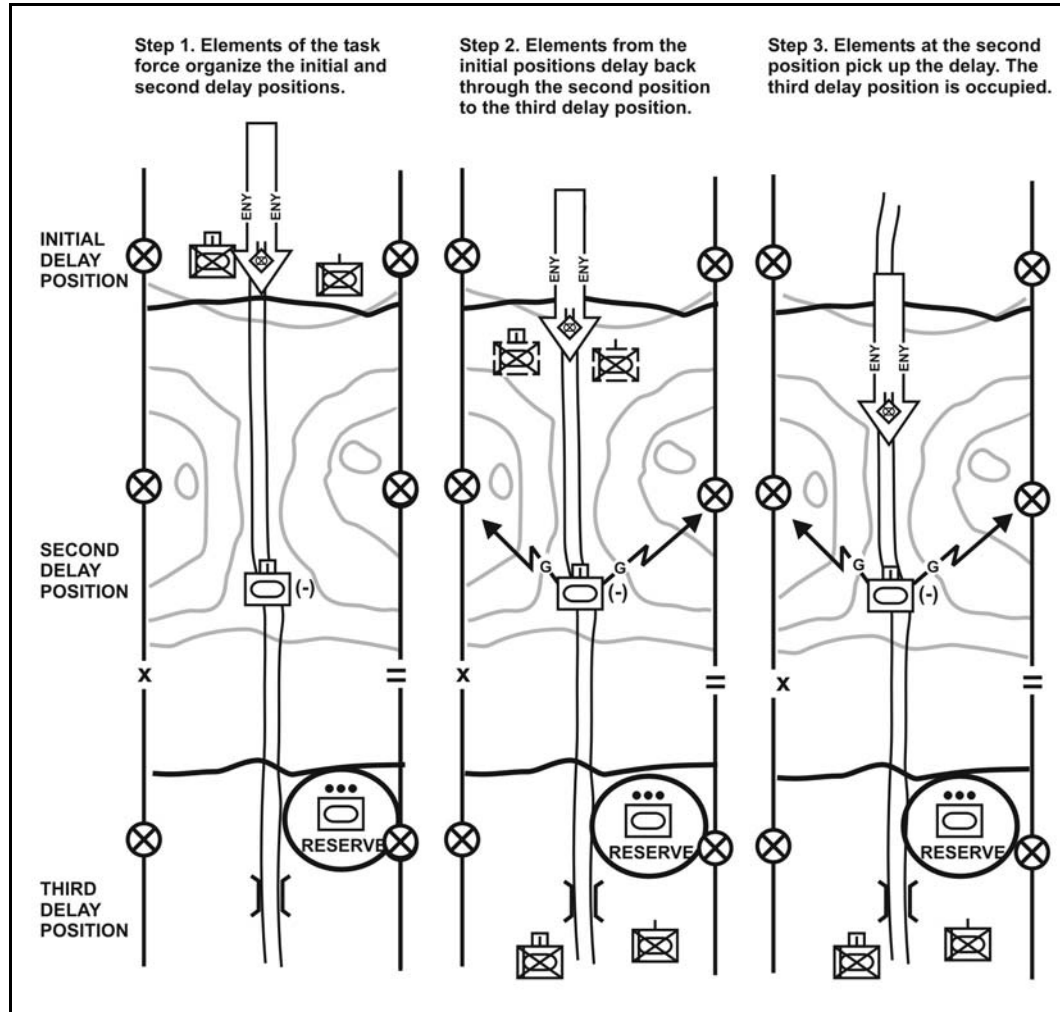


Figure 6-5. Delay from subsequent positions.

## 6-16. FIRE SUPPORT IN A DELAY

Key considerations for the fire support plan include--

- Attack the enemy throughout the AO.
- Engage the enemy with fires to inflict casualties and disrupt his approach before he reaches friendly delaying positions. Plan final protective fires (FPFs) for each series of delaying positions to support disengagement.
- Mass fires on high-payoff targets and canalizing terrain to limit the momentum of the enemy's attack.
- Ensure fires are tied to obstacles.
- Plan and designate priority targets along routes from one delaying position to the next.

- Mass all available fire support (lethal and nonlethal) to support disengagements.
- Use smoke to screen friendly movements and for deception.

#### **6-17. ENGINEER SUPPORT IN A DELAY**

Key considerations for the scheme of engineer operations include the following.

- a. When operating over a wide AO, task-organize countermobility assets to teams, decentralizing control and execution.
- b. Task-organize mobility assets to teams to support mobility requirements. Consider logistical requirements and support of CSS assets in task-organizing mobility assets.
- c. Develop the obstacle plan to support disengagement of delaying forces and to shape the enemy's maneuver to meet the commander's intent. Consider countermobility requirements for all delaying positions throughout the depth of the AO. Integrate SCATMINES at delay positions to support disengagement and movement to subsequent positions.
- d. Consider the impact of the obstacle effort on the movement of friendly forces and future operations. Develop obstacle restrictions, establish lanes and guides, and employ situational or reserve obstacles to support mobility requirements. Provide for closing lanes behind friendly forces with scatterable or hand-emplaced mines.
- e. Develop clear criteria for execution of situational and reserve obstacles. Integrate decisions for their execution in the decision support template.
- f. Construct survivability positions in depth, as required, to support repositioning forces.

#### **6-18. AIR DEFENSE SUPPORT IN A DELAY**

The following are key considerations for the air defense plan.

- a. Synchronize the movement and positioning of ADA assets with the delaying forces.
- b. Ensure adequate air defense coverage of friendly forces during movements from one delaying position to another. Consider protection along movement routes, choke points, and bridges that friendly forces intend to use.

#### **6-19. NUCLEAR, BIOLOGICAL, AND CHEMICAL SUPPORT IN A DELAY**

Brigade planning defines NBC operations in the delay. TFs may coordinate for NBC reconnaissance assets if available in the brigade. Decontamination operations in the delay focus on individual and crew operational decontamination procedures until the conclusion of the operation when thorough decontamination can be accomplished. If smoke generators are available, the TF may employ them for deceiving the enemy, obscuring movement and positions, or obscuring portions of the battlefield to reduce enemy visibility and ease of movement.

#### **6-20. COMBAT SERVICE SUPPORT IN A DELAY**

CSS for a delay is particularly complex. Maintaining communications within the CSS system, accurately tracking the battle, maintaining personnel accountability, and anticipating support requirements are especially important. Keeping the CSS assets



mobile and supplies uploaded is a key planning consideration. Other considerations include--

a. Providing HSS for the delay may also be difficult since enemy actions and the maneuver of combat forces complicate forward area acquisition of patients.

(1) Planning considerations for HSS should include--

- Positioning ambulances with each of the companies and requesting medical treatment and evacuation support from the FSMC as required.
- Integrating the evacuation routes with the obstacle plan.
- Marking CCPs and evacuation routes for day and night operations.
- Positioning treatment elements forward but to the rear of the maneuvering forces.
- Establishing alternate treatment sites with triggers to reposition.
- Planning for the use of both standard and nonstandard evacuation platforms.
- Rehearsing CASEVAC procedures to include standard and nonstandard platforms.
- Observing time and the means available to remove patients from the battlefield. In either a stable situation or in the advance, time is important only as it affects the physical well being of the wounded. In a delay, time is important. As available time decreases, the use of nonstandard evacuation platforms will increase and companies must be prepared to withdraw, moving their casualties with them.
- Integrating the effective use of air assets into the MEDEVAC plan is essential.

(2) Task-organize additional ambulances and recovery vehicles to the company teams. Request HETs to support rapid evacuation of damaged equipment.

b. Emphasize maintenance support forward with short evacuation times; use all available assets (to include firepower-damaged vehicles) to evacuate damaged vehicles to the rear. Battle damage assessment and repair (BDAR) is a procedure that can be used during a delay to rapidly return disabled equipment to the battlefield by expediently fixing, bypassing, or jury-rigging components. It also includes the use of cannibalization of equipment. It restores the minimum essential combat capabilities necessary to support a specific combat mission or to enable the equipment to self-recover. Crews, company maintenance teams, maintenance support teams, and recovery teams use BDAR. The commander establishes guidelines for BDAR in SOPs and combat orders. However, destruction of equipment may have to occur if time and evacuation capability are limited and the result would be that goods and equipment would become available to the enemy.

c. Synchronize refueling and resupply operations with the scheme of maneuver and the anticipated enemy situation to ensure continuity of support. Increase emergency Class III and V supplies positioned forward.

d. Do not coordinate for throughput too far forward, which might cause assets to be caught in the fight or to add to route congestion. Depending on the situation, this may not apply during the initial preparations for the delay.

e. Plan routes for CSS assets that do not conflict with maneuver elements.

## **6-21. DELAY PREPARATIONS**

Defensive preparations discussed in Section II also apply during the conduct of a delay.

a. **Inspections.** The commander inspects planning and preparations of his subordinate units to ensure--

- Maneuver, fire, and obstacle plans are consistent with his intent.
- Flank coordination between delaying teams is conducted to maintain cohesion and mutual support during the delay.
- Defensive preparations proceed according to established timelines.
- All leaders have a clear understanding of the scheme of maneuver and the commander's intent.

b. **Rehearsals.** When conducting a rehearsal for a delay, key leaders practice the operation against all feasible enemy COAs to promote flexibility of decision-making, plans, and execution. The commander examines each subordinate unit commander's plan as he fights the delay during the rehearsal and pays close attention to the following:

- Direct and indirect fire instructions.
- Timing of movements and delaying actions from one position to the next, with special attention paid to the disengagement criteria.
- Means and methods of disengaging from the enemy and maintaining contact with the enemy as the force moves to subsequent positions.
- Execution of situational and reserve obstacles to include closure of lanes.
- Movement times, routes, and positioning of CS and CSS assets.

The commander also rehearses plans to deal with potential reverses, enemy penetrations, and unanticipated decisive engagement. The rehearsal serves to synchronize further the movement of combat forces, CS, and CSS units. It is especially important to portray movement times and required routes realistically during the rehearsal to identify potential conflicts.

## 6-22. EXECUTION OF A DELAY

The TF moves key forces and support to prepare for the delay. This initial movement includes movement into the security area and MBA.

a. **Security Area Actions.** Normally, delaying forces occupy the FLOT without a security force to their front. If the brigade can create a security area force for a delay, the TF may position the scout platoon in a screen behind the brigade security force to maintain observation, provide early warning, and continue to observe for indirect fires to continue the disruption and attrition of the attacking enemy. As the enemy closes into and through the security area, the screening forces move back through or around the initial main body positions to subsequent positions that allow them to observe the main battle area and assist in the disengagement and movement of forces to their next positions.

b. **Main Battle Area Engagement.** The TF forces the enemy to deploy and attack by its use of fires and obstacles, massing effects quickly for a short period to inflict the maximum damage on the enemy at the maximum range. To avoid decisive engagement, the TF must disengage before the enemy can breach obstacles or mass effective fire on the delay position. Observers positioned to the flanks in depth continue to observe and shift indirect fires as forces delay to subsequent positions. Company teams may move by bounds within the TF or company team to maintain direct fires on the enemy and cover movement. Short, intense engagements at near maximum range with sustained indirect fires and covering obscurants are the key to successful delay operations.

c. **Controlling the Delay.** The TF commander must closely control the disposition, displacement, and maneuver of his forces in order to maintain the cohesion of the delay operation and keep the entire TF synchronized with the remainder of the brigade. FBCB2 represents a major advantage in force tracking. Given the potential for loss of positive control, it is critical that the commander clearly establish parameters for displacement.

(1) As it executes the delay, the TF and company team commanders must continually assess their situation and requirements to displace with the following considerations:

- What are the size, activity, and location of attacking enemy forces? Are elements of the TF threatened with decisive engagement or bypass?
- What is the status of adjacent units?
- What is the disengagement criteria?
- Are supporting assets, particularly artillery and mortars, postured to support movement? If not, how long will it take them to be ready?
- Are the obstacles supporting the present position still intact and effective?
- Are direct and indirect fires effective?
- How strong is this position in relation to other positions the force might occupy?
- What is the ammunition status?
- Are displacement routes clear?

(2) The TF must always make decisions about displacement and timing in the context of the commander's intent and priority for the delay (for example, is time more important than force preservation, or vice versa?). In many instances, the TF or elements of it must accept decisive engagement to execute the mission and then break contact as the situation permits or in conjunction with another force's counterattack.

d. **Counterattacks.** The TF can rarely execute a substantial counterattack during a delay by itself unless it is part of the larger brigade scheme of maneuver. Generally, counterattacks executed by the TF in its own scheme of maneuver are platoon- to possibly company-size counterattacks to support disengagement of forces or to destroy penetrations. Whenever possible, the brigade executes counterattacks to counter penetrations, to gain a temporary degree of initiative or freedom of action, and to avoid a predictable pattern of operation.

e. **Decisive Engagement.** The TF and company teams avoid becoming decisively engaged except when necessary to prevent the enemy from reaching a specified area too early or when a part of the force must be risked to protect the entire force. If elements of the TF are threatened with decisive engagement or have become decisively engaged, the commander may take actions to support their disengagement. In order of priority, he may do any of the following:

- Allocate priority of all supporting fires to the threatened unit. This is the most rapid and responsive means of increasing the unit's combat power.
- Employ CAS or attack helicopters to suppress the enemy and restore freedom of maneuver to the TF.
- Reinforce the unit. In a delay mission, particularly over a wide AO, the TF may not be able to do this quickly enough with ground maneuver forces.
- Conduct a counterattack to disengage the unit.

Once forces have become decisively engaged, they must not break contact without adequate measures by the TF to prevent the enemy from rapidly pursuing and destroying the force piecemeal.

f. **Terminate the Delay.** A delay mission ends with another planned mission such as a defense, withdrawal, or attack. Ideally, a brigade or TF that has been delaying conducts a rearward passage of lines through the established defense of another friendly force. The TF executes its actions in the context of the brigade's actions. If it defeats the enemy attack during the delay, the brigade may--

- Maintain contact while another force counterattacks.
- Withdraw to perform another mission.
- Transition to the offense.

In all cases, the commander must plan for the expected outcome of the delay based on the situation and the higher commander's plan.

### 6-23. WITHDRAWAL

Withdrawal is a planned operation in which a force in contact disengages from an enemy force. Withdrawals may or may not be conducted under enemy pressure. The two types of withdrawals are assisted and unassisted.

a. **Assisted.** The assisting force occupies positions to the rear of the withdrawing unit and prepares to accept control of the situation. It can also assist the withdrawing unit with route reconnaissance, route maintenance, fire support, and CSS. Both forces closely coordinate the withdrawal. After coordination, the withdrawing unit delays to a battle handover line, conducts a passage of lines, and moves to its final destination.

b. **Unassisted.** The withdrawing unit establishes routes and develops plans for the withdrawal, then establishes a security force as the rear guard while the main body withdraws. CSS and CS elements normally withdraw first, followed by combat forces. To deceive the enemy as to the friendly movement, the brigade or TF may establish a detachment left in contact if withdrawing under enemy pressure. As the unit withdraws, the detachment left in contact disengages from the enemy and follows the main body to its final destination.

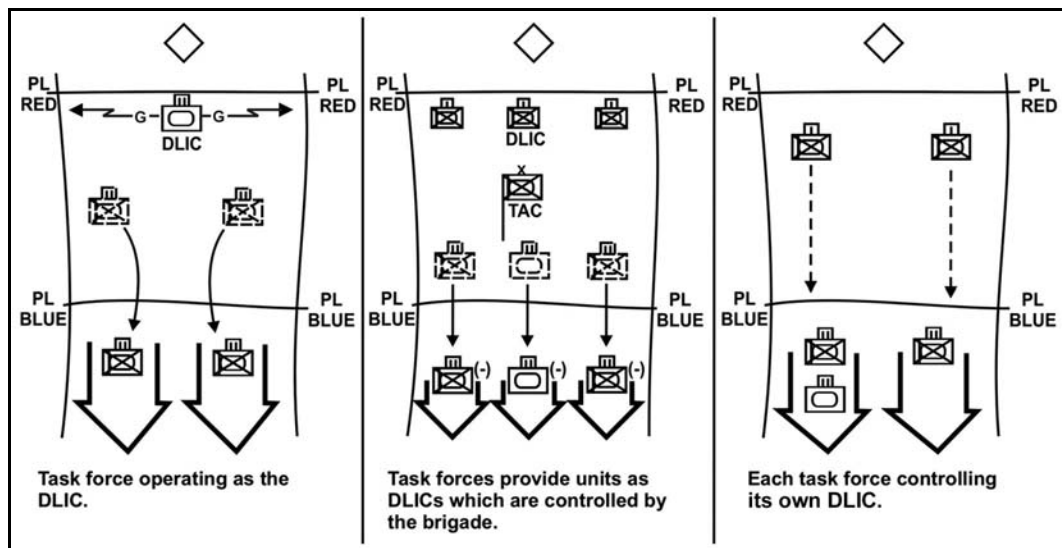
### 6-24. WITHDRAWAL ORGANIZATION

As with the delay, how the TF structures its force is a function of how the brigade organizes. The brigade normally organizes into a security force, main body, and reserve. It may elect to use a single TF or elements of a TF as the security or reserve force. It may also organize a detachment left in contact or stay-behind forces, if required by the enemy situation. If operating independently, the TF organizes itself in the same manner. FBCB2 is a major asset in withdrawals, and the TF should plan for its continuous operations before withdrawals.

a. **Security Force.** The security force maintains contact with the enemy until ordered to disengage or until another force takes over the task. It simulates the continued presence of the main body, which requires additional allocation of combat multipliers beyond that normally allocated to a force of its size. When withdrawing under enemy pressure, the security force establishes or operates as a detachment left in contact to provide a way to break contact from the enemy sequentially. When conducting the

withdrawal without enemy pressure, the security force acts as a rear guard because the most probable threat is a pursuing enemy.

b. **Detachment Left In Contact.** The detachment left in contact is an element that is left in contact as part of the previously designated (usually rear) security force while the main body conducts its withdrawal. Its purpose is to remain behind to deceive the enemy into believing the brigade or TF is still in position while the majority of the unit withdraws. The detachment left in contact should be one of the strongest of the subordinate units with the most capable leadership. It will be the unit under the greatest pressure, and the success of the withdrawal often depends on its effectiveness. The commander must establish specific instructions about what to do if the enemy attacks and when and under what circumstances to delay or withdraw. The brigade organizes a detachment left in contact in one of three ways (Figure 6-6).



**Figure 6-6. Methods for organizing the detachment left in contact.**

(1) **Single Task Force.** A single TF operates as the detachment left in contact. This is the most effective option since it provides for effective task organization and C2.

(2) **DLIC Element Formed from Each Task Force.** Each TF provides forces for the detachment-left-in-contact mission. The resulting DLIC element then operates under the brigade’s control. This is the least desirable option since it complicates C2 and task organization and requires significant changes to the communications architecture. The brigade most commonly uses this option when the subordinate TFs have lost significant portions of their command and control capabilities.

(3) **Task Force Control of Separate DLICs.** Each TF establishes and controls its individual detachment left in contact. The brigade uses this option when it is operating over a wider area or one with multiple corridors in the withdrawal AO. This method allows for effective dispersion of forces while maintaining standard C2 relationships.

c. **Company Team DLIC.** When the TF is the DLIC or has its own DLIC (subparagraphs 1 and 3 above), it normally gives the mission to a company team. Again, the company team left in contact should be the most capable of the subordinate units. The TF should establish an advance guard on its route of movement. It may designate a

company team or the scout platoon reinforced with tanks, infantry, and mortars as the advance guard. The TF should task-organize both the DLIC and the advance guard with engineers, assigning mobility assets to the advance guard and obstacle and mobility assets to the DLIC. The TF main body consists of the remaining company teams, command posts, CSS assets, remaining engineers, and the mortars if they are not task-organized to support either the DLIC or the advance guard. The TF may designate a reserve platoon from the single company team in the main body. To create flank security, it uses the scout platoon, engineers, or elements of the main body team.

#### **6-25. WITHDRAWAL PLANNING CONSIDERATIONS**

Because the force is most vulnerable if the enemy attacks, the commander and staff normally plan for a withdrawal under enemy pressure. They also develop contingency plans for a withdrawal without enemy pressure.

a. **Planning Considerations.** During planning, the commander and staff specifically consider the following:

- Disengagement criteria (time, friendly situation, enemy situation).
- Plan for a deliberate break in contact from the enemy.
- Plan for deception to conceal the withdrawal for as long as possible.
- Rapid displacement of the main body, safeguarded from enemy interference.
- Selection and protection of withdrawal routes and alternates.
- Siting of obstacles behind the DLIC to complicate pursuit.

b. **Commander's Intent.** The commander develops his vision of the battle based on withdrawing under enemy pressure. He must determine the composition and strength of the security force, main body, and reserve. The commander must clearly define how he intends to deceive the enemy as to the execution of the withdrawal, how he intends to disengage from the enemy (use of maneuver, fires, and obstacles), and the final end state of the operation in terms of time, location, and disposition of forces.

#### **6-26. WITHDRAWAL SCHEME OF MANEUVER**

A withdrawal may be assisted or unassisted and may take place with or without enemy pressure. The plan considers which of the variations the TF faces based on the higher headquarters' order and the enemy situation.

a. **Assisted Withdrawal.** In an assisted withdrawal, the staff coordinates the following with the assisting force:

- Actions of the assisting security force that the TF will pass through or around.
- Reconnaissance of withdrawal routes.
- Designation of forces to secure choke points or key terrain along the withdrawal routes.
- Designation of elements to assist in movement control, such as traffic control points.
- Designation of required combat, CS, and CSS to assist the withdrawing TF in disengaging from the enemy.

b. **Unassisted Withdrawal.** In an unassisted withdrawal, the TF establishes its own security and disengages itself from the enemy. It reconnoiters and secures routes that it uses in its rearward movement while sustaining itself during the withdrawal.

c. **Withdrawal under Enemy Pressure.** In a withdrawal under enemy pressure, all units other than the rear guard or DLIC withdraw simultaneously when available routes allow. Several factors influence the decision to withdraw simultaneously:

- Subsequent missions.
- Availability of transportation assets and routes.
- Disposition of friendly and enemy forces.
- Level and nature of enemy pressure.
- Degree of urgency associated with the withdrawal.

(1) **Transition.** The element that will be the DLIC or rear guard must transition to cover the TF's AO. Simultaneously, the TF must prepare its CSS assets and the remainder of the force to begin a rapid withdrawal to the rear. The TF should seek to move on two routes to gain speed and shorten formations. Using more than two routes exceeds the ability of the TF to maintain security. Often, only a single route will be available.

(2) **Breaking Contact.** The TF commander essentially has two options for breaking contact--break contact using deception and stealth or break contact quickly and violently under the cover of supporting fires reinforced by obstacles to delay pursuit. He bases his choice on the factors of METT-TC.

d. **Withdrawal without Enemy Pressure.** When conducting a withdrawal without enemy pressure, the commander can focus the plan on the best method to displace forces rapidly. He has the option of taking calculated risks that increase his force's displacement capabilities. He may order the main body to conduct a tactical road march instead of moving in tactical formations, or he may move on as many routes as are available with reduced security in order to gain speed.

## 6-27. WITHDRAWAL PREPARATION

The commander prepares the TF for the withdrawal through inspections and rehearsals in the same fashion as discussed with other defensive operations. Inspections for this mission focus on subordinate unit preparations to ensure a clear understanding of the scheme of maneuver and commander's intent. During an assisted withdrawal, the commander ensures adequate coordination for battle handover and passage of lines. The focus of the rehearsal for the withdrawal is actions to maintain security, disengagement from the enemy, and the movement of forces. Key leaders or liaisons from the assisting force should attend the rehearsal. The commander ensures control measures, including fire support coordination measures, fully support the withdrawal. Leaders rehearse the plan against the full range of possible enemy actions. They rehearse contingencies for reverting to a delay, committing the reserve, and reacting to enemy interdiction of movement routes.

## 6-28. WITHDRAWAL EXECUTION

Execution of the TF withdrawal essentially follows this pattern:

- Task-organizing and positioning security and deception forces.
- Reconnoitering withdrawal routes and subsequent positions.
- Preparing obstacles to support the DLIC and withdrawal.
- Preparing wounded soldiers and damaged equipment and nonessential supplies for movement.

- Moving nonessential CS and CSS units to the rear.
- Positioning MPs and other assets for traffic control.
- Initiating movement, leading with forward security forces.
- DLIC's breaking of contact and movement as a rear guard.

#### **6-29. CONCEALING THE WITHDRAWAL**

The first priority is to conceal the withdrawal from the enemy. As the brigade or TF initiates the initial movement of forces, it must take measures to deceive the enemy and to maintain OPSEC. The following actions assist in maintaining OPSEC:

- Maintenance of the defensive pattern of the whole force across the AO, simulated by the DLIC.
- Maintenance of communication and information security.
- Avoidance of establishing patterns of movement that may indicate friendly intentions.
- Establishment of security focused on destroying enemy reconnaissance forces.
- Use of multiple withdrawal routes.
- Movement during limited visibility and along covered and concealed routes.

#### **6-30. DISENGAGEMENT IN A WITHDRAWAL**

The security force remains in position and maintains a deception while the main body moves as rapidly as possible rearward to intermediate or final positions. After the main body withdraws a safe distance, the commander orders the security force to begin its rearward movement. Once the security force begins moving, it assumes the duties of a rear guard. The security element must balance security and deception with speed as it disengages. It maintains tactical movement and security techniques until it is clear that the enemy is not pursuing and contact has been broken; it then withdraws as rapidly as possible. The main body moves rapidly on multiple routes to designated positions. It may occupy a series of intermediate positions before completing the withdrawal. CS and CSS units, along with their convoy escorts, usually move first and precede combat units in the movement formation. Commanders enforce the disciplined use of routes during the withdrawal. Despite confusion and enemy pressure, subordinate units must follow specified routes and movement times.

#### **6-31. ACTIONS ON CONTACT IN A WITHDRAWAL**

Security forces counter any enemy attempts to disrupt the withdrawal or pursue the brigade or TF. If the security force and the reserve cannot prevent the enemy from closing on the main body, the commander commits some or all of the main body to prevent the enemy from interfering further with the withdrawal. The main body delays, attacks, or defends as required by the situation. In this event, the withdrawal resumes at the earliest possible time. If the enemy blocks movement to the rear, friendly forces shift to alternate routes and bypass the interdicted area. Alternatively, they may attack through the enemy.

#### **6-32. TERMINATING THE WITHDRAWAL**

Once the brigade or TF successfully disengages from the enemy, it normally has the following options:



- Rejoin the overall defense.
- Transition into a retirement.
- Continue moving away from the enemy and toward its next mission area.

The higher headquarters defines the next mission. Follow-on missions are normally planned as the withdrawal is being planned or executed.

### 6-33. RETIREMENT

A retirement is a retrograde operation in which a force that is not in contact with the enemy moves to the rear in an organized manner. The TF conducts a retirement as part of the brigade to reposition for future operations.

a. **Organization.** The brigade normally organizes into security elements and a main body. A subordinate TF may serve either as a security element or as a part of the main body. The TF normally organizes itself with security, main body, and reserve elements, depending on the situation and where the TF is in the movement scheme. The formation and number of columns employed depend on the number of available routes and the potential for enemy interference. The commander typically wants to move his major elements to the rear simultaneously.

b. **Planning Considerations.** The commander and staff develop a movement plan based on the terrain, friendly situation and commander's guidance, and enemy situation. They develop the movement formation and order of movement to balance the need for security and speed. Security forces protect the main body from surprise, harassment, or attack by any pursuing enemy forces. Normally, each march column maintains an advance guard, rear guard, and flank security, depending on the situation with adjacent friendly forces and the likelihood of enemy interference. The main body may organize into an approach march or tactical road march if speed is most important and the need for security is low.

c. **Preparation.** During preparations, brigade and TF units conduct rehearsals and prepare for movement. Units maintain OPSEC and security operations and dispatch advance parties and quartering parties as required.

d. **Execution.** During a retirement, the brigade and its TFs normally move to assembly areas to prepare for future operations. TFs move in accordance with established movement times and routes. Strict adherence to the movement plan is essential to avoid congestion. The staff closely supervises the execution of the movement plan. CSS and CS units usually move to the rear first.

## Section III. DEFENSIVE PLANNING CONSIDERATIONS

This section contains planning considerations applicable for defensive operations.

### 6-34. DEFENSIVE PLANNING

Planning a defensive operation is a complex effort requiring detailed planning and extensive coordination. In the defense, synchronizing the effects of the TF combat and supporting systems allows a commander to apply overwhelming combat power against selected advancing enemy forces to unhinge the enemy commander's plan and destroy his combined arms team. All defensive operations are a mix of static and dynamic actions. As an operation evolves, the commander knows he will probably need to shift his decisive and shaping operations to press the fight and keep the enemy off balance.

a. **Commander's Vision.** The first step is the expression of the commander's visualization of anticipated enemy actions integrated with the staff's IPB. The TF IPB and the brigade IPB should not differ significantly, giving the TF commander and staff a clear understanding of how the brigade commander envisions the enemy will fight and his plan for the operation. From that, the TF commander and staff refine the IPB to focus on the details of the operation in the TF AO. The brigade commander normally defines where and how the brigade will defeat or destroy the enemy. The TF commander defines how he envisions the TF will execute its portion of the brigade fight.

b. **How and Where to Defeat the Enemy.** The commander and staff base their determination of how and where to defeat the enemy on where they believe the enemy will go, the terrain, and the forces available. The brigade commander may define a defeat mechanism that includes the use of single or multiple counterattacks to achieve success. The TF commander and staff analyze their unit's role in the brigade fight and determine how to achieve success. In an area defense, the TF usually achieves success by massing the cumulative effects of obstacles and fires to defeat the enemy forward of a designated area, often in conjunction with a brigade counterattack. In a delay operation, the TF achieves success by combining maneuver, fires, obstacles, and avoidance of decisive engagement until conditions are right to achieve the desired effect of gaining time or shaping the battlefield for a higher echelon counterattack.

c. **Forces and Assets Available.** The commander and staff analyze the forces and assets available, with particular attention to the obstacle assets and fire support allocated by the brigade. The staff must define the engineer and fire support allocation in terms of capability. For example, they should define engineer capability in terms of the number of obstacles of a specific effect engineers can emplace in the time available. Fire support analysis should include the number of targets to be engaged, at what point in the battle they should be engaged, and with what expected result.

d. **Effects.** With a definitive understanding of the assets available, the commander and staff determine what effects forces, fires, and obstacles must achieve on enemy formations (by avenue of approach) and how these effects will support the brigade's and TF's defeat mechanism. They define the task(s) and purpose for subordinate units and establish priorities for CS and CSS. They develop obstacle and fire support plans concurrently with the defensive force array, again defining a task and purpose for each obstacle and target in keeping with the commander's stated EFSTs and intended obstacle effects. The desired end state is a plan that defines how the commander intends to mass the effects of direct and indirect fires with obstacles and use of terrain to shape the battlefield and defeat or destroy the enemy.

### **6-35. INTELLIGENCE PREPARATION OF THE BATTLEFIELD**

As with all tactical planning, IPB is a critical part of defensive planning. It helps the commander to define where to concentrate combat power, where to accept risk, and where to plan potential decisive actions. To aid in the development of a flexible defensive plan, the IPB must present all feasible enemy courses of action. The essential areas of focus are--

- Analyze terrain.
- Determine enemy force size and likely COAs with associated decision points.
- Determine enemy vulnerabilities.

a. **Analyze Terrain.** The staff determines ground and air mobility corridors and avenues of approach to determine where the enemy can maneuver to reach his likely objectives and to identify limitations on friendly maneuver and positioning. Identification of terrain that creates potential enemy vulnerabilities and opportunities for friendly attack, such as choke points, is critical. The brigade engineer can assist the TF staff's terrain analysis by providing terrain analysis products utilizing the DTSS, which can help in identifying critical terrain as well as in positioning weapons systems and intelligence assets. Once they receive their area of operation for reconnaissance or preparation, subordinate units can conduct their own terrain analysis using physical reconnaissance and the line-of-sight analysis function in FBCB2. The terrain analysis must achieve a level of fidelity that allows for effective positioning of direct fire weapons systems and observers. It must identify intervisibility lines, fields of fire, and dead spaces and integrate the effects of weather. The brigade staff can assist the TF staff by supplying weather impact on trafficability, visibility, and systems operations through data generated by the integrated meteorological system (IMETS) at division. The result of the terrain analysis should be a modified combined obstacle overlay (MCOO) and identification of defensible areas. The staff should transmit results of the analysis digitally to subordinate units. When it has analyzed the TF's assigned AO, the staff should expand its analysis to adjacent AOs and areas forward and to the rear of the assigned AOs, in which the TF may operate as the brigade operation progresses.

b. **Determine Enemy Force Size, Likely COAs, and Decision Points.** The staff determines the size enemy force that each avenue of approach and mobility corridor can support. The expected size of the enemy force drives determination of friendly force allocation, fires, and obstacle effort. It also assists the commander and staff in understanding how the enemy will utilize his forces and the terrain. The enemy COAs developed must be feasible and reflect the enemy's flexibility and true potential. All COAs should define the following:

- Likely enemy objectives.
- Enemy composition, disposition, and strength.
- Schemes of maneuver, to include routes, formations, locations and times the enemy may change formations, possible maneuver options available to the enemy, and key decision points.
- Time and distance factors for the enemy's maneuver through the area of operation.
- Likely employment of all enemy combat multipliers including artillery, air defense, obstacles, chemical strikes, dynamic obstacles, and attack aircraft.
- Likely use of all enemy reconnaissance assets and organizations, to include likely reconnaissance objectives, reconnaissance avenues of approach, times to expect enemy reconnaissance, and likely locations of enemy observers and observation posts.
- Identification and likely locations of enemy high-value targets such as artillery formations, reserves, and C2 nodes.
- Likely locations, compositions, strengths, employment options, and time and distance factors for enemy reserves and follow-on forces.

- Locations of enemy decision points that determine selection of a specific course of action.
- Likely breach sites and points of penetration.

The staff should graphically portray the results of this IPB step on a situation template with a COA statement and appropriate notes. The S2 and staff use this to develop the initial intelligence, reconnaissance, and surveillance OPORD that initiates reconnaissance and security operations. As planning progresses, they must update the ISR OPORD, to include fire support operations (see Chapter 4, ISR Operations). The staff should distribute all products digitally to the entire staff and subordinate units to support parallel planning.

c. **Determine Enemy Vulnerabilities.** The staff identifies potential enemy vulnerabilities based on the enemy's tactics, friendly and enemy capabilities, the terrain, and the weather. Seeking to engage the enemy where the terrain puts him at a disadvantage, the staff identifies--

- Restricted terrain that may slow the enemy's attack, cause a separation of forces, create difficulties in command and control, or force the enemy to conduct defile drills (for example, narrow valleys, passes, or urban areas).
- Choke points or natural obstacles that may cause a loss of momentum, a potential fragmenting of forces, or a vulnerable concentration of forces (for example, rivers and canals).
- Terrain that canalizes enemy formations into areas that provide defending forces good fields of fire, observation, and flanking fires.
- Areas dominated by key or defensible terrain that allows massing of fires.

To be successful at providing IPB products to support the commander and subordinate units, the entire staff must participate as a whole. They must be knowledgeable in friendly and enemy capabilities and terrain analysis and able to execute the process rapidly. The results must be detailed, legible, and disseminated quickly to support planning at all echelons.

### **6-36. RESERVE**

The reserve is a force withheld from action to be committed at a decisive moment. It provides the commander with the flexibility to exploit success or deal with a tactical setback and the flexibility to respond in situations where there is a great deal of uncertainty about the enemy. Normally, the TF commander can only allocate a platoon as a reserve. This decreases the ability of the TF to respond to tactical emergencies or to exploit success. It increases the significance of the brigade's reserve element, which may be a company team or a two-company TF operating over an extended area. On the modern battlefield, situational obstacles, fires, CAS, and attack aviation will increasingly be used to augment reserve forces, usually at the brigade level.

a. The choice of a force designated to be a reserve depends upon the factors of METT-TC. Generally, a tank platoon is ideal because of its mobility, firepower, and limited obstacle breaching capability. In close terrain against an enemy with dismounted infantry, an infantry force may be best suited. In compartmented or restricted terrain against a mechanized enemy, mobile Javelin teams can be an effective reserve force.

b. The reserve's likely tasks are issued as planning priorities and may include one or more of the following:

- Counterattack locally.
- Defeat enemy air assaults
- Block enemy penetrations.
- Reinforce a committed team.
- Protect rear area operations.
- Secure high-value assets.

c. During defensive preparations, the TF commander may employ his reserve in other tasks, such as security operations or to assist security of TF logistics sites. The commander must balance these uses with the need to protect his reserve and with the reserve commander's requirement to conduct troop-leading procedures, coordination, and reconnaissance.

d. The commander and staff must determine where and under what conditions the reserve force is likely to be employed in order to position it effectively and give it appropriate planning priorities. The reserve force commander must analyze his assigned planning priorities, conduct the coordination with units that will be affected by his maneuver and commitment, and provide information to the commander and staff on routes and employment times to designated critical points on the battlefield.

#### **Section IV. SEQUENCE OF THE DEFENSE**

The TF may assume a defensive mission following an attack of its own or in anticipation of an enemy attack. The following general sequence of operations applies to planning and executing all defensive operations: occupation and establishment of security, preparation and continued security operations, security area engagement, main battle engagement, and follow-on missions.

#### **6-37. OCCUPATION AND ESTABLISHMENT OF SECURITY**

Normally, the brigade has established some form of security before the TF moves into the area. However, the TF must still provide for its own security, especially on expanded or complex terrain. If transitioning from an offensive operation, the brigade and TFs establish the security area well beyond where the main battle area is desired in order to prevent the enemy from observing and interrupting defensive preparations and identifying unit positions. If they cannot push the security area forward to achieve this, the brigade and its TFs may have to hold their positions initially as they transition and then withdraw units to the defensive main battle area, establishing a security force in the process.

a. **Movement into Unsecured AO.** If the TF is moving into an unsecured AO, it may lead with the scout platoon, possibly reinforced with tanks or infantry elements and mortars. Depending on the situation, the TF may send a company team to secure the area. The mission of the security force is to clear the area, check for contaminated areas and obstacles, and establish security for the TF main body. After clearing the TF's logistics sites and the area where the company teams will be positioned, the security force should position itself to--

- Prevent enemy observation of defensive positions.
- Defeat infiltrating reconnaissance forces.
- Prevent the enemy from delivering direct fires into the TF defenses.
- Provide early warning of the enemy's approach.

b. **Positioning of Forces.** The positioning of the TF security elements must be integrated into the security operations of the brigade and adjacent TFs. In contiguous or linear defenses, the brigade commander normally organizes and defines the security area forward of the FEBA, assigning the TFs AOs of the battlefield to prevent gaps in the brigade security. The key is to integrate operations at the brigade level and again at the TF level, using all available resources to execute security operations.

c. **Leaders' Reconnaissance.** When feasible, the commander and subordinate leaders conduct a reconnaissance of the AO to develop most of the plan based on their view of the actual terrain. The commander and staff develop a plan for the leaders' reconnaissance that includes provisions for security, leaders and key staff members required to participate, designation of a recorder, areas to be reconnoitered, and time allocated for the reconnaissance. When available, the commander may use aviation assets to conduct the leaders' reconnaissance.

### 6-38. PREPARATION AND CONTINUED SECURITY OPERATIONS

Preparation of the defense includes planning and plan refinement, positioning of forces, constructing obstacles, planning and synchronizing fires, positioning logistics, and conducting inspections and rehearsals. Throughout the preparation phase, security operations must continue without interruption. Security forces may be assigned any combination of screen, guard, and area security missions. The scout platoon may be positioned to screen and provide early warning along most likely enemy avenues of approach, reinforced in depth with sections or platoons from the company teams.

a. **Security.** Security is a consideration throughout the area of operations. The TF must array security forces in depth to provide protection and to reduce the potential for enemy infiltration. It must also secure the main battle area to prevent enemy reconnaissance, reduction of obstacles, targeting of friendly positions, and other disruptive actions. Company teams must secure obstacles, battle positions, and hide positions. Elements in the TF must provide their own security, augmented by vehicles that are being repaired. With extended lines of communication, the TF may also secure logistical elements moving forward from the BSA to support the TF.

b. **Dispersion.** Forces should be widely dispersed and hidden to reduce vulnerability and aid in OPSEC.

c. **Integration.** Integrate reconnaissance and ground maneuver units into the security forces. Utilize reconnaissance forces primarily to locate enemy elements and attack them with indirect fires but not to engage in direct fire attack except in self-defense. Clearly establish the C2 headquarters and communication architecture for the security force. (This can be one of the most challenging missions in terms of tactical internet management.)

### 6-39. SECURITY AREA ENGAGEMENT

The TF normally does not have a significant security area engagement as this is largely the domain of brigade for shaping the battlefield and setting favorable conditions for the close fight. The TF may execute some engagement tasks in the security area to support its own or higher's defensive scheme. These tasks may include--

a. **Execution of Planned Indirect Fires.** The TF's planned indirect fires usually consist of security force elements' or a fire support team's (FIST's) execution of one or

two indirect fire targets on a primary enemy avenue of approach. This may be in support of the higher headquarters' scheme of fires since the brigade usually controls artillery assets throughout most of the engagement.

b. **Execution of Situational Obstacles.** The TF may be tasked by higher or have integrated into its own defensive scheme the use of rapidly emplaced situational obstacles to execute in the security area. These obstacles serve to force premature enemy deployment, slowing the enemy to allow for more effective engagement with indirect fires while forcing premature expenditure of enemy engineer assets. These obstacles are usually planned and triggered relative to specific enemy attack options and are related to accomplishing a specific EFST. Maneuver forces may be employed forward to cover them with direct fires and then withdraw to positions in the main battle area.

c. **Execution of Delay Operations through the Security Area and into the MBA.** The TF may support its own or higher's scheme of maneuver by fighting a delay through the depth of the security area and into the main battle area. The purpose may be to take advantage of restricted avenues of approach, to set the conditions for a counterattack, or to avoid a decisive engagement until favorable conditions have been set.

d. **Battle Handover.** The TF may assume control of the FEBA fight from the security force as it withdraws. Transferring responsibility from the security force to the TF on the FEBA requires firm, clear arrangements for assuming command of the action, for coordinating direct and indirect fires, for the security force's rearward passage of lines, for closing lanes in obstacles, and for detailed movement planning that clears the security force out of the TF AO with minimal interference with the defense.

e. **Transition.** As security area engagements transition into the main battle area, security area forces withdraw to initial MBA or reserve positions. Some elements may maneuver to the flanks to maintain surveillance on enemy avenues of approach, providing early warning and execution of fires against following enemy forces.

#### **6-40. MAIN BATTLE AREA ENGAGEMENT**

The TF seeks to defeat the enemy's attack forward of or within the MBA. If the TF can bring sufficient firepower to shape the enemy in the security area fight, an MBA engagement may not occur. If so, then the brigade can rapidly transition and move its TFs into a strong counterattack. However, the brigade and the TFs normally defend over a large area, and enemy strength often forces a main battle area engagement. The TF commander integrates an MBA engagement that is a combined arms fight integrating both direct and indirect fires, reinforced with obstacles and organic mortars. The brigade continues to focus artillery, CAS, and attack aviation in an effort to attack the enemy continuously throughout the depth of the battlefield, so fire support to the TFs may be limited to critical points and times in the MBA fight. Combining all available fires with maneuver, obstacles, and reserve elements, the TF commander seeks to destroy the enemy or force his transition to a retrograde or hasty defense. The brigade normally specifies control measures to coordinate and focus the defensive operation.

#### **6-41. FOLLOW-ON MISSIONS**

Following a successful defense, there may be a period of confusion that the defender can exploit. Given the information capabilities of the TF and brigade, counterattacks can be executed quickly based on branches and sequels to the plan, before the enemy can secure

his gains or organize a defense. METT-TC, ISR results, and the higher commander's concept of operations dictate the TF's follow-on mission. If the situation prevents offensive action, the TF continues to defend. As in the initial establishment of the defense, gaining security area space is critical. A local counterattack can provide space for a security area and time to reorganize. Any attack option must pay particular attention not only to the terrain and enemy, but also to friendly obstacles (and their destruction times if applicable) and areas where dual-purpose improved conventional munitions (DPICM) or bomblets have been used. If the TF or brigade cannot counterattack to gain adequate security space, then the brigade may have to direct one TF to maintain contact with the enemy and guard the AO while others move to reestablish the defense farther to the rear. Whether continuing to defend or transitioning to offensive operations, the TF must quickly reorganize. Key reorganization tasks include--

- Establishing and maintaining security.
- Reestablishing C2 and communications architecture.
- Reorganizing platoons and teams.
- Treating and evacuating casualties.
- Conducting emergency resupply.
- Recovering damaged equipment and initiating repair operations.
- Processing EPWs.
- Refining and updating the SU.

### **Section V. DEFENSIVE TECHNIQUES**

The battalion task force normally defends using one of five basic techniques of defense: defend an AO, defend a battle position, defend a reverse slope, defend a strongpoint, and defend a perimeter. The brigade normally assigns the TF an AO to defend.

#### **6-42. DEFENSE OF AN AREA OF OPERATIONS**

A defense in AO provides the greatest degree of freedom of maneuver and fire planning within a specific area. The brigade most often uses this method of control when it has an adequate amount of depth and width to the battlefield and does not desire decisive engagement early in the MBA fight. The brigade frequently assigns defense of an AO to task forces. Less frequently, a task force commander may assign his teams AOs to defend. Phase lines, engagement areas, battle positions, and obstacle belts help coordinate forces and achieve synchronized action. During defensive preparations, the commander and key staff officers use backbriefs, inspections, and rehearsals to ensure that the defensive operation is coordinated and that unacceptable or unintended gaps do not develop. Use of AOs allows flexibility and prevents the enemy from concentrating overwhelming firepower on the bulk of the defending force. Forces defending against an enemy with superior mobility and firepower must use the depth of their positions to defeat the enemy. The depth of the defense must come from the initial positioning of units throughout the AO--not from maneuvering. A properly positioned and viable reserve enhances depth (Figure 6-7).



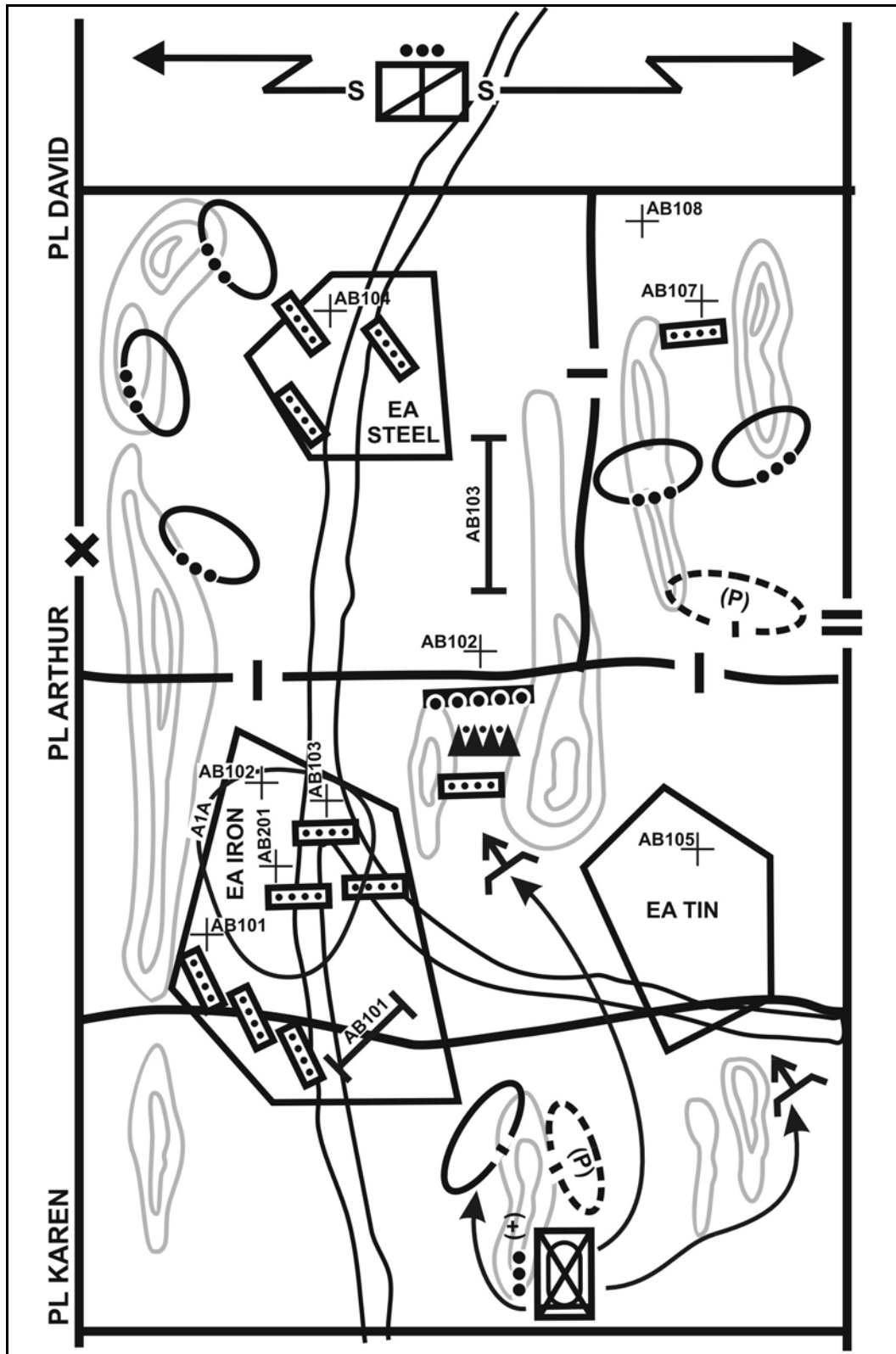


Figure 6-7. Defense of an area of operations.

a. **Positions.** A TF defending against a mounted enemy uses a series of mutually supporting antiarmor positions. These should be located on armor-restricted terrain, protected by infantry, and strengthened by obstacles.

b. **Security.** The AO defense is more effective against armor but more vulnerable to infantry attack or combined arms action, which can be directed against one position at a time. Position preparation must emphasize all-round security and mutual support.

c. **Deployment in Depth.** Forces deployed in depth must confront the enemy with effective fires from multiple locations as he tries to maneuver. The AO is organized around dispersed, small units that attack the enemy throughout the depth of his formations. The focus of this technique is the enemy force. Mines and other obstacles, infantry positions, and patrols can close gaps that fire cannot cover effectively due to terrain masking or heavily wooded areas. The commander can position dismounted infantry along mounted avenues of approach within restricted terrain, thereby maximizing its capabilities. He can position mounted forces either to engage armor and mechanized forces with antiarmor weapons or to provide rapid precision maneuver in the form of counterattacks.

d. **Engagement Options.** The commander has two engagement options when defending an AO. He chooses the appropriate one based mainly on the restrictions of the terrain and his expectation of achieving surprise. His first option is to begin engaging at maximum optimum range, based on the terrain and available weapons systems. His second option is to allow the enemy to move within direct fire range of antiarmor weapons and machine guns. The defender then engages the enemy with violent hasty and deliberate counterattacks designed to destroy the enemy from any direction. In restrictive terrain, this option denies a more mobile enemy force any firepower or mobility advantage.

(1) ***Engage Throughout the Depth/Width of the Attacker.*** The defender initiates fires at long ranges with FA, tactical aircraft, and attack helicopters to begin to break up the continuity of the attack. As the enemy closes to within range of organic heavy antiarmor weapons, these weapons further disrupt enemy synchronization and destroy key vehicles. When the enemy enters the engagement range of the TF's organic weapons, antiarmor weapons engage him from multiple unexpected directions and destroy him.

(2) ***Allowing Limited Penetration of the AO.*** This technique is offensively oriented. It allows for planned penetrations, ambushes, and counterattacks throughout the enemy formation. A forward array of forces cannot defend armor approaches. Such an array can be overrun or penetrated rapidly while under massive artillery, smoke, and direct fire suppression. To avoid penetration, the TF must array forces in depth. Concentrating the TF on narrow fronts is risky.

e. **Planning.** The commander considers the following factors when facing a mostly mechanized or armored enemy.

(1) ***Mounted Avenues of Approach.*** Avenues of approach determine enemy mounted avenues of approach and the size force that can move on each. The commander or S3 estimates the maximum number of vehicles the enemy can deploy at one time on given avenues of approach and the length of time this target array would be exposed.

(2) ***Engagement Areas.*** An engagement area is a terrain-based fire control measure situated along an enemy avenue of approach. Commanders design EAs in order to destroy a designated enemy force by massing the effects of a majority of their available

systems. The size and shape of the area is determined by the degree of maximum range intervisibility from respective weapon systems and the number of units available.

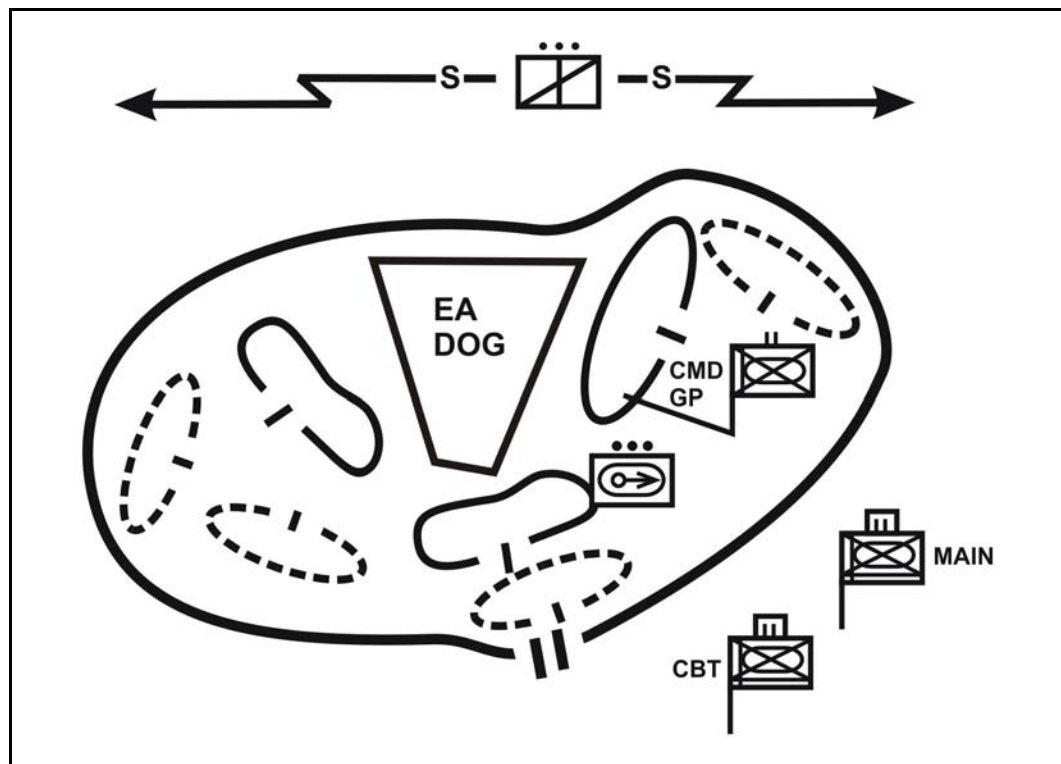
(3) **Massing of Tank, Bradley Fighting Vehicle, and Antitank Fires.** Mass antiarmor fires by assigning target engagement areas, primary and alternate sectors of fire, and TRPs. Attached antiarmor assets can be attached to or in DS of a company team.

(4) **Obstacle Planning and Integration.** Plan obstacles to disrupt, fix, turn, or block the enemy and protect positions. Encountering these obstacles increases enemy exposure time and enhances the effects of direct and indirect fires.

(5) **Integrated Fire Support.** Planned CAS sorties can provide rapid and concentrated aerial-delivered firepower in the first, crucial engagements of the battle. Mortars and artillery increase the effects of antiarmor weapons by suppressing enemy overwatch elements, forcing enemy armor to button up. Attack helicopters rapidly mass antiarmor and antipersonnel weapons and provide security on flanks and other unoccupied areas.

#### 6-43. DEFENSE FROM A BATTLE POSITION

A battle position is a general location and orientation of forces on the ground from which units defend. TF- to platoon-size units can use BPs (Figure 6-8).



**Figure 6-8. Disposition of forces in and about a battle position.**

a. **Use of Battle Positions.** Use of battle positions reduces the instructions needed to move a force. BPs are often used as graphic control measures for a FRAGO and are identified by number, letter, name, or a combination.

b. **Three Levels of Preparation for a Battle Position.** The three levels of preparation for a BP are occupy, prepare, and reconnoiter. The use of on-order BPs with

the associated tasks "prepare" or "reconnoiter" adds flexibility and depth to the defensive plan.

(1) **Occupy**. This is complete preparation of the position from which the company team will initially defend. The position is fully reconnoitered, prepared, and occupied before the "defend not later than (NLT)" time specified in the TF OPORD. The company team must rehearse the occupation, and the commander must establish a trigger for occupation of the position.

(2) **Prepare**. The unit fully reconnoiters the position and the corresponding engagement area, marking vehicle positions in the BP and fire control measures in the engagement area. From the BP, the unit must accomplish all actions to enable it to execute the mission immediately upon occupation. Planning, coordination, and rehearsals are required for the unit to displace to the BP and accomplish the mission from it. Within time constraints, the unit digs in survivability positions, constructs fighting positions, designates TRPs, develops direct and indirect fire plans, emplaces obstacles, clears fields of fire, and prestocks ammunition. Prepare missions are normally critical to the defense. A unit assigned such a mission must maintain security on the position and on the routes to it.

(3) **Reconnoiter**. The unit fully reconnoiters the engagement area and BP, planning tentative unit positions in the BP and establishing limited fire control measures in the engagement area. The unit must coordinate and plan for defense from this position. Leaders reconnoiter, select, and mark positions, routes, and locations for security elements. They coordinate movement and other actions, such as preparing obstacles and occupation plans, with other elements of the TF.

c. **Maneuver**. The commander can maneuver his elements freely within the assigned BP. To comply with the commander's intent, units can maneuver outside the BP to adjust fires or to seize opportunities for offensive action. TF security, CS, and CSS assets are often positioned outside the BP with approval from the headquarters assigning the BP.

d. **Space Allocation**. The commander allocates space to subordinate elements within the BP area based on the space available and the relative danger of nuclear and chemical attack. The TF commander thinks two levels down, or in terms of platoon BPs, when he selects a BP for subordinate company teams. He must allow enough space on each BP for dispersed primary, supplementary, and alternate positions for key weapons. The TF commander can vary the degree of maneuver elements in the TF BP by allocating larger company team BPs. Battle positions can also reflect positions in depth. They may take a shape other than the standard oblong shape which suggests a linear defense within the BP. Large positions also increase dispersion in a nuclear and chemical environment. The commander can combine AOs and BPs in the TF AO to suit the tactical situation.

e. **Types of Battle Positions**. There are five types of battle positions.

(1) **Primary Positions**. Primary positions cover the enemy's most likely avenue of approach into the area. A primary position is the best position from which to accomplish the assigned mission.

(2) **Alternate Positions**. Alternate positions are those assigned for use when the primary position becomes untenable or unsuitable for carrying out the assigned task. These positions allow the defender to carry out his original task, such as covering an avenue of approach or engagement area. Alternate positions increase the defender's

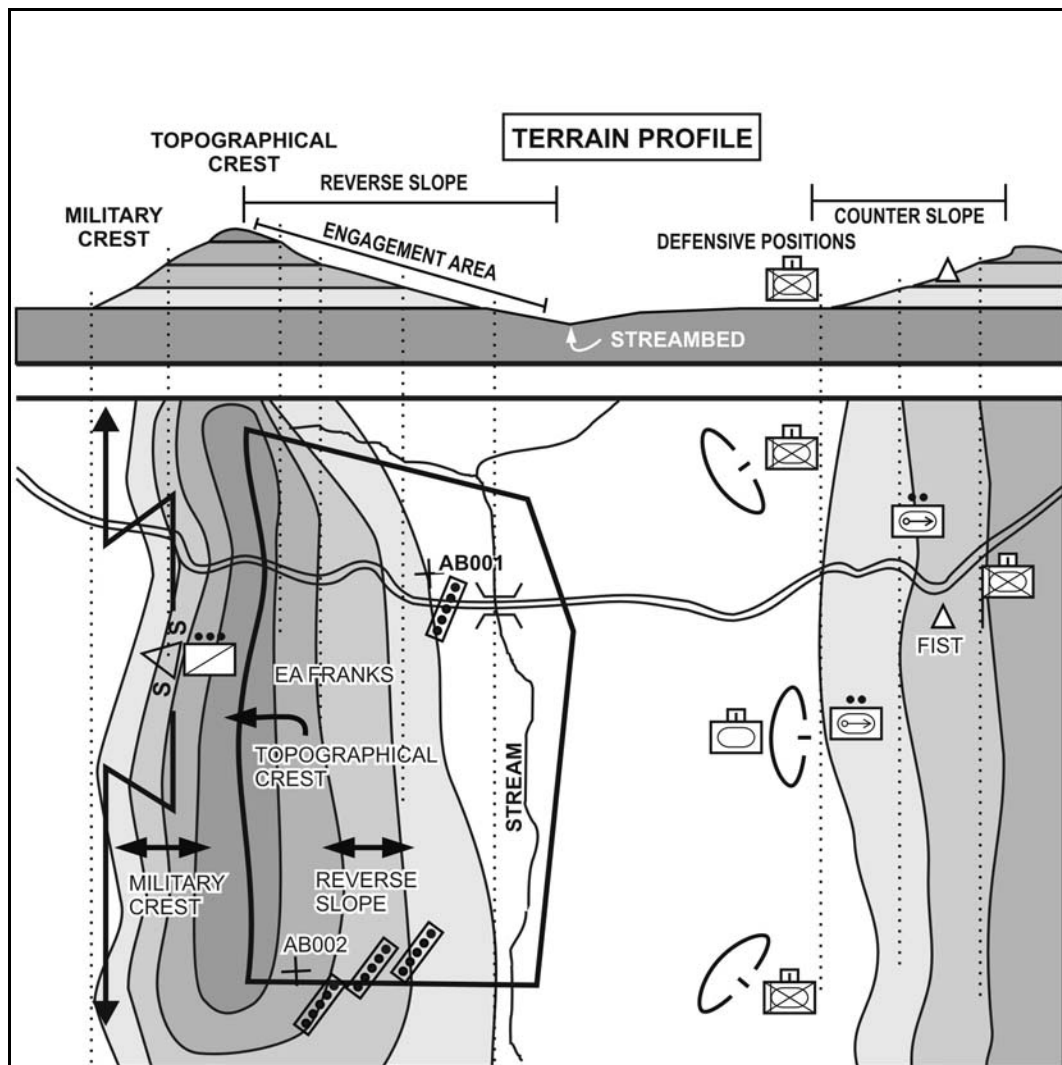
survivability by allowing engagement of the enemy from multiple positions and movement to other positions in case of suppressive or obscuring fires.

(3) **Supplementary Positions.** Supplementary positions are designated to cover avenues of approach that are not expected to be the enemy's primary avenue.

(4) **Subsequent Positions.** Subsequent positions are those to which the unit expects to move during the course of the battle. The defending unit may have a series of subsequent positions (particularly in delay operations), each with associated primary, alternate, and supplementary positions.

**6-44. REVERSE SLOPE DEFENSE**

A reverse slope defense is organized to use a topographical crest to mask the defender from the attacker's observation and from supporting direct fire (Figure 6-9).



**Figure 6-9. Organization of the reverse slope defense.**

a. **Conditions.** The TF commander may adopt a reverse slope position for elements of the TF when--

- Enemy fire makes the forward slope untenable.
  - Lack of cover and concealment on the forward slope makes it untenable.
  - The forward slope has been lost or has not yet been gained.
  - The forward slope is exposed to enemy direct fire weapons fired from beyond the effective range of the defender's weapons. Moving to the reverse slope removes the attacker's standoff advantage.
  - The terrain on the reverse slope affords better fields of fire than the forward slope.
  - The defender must avoid creating a dangerous salient or reentrant in friendly lines.
  - Surprising and deceiving the enemy as to the true location of the TF defensive positions is essential.
- b. **Advantages.** The following are some advantages of a reverse slope defense:
- Enemy ground observation of the battle area is masked, even from surveillance devices and radar.
  - Enemy direct fire weapons cannot effectively fire on the position without coming within range of the defender's weapons.
  - The enemy must try to breach obstacles on the reverse slope within direct fire range of all the defender's weapons. (The attacker cannot locate these obstacles until he encounters them, thus reducing his reaction time and maneuver space.)
  - The enemy is deceived as to the strength and location of defensive positions.
  - Enemy indirect fire is less effective since he cannot see the defender.
  - The defender gains tactical surprise.
  - The lack of enemy ground observation allows more freedom of movement within the battle area.
  - Tanks, BFVs, Javelins, and tube-launched, optically tracked, wire-guided (TOW) missile systems, if positioned properly, can mass fires on the reverse military crest; infantry small-arms weapons can contribute their close fires to the battle.
  - The unit can dig in more quickly even when the enemy is approaching because the slope of the hill covers and conceals the unit from the direct fire and observation of approaching enemy ground forces. Defenders can concentrate on position preparation.
  - The terrain protects the unit from the blast and thermal effects of enemy or friendly force nuclear weapons.
- c. **Disadvantages.** The following are some disadvantages of a reverse slope:
- Observation of the enemy may be limited, and the defender may be unable to cover obstacles to the front by direct fire.
  - The topographical crest may limit the range of important direct fire weapons. These weapons may have to locate separately from the dismounted infantry elements to exploit their range.

- The enemy holds the high ground in an attack. His attack is downhill; the counterattack is uphill. This may provide a psychological advantage to the enemy.
- Because the reverse military crest must be controlled, the effectiveness of the reverse slope defense is reduced during limited visibility.

d. **Organization of the Defensive Position.** The TF commander organizes the defensive position IAW procedures that apply to all defensive techniques.

(1) **Forward Edge of the Position.** The forward edge of the position should be within small arms range of the crest. It should be far enough from the crest that fields of fire allow the defender time to place well-aimed fire on the enemy before he reaches friendly positions.

(2) **Flanking Fires.** A reverse slope position is most effective when units on adjacent terrain can place flanking fires on the forward slope.

(3) **Security Force.** The units should establish a security force to the front to stop or delay the enemy, to disorganize his attack, and to deceive him as to the location of the defensive position. When this security element withdraws, the unit must maintain observation, indirect fire, and security to the front.

(4) **Observation Posts.** The unit establishes observation posts on or forward of the topographical crest. This allows long-range observation over the entire front and indirect fire coverage of forward obstacles. OPs are usually provided by the reserve and may vary in size from a few soldiers to a reinforced squad. They should include FOs. At night, their number should be increased to improve security.

#### 6-45. DEFENSE OF A STRONGPOINT

A strong point is a heavily fortified battle position tied to a natural or reinforcing obstacle to create an anchor for the defense or to deny the enemy decisive or key terrain (FM 3-90). The mission to create and defend a strongpoint implies retention of terrain to stop or redirect enemy formations. Strongpoint's require extensive time, engineering support, and Class IV resources to construct. An armor heavy company team could serve as the strongpoint defending team. The surveillance, target acquisition, and information-sharing capabilities of the tank enable it to destroy enemy combat vehicles rapidly and at long range. As a reserve, its capabilities enable rapid movement from hide positions to attack by fire positions. Mechanized company teams or task forces may be given strongpoint missions in rare instances, but again, the static nature of the operation and the resources required to conduct the strongpoint make it an unusual mission assignment. TF strongpoints can be established in isolation when tied to restrictive terrain on their flanks or on armor high-speed avenues of approach tied to unit defensive positions on the strongpoint flanks. A bypassed strongpoint exposes enemy flanks to attacks from friendly forces inside and outside the strongpoint.

a. **Planning a Strongpoint Defense.** The TF pays a high cost in manpower, equipment, material, and time to construct a strongpoint. It takes several days of dedicated work to construct one. Strongpoints sacrifice the inherent mobility advantage of heavy forces.

(1) **Enemy Assault.** When it cannot easily bypass a strongpoint, the unit should expect and be ready to repel repeated enemy dismounted assaults. The strongpoint will probably receive intensive artillery attacks and must be prepared with overhead cover.

Multiple positions in the strongpoint provide defense in depth. Combat vehicles committed to the strongpoint defense use multiple firing positions while infantry squads use positions tied together with trenches. A TF assigned a strongpoint mission--

- Plans movement to alternative positions in the strongpoint.
- Coordinates with forces outside the strongpoint, especially counterattack forces.
- Plans direct fires in detail and receives fire support priority.
- Establishes a small reserve to counter penetrations and, when appropriate, attack outside the strongpoint.

(2) **Mutual Support.** All positions in a strongpoint are mutually supporting (Figure 6-10). Positioning must allow massing of the fire of two or more units against an assault and prevent the enemy from isolating positions and defeating them in detail. Sectors of fire help coordinate and mass fires between positions. Avenues of approach into and around the strongpoint that cannot be covered by forces in primary positions must be kept under surveillance and covered by supplementary positions prepared in as much detail as time permits and occupied on order.

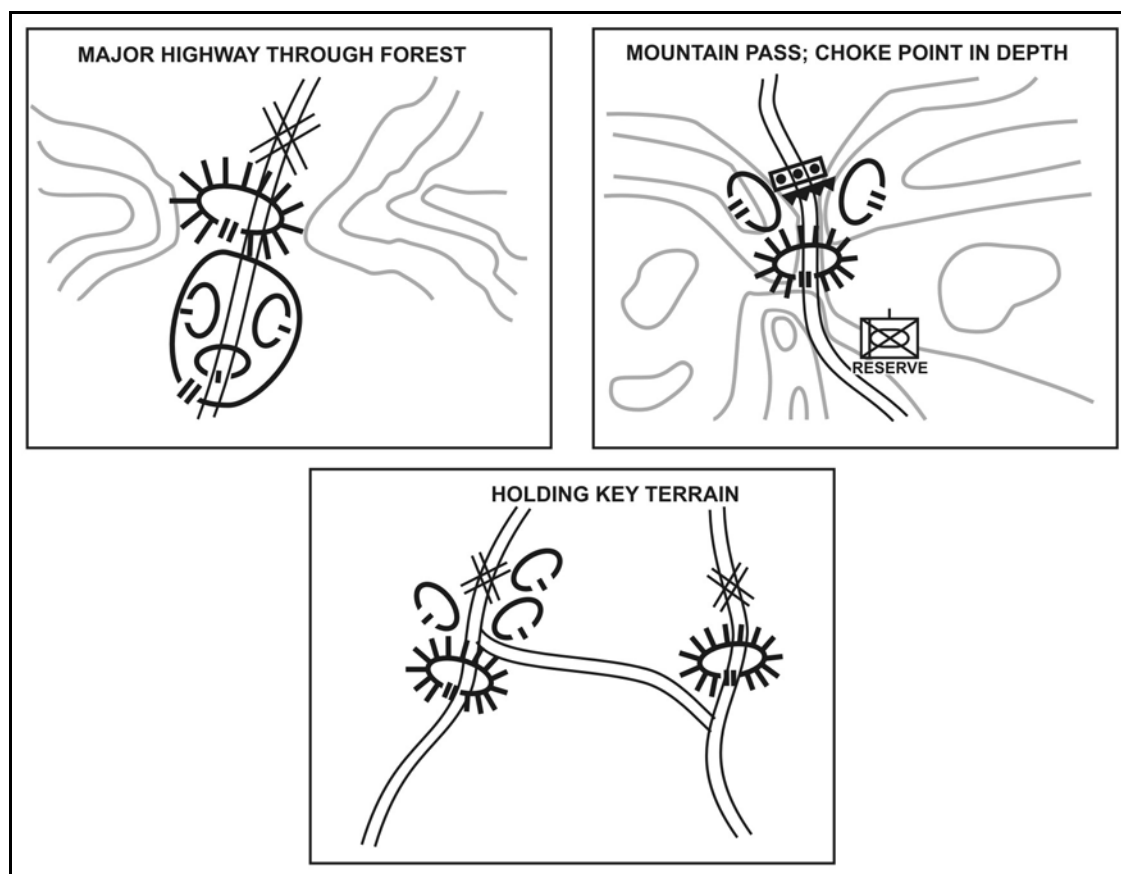


Figure 6-10. Battalion task force strongpoint.

(3) **Forces Operating outside the Strongpoint.** In some situations, the TF defends from a strongpoint with forces operating outside the strongpoint. Security forces may operate forward or perform economy of force missions. On their return to the strongpoint,



security forces either screen a secondary avenue of approach or occupy a position in depth.

(4) **Infantry Squads.** The commander may separate the BFVs and infantry squads, placing the infantry squads on restrictive terrain with the BFVs deployed in positions in depth. If available, antiarmor forces occupy positions in depth to take advantage of their long-range fires. Alternate and supplementary positions are planned throughout the strongpoint and AO. Mortars operate in split section on the reverse slope or in a built-up area in the center of the strongpoint. Combat trains, with emergency resupply of Classes II and V, are placed in prepared defilade positions or buildings in the strongpoint. Supplies are pre-positioned near primary, alternate, and supplementary positions. The brigade provides units to keep the main supply route open.

(5) **Armor Heavy Reserve.** As in the defense of a battle position, an armor heavy company team could serve as the strongpoint defending team. The surveillance, target acquisition, and information-sharing capabilities of the tank enable it to destroy enemy combat vehicles rapidly and at long range. As a reserve, its capabilities enable rapid movement from hide positions to attack by fire positions.

(6) **Security Force.** The commander may use a mechanized heavy company team as part of the security force to provide intelligence through contact and spot reports. The company team assigned the security mission screens the TF AO or along the most dangerous avenue of approach. This company team provides early warning to the TF, destroys enemy reconnaissance elements, and helps shape the battlefield so the enemy is directed against the strongpoint.

b. **Intelligence Support for a Strongpoint.** The strongpoint represents the culmination of the brigade battle staff IPB and the commander's estimate of the situation. Based on a METT-TC analysis, the brigade commander identifies the decisive terrain that, if seized by the enemy, would result in the brigade combat team's (BCT's) defeat. This decisive terrain is the strongpoint.

(1) **Terrain Analysis.** The TF S2 analyzes the terrain in a very detailed manner. Unlike other types of defense, the strongpoint must be defensible in 360 degrees. As a result, the terrain analysis must be conducted with the understanding that enemy offensive operations, from an infiltration to a major attack, could appear from any direction (multiple avenues of approach).

(2) **ISR OPORD.** The reconnaissance and surveillance plan is essential to the strongpoint's effectiveness. Some reconnaissance assets may be able to operate outside the position to provide initial early warning. If the strongpoint becomes encircled, the unit must be able to anticipate the actions of the enemy and respond internally. OPs positioned outside the position must be sustainable should the strongpoint become surrounded. The unit should have a plan for bringing patrols or other reconnaissance assets into the position despite enemy presence.

c. **Maneuver Concept.** The strongpoint defense is the most labor-intensive operation a TF commander may execute. Despite its static nature, the construction must allow for maximum flexibility. The key to an effective and sustainable strongpoint defense is to have a solid direct and indirect fire plan coupled with properly constructed fortifications. The commander must take a personal interest in the interface between combat, CS, and CSS elements.

(1) **Positions.** The selection of company team combat, CS, and CSS positions is the first priority of the TF commander. He must plan so his weapons systems can engage the enemy effectively along the major expected enemy avenue of approach. The S2's line-of-sight analysis, the IPB, and the brigade obstacle plan determine these positions. The actual construction of the TF EA and the direct fire control measures are identical to that discussed in earlier sections. The considerations for weapons systems employment, however, may be different, particularly with respect to the lack of depth in the strongpoint itself. In a strongpoint, it is much more difficult to achieve depth of fires than in AO defensive operations. Generally, infantry squads secure the outskirts alongside or slightly to the left or right front of the perimeter.

(2) **Battle Position Selection.** Once the commander has determined the locations suitable for each type of weapon system, he selects the company team BPs. He must address several considerations before finalizing the BPs. First, how much firepower is needed to cover the enemy avenue of approach? Second, how can BPs be selected so they can be responsive to enemy attacks from other directions? Third, what task organization is best suited to the terrain and meets the security needs of the TF?

(3) **Reserve.** In a strongpoint defense, it is important to maintain a reserve that can react to enemy activity against the position. The reserve may be mounted, dismounted, or both. The reserve may--

- Block an enemy penetration of the perimeter.
- Reinforce a position or section of the defense.
- Counterattack to restore a portion of the strongpoint.

d. **Strongpoint Fire Support.** Dominating terrain features, mounted and dismounted avenues of approach, and likely enemy avenues of approach hidden from direct observation should be targeted. In this way, the fire support plan will help keep the enemy at a distance from the strongpoint (Figure 6-11).

(1) If the enemy is able to reach the strongpoint in significant strength, the close-in fire support plan is essential to the integrity and survivability of the position. Fires must be planned on obstacles close to the position, even if they are danger close. Evacuation of the position may become necessary during the battle. If fires are planned on the position, the unit can destroy the enemy and reoccupy the positions for continued defense.

(2) If 360-degree indirect mortar support is required, the mortar tubes are dismounted from the vehicles so they can respond easily to calls for fire in any direction. If the mortar tubes remain in the tracks, firing in some directions will be difficult without moving the vehicle. The vehicles should remain in proximity to the tubes, dug in, and serving as an ammunition storage facility. Figure 6-11 illustrates the overall TF fire support plan.

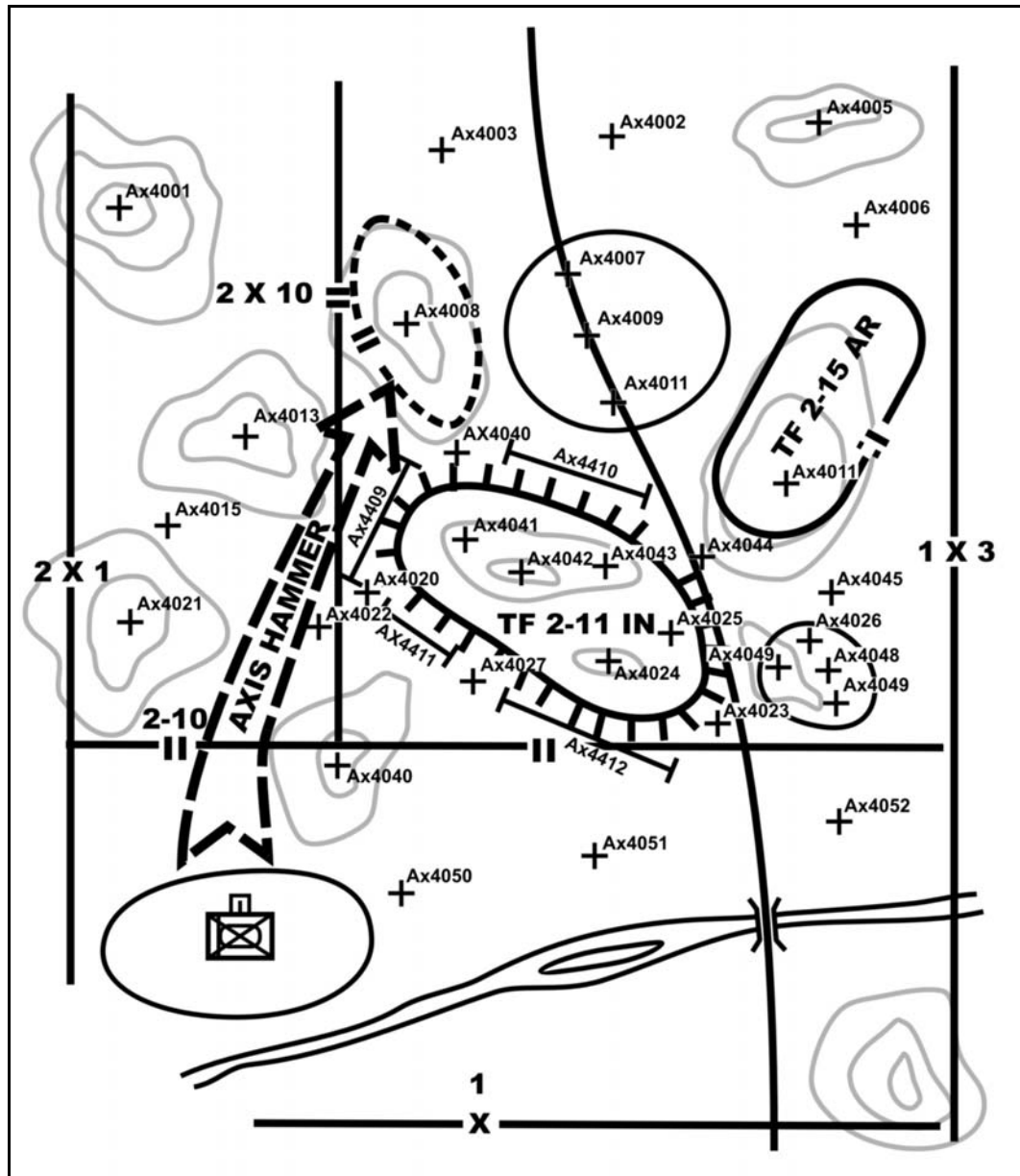


Figure 6-11. Strongpoint fire support plan.

e. **Strongpoint Engineer Support.** The engineer company commander accompanies the maneuver commander on the reconnaissance of the strongpoint area. He plans indirect fires and scatterable mines to slow, disrupt, and canalize the advancing enemy and prepares the position to make it physically impassable to tanks and to enhance the killing power of antitank (AT) weapons with obstacles. Based on the commander's guidance and priority, the engineer commander determines emplacement priority for fighting positions and obstacles and allocates the assets needed to accomplish the mission. Strongpoints are constructed from inside to outside. Regardless of the configuration of the strongpoint, the following are essential tasks to perform:

- Prepare obstacles to prevent their being overrun by tanks.
- Prepare hull down positions for fighting vehicles.

- Emplace obstacles at optimum weapons range.
- Construct protected routes between positions.
- Plan and coordinate for scatterable mines.

f. **Air Defense Artillery Support for a Strongpoint.** The air defense commander identifies positions to facilitate engagements of enemy fixed- and rotary-wing aircraft. The air defense commander ensures the engineers site actual positions properly. Engineers know how to construct positions, but the "occupant" must ensure the position is properly oriented.

g. **Strongpoint Combat Service Support.** The TF S4 helps plan for the following aspects of CSS in a strongpoint.

(1) **Cache.** The S4 examines the engineer's strongpoint construction plan and determines the best places to cache ammunition and supplies. The units refine the cache plan by positioning smaller caches adjacent to individual crew-served weapons. Once the unit caches have been identified or sited, the TF S4 develops a resupply plan. TF caches must be dispersed throughout the strongpoint to prevent a single detonation.

(2) **Medical Support.** The HSS plan must take into consideration whether to use a consolidated BAS or whether to push medical support forward. The time and distance factors to the perimeter should be considered when placing treatment facilities. A four-man litter team on average terrain can travel 900 meters and return in one hour. A six-man litter team in mountainous terrain can travel approximately 350 meters and return in one hour. The BAS should be dug in, with easy access to each supported unit, water supply, and generator. If possible, a bunker will be made available to the BAS. In an elongated strongpoint, the BAS may split its treatment teams to provide support from two locations.

(3) **Refuel Points.** Even though vehicles in the position are static, they still burn fuel during idling, particularly while running their thermal sights. The TF must develop a refueling plan.

(4) **Combat Trains CP.** The combat trains CP is dug in separately from the battalion task force CP. It serves as the alternate CP should the main CP be destroyed. It is positioned away from the main CP but in proximity to the aid station and supply activities. The CTCF must establish redundant communications with the main CP so that direct communication via landline, for example, is possible between the two headquarters.

h. **Strongpoint Command and Control.** The commander develops his strongpoint defense plan by using the terrain to its utmost advantage. The commander must be able to traverse the strongpoint and respond to an attack from any direction. His observation posts must afford the opportunity to observe the battle. Communication wire must be buried deep in the strongpoint and field phones made available throughout the position.

## 6-46. PERIMETER DEFENSE

A perimeter defense is a defense oriented in all directions (Figure 6-12). The TF uses it for self-protection. The TF establishes a perimeter defense when it must hold critical terrain in areas where the defense is not tied in with adjacent units. The TF may also form a perimeter when it has been bypassed and isolated by the enemy and must defend in place. These differences are in contrast to the strongpoint defense, in which the position

is tied in with the rest of the defense and considerable time and resources are spent to hold the ground.

a. **Planning Considerations.** While in a perimeter defense, the task force should consider--

- Placing security as far out as possible.
- Positioning armor and antiarmor weapons in protected positions and concentrating their fires on armor avenues of approach.
- Maintaining an armor pure or armor heavy reserve.

b. **Retention of Key Terrain.** The TF retains terrain key to future operations such as linkup, extraction, or breakout. The TF commander employs a security force outside the perimeter for early warning. He augments the security force with mounted or dismounted patrols and OPs controlled by subordinate company teams on the perimeter. Periodic patrols cover areas that stationary elements cannot observe.

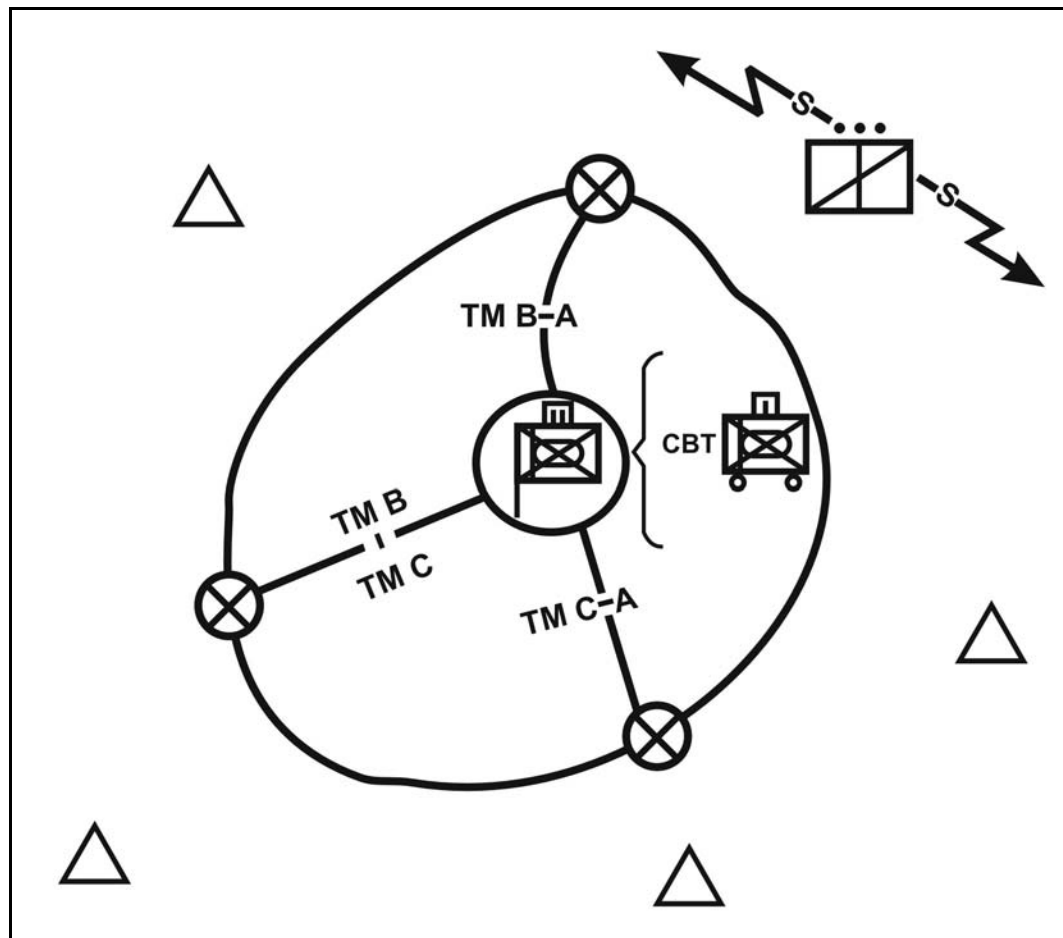


Figure 6-12. Perimeter defense.

c. **TF Reserve.** The TF reserve defends a portion of the second line of defense behind the perimeter elements. The reserve must have the mobility to react to enemy action in any portion of the perimeter. It is positioned to block the most dangerous avenue of approach and is assigned on-order positions on other critical avenues. If the enemy penetrates the perimeter, the reserve blocks the enemy penetration or counterattacks to

restore the perimeter. After committing the reserve, the commander immediately designates a new reserve force to meet other threats.

d. **C2.** If the TF forms the perimeter because of isolation, then combat, CS, and CSS elements from other units come under the tactical command of the senior combat commander in the perimeter. The commander assigns them missions based on support capabilities.

e. **CSS Support.** CSS elements may support from inside the perimeter or from another location depending on the mission and status of the TF, the type of transport available, the weather, and the terrain. All service support assets inside the perimeter should be in a protected location from which they can provide continuous support. Since resupply may have to be done by air, the position should include or be near a landing or drop zone. Resupply is often by air. The availability of LZs and drop zones (DZs) protected from the enemy's observation and fire is a main consideration in selecting and organizing the position. Since aerial resupply is vulnerable to weather and enemy fires, commanders must emphasize supply economy and protection of available stocks.

#### **6-47. COUNTERATTACK**

The task force may conduct local counterattacks to restore or preserve defensive integrity. Unless defensive operations have left the task force largely intact or with sufficient combat power, the task force usually lacks the ability to conduct a significant counterattack by itself.

a. Counterattacks are conducted to take advantage of an attacking enemy's weakened condition by striking against his flanks or rear or to deny the enemy commander the momentum and initiative. Within the context of the defending task force, it may execute a counterattack to support the brigade's defensive posture as part of a larger force seeking to complete the destruction of the enemy's attack or as part of a transition to offensive operations. Counterattacks are also conducted to dislodge an enemy from within the perimeter of a battalion defensive position. As the enemy's advance is slowed and weakened, his maneuver options become less available. As a result, he may transition to a hasty defense along the FLOT, or he may attempt to gain a foothold within a battalion's defensive position from which he can defend. This situation allows the commander to seek decisive opportunities to counterattack the enemy with all available force and ultimately secure the initiative of the battle.

b. Timing is critical to a counterattack. If committed too soon, reserves may not have the desired effect or may not be available for a more dangerous contingency. If committed too late, they may be ineffective. Once committed, counterattack forces may penetrate the enemy's flanks and attack the enemy's artillery and logistic areas or penetrate the enemy's flanks and attack them from the rear. Both actions are decisive and will create grave concern for the enemy. Adequate warning time must be given to the reserve. The reserve cannot remain ready to go indefinitely. A rested reserve force will perform better than one that has been on one hour alert for the previous 48 hours. Reserve commanders and staffs must closely monitor the flow of the battle.

c. The TF may decide to use the reserve as a counterattack force to penetrate enemy forces or defeat the attacker. Basic guidelines for counterattacks include--

- Attack one objective at a time and weight it with all available combat power and fires. Avoid piecemeal commitment of the counterattacking force. Once committed, the counterattack force is normally the main effort.
- Determine movement times based on routes available and develop clear DPs for when and where to launch the counterattack.
- Defeat the targeted enemy force before being attacked by subsequent enemy forces. Indirect fires and situational obstacles may delay follow-on attacking enemy forces.
- Determine and recognize enemy deception efforts aimed at causing the premature or indecisive commitment of the reserve.
- Seek to avoid the enemy's strength. The most effective attacks are against exposed enemy flanks and or rear. Attacks from an unexpected direction at the point and time of the enemy's greatest vulnerability have the best potential for success. Take advantage of the protection and concealment offered by the terrain and or limited visibility.
- Maintain flexibility. Although counterattack plans are developed during the planning process, the counterattack force must be prepared to quickly attack at different times and locations based on the actual situation. Anticipation of events, a clear understanding of the commander's intent, and a heavy reliance on SOPs greatly increase the agility of the counterattack force.
- When feasible, launch counterattacks around other committed units rather than through them. This reduces the vulnerability and time-consuming coordination associated with a passage of lines.
- Consider the strength, disposition, and location of the enemy's reserve. If the reserve is committed before the enemy reserve is committed, the TF may lack the ability to counter the enemy reserve. If the enemy's reserve is uncommitted, the TF must take measures to prevent its decisive commitment into the battle. Fires, situational obstacles, and CAS may be able to delay, neutralize, or destroy the enemy reserve, providing time for the TF to counterattack and recover its reserve.

d. The commander uses DPs and NAIs (developed during construction of the DST) in conjunction with ISR and battlefield results ascertained via reports and the COP to trigger execution of a counterattack. The commander and staff consider the enemy situation and estimate time and space factors relating to the movement of enemy forces. The staff considers time and space requirements for the counterattack force to close on the enemy force, attack, and then withdraw or consolidate before follow-on enemy echelons can interfere. The staff considers the likely strength and composition of the targeted enemy force to determine supporting efforts, fires, and obstacles required for supporting the counterattack objective. It considers what likely interdiction against enemy reserves and follow-on forces is necessary. The staff must determine what the reserve will do once it has completed the counterattack. If the mission of the counterattack force is to stay and defend against another enemy echelon (such as when MBA forces are weak and the reserve is still strong), it must have time to gain good defensible positions before follow-on enemy echelons can interfere. If the reserve is to withdraw after its mission and continue to serve as the TF reserve, the plan must address its reconstitution. The counterattack plan must address--

- Task(s) and purpose of the counterattack force.
- Task(s) and purpose of the counterattack force once the counterattack is completed.
- Commander's intent.
- Planning assumptions to include the size and shape of the assumed penetration or salient; the strength, composition, and disposition of the enemy force; and the status of forces in the MBA.
- Supporting efforts, units, fires, and obstacles that will support the counterattack.
- Adequate control measures such as routes, axis of advance, boundaries, RFL, objective(s), EAs, and LOA.
- Adequate FSCMs and A2C2 measures.
- Specific control measures and procedures for a passage of lines.
- Traffic control plans for ensuring movement routes remain open.

e. Effective counterattacks require detailed coordination and refinement to include reconnaissance of routes and positions, rehearsals, verification of time and space factors, fire planning, and coordination with adjacent units. Counterattack plans are rehearsed during the day and night. The counterattack force should mark routes, establish guides, and improve routes to ensure smooth execution. The reserve commander coordinates with adjacent task forces for--

- Movement and attack routes.
- Passage of lines, if required.
- Location and orientation of friendly positions and units.
- Actions for continuation of the attack to or beyond the FEBA.
- Coordination of key control measures to include boundaries, objectives, checkpoints, and the LOA. This also includes coordination of fires (target reference points, EAs, and RFL).
- Location of FOs, scouts, and reconnaissance assets communication and digital nodes.
- Location of obstacles and obstacle lanes guides and far and near lane markings.

f. The commander may commit the reserve to contain enemy penetrations when the enemy's strength prevents the TF from launching a decisive counterattack. During planning, the staff can prepare for penetrations by analyzing enemy COAs and friendly weaknesses to anticipate possible locations of penetration. During planning, the staff war-games possible enemy penetrations. It considers the actions and routes of the assumed penetrating enemy force to identify favorable terrain for countering it. The staff develops these areas as BPs, EAs, or objectives, then assigns the reserve the appropriate planning priorities to respond to the possible penetration. The staff defines routes, control measures, and FSCMs needed to control the attack. Hypothetical enemy penetrations must be considered, graphically displayed and given to all TF company commanders. Company commanders use this information in their planning. Although plans are developed in advance, the TF must be prepared to counter unexpected enemy penetrations wherever they occur.



---

## Section VI. COUNTERMOBILITY, MOBILITY, AND SURVIVABILITY INTEGRATION

Much of the strength of a defense rests on the integration and construction of reinforcing obstacles, exploitation of existing obstacles, and actions to enhance the survivability of the force through construction of fighting positions and fortifications. The commander's intent focuses mobility and survivability planning through his articulation of obstacle intent (target, relative location, obstacle effect) and priorities and establishment of priorities for survivability and mobility. Guided by that intent, the TF engineer (usually the DS engineer company commander) develops a scheme of engineer operations that includes engineer task organization, priorities of effort and support, subordinate engineer unit missions, and mobility and survivability instructions for all units. Chapter 9 contains information on engineer systems and capabilities.

### 6-48. COUNTERMOBILITY

The commander and staff develop the obstacle plan concurrently with the fire support plan and defensive scheme, guided by the commander's intent. (Figure 6-13, page 6-62) illustrates an example of a TF obstacle plan.) They must integrate into the ISR order the use of intelligent minefields such as Raptor, if allocated. The commander's intent for countermobility should contain three elements.

a. **Target.** The target is the enemy force that the commander wants to affect with fires and situational obstacles. The commander identifies the target in terms of the size and type of enemy force, the echelon, the avenue of approach, or a combination of these aspects.

b. **Effect.** This is the intended effect that the commander wants the obstacles and fires to have on the targeted enemy force. Tactical obstacles produce one of the following effects: block, turn, fix, or disrupt (Table 6-2, page 6-63). The obstacle effect drives integration, focuses subordinate fires, and focuses the obstacle effort.

c. **Relative Location.** The relative location is where the commander wants the obstacle effect to occur against the targeted enemy force. Whenever possible, the commander identifies the location relative to the terrain and maneuver or fire control measures to integrate the effects of obstacles with fires.

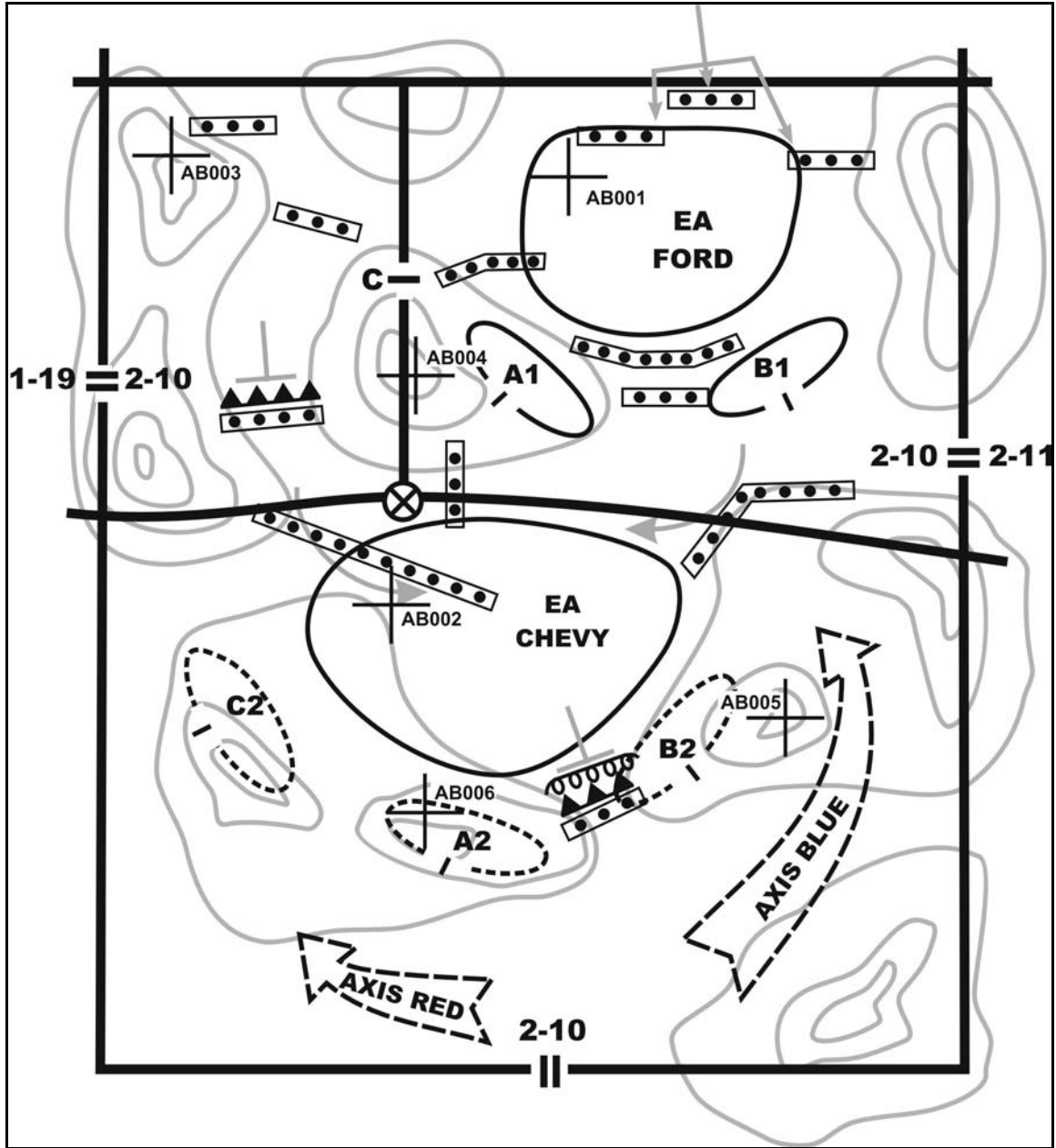






Figure 6-13. Example of a task force obstacle plan.

OBSTACLE EFFECT	PURPOSE	FIRES AND OBSTACLES MUST:	OBSTACLE CHARACTERISTICS
 <p><b>DISRUPT</b> ①</p>	<ul style="list-style-type: none"> <li>• Breakup enemy formations.</li> <li>• Interrupt the enemy's timetable and C2.</li> <li>• Cause premature commitment of breach assets.</li> <li>• Cause the enemy to piecemeal his attack.</li> </ul>	<ul style="list-style-type: none"> <li>• Cause the enemy to deploy early.</li> <li>• Slow part of his formation while allowing part to advance unimpeded.</li> </ul>	<ul style="list-style-type: none"> <li>• Do not require extensive resources.</li> <li>• Difficult to detect at long range.</li> </ul>
 <p><b>FIX</b> ②</p>	<ul style="list-style-type: none"> <li>• Slow an attacker within an area so he can be destroyed.</li> <li>• Generate the time necessary for the friendly force to disengage.</li> </ul>	<ul style="list-style-type: none"> <li>• Cause the enemy to deploy into attack formation before encountering the obstacles.</li> <li>• Allow the enemy to advance slowly in an EA or AO.</li> <li>• Make the enemy fight in multiple directions once he is in the EA or AO.</li> </ul>	<ul style="list-style-type: none"> <li>• Arrayed in depth.</li> <li>• Span the entire width of the avenue of approach.</li> <li>• Must not make the terrain appear impenetrable.</li> </ul>
 <p><b>TURN</b> ③</p>	<ul style="list-style-type: none"> <li>• Force the enemy to move in the direction desired by the friendly commander.</li> </ul>	<ul style="list-style-type: none"> <li>• Prevent the enemy from bypassing or breaching the obstacle belt.</li> <li>• Maintain pressure on the enemy force throughout the turn.</li> <li>• Mass direct and indirect fires at the anchor point of the turn.</li> </ul>	<ul style="list-style-type: none"> <li>• Tie into impassable terrain at the anchor point.</li> <li>• Consist of obstacles in depth.</li> <li>• Provide a subtle orientation relative to the enemy's approach.</li> </ul>
 <p><b>BLOCK</b> ④</p>	<ul style="list-style-type: none"> <li>• Stop an attacker along a specific avenue of approach.</li> <li>• Prevent an attacker from passing through an AO or EA.</li> <li>• Stop the enemy from using an avenue of approach and force him to use another avenue of approach.</li> </ul>	<ul style="list-style-type: none"> <li>• Prevent the enemy from bypassing or penetrating through the belt.</li> <li>• Stop the enemy's advance.</li> <li>• Destroy all enemy breach efforts.</li> </ul>	<ul style="list-style-type: none"> <li>• Must tie into impassable terrain.</li> <li>• Consist of complex obstacles.</li> <li>• Defeat the enemy's mounted and dismounted breaching effort.</li> </ul>

**Table 6-2. Obstacle effects.**

d. **Tactical Obstacles.** Obstacles are force-oriented combat multipliers. The task force employs tactical obstacles to influence the enemy's ability to move, mass, and reinforce directly. Tactical obstacles are integrated into the scheme of maneuver and fires to produce specific obstacle effects. Obstacles alone do not produce significant effects against the enemy; obstacles must be integrated with fires to be effective. The engineer section in Chapter 9 provides tables and specific information on engineer capabilities and obstacle effects. The following are the three types of tactical obstacles.

(1) **Directed.** The brigade directs obstacles as specified tasks to the task force through the use of obstacle belts. The task force may use the same technique, but more likely will be specific about the location and type of obstacle. The commander may use directed obstacles or obstacle groups to achieve specific obstacle effects at key locations on the battlefield. In this case, the staff plans the obstacle control measures and resources as well as determines measures and tasks to subordinates to integrate the directed obstacles with fires.

(2) **Situational.** Situational obstacles are obstacles that the brigade or task force plans and possibly prepares before an operation; however, they do not execute the obstacles unless specific criteria are met. Situational obstacles are "be-prepared" obstacles and

provide the commander flexibility for employing tactical obstacles based on battlefield developments. The commander may use engineer forces to emplace tactical obstacles rapidly, but more often he relies on scatterable mine systems. The brigade staff normally plans situational obstacles to allow the commander to shift his countermobility effort rapidly to where he needs it the most based on the situation. Execution triggers for situational obstacles are integrated into the decision support template (see Chapter 9, Section III, and FM 90-7, Chapter 7, for situational obstacles). Situational obstacles must be well integrated with tactical plans to avoid fratricide. Given the changes in engineer force structure, tactical concepts, and capabilities, situational obstacles are increasingly used instead of conventionally emplaced obstacles.

(3) **Reserve.** Reserve obstacles are obstacles for which the commander restricts execution authority. These are “on-order” obstacles. The commander specifies the unit responsible for constructing, guarding, and executing the obstacle. Examples of reserve obstacles include preparing a bridge for destruction or an obstacle to close a lane. Units normally prepare reserve obstacles during the preparation phase. They execute the obstacle only on command of the authorizing commander or when specific criteria are met. (See FM 90-7, Chapter 6, for specific considerations for planning reserve obstacles.) It is critical for the unit to understand and rehearse actions to execute reserve obstacles.

**NOTE:** In addition to tactical obstacles, units also employ protective obstacles. Protective obstacles are a key component of survivability operations, providing friendly forces with close-in protection. (See FM 90-7.)

e. **Obstacle Groups.** Obstacle groups are one or more individual obstacles grouped to provide a specific obstacle effect. TFs integrate obstacle groups to ensure that company teams plan individual obstacles that support the scheme of maneuver. Company teams integrate individual obstacles with direct and indirect fire plans to achieve the specified obstacle group effect.

(1) Obstacle groups normally attack the maneuver of enemy TFs. Normally, commanders plan obstacle groups along enemy battalion AAs as defined by company team mobility corridors. They may plan a group along a company-size AA. Unlike obstacle zones or belts, obstacle groups are not “areas” but are relative locations for obstacle construction. Obstacle groups are represented by obstacle effect symbols (block, fix, turn, disrupt) on TF graphics; however, commanders may refine obstacle group symbology with individual obstacle graphics if the plan requires specific obstacle types.

(2) TF commanders plan obstacle groups within assigned obstacle zones or belts. When given a belt with an assigned effect, the TF commander may use any combination of group effects if the sum effect of all groups achieves the overall effect of the belt.

(3) Obstacle groups impose strict limitations on company team commanders to preserve the link between obstacle effects and the fire plan. The limitations are similar to the limitations imposed by a BP. A group does not give the exact location of obstacles in the group just as a BP does not show the exact location of each weapon in the company team. The company team commander and the emplacing engineer coordinate these details directly. Company team commanders may make changes to obstacles and fire control measures based on the reality of the terrain. These changes must be coordinated with and

tracked by the TF commander and staff to maintain the fidelity of the desired obstacle group effect and integration into the TF scheme of maneuver.

(4) TFs do not normally assign a company team more than one obstacle group; however, a company team may effectively fight two groups at a time if the terrain supports it. To mass fires on an obstacle group, more than one company team often covers a single obstacle group within an EA. In these cases, the commander responsible for establishing the EA is also responsible for integrating the obstacle group. Normally, the TF commander or S3 plays a significant role in building and synchronizing an EA covered by two or more company teams.

(5) Obstacle groups, resource factors, and standard individual obstacles are the basis of TF obstacle logistics planning. They enable the commander and staff to allocate the necessary resources to each obstacle group, EA, or company team BP. These tools also enable the staff to identify critical shortfalls, plan the flow of materials within the TF area, and schedule resupply.

f. **Tactical Obstacle Planning.** Detailed obstacle planning begins during COA development. The engineer focuses on the following five specifics in his scheme of engineer operations (SOEO) for the obstacle plan.

(1) **Direct and Indirect Fire Analysis.** The direct and indirect fire analysis examines how engineers can best use obstacles to enhance the direct and indirect fire plan. The engineer must have a fundamental understanding of the direct and indirect fire and maneuver plans and the TF's organization of the EA to integrate obstacles effectively with the direct and indirect fire plan. The engineer must consider TF EAs, TRPs, indirect fire targets, unit locations, enemy formations, AAs, and the commander's obstacle intent in order to integrate obstacles effectively. Synchronization of direct and indirect fires with obstacles multiplies the relative effect on the enemy.

(2) **Obstacle Intent Integration.** The engineer plans directed obstacle groups during the COA development process. Obstacle groups integrated into the COA sketch graphically depict the commander's obstacle intent to support the maneuver plan. Obstacle groups target specific enemy elements based on the SITEMP. The engineer generally allocates an obstacle group against a TF-sized AA with respect to the EAs, TRPs, indirect fire targets, unit locations, enemy formations, and AAs assessed during the direct fire analysis. This process parallels the staff's placement of a company team against the same size enemy force. The intent of the obstacle group supports subordinate unit task and purpose. The engineer recommends specific obstacle group effects to the commander based on terrain, resources, time available, and the TF commander's obstacle intent.

(3) **Obstacle Priority.** The staff determines the priority of each obstacle group. The commander's intent and the most likely enemy COA clearly influence the priority. The obstacle priority should reflect the TF's most critical obstacle requirement. The TF engineer considers flank protection, weapons types and ranges, and the overall commander's intent for the entire force before placing obstacle priority on the main EA. Priorities assist the engineer in allocating resources and ensuring that the most critical obstacle groups are constructed first.

(4) **Mobility Requirements.** The engineer identifies TF mobility requirements by analyzing the scheme of maneuver, counterattack (CATK) options, reserve planning priorities, CS and CSS movement requirements, and adjacent and higher unit missions,

maneuver, and movement. The engineer integrates this analysis into obstacle group planning and avoids impeding friendly maneuver whenever possible. Because the bulk of the engineer force is committed to countermobility and survivability during defensive preparation, the TF commander uses clear obstacle restrictions on specific areas within the TF AO to maintain mobility. If obstacles must be constructed along a mobility corridor that primarily supports friendly movement, the TF must plan and rehearse a lane or gap and associated closure procedures. These lanes or gaps may be closed with situational or reserve obstacles.

(a) Beyond preparing and marking lanes and gaps through obstacles, engineers normally perform mobility tasks once defensive preparations are complete. Mobility assets may then be positioned to counter templated enemy situational obstacles, or be task organized to the reserve, CATK force, or any other unit that must maneuver or move subsequent to the execution of the defense. To do this effectively, the engineers and the supported maneuver unit must integrate, prepare, and rehearse. Since this manner of mobility support is critical to the success of the maneuver plan, timely linkup and coordination must be factored into the overall defensive preparation timeline.

(b) Sometimes the TF may require significant mobility support during defensive preparation. Examples may include route clearance, road repair or maintenance, and landing zone (LZ) and pickup zone (PZ) clearance. Brigade engineers are adequately resourced to perform this type of mobility support, but they clearly cannot concurrently prepare the defense and execute these tasks. Thus, the TF requires augmentation from a divisional multifunction engineer battalion. These engineers perform general engineering tasks, leaving the brigade engineers available to construct the TF defense.

#### **6-49. SURVIVABILITY**

Survivability operations in support of ground maneuver elements are increasingly limited given force structure and tactical concepts. Digging in combat vehicles is a technique that still has value in many situations, but the increasing need for mobility in defensive operations and the proliferation of precision munitions reduce the effectiveness of static, dug-in forces. Survivability efforts within the TF should focus on protection of assets that must remain relatively static (such as communication nodes), support of logistical and decontamination operations, and survivability for defending dismounted infantry.

---

## CHAPTER 7

# URBAN OPERATIONS

*Throughout history, military planners have viewed cities as centers of gravity and sources of national strength. Cities are population centers; transportation and communication hubs; key nodes of industrial, financial, and information systems; seats of government; and repositories of wealth. Because of the changing nature of society and warfare, deployments into urban environments have become more frequent, and this trend is likely to continue. The purpose of such deployments will be to neutralize or stabilize extremely volatile political situations, to defeat an enemy force that has sought protection afforded by urban terrain, or to provide assistance to allies in need of support. This chapter provides guidance necessary for planning and executing missions in an urban environment. The infantry brigade is the primary headquarters around which units are task organized to perform UO.*

### Section I. INTRODUCTION

Urban operations (UO) are defined as military operations conducted in a topographical complex and adjacent natural terrain where manmade construction and high population density are the dominant features. An urban area is a topographical complex where manmade construction and the population are the dominant features. Urban terrain confronts commanders with a combination of difficulties rarely found in other environments. Cities vary immensely depending on their history, the cultures of their inhabitants, their economic development, the local climate, available building materials, and many other factors. This variety exists not only among different cities but also within any particular urban area. The urban environment, like all environments, is neutral and affects all sides equally. The side that can best understand and exploit the effects of the urban area has the best chance of success.

#### 7-1. GENERAL CONSIDERATIONS OF URBAN OPERATIONS

The increasing world population and accelerated growth of cities makes UO in future conflicts very likely. Operations in urban areas usually occur when--

- The battalion task force is assigned an objective that is within an urban area.
- The urban area is key (or decisive) in setting or shaping the conditions for current or future operations.
- The urban area is in the path of a general advance and cannot be surrounded or bypassed.
- Political or humanitarian concerns require the control of an urban area or necessitate operations within it.
- Defending from urban areas supports a more effective overall defense or cannot be avoided.
- Occupation, seizure, and control of the urban area will deny the enemy control of the urban area and the ability to impose its influence on both friendly military forces and the local civilian population, thereby allowing friendly forces to retain the initiative and dictate the conditions for future operations.

a. **Organization.** While it is imperative for tanks and infantry to work closely together in urban terrain, a mechanized infantry-heavy battalion task force is better suited for urban operations because of the numerous infantry-specific tasks associated with conducting operations in urban terrain.

b. **Digitized Task Forces.** Digitized battalion task forces derive considerable advantages from their ABCS equipment. While the MCS and FFCB2 do not depict the multiple levels of urban fighting and do not show precise detail in built-up area (BUA) mapping, their ability to transfer information quickly and to maintain current information throughout the TF still represents a notable improvement over analog systems. When linked to a dismounted FFCB2, ABCS greatly enhances the combat effectiveness of Army combined arms teams and task forces in UO.

## 7-2. ARMOR AND MECHANIZED FORCES ROLE IN URBAN OPERATIONS

Although the close combat phase of urban operations is infantry-centric, armor and mechanized units operate as an integral force in urban operations. Armor and mechanized units are the optimal force to isolate or prevent isolation during urban operations. Secondly, armor and mechanized forces operate with infantry forces in the close fight by providing precise and overwhelming firepower and the ability to maneuver to gain a positional advantage over the enemy.

a. **Isolation.** As part of brigade shaping operations, isolation is defined as a tactical task to seal off an enemy from his sources of support, to deny freedom of movement, and prevent an enemy from having contact with other forces. Mechanized forces are well suited to execute this task because they possess the speed, firepower, and protection necessary to shape the urban area for offensive and defensive operations. If the attacker fails to isolate the urban area, the defender can reinforce and resupply his forces thus protracting the operation and significantly decreasing the attacker's resources and his will to continue. If the defender allows himself to be isolated, the attacker seizes the initiative and forces the defender to take risky actions (such as a breakout or counterattack) to survive.

b. **Close Combat.** Historically, the close fight in urban combat has consisted of street-to-street fighting resulting in high casualties and high expenditure of resources. Combined-arms forces use maneuver and situational understanding to position forces to accomplish their assigned missions in urban environments.

## 7-3. TACTICAL CHALLENGES

The battalion task force faces a number of challenges during the planning and execution of UO. The most likely challenges are discussed in the following paragraphs.

a. **Contiguous and Noncontiguous Areas of Operations.** The TF must be prepared to conduct UO operations in both contiguous and noncontiguous areas of operations.

(1) Contiguous operations are military operations that the TF conducts in an area of operations that facilitates mutual support of combat, CS, and CSS elements. Contiguous operations have traditional linear features including identifiable, contiguous frontages and shared boundaries between forces. For TFs, contiguous operations are characterized by relatively close distances among adjacent TFs, supporting brigade assets, and subordinate units and elements.



(2) In noncontiguous operations, the TF may be required to operate independently, removed from brigade CS and CSS assets by distance and time. Additionally, subordinate company teams may operate in isolated pockets, connected only through the integrating effects of an effective concept of operations. Noncontiguous operations place a premium on initiative, effective information operations, decentralized security operations, and innovative logistics measures. Noncontiguous operations complicate or hinder mutual support of combat, CS, and CSS elements because of extended distances between subordinate units and elements.

b. **Symmetrical and Asymmetrical Threats.** In addition to being required to face symmetrical threats, the TF must be prepared to face threats of an asymmetrical nature.

(1) Symmetrical threats are generally “linear” in nature and include those threats that specifically confront the TF’s combat power and capabilities. Examples of symmetrical threats include conventional enemy forces conducting offensive or defensive operations against friendly forces.

(2) Asymmetrical threats are those that are specifically designed to avoid confrontation with the TF’s combat power and capabilities. These threats may use the civilian population and infrastructure to shield their capabilities from TF fires. Asymmetrical threats may attack both the TF and civilian population with WMD. Asymmetrical threats are most likely to target and be based in urban areas to take advantage of the density of civilian population and infrastructure. Examples of asymmetrical threats include terrorist attacks, electronic warfare (to include computer-based systems), criminal activity, guerrilla warfare, and environmental attacks.

c. **Quick Transition from Stability or Support Operations to Combat Operations and Back.** Stability and, to a lesser extent, support operations are missions that may transition to combat. The TF must always retain the ability to conduct offensive and defensive operations. Preserving the ability to transition allows the TF to maintain initiative while providing force protection. Commanders should consider planning a defensive contingency with on-order offensive missions in case stability and support operations deteriorate. Subordinate commanders and leaders must be fully trained to recognize activities that would initiate this transition.

d. **Rules of Engagement.** Urban operations are usually conducted against enemy forces fighting in close proximity to civilians. Rules of engagement and other restrictions on the use of combat power are more restrictive than in other conditions of combat (see FM 3-06.11 ).

## **Section II. MISSION, ENEMY, TERRAIN AND WEATHER, TROOPS AND SUPPORT AVAILABLE, TIME AVAILABLE, AND CIVIL CONSIDERATIONS (METT-TC)**

Planning and preparation for UO are generally the same as for operations on open terrain; however, IPB is disproportionately important due to the complexity of urban terrain. In order for the commander and staff to develop an effective COA, the force must conduct aggressive ISR operations. Urban operations require significant human intelligence (HUMINT) reconnaissance because sensors and other technological devices are not as effective in urban environments. ISR operations can take the form of stealthy surveillance teams, tactical questioning of noncombatants, and reconnaissance of key terrain and avenues of approach. Using ISR assets and satellite imagery, the staff can develop urban

maps that include a common reference system (such as numbering buildings) to assist subordinate units' C2. The commander and staff must also take into account special considerations when operating in this environment. This section provides special METT-TC considerations for UO.

#### 7-4. MISSION

The TF must close with and defeat the enemy in order to be decisive in urban operations. Close combat in urban operations is resource intensive, requires properly trained and equipped forces, and has the potential for high casualties. Therefore, the TF must use close combat as its decisive operation only after shaping the urban area through aggressive ISR, isolation, precision fires, and maneuver.

a. **Objective.** The commander and staff must clearly understand the purpose of the operation. The TF's objective may be terrain- or force-oriented. The commander must consider whether committing his force to combat in urban areas is required or beneficial for achieving his intent.

b. **Intent.** During planning for offensive operations, the commander and staff must consider the overall purpose and intent of the operation and define what is required. For example, the commander must determine if clearing means every building, block by block, or seizure of a key objective which may require clearing only along the axis of advance. Often, the TF can integrate urban areas into the defensive scheme to develop a stronger defense.

#### 7-5. ENEMY

The TF commander and staff must consider the strength, composition, disposition, and activities of the enemy. They must consider both conventional and unconventional enemy forces and the tactics the enemy may employ. Enemy tactics may range from ambushes and snipers to large-scale conventional actions conducted by heavy forces. The IPB must address the known and potential tactics and vulnerabilities of all enemy forces and threats operating within and outside the urban area. The IPB must consider the three-dimensional environment of urban areas: airspace, surface, and subsurface. It should also consider the political, racial, ethnic, tribal, and religious factors that influence the enemy. (See FM 34-130 for a detailed discussion of urban IPB.)

a. The increasing availability of sophisticated technology has created unorthodox operational approaches that can be exploited by potential opponents. These approaches seek to counter the technological and numerical advantages of US joint systems and forces and to exploit constraints placed on US forces due to cultural bias, media presence, ROE, and distance from the crisis location.

b. Offsetting their inherent weaknesses, enemy forces seek an advantage in urban terrain to remain dispersed and decentralized, adapting their tactics to provide them the best success in countering a US response. Threats, in addition to conventional forces, may consist of--

- Unconventional forces.
- Paramilitary forces.
- Militia and special police organizations.
- Organized crime organizations.

c. These forces range from units equipped with small arms, mortars, machine guns, antiarmor weapons, and mines to very capable mechanized and armor forces equipped with current generation equipment. Urban environments also provide many passive dangers such as disease from unsanitary conditions and psychological illnesses. While the active threats vary widely, many techniques are common to all. The enemy may employ a series of threat tactics during urban operations (Figure 7-1).



**Figure 7-1. Enemy threat tactics.**

(1) *Use the Population to Advantage.* The populace of a given urban area represents key terrain; the side that manages it best has a distinct advantage. Future urban battles may see large segments of the populace remain in place. TFs involved in urban operations must conduct missions in and among the residents of the area.

(a) Enemy forces may use the population to provide camouflage, concealment, and deception for their operations. Guerrilla and terrorist elements may look no different from any other members of the community. Even conventional and paramilitary troops may have a “civilian” look. Western military forces adopted the clean-shaven, close-cut hair standard at the end of the nineteenth century to combat disease and infection, but twenty-first century opponents might very well sport beards as well as civilian-looking clothing and other “nonmilitary” characteristics.

(b) The civilian population may also provide cover for enemy forces, enhancing their mobility close to friendly positions. Enemy forces may take advantage of US moral responsibilities and attempt to make the civilian population a burden on the Army’s

logistical and force protection resources. They may herd refugees into friendly-controlled sectors, steal from US-paid local nationals, and hide among civilians during offensive operations.

(c) The civilian population may also serve as an important intelligence source for the enemy. Enemy forces may manipulate local hires serving among US soldiers, civilians with access to base camp perimeters, and refugees moving through friendly-controlled sectors to provide information on friendly dispositions, readiness, and intent. In addition, enemy special purpose forces and hostile intelligence service assets may move among well-placed civilian groups.

(2) **Win the Information War.** Enemy forces may try to win the information war in direct opposition to the TF's operations.

(a) Portable video cameras, Internet access, commercial radios, and cellular telephones are all tools that permit enemy forces to tell their story. American "atrocities" may be staged and broadcast. Electronic mail may be transmitted to sympathetic groups to help undermine resolve. Internet websites provide easy worldwide dissemination of enemy propaganda and misinformation. Hackers may gain access to US sites to manipulate information to the enemy's advantage.

(b) The enemy may make skillful use of the news media. Insurgent campaigns, for example, need not be tactical military successes; they need only make the opposition's campaign appear unpalatable to gain domestic and world support. The media coverage of the Tet Offensive of 1968 affected the will of both the American people and their political leadership. Although the battle for Hue was a tactical victory for the US, the North Vietnamese clearly achieved strategic success by searing the American consciousness with the high costs of urban warfare.

(3) **Manipulate Key Facilities.** Enemy forces may identify and quickly seize control of critical components of the urban area to help them shape the battlespace to their own ends. Telephone exchanges provide simple and reliable communications that can be easily secured with off-the-shelf technologies. Sewage treatment plants and flood control machinery can be used to implement WMD strategies or to make sections of the urban area uninhabitable. Media stations significantly improve the information operations of the controlling force. Power generation and transmission sites provide a means to control significant aspects of civilian society over a large area.

(4) **Use the Three Dimensions of Urban Terrain.** The enemy thinks and operates throughout all dimensions of the urban environment. Upper floors and roofs provide the urban enemy forces excellent observation points and battle positions above the maximum elevation of many weapons. Shots from upper floors strike friendly armored vehicles in vulnerable points. Basements also provide firing points below many weapons' minimum depressions and strike at weaker armor. Sewers and subways provide covered and concealed access throughout the area of operations. Conventional lateral boundaries often do not apply as enemy forces control some stories of a building while friendly forces control other stories of the same building.

(5) **Employ Urban-Oriented Weapons.** Whether they are purpose-built or adapted, many weapons may have greater than normal utility in an urban environment while others may have significant disadvantages. Urban enemy weapons are much like the nature of urbanization and the urban environment: inventive and varied. Small, man-

portable weapons, along with improvised munitions, can dominate the urban environment. Examples of enemy weapons favored in UO are--

- Weapons with no minimum depression or no maximum elevation.
- Weapons with little or no backblast (gas-metered, soft launch, and so on).
- Mortars.
- Sniper rifles.
- Machine guns.
- Grenades.
- Grenade launchers.
- Flame and incendiary weapons.
- Rocket-propelled grenades (RPGs) and other shoulder-fired antitank guided missiles (ATGMs).
- Riot control and tranquilizer gases.
- Mines and booby-traps.

(6) ***Engage the Entire Enemy Force.*** Enemy forces may “hug” TFs operating in an urban area to avoid the effects of high-firepower standoff weapons systems. They may also try to keep all or significant portions of the TF engaged in continuous operations to increase the TF's susceptibility to stress-induced illnesses. UO, by their nature, produce an inordinate amount of combat stress casualties, and continuous operations exacerbate this problem. The enemy may maintain a large reserve to minimize the impact of this on its own forces.

(7) ***Focus Attacks on Service Support and Unprotected Soldiers.*** Enemy forces may prey on soldiers poorly trained in basic infantry skills. Ambushes may focus on these soldiers while they are conducting resupply operations or moving in poorly guarded convoys. Urban operations are characterized by the isolation of small groups and navigational challenges, and the enemy may use the separation this creates to inflict maximum casualties even when there is no other direct military benefit from the action.

## 7-6. URBAN MAPPING

Prior to entering an urban environment, the battalion task force obtains or develops urban maps to assist in C2. The brigade should attempt to gain access to city planner or civil engineer maps to provide detailed information on the urban area. The urban maps, whether digital or sketched, include a reference system to identify buildings and streets (Figure 7-2, page 7-8). Naming conventions should be simple to allow for ease of navigation and orientation in the urban environment (odd number buildings on left side of street, even numbers on right side). Street names should not be used as references because the enemy can remove or change street signs to confuse friendly forces.

a. Initial map and aerial photograph reconnaissance can identify key terrain and other important locations in the AO. These include--

(1) ***Safe Havens.***

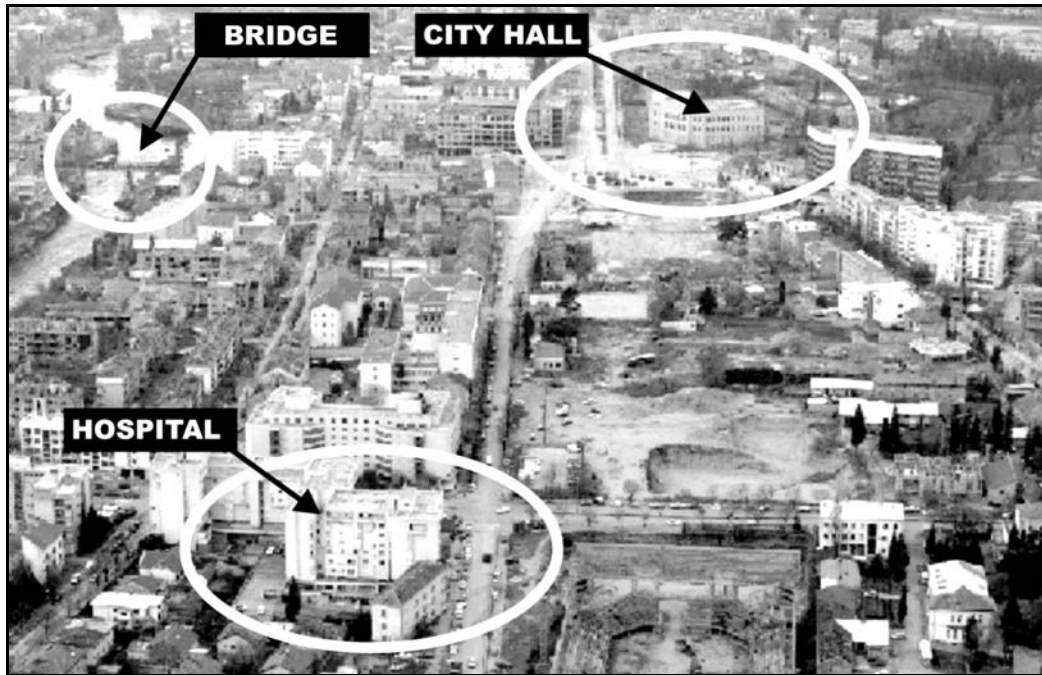
- Hospitals.
- Police stations.
- Embassies.
- Other (friendly) facilities.

(2) *Hazardous Areas.*

- Construction sites.
- Dangerous intersections.
- Bridges.
- Areas of high crime.

(3) *Major Terrain Features.*

- Parks.
- Industrial complexes.
- Airports.



**Figure 7-2. Initial photo reconnaissance of urban area of operations.**

b. The urban map also facilitates control by tracking units with greater detail and obtaining precise location updates when digital systems (which produce the common operating picture) may be affected by urban terrain. The TF uses ISR assets to confirm and update its urban maps. These improved maps are critical since most existing maps do not provide the level of detail necessary to conduct tactical operations. Specifically, the brigade assesses avenues of approach in the urban AO. Included with the maps are overlays that categorize sections of the urban area by ethnicity, religious affiliation, and other prevailing characteristics that could affect operations (Figure 7-3; Figure 7-4, page 7-10; and Figure 7-5, page 7-11).

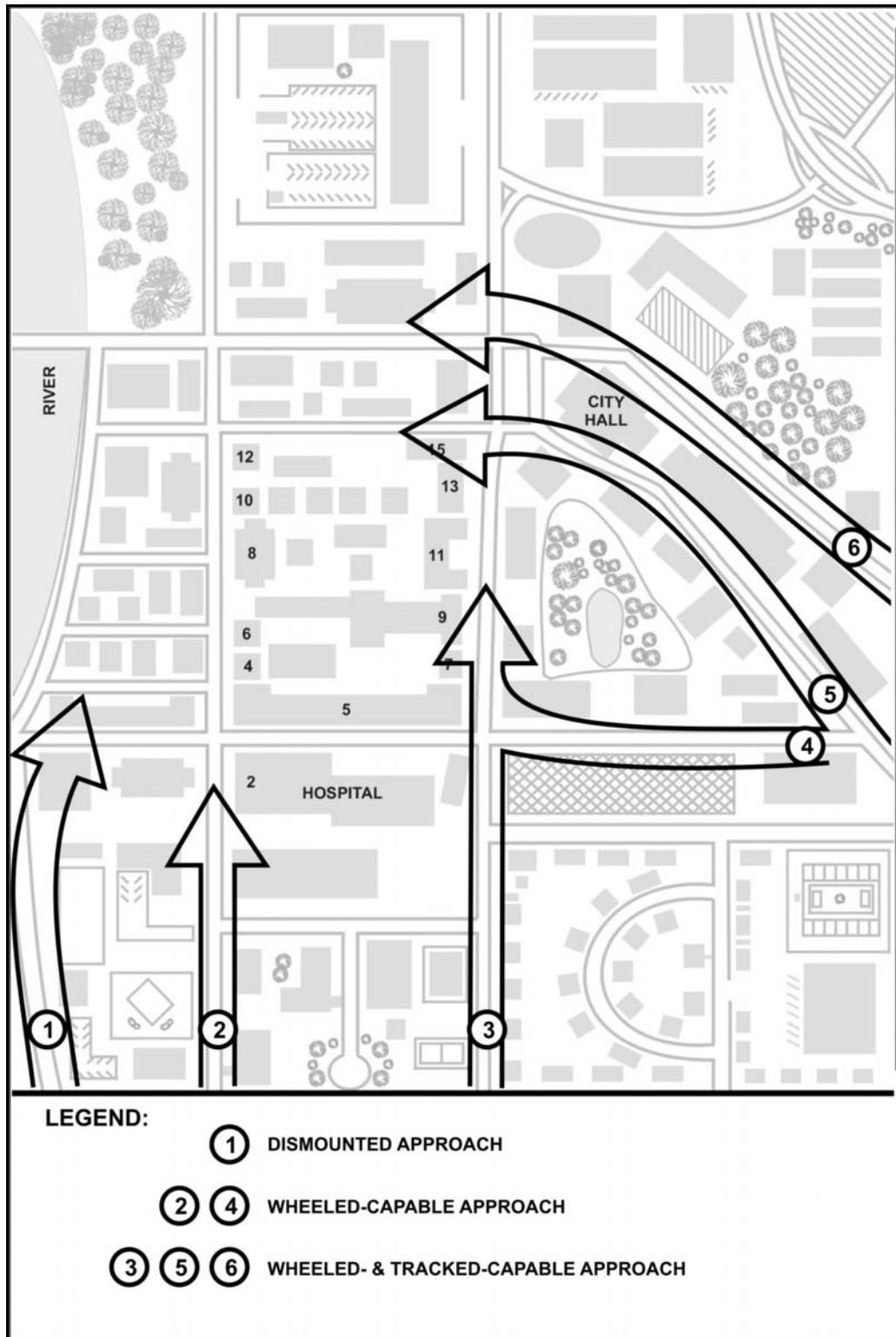


Figure 7-3. Avenues of approach in the urban area.

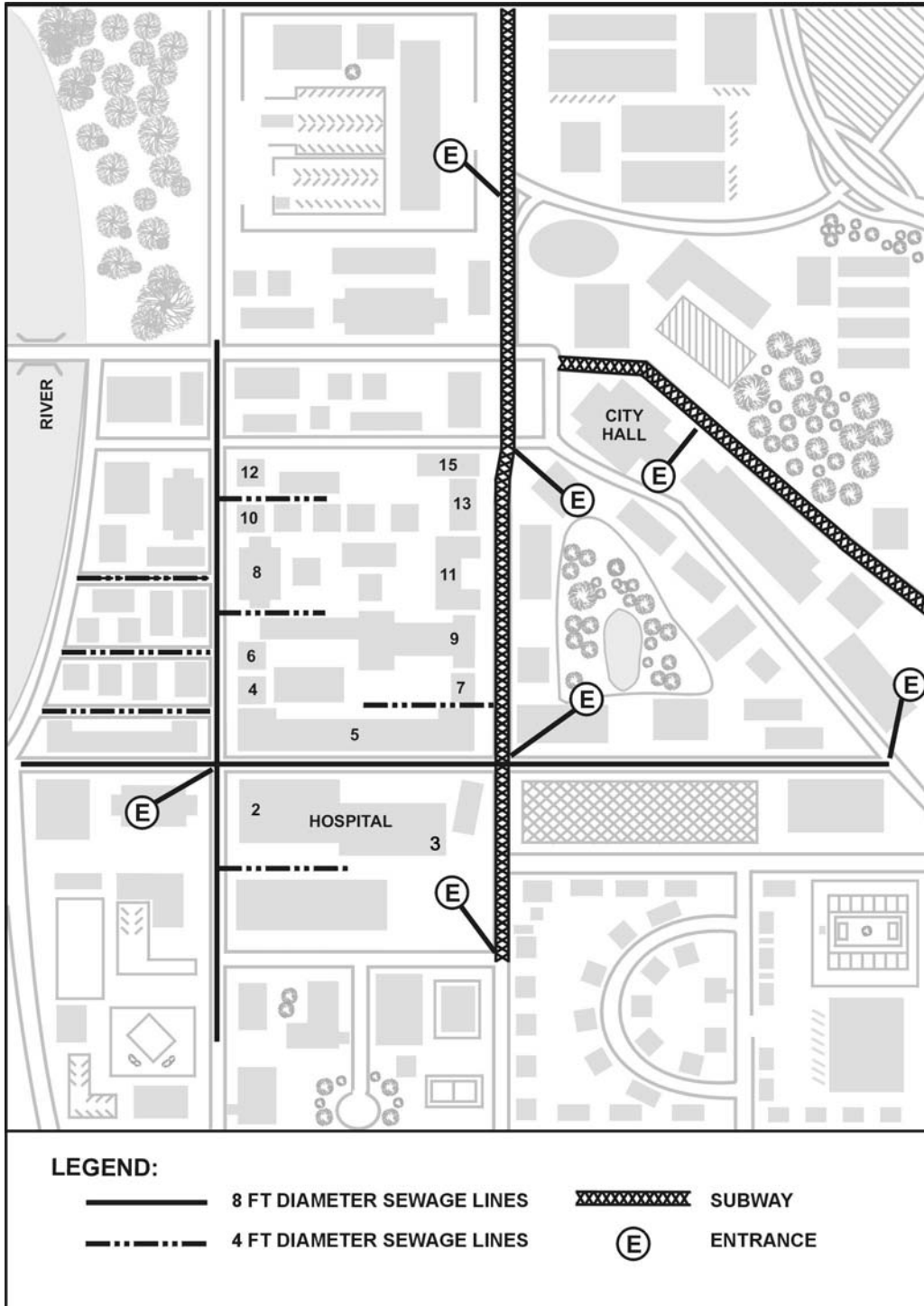


Figure 7-4. Sewer and subterranean overlay.



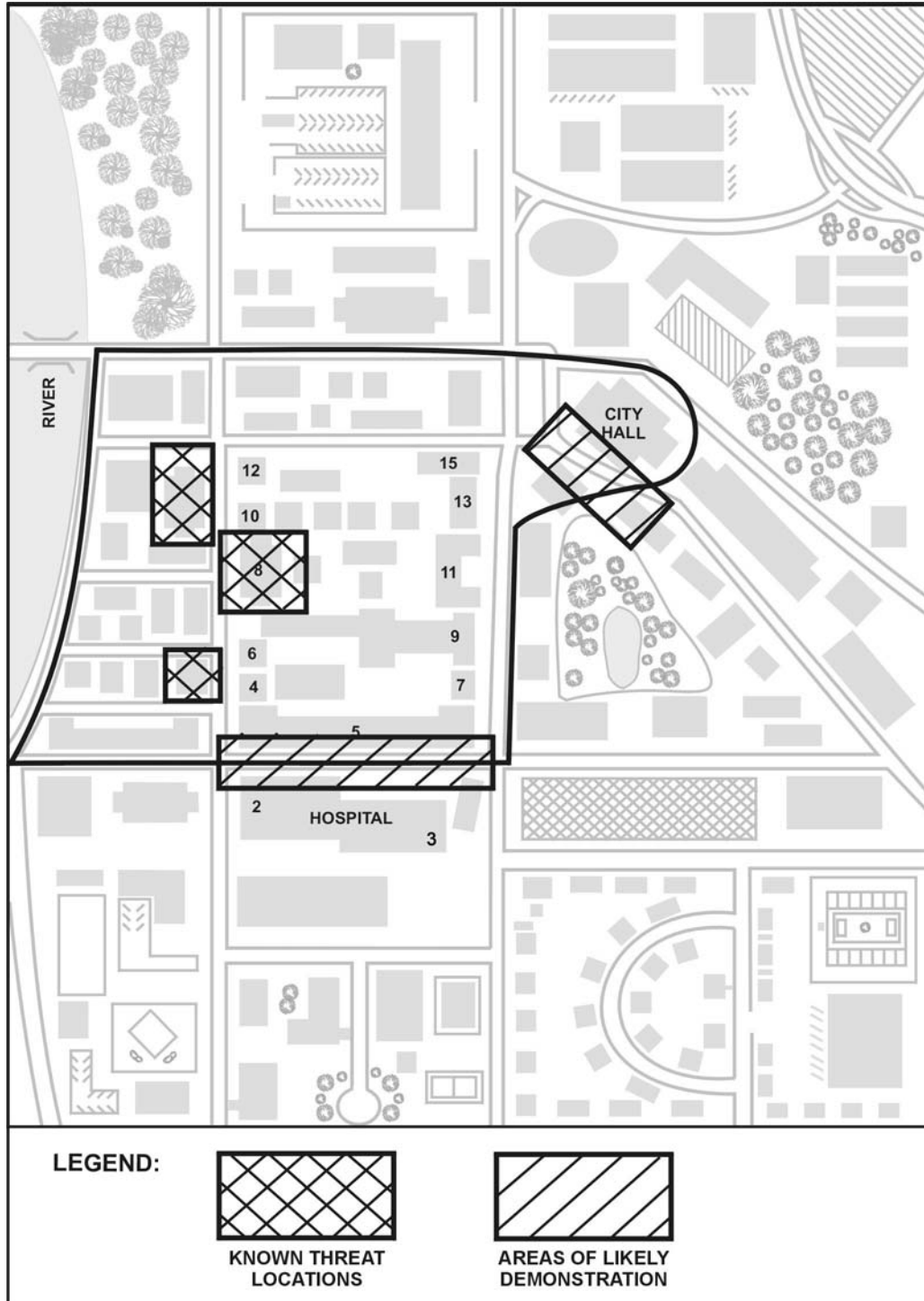


Figure 7-5. Enemy overlay.

**7-7. TERRAIN AND WEATHER**

An urban area is a concentration of structures, facilities, and people that form the economic and cultural focus for the surrounding area. TF operations are affected by all categories of urban areas (Table 7-1, page 7-12). Cities, metropolises, and megalopolises with associated urban sprawl cover hundreds of square kilometers. TFs normally operate

in these urban areas as part of a larger force. Extensive combat in these urban areas involves units of division level and above.

<b>Villages</b> (Population of 3,000 inhabitants or less)	The TF's AO may contain many villages. TFs and company teams bypass, move through, defend from, and attack objectives within villages as a normal part of brigade operations.
<b>Towns</b> (Population over 3000 up to 100,000 inhabitants)	Operations in such areas normally involve brigades or divisions. TFs may bypass, move through, defend in, or attack enemy forces in towns as part of division operations. Operations in these areas normally require the full commitment of brigades or divisions.
<b>Cities</b> (Population of 100,000 to 1 million inhabitants)	Extensive combat in large cities involves divisions and larger formations. TFs may fight adjacent to, on the edges of, or inside cities.
<b>Metropolis</b> (Population over 1 million to 10 million)	Extensive combat in large cities involves divisions and larger formations. TFs may fight adjacent to, on the edges of, or inside cities.
<b>Megalopolis</b> (Population over 10 million inhabitants)	Extensive combat in large cities involves divisions and larger formations. TFs may fight adjacent to, on the edges of, or inside cities.

**Table 7-1. Categories of urban areas.**

a. **Terrain.** A detailed analysis of the urban area and surrounding terrain is vital to the success of any operation in an urban area (see FM 34-1). The TF commander must understand the elements of the urban infrastructure that are necessary for achieving the intent and end state of the brigade's mission. Military maps normally do not provide sufficient detail for terrain analysis of an urban area. Recent aerial photographs and other current intelligence products are critical. Maps and diagrams of the city from other sources, such as local governments, tourist activities, or law enforcement services, can be useful. Products developed by the National Imagery Mapping Agency (NIMA) can be specifically tailored for the area of operations.

(1) The S2 should obtain maps and diagrams of the following:

- Subway systems, railways, and mass transit routes.
- Underground water, sewer, and utility systems.
- Electrical distribution systems, power stations, and emergency services.
- Fuel supply and storage facilities.
- Facilities for mass communications, such as cellular phones, computer hubs, radios, and telephones.
- Public administration buildings, hospitals, and clinics.

(2) The terrain analysis should also identify the following:

- Structural characteristics of buildings, bridges, and transportation networks.
- Roads, highways, rivers, streams, and other waterways that may be used as high-speed avenues of approach.
- Analysis of the natural terrain surrounding the urban area (observation and fields of fire, cover and concealment, obstacles, key terrain, and avenues of approach [OCOKA]).
- Analysis of the urban area itself to include street patterns, structure types, and available maneuver space. (See FM 34-130.)
- Covered and concealed approaches to the urban area.
- Key and decisive terrain inside and outside the urban area.
- Identification of buildings, areas, or facilities protected by the law of land warfare or restricted by current ROE (such as churches, medical facilities, historic monuments, and other facilities dedicated to arts and sciences), provided they are not being used for military purposes. (See FM 27-10.)
- Stadiums, parks, open fields, playgrounds, and other open areas that may be used for landing zones or holding areas.
- Locations of prisons and jails.
- Potential host nation support facilities such as quarries, lumber yards, major building supply companies, and warehouses.
- Power lines, telephone lines, and raised cables that may be hazards to helicopters.
- Significant fire hazards and locations of toxic industrial materials (TIM).
- Weather effect products from topographic models or historical sources (for example, effects of heavy rains on local areas).

(3) A close relationship with the local government and military forces can be very beneficial. They can provide information about population, fire-fighting capabilities, locations of TIM, police and security capabilities, civilian evacuation plans, location of key facilities, and, possibly, current enemy activities. They may also be able to provide translators.

(4) An infrastructure analysis of the urban area is also important. Because urban infrastructures vary greatly, a comprehensive list cannot be provided. However, common characteristics include--

- Urban street patterns and trafficability.
- Sources of potable water.
- Bulk fuel and transport systems.
- Communications systems.
- Rail networks, airfields, canals and waterways, and other transportation systems.
- Industries.
- Power (to include nuclear) and chemical production facilities and public utilities.

b. **Weather.** Weather analyses that are important to TF operations include visibility, winds, precipitation, and temperature and humidity.

(1) **Visibility.** Light data have special significance during urban operations. Night and periods of reduced visibility (including fog) favor surprise, infiltration, detailed reconnaissance, attacks across open areas, seizure of defended strongpoints, and reduction of defended obstacles. However, the difficulties of night navigation in restricted terrain, without reference points and near the enemy, forces the TF to rely on simple maneuver plans with easily recognizable objectives.

(2) **Winds.** Wind chill is not as pronounced in urban areas. However, the configuration of streets, especially in close-orderly block and high-rise areas, can cause wind canalization. This increases the effects of the wind on streets that parallel the wind direction while cross-streets remain relatively well protected. Because of these factors, swirling winds occur and the wind speed and direction may continually change. This factor also affects the use of smoke for both friendly and enemy forces. Downwind predictions for NBC and TIM are also difficult.

(3) **Precipitation.** Rain or melting snow often floods basements and subterranean areas, such as subways, and also makes storm and other sewer systems hazardous or impassable. Chemical agents and other TIM are washed into underground systems by precipitation. As a result, these systems may contain toxic concentrations much higher than surface areas and may become contaminated “hot spots.” These effects become more pronounced as chemical agents or TIM are absorbed by brick or unsealed concrete sewer walls.

(4) **Temperature and Humidity.** Air inversion layers are common over cities, especially cities located in low-lying “bowls” or in river valleys. Inversion layers trap dust, chemical agents, and other pollutants, reducing visibility and often creating a greenhouse effect which causes a rise in ground and air temperature. The heating of buildings during the winter and the reflection and absorption of summer heat make urban areas warmer than surrounding open areas during both summer and winter. This difference can be as great as 10 to 20 degrees and can add to the already high logistics requirements of urban combat. Summer heat, combined with the very physical requirements of urban combat, can cause severe heat-related injuries. Changes in temperature as a result of air inversions can also affect thermal sights during crossover periods of warm to cold and vice versa.

## **7-8. TROOPS**

During UO, the TF is often augmented with additional assets, which may include engineers, ADA, and light infantry. Army aviation, FA, MP, public affairs, PSYOP, civilian affairs, smoke, decontamination, and long-range surveillance (LRS) assets, when available, may also support the TF under brigade control. (Figure 7-6, page 7-18, shows a sample task organization.) Actual task organizations depend on the factors of METT-TC.

a. **Troop Density, Equipment, and Ammunition.** Troop density for offensive missions in urban areas can be as much as three to five times greater than for similar missions in open terrain. Troops require additional equipment such as ladders, ropes, grappling hooks, and other entry equipment. The ammunition consumption rates for small arms, grenades (all types), Claymore mines, ATGMs, 25-mm and 120-mm high-explosive (HE), and explosives can be four times the normal rate. The staff must ensure the continuous supply of Classes I, III, V, and VIII and water to forward units. Supplies

should be configured for immediate use and delivered as far forward as possible to supported units.

b. **Stress.** The commander and staff must consider the effects of prolonged combat on soldiers. The battalion surgeon must ensure that he participates in the early planning for operations in the urban area. To develop a comprehensive, effective, and synchronized HSS plan, the battalion surgeon must know and understand the battalion commander's intent and guidance. Further, the battalion surgeon and the medical platoon personnel must be included in the combined arms rehearsal to ensure the HSS plan is synchronized with the tactical plan. See FM 4-02.4 for information on HSS support in urban operations. Continuous close combat produces high psychological stress and physical fatigue. Rotating units committed to combat for long periods can reduce stress. Leaders should take extra effort and time to train and psychologically prepare soldiers for this type of combat.

c. **Discipline.** Maintaining discipline is especially important in UO. All commanders must ensure their soldiers understand and follow the established ROE. The law of land warfare prohibits unnecessary injury to noncombatants and needless damage to property. This may restrict the commander's use of certain weapons, munitions, and tactics.

## 7-9. TIME

Combat in urban areas has a slower tempo and increased use of methodical, synchronized missions. In planning UO, the commander and staff must take these factors into account. Planning must allow more time for thorough reconnaissance, subordinate unit rehearsals, sniper and countersniper operations, demolitions, breaching, fire fighting, entry and movement techniques, fighting position construction, booby trap recognition and neutralization, combat lifesaver training, and crowd control.

## 7-10. CIVIL CONSIDERATIONS

The commander and staff must understand the composition, activities, and attitudes of the civilian population within the urban area to include the political infrastructure. Various options are available to the commander to control the impact of civilians on the operation. These include screening civilians, prohibiting unauthorized movement, diverting or controlling refugee movements, and evacuating. Understanding the urban society requires comprehension of--

- Living conditions.
- Cultural distinctions.
- Ethnicity.
- Factions.
- Religious beliefs.
- Political affiliation
- Grievances.
- Attitudes toward US forces (friendly, hostile, or neutral).

a. **Curfew and Evacuation.** A commander with the mission of defending an urban area may need to establish a curfew to maintain security or to aid in control of military traffic. (Curfews are not imposed as punishment. They are normally established to reduce noncombatant casualties and provide a measure of force protection.) A commander can require civilians to evacuate towns or buildings if the purpose of the evacuation is to use

the town or building for imperative military purposes, to enhance security, or to safeguard those civilians being evacuated. If the commander takes this action, he must specify and safeguard the evacuation routes. TFs may also be involved in securing routes and possibly safeguarding food, clothing, and medical and sanitary facilities. Evacuated civilians must be transferred back to their homes as soon as hostilities in the area have ceased. The staff must plan for and coordinate the movement and evacuation of civilians to ensure their actions do not interfere with the military operation. The TF staff and supporting civil affairs units working with local officials coordinate the movements of civilians.

b. **Resistance Groups.** The TF may encounter civilian resistance groups whose actions may range from providing the enemy with supplies, services, and noncombatant support to actively fighting against friendly forces. Members of such resistance groups should be dealt with in accordance with applicable provisions of the law of war. Commanders should seek guidance from the judge advocate general (JAG) concerning the detention and disposition of persons participating in acts harmful to friendly forces. The S2 must work with PSYOP and civil affairs units to identify these threats and recommend, within the ROE, the appropriate preemptive action or response. The activities of resistance groups may also benefit friendly forces. They may provide HUMINT; act as guides, liaisons, or translators; and provide subject-matter expertise on local public facilities such as refineries, power plants, and water works. They may also provide active resistance against the enemy.

### **Section III. CONTROLLING OPERATIONS**

Urban operations require centralized planning and decentralized execution. Therefore, the staff must develop a detailed plan that synchronizes the battlefield operating systems in order to meet the commander's intent and provide subordinate units with the means to accomplish the mission.

#### **7-11. ENEMY FOCUS**

During the mission analysis, the plan should focus on the factors of METT-TC. Orient the plan on the enemy rather than the terrain. Use terrain factors to defeat the enemy. Considerations include, but are not limited to, the following:

- a. Thorough evaluation of the urban area's related terrain and enemy may take much longer than in other environments. This time factor also affects friendly planning efforts.
- b. Determine the enemy's location, strength, and capabilities. Develop a plan that defeats his direct and indirect fire systems.
- c. Focus the axis of advance on the enemy's weaknesses while maintaining adequate force protection measures. When possible, employ multiple and supporting axes of advance.
- d. Divide the objective area into manageable smaller areas that facilitate company team maneuver.
- e. Isolate the objective area and establish a foothold at the point of entry. The location chosen for the foothold must allow for expansion.
- f. The brigade and TF maneuver plans directly affect the company team schemes of maneuver. Every platoon within the TF must know what enemy targets will be engaged by brigade and TF assets.

## 7-12. COMMANDER'S CRITICAL INFORMATION REQUIREMENTS

The CCIR directly affect a commander's decisions and dictate the successful execution of tactical operations. The TF staff must develop the components of the CCIR that facilitate the commander's ability to make decisions affecting the plan during urban operations. Essential elements of friendly information are not part of CCIR, although they become a commander's priorities when he states them. EEFI help commanders understand what enemy commanders want to know about friendly forces and why. They tell the commander what cannot be compromised. Friendly forces information requirements (FFIR) are information that the commander and staff need about the forces available for the operation. The following are examples of PIR, EEFI, and FFIR that would help the commander in an urban environment.

a. **Priority Information Requirements.** PIR are intelligence requirements that a commander has anticipated and that have stated priority in task planning and decision making. Examples include the following:

- Is the enemy using avenue of approach one to infiltrate into the TF area of operations?
- Does mobility corridor three (Third Street) restrict movement of friendly armored and wheeled vehicles?
- Is there an enemy strongpoint located between Third Street and Fifth Street along Third Avenue?
- Does the enemy have ADA assets positioned along air avenue of approach two?

b. **Essential Elements of Friendly Information.** EEFI are critical aspects of a friendly operation that, if known by the enemy, would subsequently compromise, lead to failure, or limit the success of the operation. Therefore, they must be protected from detection. Examples include the following:

- Have any of the TF command nets been compromised?
- Has the LOC been disrupted and if so, where?
- Has the enemy located my Q36?

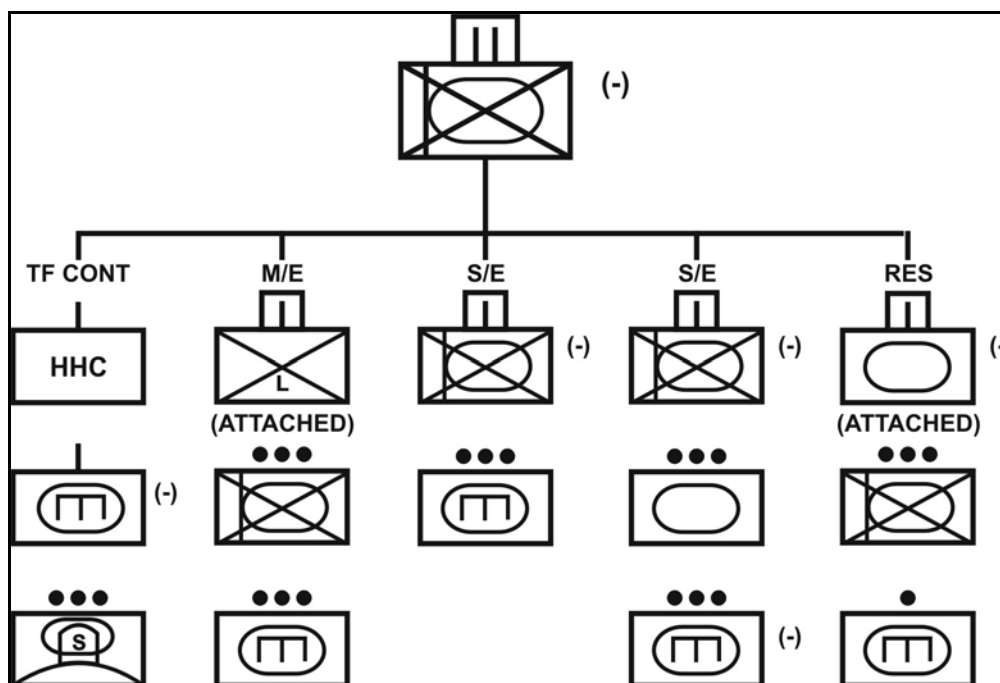
c. **Friendly Forces Information Requirements.** FFIR are information the commander and staff need about the friendly forces available for the operation. Examples include the following:

- Scouts captured or compromised.
- Main bridge locations along the ground route that have been blown.
- OPORD compromised.
- Loss of cryptographic equipment.
- Expected personnel and equipment replacements that did not arrive.

## 7-13. TASK-ORGANIZATION OF UNITS TO ACCOMPLISH SPECIFIC TASKS

Urban operations may require unique task organizations (Figure 7-6). For example, urban operations provide one of the few situations where infantry and armor elements may be effectively task organized below platoon levels. TF commanders must consider providing assets where they will be needed to accomplish specific tasks. All phases of mission execution must be considered when developing task organization. Changes in task organization may be required to accomplish different tasks during mission execution.

Figure 7-6 depicts a sample task organization for a mechanized infantry TF conducting offensive urban operations that consists of a main effort, two supporting efforts, and a reserve.



**Figure 7-6. Sample offensive task organization.**

**NOTE:** The task organization shown in Figure 7-6 may change after the assault when the TF reorganizes for follow-on missions.

#### 7-14. REHEARSALS

After developing a thorough, well-synchronized plan, TF commanders should require subordinate units to conduct combined arms rehearsals at the levels at which the operations will occur, to include all phases of the operation. When conducted properly, combined arms rehearsals identify potential problems in synchronization among maneuver, combat support, and combat service support elements. Rehearsals provide a means for units that seldom operate together to train collective skills. Rehearsals should start early in the troop-leading process. Some rehearsals can start shortly after receipt of warning orders. Subordinate units can rehearse drills, such as breaching, clearing buildings, and moving between buildings, before receiving a detailed plan. Infantry can also rehearse aspects of operating close to armored vehicles. The TF commander and staff must allocate sufficient time to subordinate units to conduct rehearsals. Rehearsals for subordinate units to consider include, but are not limited to, the following:

- Communications procedures.
- Direct fire control plan.
- Fires (lethal and nonlethal effects).
- Breaching.
- Maneuver.



### 7-15. FIRE SUPPORT

Often, the role of fires in UO is to get the maneuver force into or around the urban area with minimal casualties so that the commander has the maximum combat power to close with the enemy and finish the fight. The fire support officer develops EFSTs to support the maneuver plan. The fire support officer may also plan and coordinate nonlethal capabilities for the TF commander. Civil affairs and PSYOP assets should be coordinated with the appropriate command and control warfare or information operations planning headquarters. When planning the use of mortars, commanders must consider the following. (See FM 3-06.11, Appendix K, for additional TTP.)

- FOs should be positioned where they can get the maximum observation so target acquisition and adjustments in fire can best be accomplished. This is not necessarily on tops of buildings.
- Commanders must understand ammunition effects to correctly estimate the number of volleys needed for the specific target coverage. Also, the effects of using white phosphorus (WP) or red phosphorus may create unwanted smoke screens or limited visibility conditions that could interfere with the tactical plan.
- FOs must be able to determine dead space in urban terrain. Dead space is the area in which indirect fires cannot reach the street level because of buildings. This area is a safe haven for the enemy. For mortars, the dead space is about one-half the height of the building (Figure 7-7).
- Mortar crews should plan to provide their own security.
- Commanders must give special consideration to where and when mortars are to displace while providing immediate indirect fires to support the overall tactical plan. Combat in urban areas adversely affects the ability of mortars to displace because of rubble and the close nature of urban combat.

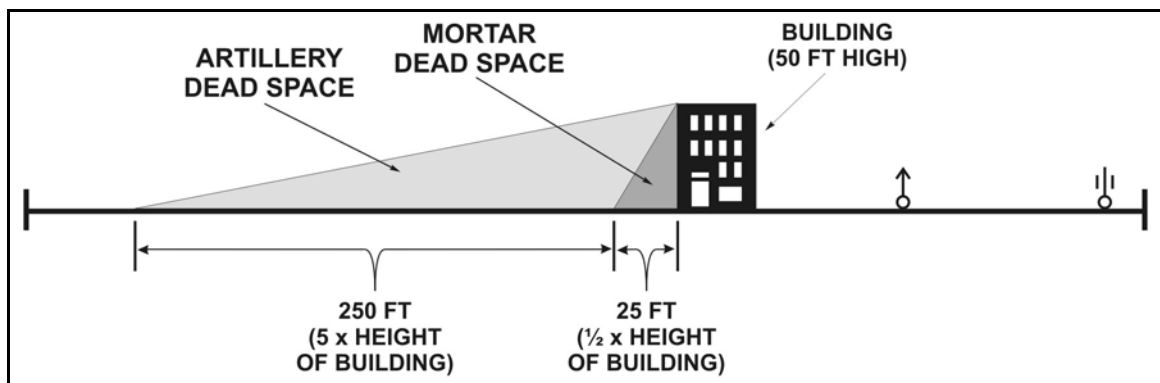


Figure 7-7. Dead space.

### 7-16. FIELD ARTILLERY

Appropriate fire support coordination measures are essential because fighting in urban areas results in opposing forces fighting in close combat. When planning for fire support in an urban area, the following should be considered.

- a. Target acquisition may be more difficult because of the increased cover and concealment afforded by the terrain. Ground observation is limited in urban areas.

Adjusting fires is difficult since buildings block the view of adjusting rounds; therefore, the lateral method of adjustment may be most useful.

b. Initial rounds are adjusted laterally until a round impacts on the street perpendicular to the FEBA. Airburst rounds are best for this adjustment. The adjustments must be made by sound. When rounds impact on the perpendicular street, they are adjusted for range. When the range is correct, a lateral shift is made onto the target, and the gunner fires for effect.

c. Special considerations apply to shell and fuze combinations when buildings limit effects of munitions:

- Careful use of variable time (VT) is required to avoid premature arming.
- Indirect fires may create unwanted rubble and collateral damage.
- The close proximity of enemy and friendly troops requires careful coordination.
- WP may create unwanted fires and smoke.
- Fuze delay should be used to penetrate fortifications.
- Illumination rounds can be effective; however, friendly positions should remain in shadows, and enemy positions should be highlighted. Tall buildings may mask the effects of illumination rounds.
- VT, time, and improved conventional munitions (ICM) are effective for clearing enemy positions, observers, and antennas from rooftops.
- Swirling winds may degrade smoke operations.
- Scatterable mines (SCATMINES) may be used to impede enemy movements. SCATMINE effectiveness is reduced when delivered on a hard surface.

d. Target acquisition is difficult in urban terrain because the enemy has many covered and concealed positions and movement lanes. The enemy may be on rooftops, in buildings, and in sewer and subway systems. Aerial observers are extremely valuable for targeting because they can see deep to detect movements, positions on rooftops, and fortifications. Targets should be planned on rooftops to clear away enemy FOs as well as communications and radar equipment. Targets should also be planned on major roads, at road intersections, and on known or likely enemy positions. Consider employing artillery in the direct fire mode to destroy fortifications, especially when assaulting well-prepared enemy positions. Also, restrictive fire support coordination measures, such as a restricted fire area or no-fire area, may be needed to protect civilians and critical installations.

e. Self-propelled 155-mm howitzers are effective in neutralizing concrete targets with direct fire. Concrete-piercing 155-mm rounds can penetrate 36 inches of concrete at ranges up to 2,200 meters. The mounted .50-caliber machine gun can also be used as direct fire support. Infantry must closely protect howitzers when used in the direct fire mode since they do not have any significant protection for their crews.

f. Forward observers must be able to determine where and how large the dead spaces are. This area is a safe haven for the enemy because he is protected from indirect fires. For low-angle artillery, the dead space is about five times the height of the building. For high-angle artillery, the dead space is about one half the height of the building (Figure 7-7, page 7-19.)

g. Aerial observers are effective for seeing behind buildings immediately to the front of friendly forces. They are extremely helpful when using the ladder method of adjustment because they may actually see the adjusting rounds impact behind buildings.

Aerial observers can also relay calls for fire when communications are degraded due to power lines or masking by buildings.

h. Radar can locate many artillery and mortar targets in an urban environment because of the high percentage of high-angle fires. If radar is sited too close behind tall buildings, it loses some effectiveness.

i. The use of airburst fires is an effective means of clearing snipers from rooftops.

### 7-17. MORTARS

Mortars are well suited for combat in urban areas because of their high rate of fire, steep angle of fall, and short minimum range. (See chapter 9, paragraph 9-16, for additional information.)

### 7-18. COMMUNICATIONS

One of the biggest challenges for a TF staff is to maintain communications with subordinate elements. Buildings and electrical power lines reduce the range of digital communications and FM radios. Remoting radio sets or placing antennas on rooftops can solve the range problem for CPs and trains. Company teams do not have the assets to ensure continuous communications, so the TF staff must plan for continual movement of TF assets to support company team operations.

a. **Wire.** Wire is a secure and effective means of communications in urban areas. Wires should be laid underground, overhead on existing poles, or through buildings to prevent vehicles from cutting them.

b. **Messengers and Visual Signals.** Messengers and visual signals can also be used in urban areas. Messengers must plan routes that avoid the enemy. Routes and time schedules should be varied to avoid establishing a pattern. Visual signals must be planned so they can be seen from the buildings.

c. **Sound.** Sound signals are normally not effective in urban areas due to the amount of surrounding noise.

d. **Existing Systems.** If existing civilian or military communications facilities can be captured intact, they can also be used by the task force. An operable civilian phone system, for instance, can provide a reliable, although nonsecure, means of communication. Use of news media channels in the immediate area of operations for other-than-emergency communications must be coordinated through the S1 or civil affairs officer.

### 7-19. WEAPONS EFFECTS

The characteristics and nature of combat in urban areas affect the results and employment of weapons. Leaders at all levels must consider the following factors in various combinations.

a. **Surfaces.** Hard, smooth, flat surfaces are characteristic of urban targets. Rounds rarely impact perpendicular to these flat surfaces but rather at some angle of obliquity. This reduces the effect of a round and increases the threat of ricochets.

b. **Ranges and Engagement Time.** Engagement times are short, and ranges are close in urban areas. About 90 percent of all targets are located 50 meters or less from the identifying soldier. Minimum arming ranges and troop safety from backblast or fragmentation effects must be considered.

c. **Depression and Elevation Limits.** Depression and elevation limits for some weapons create dead space. Tall buildings form deep canyons that are often safe from indirect fires. Some weapons can fire rounds to ricochet behind cover and inflict casualties. Target engagement from horizontal and vertical oblique angles demands superior marksmanship skills.

d. **Obscuration.** Smoke from burning buildings, dust from explosions, shadows from tall buildings, and the lack of light penetrating inner rooms combine to reduce visibility and increase a sense of isolation. Added to this is the masking of fires caused by rubble and manmade structures. Targets, even those at close range, tend to be indistinct.

e. **Confusion.** Urban fighting often becomes a confused melee with several small units attacking on converging axes. The risks from friendly fires, ricochets, and fratricide must be considered during planning. Control measures must be continually adjusted to reduce the risks. Soldiers and leaders must maintain a sense of situational understanding and clearly mark their progress IAW unit SOP to avoid fratricide.

f. **Buildings.** Both the shooter and target may be inside or outside buildings. They may be inside the same building or in separate buildings. The enclosed nature of combat in urban areas means the weapon's effect, such as muzzle blast or backblast and penetration from room to room, must be considered as well as the round's impact on the target. Usually, manmade structures must be attacked before enemy personnel inside are attacked. Weapons and demolitions may be chosen for employment based on their effects against masonry and concrete rather than against enemy personnel.

#### **Section IV. OFFENSIVE OPERATIONS**

Military references addressing "modern experiences in city combat" as far back as 1942 discuss shock units or special assault teams being used by attackers (and often defenders) with great success. These assault teams are characterized by the integration of combined arms and typically contain infantry with variable combinations of armor, artillery, or engineers. The following passage illustrates combined-arms operations conducted in an urban combat environment during World War II:

*The battalion plan of action was as follows: one platoon of Company "F," with a light machine gun section, would stage the initial diversionary attack. It would be supported by two tanks and two tank destroyers, who were instructed to shoot at all or any suspected targets. Observation posts had been manned on a slag pile to support the advance with 81-mm mortar fire...The platoon action was to be the first step...to reduce the town of Aachen.*

*...the remainder of our zone of action...would be cleared by Companies "F" and "G," who would execute a flanking attack, jumping off abreast of each other through the area secured by the Company "F" platoon...Preparatory fire by medium artillery was to be planned...Mortar observers would accompany each company...Tanks and tank destroyers were assigned to each company...*

LTC Darrel M. Daniel  
Commander, 2nd Bn, 26th Inf Regt  
October, 1944, Battle of Aachen

## 7-20. OFFENSIVE FRAMEWORK

Figure 7-8 depicts the urban operational framework as it applies to offensive operations and shows the tactical tasks of subordinate units. While the elements of the operational framework are not phases, tactical tasks may become phases at the battalion level and below, based on the factors of METT-TC. Properly planned and executed offensive operations involve all tactical tasks shown. They may be conducted simultaneously or sequentially, depending on the factors of METT-TC. During offensive operations, the TF commander's intent normally includes--

- Synchronizing precision fires, information operations, and nonlethal capabilities.
- Isolating decisive points.
- Using superior combat power to destroy HPTs.
- Using close combat, when necessary, against decisive points.
- Transitioning quickly to stability or support operations.

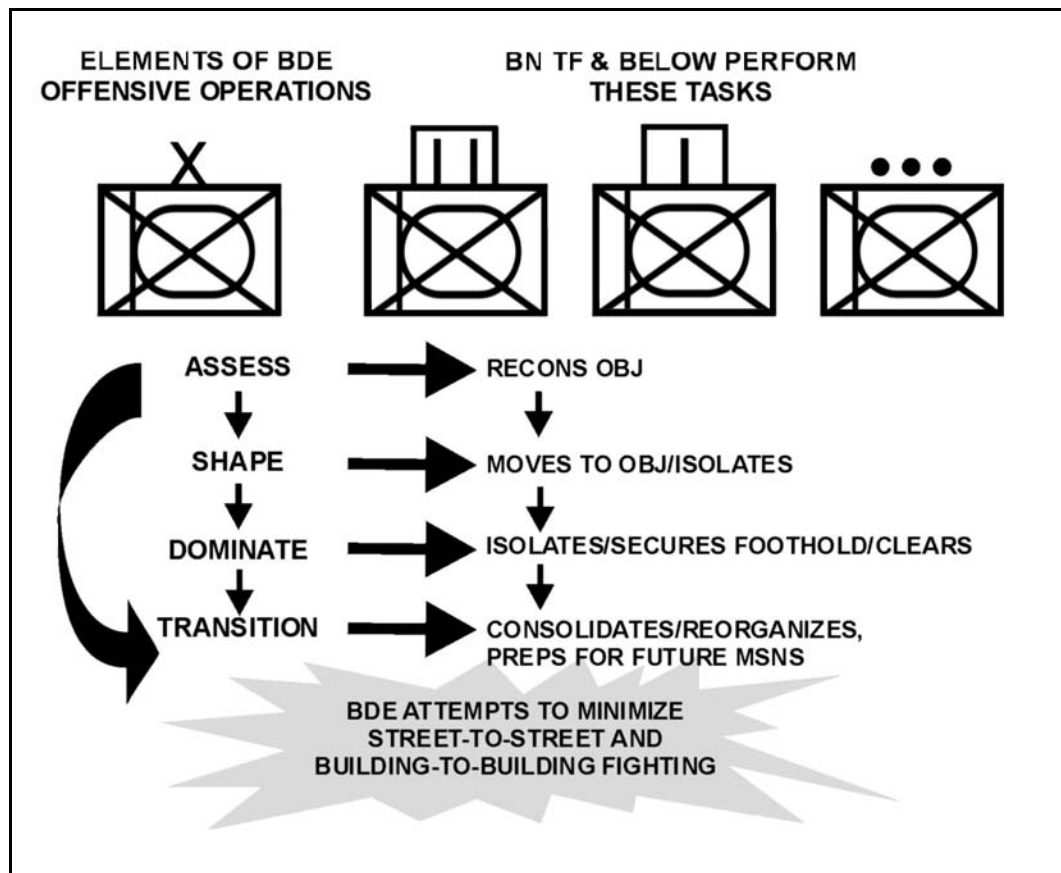


Figure 7-8. Offensive urban operational framework.

## 7-21. TYPES OF ATTACK DURING URBAN OFFENSIVE OPERATIONS

Offensive operations in an urban area are planned and implemented based on the factors of METT-TC. At the TF level, the offense takes the form of an attack.

a. **Attack under Hasty Conditions.** TFs conduct an attack after a successful defense or as part of a defense; as a result of a movement to contact, a meeting

engagement, or a chance contact during a movement; or in a situation where the unit has the opportunity to attack vulnerable enemy forces. The attack in an urban area differs because the close, complex nature of the terrain makes command, control, and communications, as well as massing fires to suppress the enemy, more difficult. In urban areas, incomplete information, intelligence, and concealment may require the maneuver unit to move through, rather than around, the friendly unit fixing the enemy in place. Control and coordination become important to reduce congestion at the edges of the urban area.

b. **Attack under Deliberate conditions.** An attack during deliberate operation is a fully synchronized operation that employs all available assets against the enemy's defense (IAW with the ROE). It is characterized by detailed planning based on available information, thorough reconnaissance, preparation, and rehearsals. Given the nature of urban terrain, the attack of an urban area is similar to the techniques employed in assaulting a strongpoint. At the TF level, attack of an urban area usually involves the sequential execution of the following tactical tasks.

(1) **Reconnoiter the Objective.** This involves making a physical reconnaissance of the objective with TF assets and those of higher headquarters as the tactical situation permits. It also involves making a map reconnaissance of the objective and all the terrain that will affect the mission and an analysis of aerial imagery, photographs, or any other detailed information about the building(s) and other appropriate urban terrain. Additionally, any human intelligence collected by reconnaissance and surveillance units, such as the TF reconnaissance platoon, snipers, and so forth, should be considered during the planning process.

(2) **Move to the Objective.** This may involve moving through open terrain, urban terrain, or both. Movement should be made along covered and concealed routes and as rapidly as possible without sacrificing security. It can involve moving through buildings, down streets, in subsurface areas, or a combination of all three.

(3) **Isolate the Objective.** Isolation begins with the efforts of special operations force (SOF) units controlled by higher headquarters to influence enemy and civilian actions.

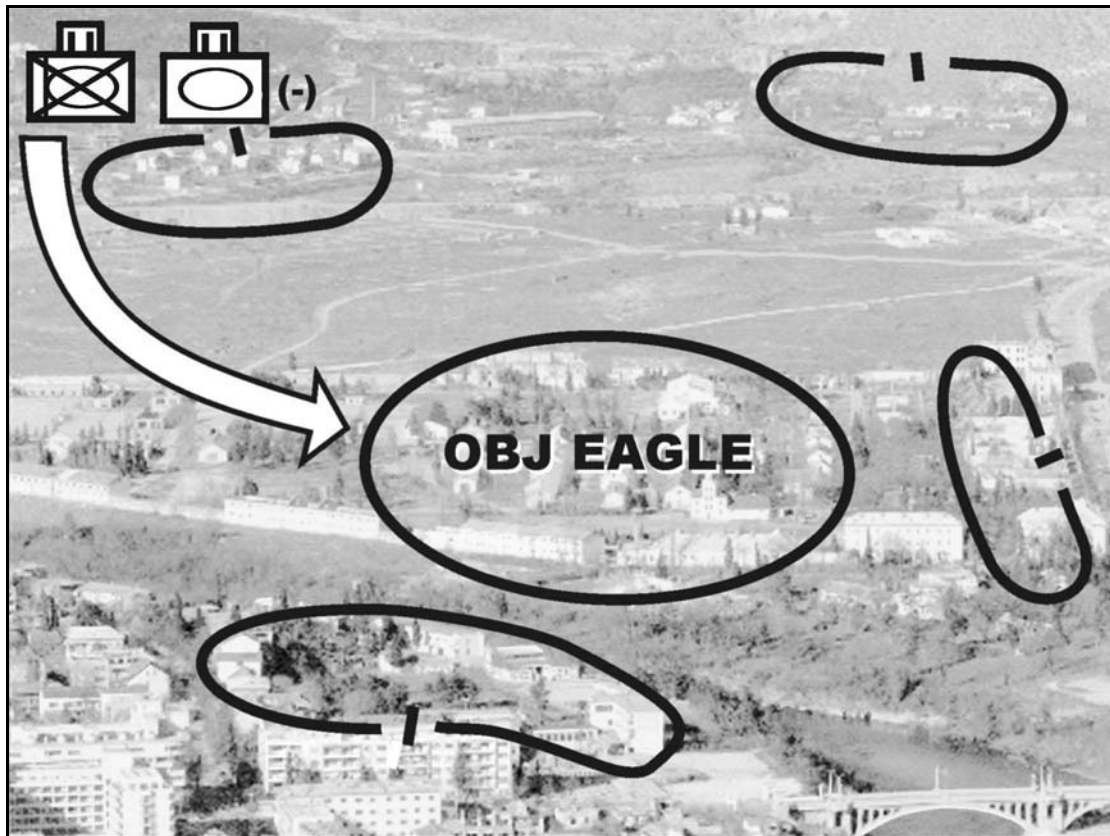
(a) The TF commander should consider using PSYOP teams, if available, to broadcast appropriate messages to the enemy and to deliver leaflets directing the civilian population to move to a designated safe area.

(b) In certain situations requiring precise fire, snipers can provide an excellent method of isolating key areas while simultaneously minimizing collateral damage and noncombatant casualties.

(c) Isolating the objective also involves seizing terrain that dominates the area so that the enemy cannot supply, reinforce, or withdraw its defenders. It also includes selecting terrain that provides the ability to place suppressive fire on the objective. TFs may be required to isolate an objective as part of the overall brigade operation or to do so independently (Figure 7-9). Depending on the tactical situation, company teams within the TF may have to isolate an objective by infiltration.

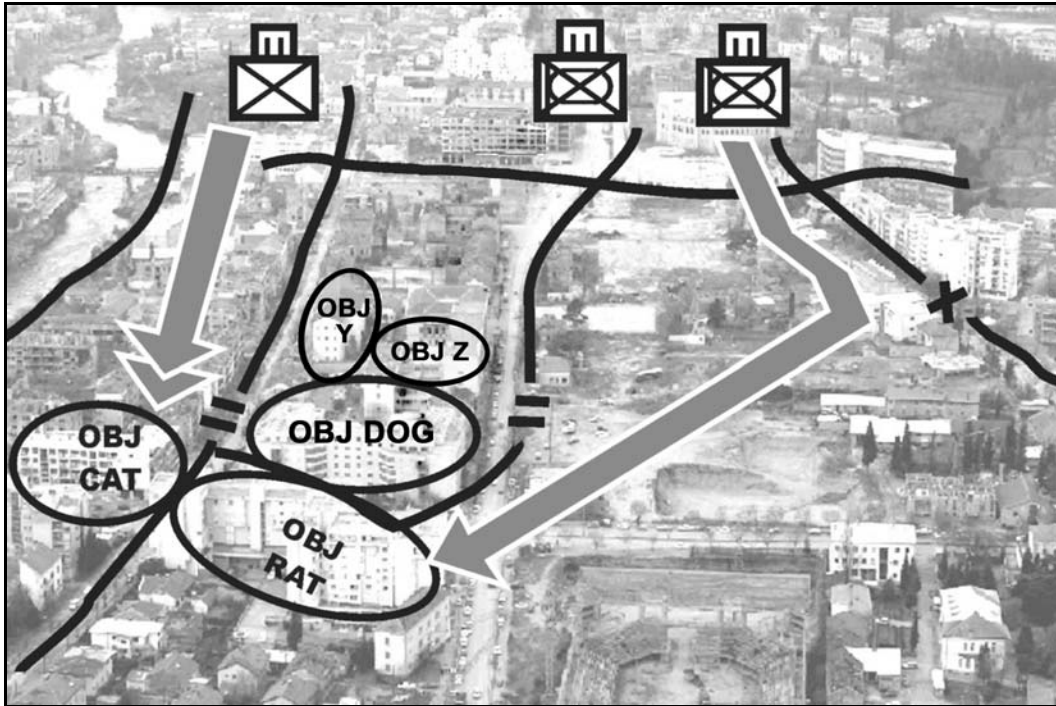
(d) Cordon and attack is a tactical task given to a unit to prevent enemy withdrawal from or reinforcement of a position. A cordon is a type of isolation. It implies seizing or controlling key terrain or mounted and dismounted avenues of approach. Figure 7-9, depicts an infantry-heavy brigade attacking to seize and clear OBJ EAGLE using the cordon and attack technique. The armor TF cordons OBJ EAGLE by occupying battle

positions; the infantry TF seizes OBJ Eagle. Skillful application of fires and other combat multipliers may also defeat the enemy and preclude close combat. In the example shown in Figure 7-9, the battle positions are oriented to place fires on the enemy leaving OBJ EAGLE and to prevent his withdrawal from the objective area. The factors of METT-TC determine the mission end state and how the battle positions are oriented. Additional direct fire control measures, such as target reference points, engagement areas, and indirect fire control measures, can focus fires and assist in canalizing the enemy into desired areas.



**Figure 7-9. Isolation of an urban area using the cordon technique.**

(4) **Secure a Foothold.** Securing a foothold involves seizing an intermediate objective that provides cover from enemy fire and a location for attacking troops to enter the urban area. The size of the foothold depends on the factors of METT-TC. For example, as one of the task force company teams attack to gain a foothold, it should be supported by suppressive fire and obscurants. In the example shown in Figure 7-10, page 7-26, the center TF conducts a supporting attack to seize OBJ DOG and the TF commander has determined that two intermediate objectives are necessary in order to seize OBJ DOG.



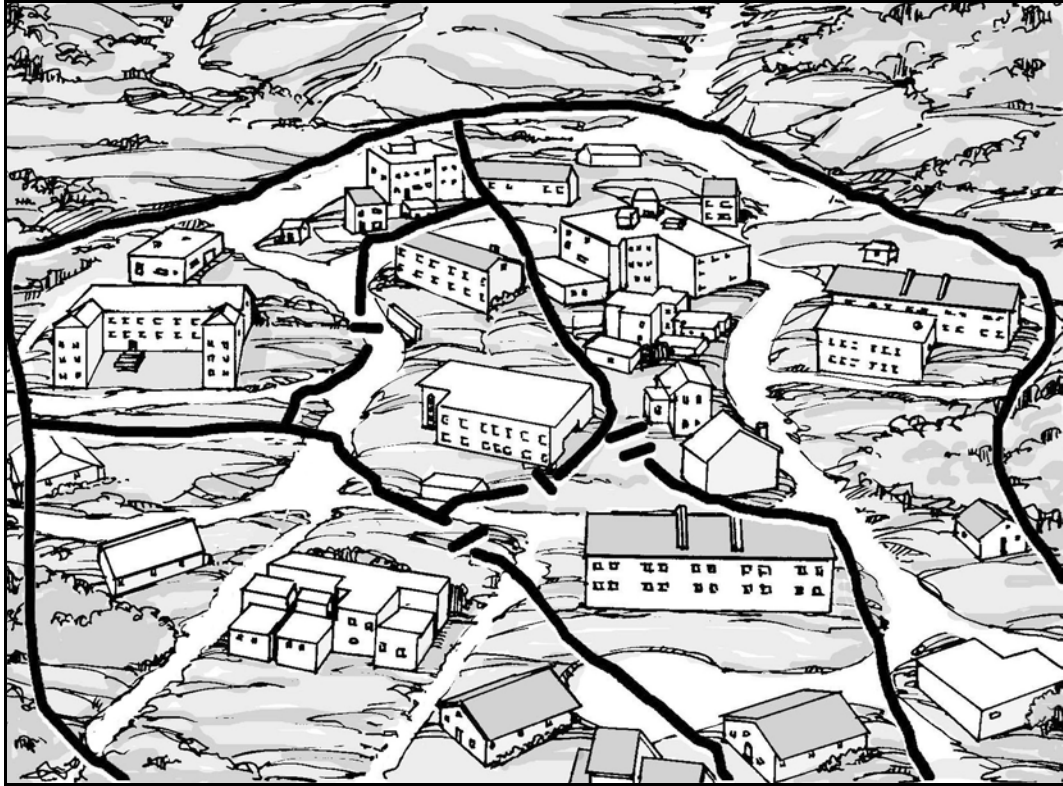
**Figure 7-10. Securing a foothold, task force attack.**

(5) **Clear the Objective.** The commander may decide to clear only those parts of the area necessary for the success of his mission if--

- An objective must be seized quickly.
- Enemy resistance is light or fragmented.
- The buildings in the area have large open areas between them. (In this case, the commander clears only those buildings along the approach to his objective or only those buildings necessary for security.)

The TF may have a mission to systematically clear an area of all enemy. Through detailed analysis, the TF commander may anticipate that he will be opposed by a strong, organized resistance or will be in areas having strongly constructed buildings close together. He may assign his company teams areas within the TF AO in order to conduct systematic clearing (Figure 7-11).





**Figure 7-11. Example of how to develop a systematic clearance within assigned areas.**

(6) *Consolidate or Reorganize and Prepare for Future Missions.* Consolidation occurs immediately after each action. Reorganization and preparation for future missions occurs after consolidation. Many of these actions occur simultaneously.

(a) Consolidation provides security, facilitates reorganization, and allows the TF to prepare for counterattack. Rapid consolidation after an engagement is extremely important in an urban environment.

(b) Reorganization actions (many occurring simultaneously) prepare the unit to continue the mission. The TF prepares to continue the attack or prepares for future missions, including the possible transition to stability and support operations.

## 7-22. TRANSITION

During transition, the TF continues to use all CS and CSS assets, consistent with the mission end state and ROE, to move from offensive operations to stability or support operations. The ultimate goal is to return the urban area to civilian control. During this step, the roles and uses of SOF, CS, and CSS units (civil affairs, PSYOP, medical, and military police) become more important with the requirements to maintain order and stabilize the urban area. These assets normally support the TF's transition efforts under brigade control. The TF staff, in coordination with the brigade staff, must prepare to transition from being a "supported" force to being the "supporting" force.

### 7-23. MOVEMENT TO CONTACT

Figure 7-12 depicts a movement to contact in an urban area using the search and attack technique. The TF uses this technique when its knowledge of the enemy is unclear and it must make contact. The TF normally employs this technique against a weak enemy force that is disorganized and incapable of massing strength, such as urban insurgents or gangs. The TF divides its portion of the AO into smaller areas and coordinates the movement of company teams. It can either assign sectors to specific company teams or control their movement by sequential or alternate bounds within the TF sector. During a mission of this type, the urban environment makes finding, fixing, and finishing the enemy difficult. For example, movement of units may become canalized due to streets and urban “canyons” created by tall buildings. The application of firepower may become highly restricted based on the ROE. The use of HUMINT in this type of action becomes increasingly more important and can be of great assistance during the “find” portion of the mission. This mission requires close coordination between infantry and armored vehicles as they move through and search the urban area.

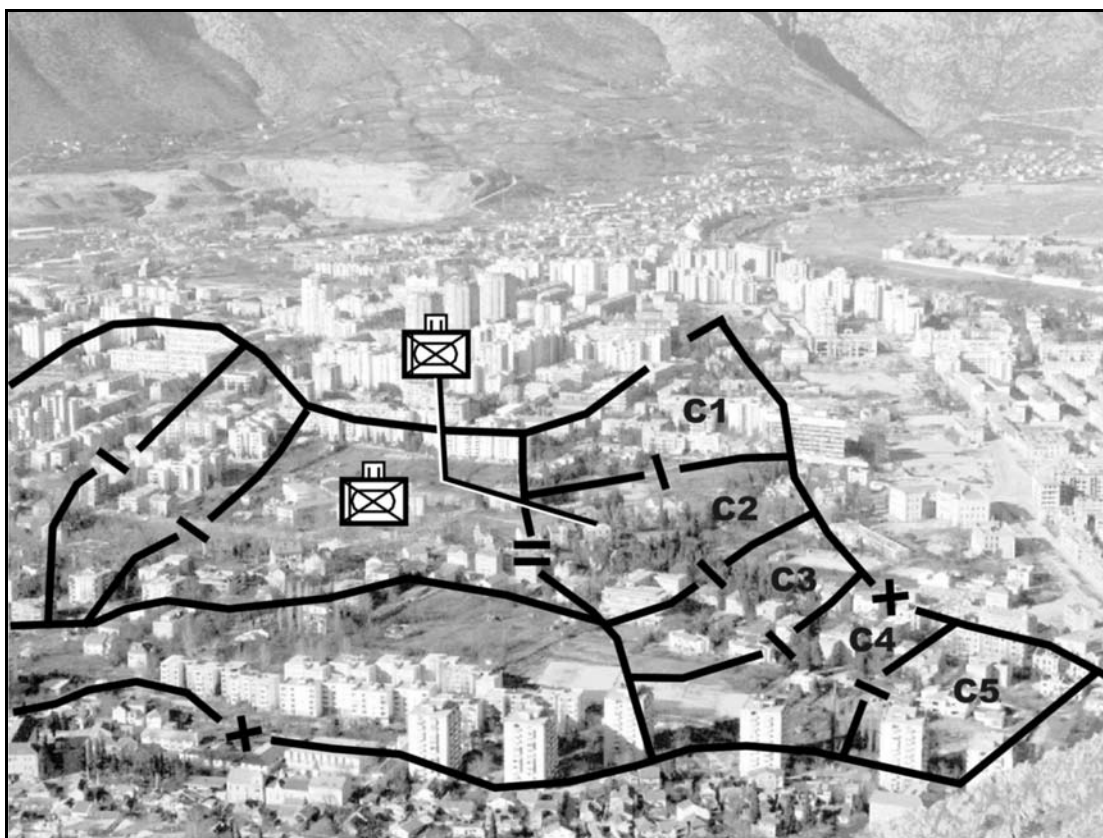


Figure 7-12. Graphical control measures to facilitate search and attack technique.

### 7-24. ATTACK OF A VILLAGE

The TF may have to conduct an attack of a village that is partially or completely surrounded by open terrain. (Figure 7-13 depicts a TF conducting such an attack.) After considering the factors of METT-TC, the TF performs the tactical tasks (specifically, reconnoiter the objective, move to the objective, isolate the objective, secure a foothold, clear the objective, and consolidate, reorganize, and prepare for future missions).

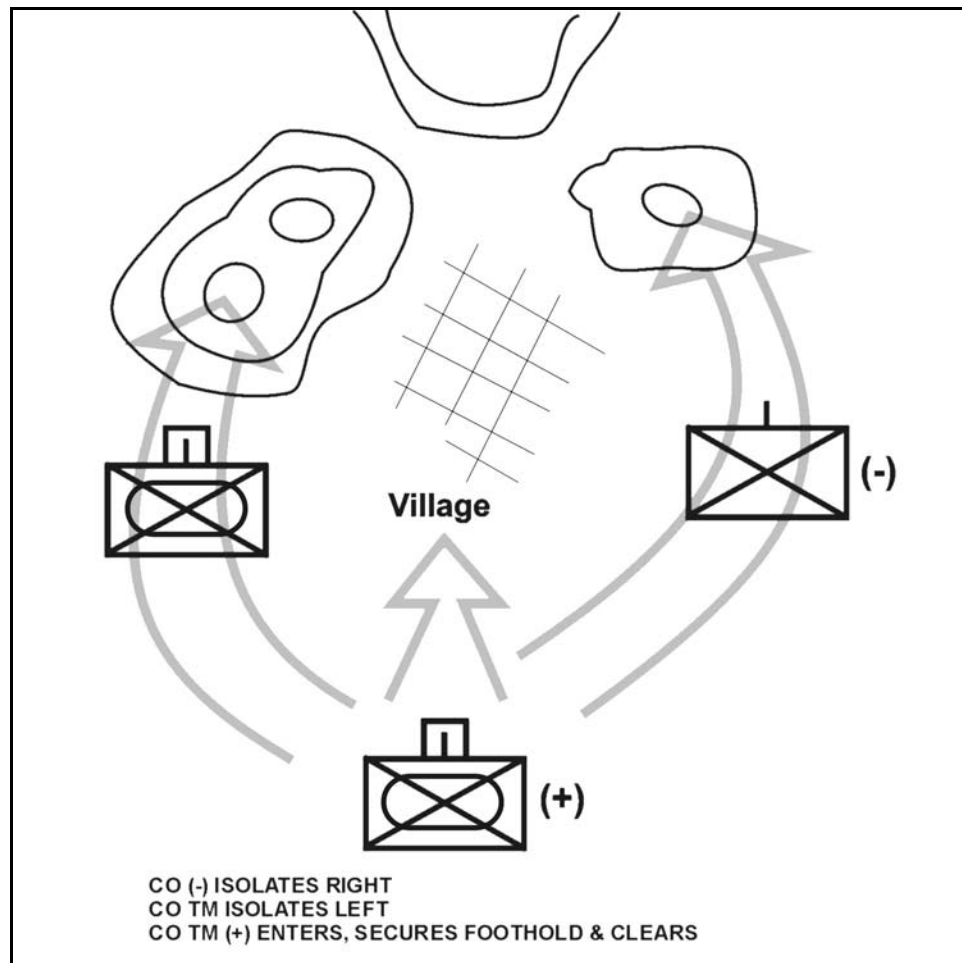


Figure 7-13. Attack of a village.

### 7-25. NODAL ATTACK

The TF may receive the mission to seize a key node (or nodes) as part of a brigade operation. In certain situations, the TF may have to seize nodes independently. Nodal attacks are characterized by rapid attacks followed by defensive operations. The enemy situation must permit the attacking force to divide its forces and seize key nodes. Multiple attacks (as depicted in Figure 7-14, page 7-30, and Figure 7-15, page 7-31) require precise maneuver and supporting fires. The TF may receive a nodal attack mission before an anticipated stability or support operation or when isolation of an urban area is required so other units can conduct offensive operations inside the urban area. Figure 7-14, page 7-30, depicts a brigade conducting multiple nodal attacks. Figure 7-15, page 7-31, depicts a TF executing a nodal attack. Nodal attacks are used to deny the

enemy key infrastructure. They may require a designated rapid response element (or elements) in reserve in the event that enemy forces mass and quickly overwhelm an attacking TF. Normally, the reserve is planned at brigade level, but TFs executing a nodal attack independently must plan for a designated rapid response reserve element. The duration of this attack should not exceed the TF's self-sustainment capability.

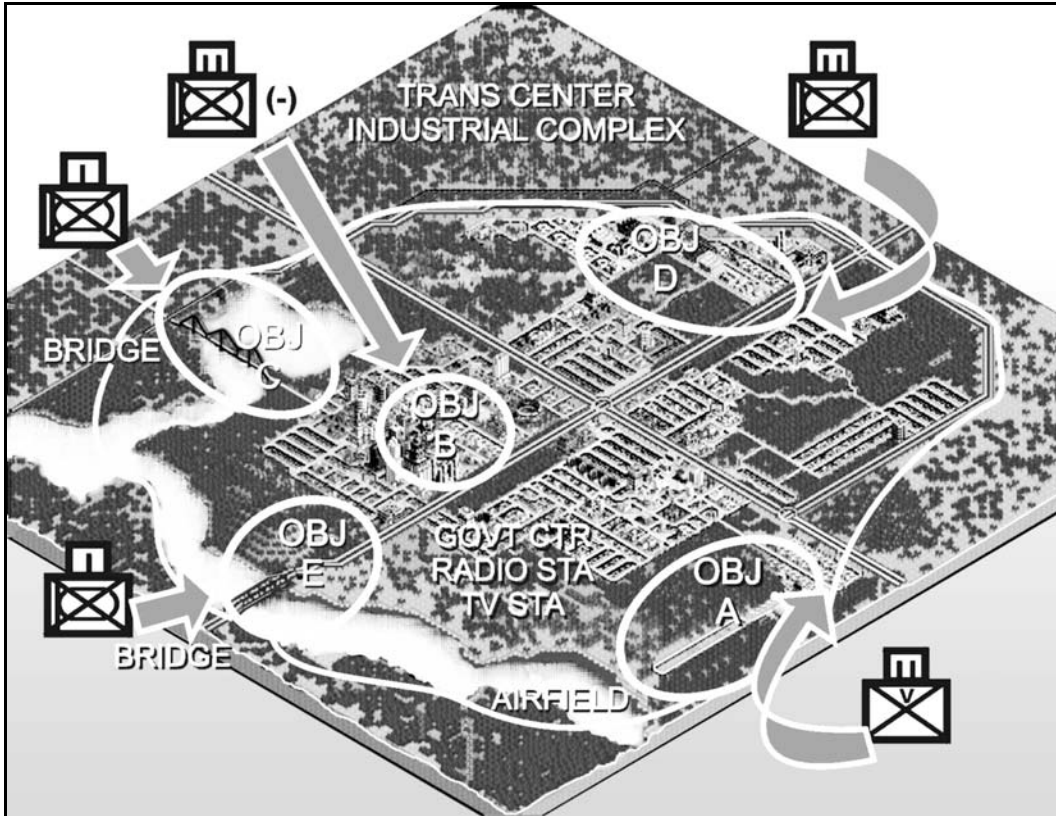
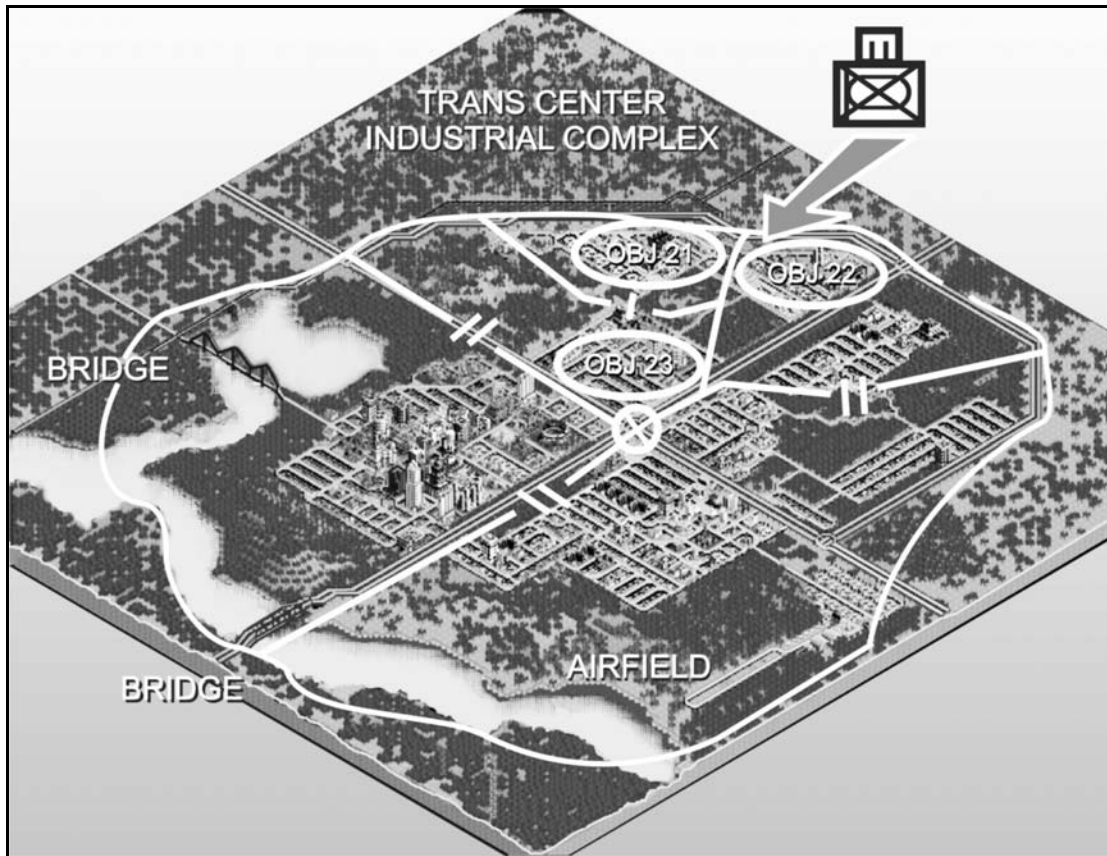


Figure 7-14. Brigade scheme of maneuver, nodal attack.



**Figure 7-15. Task force nodal attack.**

### **Section V. DEFENSIVE OPERATIONS**

An area defense concentrates on denying an enemy force access to designated terrain for a specific time and is the type most often used for defending an urban area. The mobile defense concentrates on the destruction or defeat of the enemy through a decisive counterattack. A division or corps most frequently conducts a mobile defense, but the brigade is also capable of conducting a mobile defense. Mechanized and armor forces participate in mobile defenses as an element in the fixing force conducting a delay or area defense or as an element of the striking force conducting offensive operations. In an urban area, the defender must take advantage of the abundant cover and concealment. He must also consider restrictions to the attacker's ability to maneuver and observe. By using the terrain and fighting from well-prepared and mutually supporting positions, a defending force can inflict heavy losses upon, delay, block, or fix a much larger attacking force.

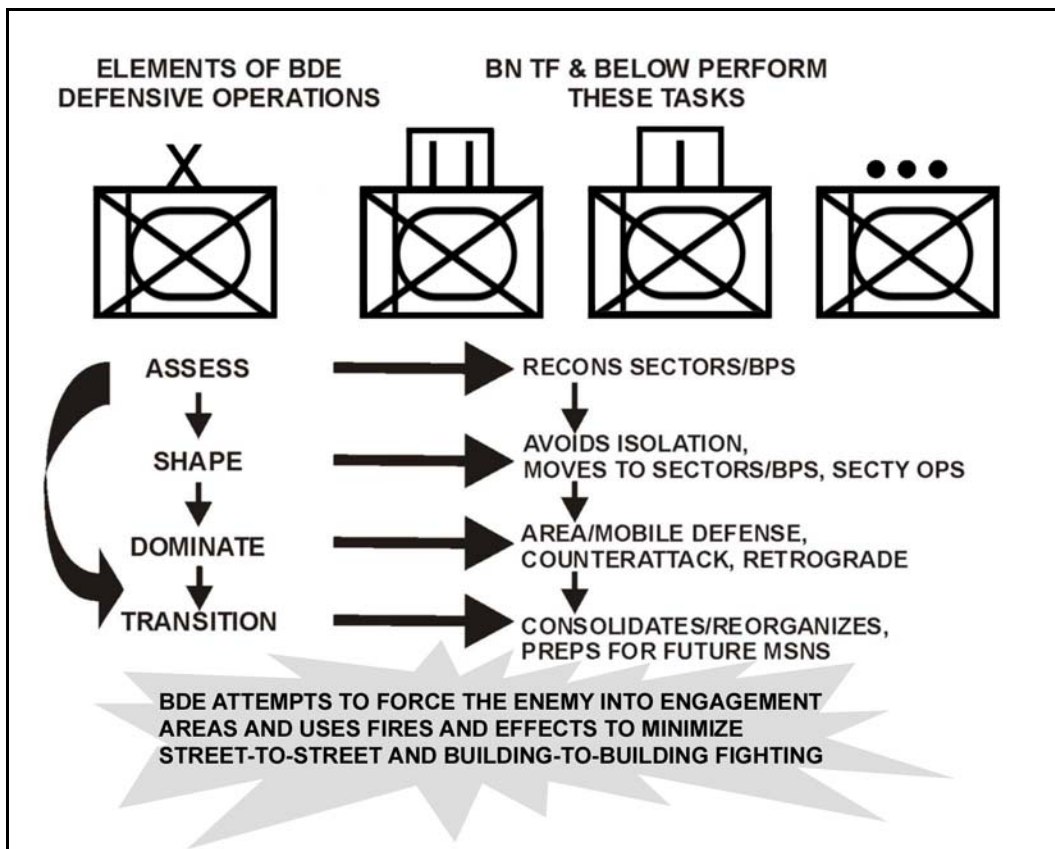
#### **7-26. DEFENSIVE FRAMEWORK**

Normally, the TF conducts defensive operations as part of a brigade. The brigade can conduct the full range of defensive operations within a single urban area or in an AO that contains several small towns and cities using the elements of the urban operational framework shown in Figure 7-16, page 7-32. The brigade avoids being isolated through security operations. It assigns defensive missions to subordinate TFs in order to achieve the commander's intent and desired end state. Well-planned and executed defensive

operations have four elements: assess, shape, dominate, and transition. During defensive operations, the brigade commander seeks to--

- Avoid being isolated by the enemy.
- Defend key and decisive terrain, institutions, or infrastructure.
- Use offensive fire and maneuver to retain the initiative.

TFs conduct defensive operations by conducting counterreconnaissance missions and patrols (avoiding isolation); assigning battle positions or sectors to company teams (defending); and consolidating or reorganizing and preparing for follow-on missions (transitioning).



**Figure 7-16. Defensive urban operational framework.**

### 7-27. DEFENSIVE PLANNING

TFs defending in urban areas must prepare their positions for all-round defense. Subordinate units must employ aggressive security operations that include surveillance of surface and subsurface approaches. TFs must constantly patrol and use OPs and sensors to maintain effective security. They must take special measures to control enemy combatants who have intermixed with the local population and civilian personnel who may support the enemy.

a. Defensive fire support in urban operations must take advantage of the impact of indirect fires on the enemy before he enters the protection of the urban area. Fire support officers at all levels must coordinate and rehearse contingencies that are inherent to nonlinear fire support coordination measures and clearance of fires. The fire support

officer also plans and coordinates nonlethal capabilities for the TF. Civil affairs and PSYOP assets should be coordinated with the appropriate command and control warfare or information operations headquarters.

b. In planning a defense in an urban area, the TF staff must identify the following:

- Positions and areas that must be controlled to prevent enemy infiltration.
- Sufficient covered and concealed routes for movement and repositioning of forces.
- Structures and areas that dominate the urban area.
- Areas, such as parks and broad streets, that provide fields of fire for tanks and antiarmor weapons.
- Areas to position artillery assets.
- C2 locations.
- Protected areas for CSS activities.
- Suitable structures that are defensible and provide protection for defenders.
- Contingency plans in the event that the TF must conduct breakout operations.
- Plans for rapid reinforcement.

#### 7-28. INTEGRATING THE URBAN AREA INTO THE DEFENSE

The TF may integrate villages and small towns into the overall defense, based on higher headquarters' constraints and applicable ROE (Figure 7-17). A defense in an urban area, or one that incorporates urban areas, normally follows the same sequence of actions and is governed by the principles contained in Chapter 6. When defending on predominately urban areas, the TF commander must consider that the terrain is more restrictive due to buildings that are normally close together. This usually requires a higher density of troops and smaller company team sectors or battle positions than in open terrain.

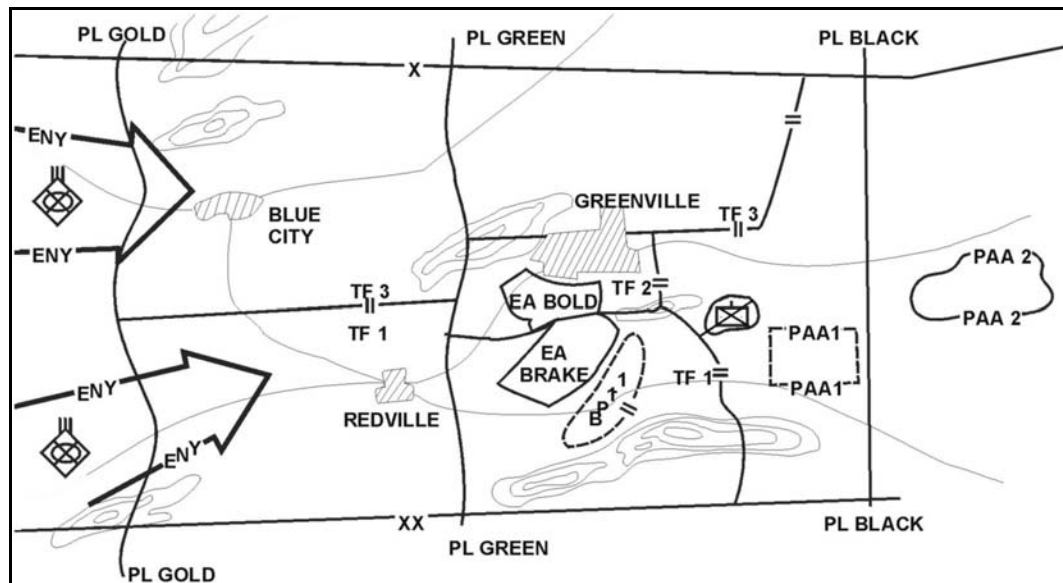
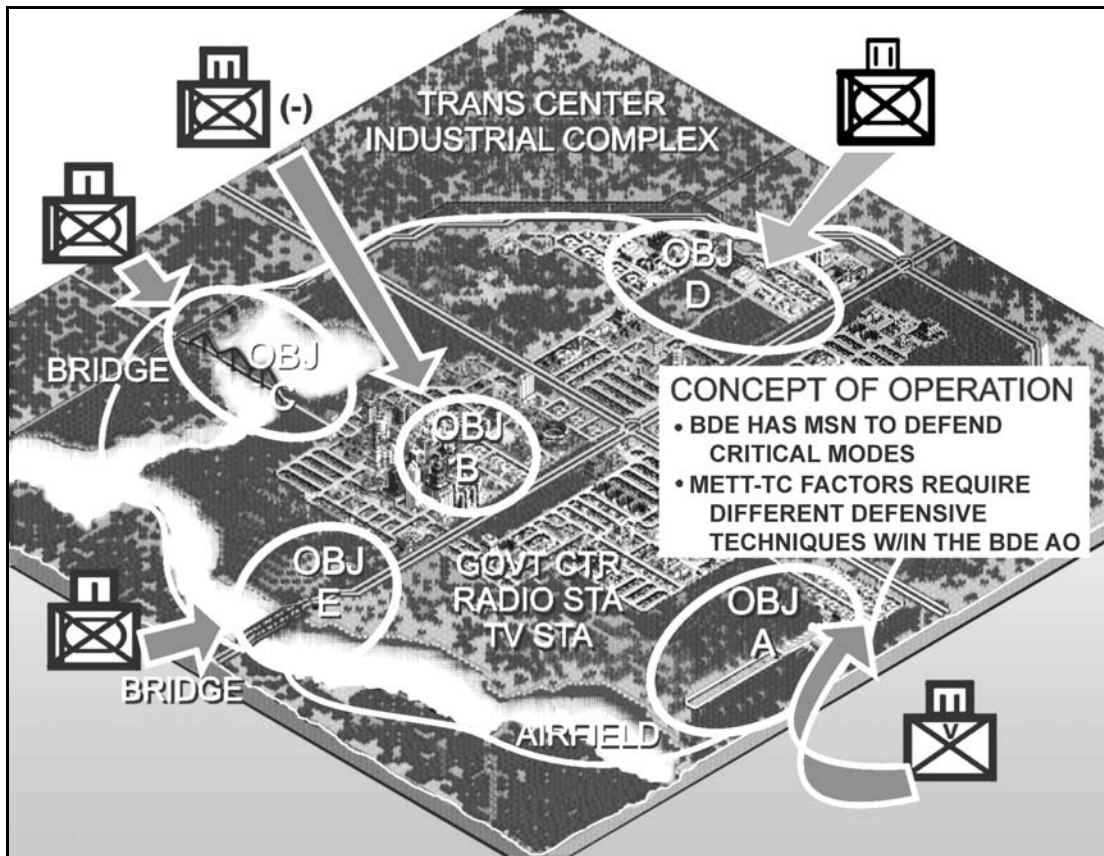


Figure 7-17. Integrating urban areas into a defense.

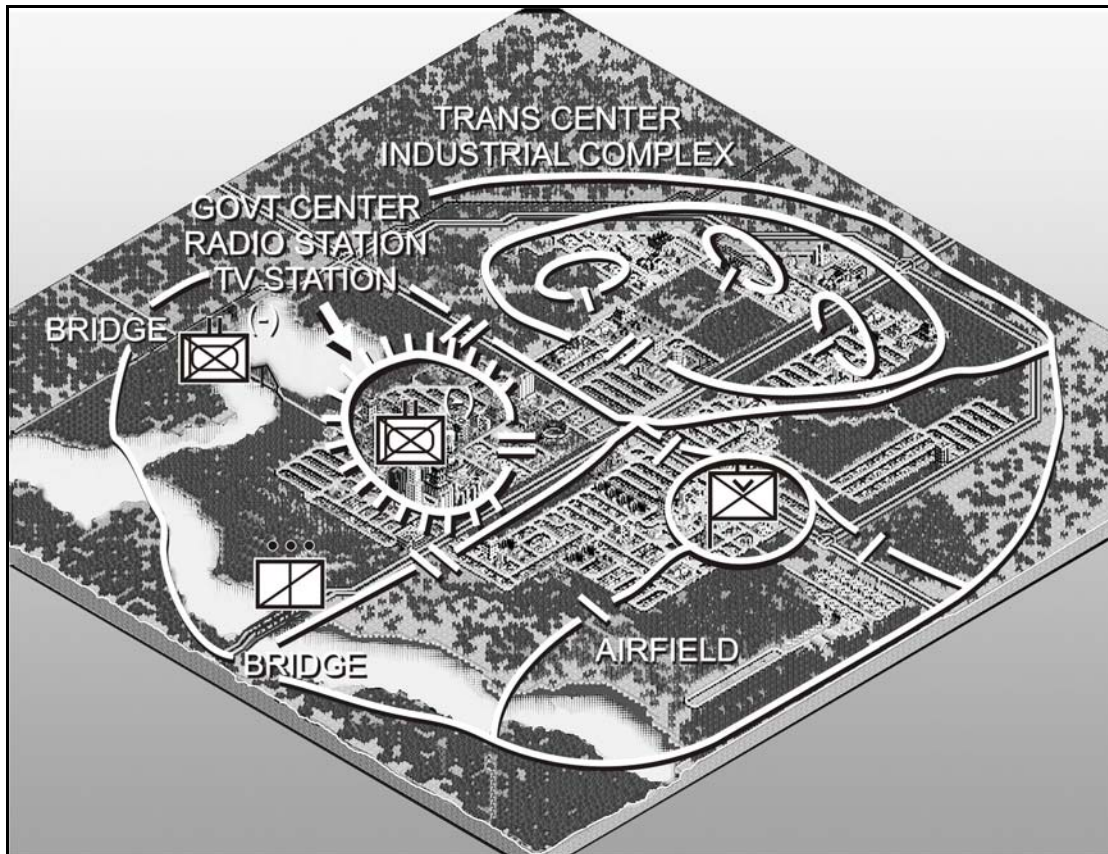
**7-29. NODAL DEFENSE**

Figure 7-18 depicts a transitional situation where the TF moves from an offensive to a defensive operation. The brigade mission may contain factors that require varying defensive techniques by the subordinate TFs under the brigade's control. Figure 7-19 depicts a nodal defense where TFs employ different defensive techniques in order to achieve the brigade commander's desired end state. The brigade commander's intent is to safeguard the key nodes seized during the offensive operation in order to return the infrastructure of this particular urban area back to civilian control eventually. Each battalion employs a different defensive technique: strongpoint, perimeter, and battle position.



**Figure 7-18. Nodal defense, transitional situation.**





**Figure 7-19. Nodal defense, different defensive techniques.**

a. **Task Organization.** Company teams may have to be task-organized to conduct the specific missions assigned by the TF commander in a nodal defense.

b. **Symmetrical and Asymmetrical Threats.** The TF is likely to respond to both symmetrical and asymmetrical threats within the area of operations. The defensive techniques chosen by subordinate company teams should allow them to respond to the specific threats in their respective AOs, battle positions, or sectors.

c. **Boundary Changes.** Again, based on the TF commander's intent and the defensive scheme of maneuver, boundary changes may be required in order to give company teams more or less maneuver space.

d. **ROE Modification.** The ROE may require modification based on the type of mission to be conducted. The ROE may become more or less restrictive based on METT-TC factors. Commanders and leaders must ensure that the ROE are clearly stated and widely disseminated at the beginning and conclusion of each day.

**NOTE:** The digital force has the potential to provide accurate enemy information that can enhance and facilitate targeting and obstacle placement. JSTARS, Guardrail, unmanned aerial vehicles (if present), and other reconnaissance assets can significantly improve the enemy targeting capability of the unit.

**7-30. DELAY**

The purpose of a delay is to slow the enemy, cause enemy casualties, and stop the enemy (where possible) without becoming decisively engaged or bypassed. The delay can be oriented either on the enemy or on specified terrain such as a key building or manufacturing complex.

a. **Ambushes and Battle Positions.** The TF conducts a delay in an urban area from a succession of ambushes and battle positions (Figure 7-20). The width of the TF AO depends on the amount of force available to control the area, the nature of the buildings and obstacles along the street, and the length of time that the enemy must be delayed.

(1) **Ambushes.** The TF plans ambushes on overwatching obstacles. Ambushes are closely coordinated but executed at the lowest levels. The deployment of the TF is realigned at important cross-streets. The TF can combine ambushes with limited objective attacks on the enemy's flanks, employing tanks and BFVs along with dismounted infantry. These are usually effective in the edge of open spaces (parks, wide streets, and so on).

(2) **Battle Positions.** The TF should place battle positions where heavy weapons, such as tanks, BFVs, antiarmor weapons, and machine guns, have the best fields of fire. Such locations are normally found at major street intersections, in parks, and at the edge of open residential areas. The TF should prepare battle positions carefully and deliberately, reinforce them with obstacles and demolished buildings, and support them using artillery and mortars. The TF should position BPs to inflict maximum casualties on the enemy and cause him to deploy for an attack.

b. **Two Delaying Echelons.** The TF is most effective when deployed in two delaying echelons which alternate between conducting ambushes and fighting from battle positions. As the enemy threatens to overrun a battle position, the company team disengages and delays back toward the next battle position. As the company team passes through the company team to the rear, it establishes another battle position. The TF uses smoke and demolitions to aid in the disengagement. Security elements on the flank can help prevent the enemy from out-flanking the delaying force. A small reserve can react to unexpected enemy action and conduct continued attacks on the enemy's flank.

c. **Engineers.** The engineer effort should be centralized at first to support the preparation of battle positions, then decentralized to support the force committed to ambush.

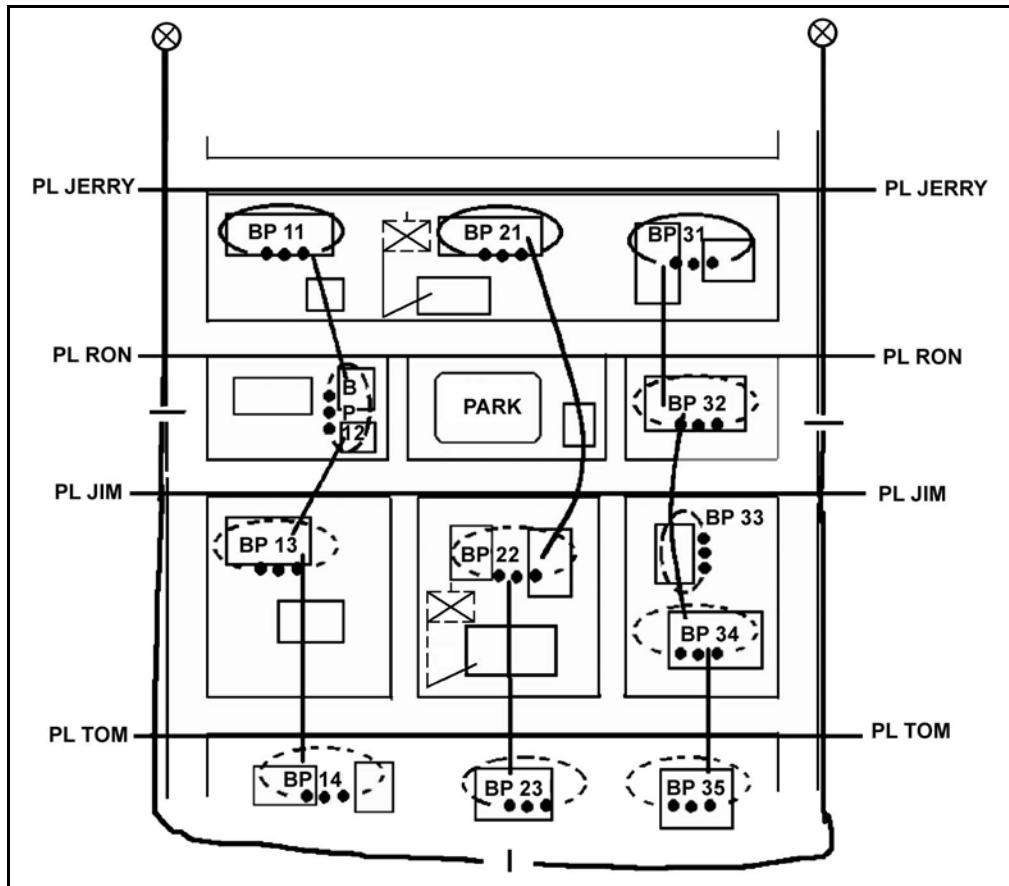


Figure 7-20. Task force delay in an urban area.

---

## CHAPTER 8

# STABILITY OPERATIONS AND SUPPORT OPERATIONS

*This chapter discusses both stability and support operations at the battalion task force level, defines both operations, and provides planning considerations. US forces are employed in these operations outside the US and US territories to promote and protect US national interests by influencing political, civil, and military environments and by disrupting specific illegal activities. Army forces must remain versatile and have the flexibility to transition from the primary mission of close, personal, and brutal fighting of traditional combat to nontraditional stability operations. The TF normally performs these types of operations as part of a larger, multinational, or unified team but could be required to work independently.*

*Army forces are highly suited for these types of operations because they are trained, equipped, and organized to control land, populations, and situations for extended periods of time. The depth and breadth of Army abilities provide the combatant commander of a unified command with vital options to meet theater operational requirements. These operations enhance theater engagement and promote regional stability.*

### Section I. STABILITY OPERATIONS

Stability operations promote and protect US national interest by influencing the threat, political, and information dimensions of the operational environment through a combination of peacetime developmental, cooperative activities, and coercive actions in response to crises. (FM 3-0) Army force presence promotes a secure environment in which diplomatic and economic programs designed to eliminate root causes of instability may flourish. Presence can take the form of forward basing, forward deploying, or pre-positioning assets in an AO. Army forces have the ability to establish and maintain a credible presence as long as necessary to achieve the desired results. Army force presence as part of a combatant commander's theater engagement plan (TEP) often keeps situations from escalating into war.

#### 8-1. PURPOSE

The overarching purpose of stability operations is to promote and sustain regional and global stability. These operations may complement and reinforce offensive, defensive, and support operations. Army forces conduct stability operations in crisis situations and before, during, and after offensive, defensive, and support operations. In a crisis situation, a stability operation can deter conflict or prevent escalation. During hostilities, it can help keep armed conflict from spreading and assist and encourage committed partners. Following hostilities, a stability operation can provide a secure environment in which civil authorities can work to regain control. Demonstrating the credible ability to conduct offensive and defensive operations underlies successful stability operations.

a. Stability operations are inherently complex and place greater demands at the small-unit level. Junior leaders are required to develop engagement skills while

maintaining warfighting skills. Capable, trained, disciplined, and high-quality leaders, soldiers, and teams are especially critical to success. Soldiers and units at every level must be flexible and adaptive. Stability operations often require the mental and physical agility to shift from noncombat to combat operations and back again.

b. Stability operations demonstrate American resolve through the commitment of time, resources, and forces to establish and reinforce diplomatic and military ties. Military forces conduct stability operations to accomplish one or more of the following activities:

- Protect national interests.
- Promote peace and deter aggression.
- Satisfy treaty obligations or enforce agreements and policies.
- Reassure allies, friendly governments, and agencies.
- Encourage a weak or faltering government.
- Maintain or restore order.
- Protect life and property.
- Demonstrate resolve.
- Prevent, deter, or respond to terrorism.
- Reduce the threat of conventional arms and WMD to regional security.
- Promote freedom from oppression, subversion, lawlessness, and insurgency.
- Promote sustainable and responsive institutions.

c. Stability operations may include both developmental and coercive actions. Developmental actions enhance a host nation government's willingness and ability to care for its people. Coercive actions apply carefully prescribed limited force or the threat of force to change the environment of the AO. For example, rapidly responding to a small-scale contingency operation can diffuse a crisis situation and restore regional stability.

d. Stability operations complement and are complemented by offensive, defensive, and support operations. Stability operations help restore law and order during support operations in unstable areas. Similarly, offensive and defensive operations may be necessary to defeat adversaries intent on preventing the success of a stability operation. The ability of Army forces to stabilize a crisis is related to its ability to attack and defend. For example, shows of force often precede offensive and defensive operations in attempts to deter aggression and provide opportunities for diplomatic and economic solutions.

e. Stability operations vary by type and are further differentiated by the specific factors of METT-TC. The TF performs many familiar core tactical missions and tasks during stability operations. The purposes of operations, the special constraints on commanders, and the unique missions and tasks, however, differentiate stability operations from other operations.

f. Ideally, the TF receives advance notice of stability operation missions and has time to modify its METL and complete a preparatory training program before deploying. In other cases, the TF may deploy and assume stability operation responsibilities on short notice. In those cases, the TF relies on its training in the fundamental tasks (such as command and control, patrolling, reporting, establishing OPs, and maintaining unit security) and trains to specific mission tasks during the operation.

g. In stability operations, commanders must emphasize cooperating and communicating with joint headquarters, multinational units, civilian authorities, and

nongovernmental agencies. Additionally, close association with the population of the area of operations typifies many stability operations. Some considerations that assist the TF in developing concepts and schemes for executing stability operations include--

- Leveraging interagency, joint, and multi-national cooperation.
- Enhancing the capabilities and legitimacy of the host nation.
- Understanding the potential for unintended consequences of the TF's actions.
- Displaying the capability to use force in a non-threatening manner.
- Acting decisively to prevent escalation.
- Applying force selectively and discriminately.

## **8-2. TYPES OF STABILITY OPERATIONS**

Stability operations typically fall into ten broad types that are neither discrete nor mutually exclusive. For example, a force engaged in a peace operation may also find itself conducting arms control or a show of force to set the conditions for achieving an end state. This section provides an introductory discussion of stability operations; for more detailed information, refer to FM 3-0 and FM 3-07. Types of stability operations are as follows:

- Peace operations:
  - Foreign internal defense.
  - Security assistance.
  - Humanitarian and civic assistance.
  - Support to insurgencies.
  - Support to counterdrug operations.
  - Combating terrorism.
  - Noncombatant evacuation operations.
  - Arms control.
  - Show of force.

## **8-3. PEACE OPERATIONS**

Peace operations (POs) are the most common stability operation the TF executes because they support strategic and policy objectives and the diplomatic activities that implement them. POs include peacekeeping operations (PKOs), peace enforcement operations (PEOs), and operations in support of diplomatic efforts. Although the US normally participates in POs under the sponsorship of the United Nations (UN) or another multinational organization, it reserves the right to conduct POs unilaterally. Optimally, forces should not transition from one PO role to another unless there is a change of mandate or a political decision with appropriate adjustments to force structure, ROE, and other aspects of the mission. Nevertheless, just as in other operations, it is crucial that commanders and staffs continually assess the mission. In POs, this translates into planning for possible or likely transitions. Examples include transitioning from a US unilateral operation or multinational coalition to a UN-led coalition, from combat to noncombat operations, or from military to civilian control.

a. **Peacekeeping.** PKOs are military operations that are undertaken with the consent of all major parties to a dispute and designed to monitor and facilitate implementation of agreements (such as a ceasefire or truce) and to support diplomatic efforts to reach a

long-term political settlement (FM 3-07). Before PKOs begin, a credible truce or ceasefire is in effect, and the belligerent parties consent to the operation.

(1) In peacekeeping operations, the TF must use all its capabilities short of coercive force to gain and maintain the initiative. The TF may be assigned a variety of missions designed to monitor peace and stability and to improve the humanitarian environment. The following are examples of PKO missions conducted by a TF:

- Deter violent acts through the physical presence of the PKO force at critical locations.
- Conduct liaison with disputing parties.
- Verify the storage or destruction of military equipment.
- Verify disarmament and demobilization of selected disputing forces.
- Negotiate and mediate.
- Investigate alleged ceasefire violations, boundary incidents, and complaints.
- Collect information about the disputing forces, using all available assets.
- Contend with ambiguous, tense, or violent situations without becoming a participant, in compliance with the ROE and preparatory training.
- Provide security for prisoner of war exchange.
- Supervise disengagements and withdrawals.
- Assist civil authorities.
- Support local elections.
- Provide relief to refugees and internally displaced persons.
- Assist with demining.
- Restore emergency and basic infrastructure functions.
- Transition to peace enforcement or combat operations. (The TF must train to ensure the force has the ability to respond to a contingency plan requiring an increase in the use of force.)

(2) JP 3-07.3 and FM 3-07 provide additional details on PKO-related tasks. Army forces conducting PKOs rely on the legitimacy acknowledged by all major belligerents and international or regional organizations to obtain objectives. They do not use force unless required to defend the soldiers or accomplish the mission. Intelligence and information operations are important to PKOs to provide force protection and situational understanding and to ensure the success of subordinate PKO-related efforts.

b. **Peace Enforcement.** PEOs involve the application of military force or the threat of military force to compel compliance with resolutions or sanctions designed to maintain or restore peace and order. By definition, PEOs are coercive in nature and rely on the threat or use of force. However, the impartiality with which the peace force treats all parties and the nature of its objectives separates PEOs from war. PEOs support diplomatic efforts to restore peace and represent an escalation from peacekeeping operations.

(1) In peace enforcement operations, the TF may use force to coerce hostile factions into ceasing and desisting violent actions. Usually, these factions have not consented to intervention, and they may be engaged in combat activities. A TF conducting a peace enforcement operation must be ready to apply elements of combat power to achieve the following:

- Forcible separation of belligerents.
- Establishment and supervision of protected areas.
- Sanction and exclusion zone enforcement.
- Movement denial and guarantee.
- Restoration and maintenance of order.
- Protection of humanitarian assistance.
- Relief to refugees and internally displaced persons.
- Support for the return of refugee operations.

(2) The nature of PEOs dictates that Army forces assigned a PEO mission be capable of conducting combat operations. Maintaining and demonstrating a credible combat capability is essential for successful PEOs. Units must be able to apply sufficient combat power to protect themselves and accomplish assigned tasks forcefully. Units must also be ready to transition quickly to peacekeeping, offensive, or defensive operations if required.

c. **Operations in Support of Diplomatic Efforts.** Military support of diplomatic efforts improves the chances for success in the peace process by lending credibility to diplomatic actions and demonstrating resolve to achieve viable political settlements. In addition to or as an integral part of PO, Army forces may conduct operations in support of diplomatic efforts to establish order before, during, and after conflict. While these activities are primarily the responsibility of civilian agencies, the military can support these efforts within its capabilities. Army forces may support diplomatic initiatives such as preventative diplomacy, peacemaking, and peace building.

- *Preventive diplomacy* consists of diplomatic actions taken in advance of a predictable crisis to prevent or limit violence (JP 3-07).
- *Peacemaking* is the process of diplomacy, mediation, negotiation, or other forms of peaceful settlement that arranges an end to a dispute and resolves the issues that led to it (JP 3-07).
- *Peace building* consists of post-conflict actions, predominantly diplomatic and economic, that strengthen and rebuild governmental infrastructure and institutions in order to avoid a relapse into conflict (JP 3-07).

#### **8-4. FOREIGN INTERNAL DEFENSE**

Foreign internal defense (FID) is participation by civilian and military agencies of a government in any action programs taken by another government to free and protect its society from subversion, lawlessness, and insurgency (JP 1-02). The main objective is to promote stability by helping a host nation establish and maintain institutions and facilities responsive to its people's needs. Army forces in foreign internal defense normally advise and assist host-nation forces conducting operations to increase their capabilities.

a. When conducting foreign internal defense, Army forces provide indirect support, direct support, military supplies, military advice, tactical and technical training, and intelligence and logistics support to support a host nation's efforts. Generally, US forces do not engage in combat operations as part of a FID. However, on rare occasions when the threat to US interests is great and indirect means are insufficient, US combat operations may be directed to support a host nation's efforts.

b. The TF's primary roles in nation assistance operations are usually similar to its roles in peace-building operations. If involved in these operations, TFs are most likely to



provide forces rather than lead the effort themselves. Army forces conduct FID operations in accordance with JP 3-07.1 and FM 3-07.

### **8-5. SECURITY ASSISTANCE**

Army forces support security assistance efforts by training, advising, and assisting allied and friendly armed forces. Security assistance includes the participation of Army forces in any of a group of programs by which the US provides defense articles, military training, and other defense-related services to foreign nations by grant, loan, credit, or cash sales in furtherance of national policies and objectives (JP 3-07).

### **8-6. HUMANITARIAN AND CIVIC ASSISTANCE**

Humanitarian and civic assistance (HCA) programs provide assistance to the host nation populace in conjunction with military operations and exercises. In contrast to humanitarian and disaster relief operations, HCA are planned activities. These actions are limited to the following categories:

- Medical, dental, and veterinary care provided in rural areas of a country.
- Construction of rudimentary surface transportation systems.
- Well-drilling and construction of basic sanitation facilities.
- Rudimentary construction and repair of public facilities.

### **8-7. SUPPORT TO INSURGENCY**

The US supports insurgencies that oppose regimes that threaten US interests or regional stability. The US supports only those forces that consistently demonstrate respect for human rights. While any Army force can support an insurgency, Army special operations forces almost exclusively receive these missions. Given their training, organization, and regional focus, SOF are well suited for these operations. Conventional US forces supporting insurgencies may provide logistics and training support but normally do not conduct combat operations.

### **8-8. SUPPORT TO COUNTERINSURGENCY**

Military support to counterinsurgencies is based on the recognition that military power alone is incapable of achieving true and lasting success. More specifically, American military power cannot ensure the survival of regimes that fail to meet the basic needs of their people. Support to counterinsurgency includes, but is not limited to, FID, security assistance, and humanitarian and civic assistance (JP 3-07).

### **8-9. SUPPORT TO COUNTERDRUG OPERATIONS**

Counterdrug operations are always conducted in support of one or more governmental agencies. These include the Coast Guard, Customs Service, Department of State, Drug Enforcement Agency, and Border Patrol of the Immigration and Naturalization Service. Whether operating in the US or in a host nation, Army forces do not engage in direct action during counterdrug operations. Units that support counterdrug operations must be fully aware of legal limitations regarding the acquisition of information on civilians, both US and foreign. Typical support to counterdrug operations includes the following activities:

- Detection and monitoring.
- Host nation support.
- Command, control, communications, and computers.
- Intelligence support.
- Planning support.
- Logistics support.
- Training support.
- Manpower support.
- Research, development, and acquisition.
- Reconnaissance.

When operating inside the US and its territories, counterdrug operations are considered support operations and are subject to restrictions under the Posse Comitatus Act.

### 8-10. COMBATING TERRORISM

Enemies who cannot compete with Army forces conventionally often turn to terrorism. Terrorist attacks often create a disproportionate effect on even the most capable of conventional forces. A mechanized unit, such as a conventional brigade or TF, normally does not participate in counterterrorism. If employed against terrorist forces within an AO, the TF is conducting offensive operations and not conducting counterterrorism. The TF should always utilize antiterrorism measures to reduce the vulnerability of individuals and property to terrorist acts, which include the following:

- Arson.
- Hijacking.
- Maiming.
- Seizure.
- Assassination.
- Hostage taking.
- Sabotage.
- Hoaxes.
- Bombing.
- Kidnapping.
- Raids and ambushes.
- Use of NBC.

a. **Counterterrorism.** Counterterrorism refers to offensive measures taken to prevent, deter, and respond to terrorism (JP 1-02). Counterterrorism is a specified mission for selected special operations forces that are specifically organized and trained to combat terrorism. Commanders who employ conventional forces to strike against organized terrorist forces operating in their area of operations conduct a conventional offensive operation, not counterterrorism.

b. **Antiterrorism.** Antiterrorism includes defensive measures used to reduce the vulnerability of individuals and property to terrorist attacks, including limited response and containment by local military forces (JP 1-02). Typical antiterrorism actions include the following:

- Coordination with local law enforcement.
- Siting and hardening of facilities.

- Physical security actions designed to prevent unauthorized access or approach to facilities.
- Crime prevention and physical security actions that prevent theft of weapons, munitions, identification cards, and other materials.
- Policies regarding travel, size of convoys, breaking of routines, host nation interaction, and off-duty restrictions.
- Protection from weapons of mass destruction.

### **8-11. NONCOMBATANT EVACUATION OPERATIONS**

Army forces conduct noncombatant evacuation operations (NEOs) to support the Department of State in evacuating noncombatants and nonessential military personnel from locations in a foreign nation to the US or an appropriate safe haven. Normally, these operations involve US citizens whose lives are in danger either from the threat of hostilities or from a natural disaster. They may also include selected citizens of the host nation or third-country nationals. The NEO may take place in a permissive, uncertain, or hostile environment and can be either unopposed or resisted by hostile crowds, guerrillas, or conventional forces. Most often, the evacuation force commander has little influence over the local situation. Removing these potential targets expands options available to friendly diplomatic and military authorities. The commander may not have the authority to use military measures to preempt hostile actions, yet he must be prepared to defend the evacuees and his force. A key factor in NEO planning is correctly appraising the political-military environment in which the force will operate. The NEO can be a prelude to combat actions, a part of deterrent actions, or a part of peace operations.

### **8-12. ARMS CONTROL**

TF forces can assist in arms control operations by locating, seizing, and destroying ordinance, weapon systems, and weapons of mass destruction. Other actions include escorting authorized deliveries of weapons and materiel (such as enriched uranium) to preclude loss or unauthorized use, inspecting and monitoring production and storage facilities, and training foreign forces in the security of weapons and facilities. Arms control operations are normally conducted to support arms control treaties and enforcement agencies. Forces may conduct arms control during combat or stability operations to prevent escalation of the conflict and reduce instability. This could include the mandated disarming of belligerents as part of a peace operation. The collection, storing, and destruction of conventional munitions and weapons systems can deter belligerents from reinstigating hostilities.

### **8-13. SHOW OF FORCE**

A show of force is an operation designed to demonstrate US resolve. Shows of force involve increased visibility of US deployed forces in an attempt to defuse a specific situation that, if allowed to continue, may be detrimental to US interests or national objectives (JP 1-02). The show of force can influence other government or political-military organizations to respect US interests and international law. The TF may take part in a show of force by participating in a temporary buildup in a specific region, conducting a combined training exercise, or demonstrating an increased level of readiness. The US conducts shows of force for three principal reasons: to bolster and reassure allies, to deter

potential aggressors, and to gain or increase influence. Although actual combat is not desired when conducting a show of force, the TF commander must be prepared for an escalation to combat.

#### **8-14. PLANNING CONSIDERATIONS**

Stability operations, with the exception of specific actions undertaken in combating terrorism, support to counterdrug operations, and noncombatant evacuation operations, tend to be decentralized operations over extended distances. As such, the TF's activities consist largely of separated small-unit operations conducted across an assigned sector or AO. The TF must conduct these operations with consistency, impartiality, and discipline to encourage cooperation from indigenous forces and garner popular support.

#### **8-15. DECENTRALIZED OPERATIONS**

Subordinate commanders need maximum flexibility in executing their missions. Their commander should give them specific responsibilities and ensure they understand his intent.

a. Commanders must achieve mass, concentration, and their objective and must not become so decentralized as to piecemeal their efforts. The TF creates a common operational picture, utilizing both analog and digital systems (if equipped), which gives the commander improved situational understanding, allowing him to command and control dispersed elements of the TF while still retaining the flexibility to quickly mass forces at the decisive point on the battlefield.

b. Given the volatile and politically charged nature of most stability operations, individual and small-unit actions can have consequences disproportionate to the level of command or amount of force involved. In some cases, tactical operations and individual actions can have strategic consequences. Preventing these problems requires disciplined, knowledgeable leaders and soldiers at every level who clearly understand the TF commander's intent.

#### **8-16. RULES OF ENGAGEMENT**

The ROE are directives issued by competent military authority that explain the circumstances and limitations under which US forces initiate and continue combat engagement with opposition encountered. The ROE reflect the requirements of the law of war, operational concerns, and political considerations when military force shifts from peace activities to combat operations and back to the peace phase of an operation. These requirements are the primary means the commander uses to convey legal, political, diplomatic, and military guidance to the military force for handling the crisis in peacetime.

a. Tactical and legal channels cooperate closely when formulating ROE. The commander determine the desired intent of the ROE; the SJA puts that intent into legal terms.

b. Generally, the commander permits a wider use of military force in wartime through ROE. The ROE restrict the use of military force to achieve the political objectives. In all operations, the commander is legally responsible for the care and treatment of civilians and property in the AO until transferred to a proper government. The ROE assist the commander in fulfilling these responsibilities. They vary in different

conflicts and often change during the respective phases from combat or crisis through peace-building or nation assistance. Even during a single phase of operation, the rules are amended at different levels of command, which may result in confusion.

c. The ROE must be consistent with training and equipment capabilities. When necessary, command guidance clarifies the ROE. While the rules must be tailored to the situation, TF commanders should observe that nothing in such rules negates their obligation to take all necessary and appropriate action in unit self-defense, allowing soldiers to protect themselves from deadly threats. The ROE rule out the use of some weapons and impose special limitations on the use of weapons. Examples include the requirements for warning shots, single shot engagements, and efforts to wound rather than kill. A TF deploying for stability operations trains its soldiers to interpret and apply the ROE effectively. It is imperative for everyone to understand the ROE since small-unit leaders and individual soldiers must make ROE decisions promptly and independently.

d. The ROE are normally developed with political considerations in mind and come from joint chief of staff-(JCS-)level decisions. Changes to the ROE can result from immediate tactical emergencies at the local level. The commander should be able to request changes to the ROE. Changes are requested through the operational chain of command and must be approved by the designated authority, usually division or higher-level command. Commanders at all levels need to know the request channels for ROE as well as the procedures to obtain approval for recommended changes to the ROE. Situations requiring an immediate change to the ROE could include introduction of combat forces from a hostile nation, attacks by sophisticated weapons systems including NBC, or incidents resulting in loss of life. These situations should be war-gamed and special instructions included in all OPORD and or FRAGOs that specifically state when and how commanders at all levels can adjust the ROE.

e. The ROE are established for, disseminated down to, and understood by individual soldiers. However, the ROE cannot cover every situation. Soldiers at all levels must understand the intent of the ROE and act accordingly despite any military disadvantage that may occur. The commander responsible for ROE formulation should consider including an intent portion that describes the desired end state of the operation as well as conflict-termination considerations. The intent portion should provide a framework for a measured response (gradual increase) in the use of force. These considerations assist commanders and leaders at all levels in situations not clearly addressed in an OPORD. Further, ROE must be an integral part of all predeployment training.

## **8-17. RULES OF INTERACTION**

The rules of interaction (ROI) embody the human dimension of stability operations; they lay the foundation for successful relationships with the myriad of factions and individuals that play critical roles in these operations. The ROI encompass an array of interpersonal communication skills such as persuasion and negotiation. These skills are the tools that the individual soldier needs to deal with the nontraditional threats that are prevalent in stability operations, including political friction, unfamiliar cultures, and conflicting ideologies. In turn, ROI enhance the soldier's survivability in such situations. The ROI are based on the applicable ROE for a certain operation. The ROI must be tailored to the specific regions, cultures, and populations affected by the operation. Like ROE, ROI can

be effective only if they are thoroughly rehearsed and understood by every soldier in the unit.

### **8-18. FORCE PROTECTION**

Force protection requires special consideration in stability operations. Opposing forces may seek to kill or wound US soldiers for political purposes rather than tactical objectives. Commanders attempt to accomplish a mission with minimal loss of personnel, equipment, and supplies by integrating force protection considerations into all aspects of operational planning and execution. Commanders and leaders throughout the TF deliberately analyze their missions and environments to identify threats to their units. They then make their soldiers aware of the dangers and create safeguards to protect them. Commanders must always consider the aspects of force protection and how they relate to the ROE to include the following:

- Cooperate with the host nation .
- Avoid becoming a lucrative target or developing a predictable pattern of activities.
- Include security in each plan, SOP, OPORD, and movement order.
- Develop specific security programs such as threat awareness and OPSEC.
- Restrict access of unassigned personnel to the unit's location.
- Constantly maintain an image of professionalism and readiness.
- Consider force protection throughout the range of military operations; base the degree of security established on a continuous threat assessment.
- Force protection consists of OPSEC, deception, health and morale, safety, and avoidance of fratricide.

a. **Operations Security.** OPSEC considerations include the following:

(1) Communications security is as important in stability operations as it is in conventional military operations. Belligerent parties can monitor telephones and radios.

(2) Maintaining neutrality contributes to protecting the force. In stability operations, the entire force safeguards information about deployment, positions, strengths, and equipment of one side from the other. If one side suspects that the force is giving information to the other side, either deliberately or inadvertently, one or both parties to the dispute may become uncooperative and jeopardize the success of the operation, thus putting the force at risk from this loss of legitimacy.

(3) The force must take precautions to protect positions, headquarters, support facilities, and base camps. These precautions may include obstacles and fortifications. Units also practice alert procedures and develop drills to occupy positions rapidly. A robust engineer force provides support to meet survivability needs.

(4) MP forces establish and maintain roadblocks. If MP forces are unavailable, other forces may assume this responsibility. As a minimum, the area should be highly visible and defensible with an armed overwatch.

(5) The single most proactive measure for survivability is individual awareness by soldiers in all circumstances. Soldiers must look for things out of place and patterns preceding aggression. Commanders should ensure soldiers remain alert, do not establish a routine, maintain appearance and bearing, and keep a low profile.

b. **Health and Morale.** Stability operations often require special consideration of soldier health, welfare, and morale factors. These operations frequently involve

deployment to an austere, immature theater with limited life support infrastructure. Commanders must consider these factors when assigning missions and planning rotations of units into and within the theater.

c. **Safety.** Commanders in stability operations may reduce the chance of mishap by conducting risk assessments, assigning a safety officer and staff, conducting a safety program, and seeking advice from local personnel. The safety program should begin with training conducted before deployment and be continuous. Training includes the effect on safety of factors such as the environment, terrain, road conditions and local driving habits, access to or possession of live ammunition, unlocated or uncleared mine fields, and special equipment such as armored vehicles and other systems that present special hazards.

d. **Avoidance of Fratricide.** Most measures taken to avoid fratricide in stability operations are no different than those taken during combat operations. However, commanders must consider other factors such as local hires or NGO personnel that may be as much at risk as US forces. Accurate information about the location and activity of both friendly and hostile forces and an aggressive airspace management plan assist commanders in avoiding fratricide.

## 8-19. TASK ORGANIZATION

In conducting stability operations, the TF commander organizes his assets for the type of mission he must perform, integrating attached assets and the assets from higher headquarters to accomplish the mission. The TF organization must enable the unit to meet changing situations; thus, the commander must consider which resources to allocate to company teams and which to maintain control of at the TF headquarters. Task organization and support arrangements change frequently during long-term stability operations. Commanders must frequently shift the support of engineers, medical units, and aviation units from one area or task to another.

a. **Augmentation.** The unique aspects of stability operations may require individual augmentees and augmentation cells to support unique force-tailoring requirements and personnel shortfalls. Augmentation supports coordination with the media, government agencies, NGOs and other multinational forces, and civil-military elements. METT-TC considerations drive augmentation.

b. **Liaison.** Commanders may consider task organizing small liaison teams to deal with situations that develop with the local population. Teams can free up maneuver elements and facilitate negotiation. Teams must have linguists and personnel who have the authority to negotiate on the behalf of the chain of command. Unit ministry, engineers, CA, counterintelligence, linguistics, and logistics personnel may be candidates for such teams. Commanders must provide augmenting team members with resources and quality of life normally provided to their own soldiers.

## 8-20. MEDIA CONSIDERATIONS

The presence of media is a reality that confronts every soldier involved in stability operations and support operations.

a. All leaders and soldiers are subject to instantaneous worldwide scrutiny as a result of the growth of news coverage via international television and radio broadcasts and the Internet. Those opposed to the operation who are anti-US personnel may interpret or

embellish interviews to imply that the operation counters official US policy and may damage the nation's interests and international standing.

b. TF soldiers must learn how to deal effectively with broadcast and print reporters and photographers. Training should cover any information restrictions imposed on the media. Soldiers must also gain an understanding of which subjects they are authorized to discuss and which ones they must refer to higher authorities, such as their chains of command or the public affairs office (PAO). PAO personnel usually issue daily guidance dealing with these subjects.

### **8-21. OPERATIONS WITH OUTSIDE AGENCIES**

US Army units conduct certain stability operations in coordination with a variety of outside organizations. These include other US armed services or government agencies as well as international organizations (including NGOs, and UN military forces or agencies). Coordination and integration of civilian and military activities must take place at every level. Operational and tactical headquarters plan their operations to complement those of government and private agencies. Likewise, military commanders need to make clear to other agencies their own objectives and operational schemes. Coordinating centers such as the civil-military operations center are designed to accomplish this task. These operations centers should include representatives from as many agencies as required.

### **8-22. SPECIFIC CONSIDERATIONS BY BOS**

The TF commander must clearly understand the mission and the situation, and he must ensure his staff and subordinate units understand these as well. He must plan for continuous operations and, as with offensive and defensive operations, planning and preparation time is often very limited. The plan must facilitate adjustment based on changes in the situation. The commander and his staff must consider--

- The mission: What the force is expected to do.
- The AO (such as size, location, terrain, and weather).
- The political, economic, military, and geographical situation in their AO.
- Local customs, cultures, religions, ethnic groups, and tribal factions.
- The importance of force protection, OPSEC, physical security, and permissible protection measures.
- The ROE and appropriate actions to take concerning infringements and violations of agreements.
- Physical considerations (such as minefields, bridges, road conditions, and existing infrastructure).
- Security operations.
- Use of additional assets such as intelligence, public affairs, civil affairs, psychological operations, engineers, and MPs.

The TF commander influences and shapes the AO for mission success by effectively using buffer zones to separate belligerent factions, establishing checkpoints to control movement through and within the TF area, and conducting cordon and search operations to isolate and locate belligerents. To plan effective stability operations, the commander must consider his AO and the environment. All planning should provide a reserve of appropriate size to separate hostile parties before potentially violent situations grow out



of control. The reserve must have the ability to respond anywhere in the TF area and handle any unforeseen crisis.

### 8-23. INTELLIGENCE

Reconnaissance plays an important role in the TF's accomplishment of a stability mission. The TF commander uses every element available to collect information that helps him accomplish his mission. He uses these elements in compliance with the ROE. Every member of the TF plays a role in gathering information to support the TF. The TF commander uses his TF S2 and the TF intelligence section to form intelligence collection teams. They manage the intelligence collection effort to ensure every member of the TF understands the intelligence required and plays an active role in the collection of that intelligence. Intelligence collection elements normally available to the TF include the scout platoon, maneuver company teams, elements attached to or supporting the TF, and soldiers on patrols in OPs and at checkpoints.

a. **Other Collection Elements.** In addition to organic elements, the TF may have interrogation, counterintelligence, or signal intelligence elements from the divisional MI battalion or corps MI brigade attached.

b. **Human Intelligence.** The attitudes and perceptions of the local populace in the AO are important in helping the TF commander decide how to use his forces to accomplish his objectives. HUMINT, whether collected by TF or supporting elements, is a primary means the TF uses to understand the attitudes and perceptions of the local populace.

c. **IPB Applied to Stability Operations.** The TF commander uses the IPB process and the intelligence cycle as cornerstones for successful stability operations. They can help the commander determine who the enemy is, what capabilities the enemy has, and where he can find the enemy. In an asymmetrical environment, the focus will be on pattern analysis versus predictive analysis when the order of battle (OB) is better defined. They also serve as the basis for creating the TF concept of operations and allocating combat power available to the TF. (See FM 34-130 for more information on IPB and how it applies to stability operations.) Although some of the traditional IPB products, such as the warfighting templates, may not be applicable, the methodology remains intact. The development of detailed PIR and IR enables all personnel in the AO to gather critical information to support the TF. A part of IBP is to assess the area in which the TF will be operating. (See Table 8-1 for an area assessment checklist.)

<b>AREA ASSESSMENT CHECKLIST</b>
<b>Refugee Interaction</b>
Where are the refugees originally from?
What is the size of the original population?
What are the size and population of the surrounding countryside the village services?
What is the size of the refugee population?
Why did they come here?
What is the relationship of the village with the surrounding villages? Are they related? Do they support each other? Are they hostile? Is any portion of the population discriminated against?
<b>Food and Water</b>
What is the food and water status of the village?
Where do they get their food?
What other means of subsistence are available?
Are the villagers farmers or herders?
What is the status of their crops or herds?
What is the quality of the water source?
<b>Medical Surveillance</b>
What is the medical status of the village?
What services are available in the village? In the surrounding countryside?
Is there evidence of illness or starvation?
What portion of the population is affected?
What is the death rate?
What diseases are present in the village?
<b>Civil-Military/Nongovernmental Organizations</b>
What civilian and military organizations exist in the village or surrounding countryside?
Who are their leaders?
Which organization, if any, does the local populace support?
<b>United Nations or other Relief Agencies</b>
What NATO, UN, or other relief agencies operate in the village?
Who are their representatives?
What services do they provide?
What portion of the population do they service?
Do they have an outreach program for the surrounding countryside?
<b>Commerce</b>
What commercial or business activities are present in the village?
What services or products do they produce?
<b>Miscellaneous</b>
Determine the groups in the village in the most need. What are their numbers? Where did they come from? How long have they been there? What are their specific needs?
What civic employment projects would village leaders like to see started?
Determine the number of families in the village. What are their family names? How many in each family?
What food items are available in the local market? What is the cost of these items? Are relief supplies being sold in the market? If so, what items, from what source, and at what price?
What skilled labor or services are available in the village?
What are the major roads and routes through the village? How heavily traveled are they? Are there choke points or bridges on the routes? Are there alternate routes or footpaths?
What is the size of any transient population in the village? Where did they come from and how long have they been there?

**Table 8-1. Area assessment checklist.**

d. **Information Operations.** Information operations focus on shaping the ideas, perceptions, and beliefs of friendly, neutral, and belligerent forces. The successful management of information helps give the commander the ability to affect the perception of the local population, belligerent factions, and local leaders and to accomplish his mission. Information management is crucial in stability operations, and security of elements which can help manage information is a critical task. The TF commander may have PSYOP, CA, public affairs, and OPSEC elements attached or operating in support of his TF. If he must plan for their use, he must do so in concert with the rules of engagement, the order from higher headquarters, and his operational plan. If these elements are operating in his area, he may be responsible for providing security for them. Sources of information the TF must use include:

- Neutral parties.
- Former warring factions.
- Civilian populace.
- Other agencies working in the AO.
- Media and information passed from organic and nonorganic assets.

#### **8-24. MANEUVER**

TF maneuver in stability operations is similar to maneuver in traditional combat operations, with extensive emphasis on security. The intent is to create a stable environment that allows peace to take hold while ensuring the force is protected.

a. **Battalion Task Force Maneuver.** Maneuver of the TF in stability operations is often decentralized to the company or platoon level. As required, these units receive relief from support forces such as engineers, logistics, and medical personnel. The TF commander must be prepared to rely on CS and CSS elements to assist the maneuver forces when the need arises. When new requirements develop, the CS and CSS elements must be ready to shift priorities.

b. **Combat Maneuver.** Maneuver may involve combat. The TF uses only the level of force necessary to stabilize the crisis. Depending on the ROE, the TF may precede the use of force with a warning or the use of nonlethal means, employing lethal means only if a belligerent does not stop interfering. The methods employed to reduce the crisis could take the form of separating belligerent forces or maneuvering TF elements to provide security. A show of force or demonstration may be all that is necessary, or the TF may employ patrolling, searches, negotiation and mediation, information gathering, strikes and raids, or combat operations to accomplish the mission.

#### **8-25. AVIATION SUPPORT**

Aviation units--which can be deployed into the area of operation with early-entry ground forces--can be a significant deterrent on the indigenous combatants, particularly if these factions have armored or mechanized infantry forces. Observation or attack helicopters may be employed to act as a TCF or as a reaction force against enemy threats. They may also conduct reconnaissance and surveillance over wide areas and provide the TF a means for visual route reconnaissance. Utility helicopters provide an excellent enhanced command and control capability to stability operations. Medium lift helicopters are capable of moving large numbers of military and civilian peace enforcement personnel

and delivering supplies when surface transportation is unavailable or routes become impassable.

### **8-26. FIRE SUPPORT**

Although FS planning for stability operations is the same as for traditional combat operations, the use of FS may be very restricted and limited. The commander integrates FS into his tactical plan IAW the ROE and restrictions imposed by the AO, such as no-fire zones, presence of noncombatants, and so forth. Special considerations include--

- Procedures for the rapid clearance of fires.
- Close communication and coordination with host country officials.
- Increased security for indirect firing positions.
- Restricted use of certain munitions such as DPICMs, area denial artillery munitions (ADAMs), or remote antiarmor mines (RAAMs).

### **8-27. MOBILITY AND SURVIVABILITY**

Mobility in the TF AO may be restricted due to poorly developed or significantly damaged road systems, installations, and airfields. Before the TF can maneuver effectively, the TF must prepare the AO to support that maneuver. This restricted mobility and need for the TF to maneuver effectively may cause higher headquarters to augment the TF with engineer assets.

a. Engineers can play a major role in stability operations by constructing base camps, upgrading the transportation infrastructure, conducting bridge reconnaissance, assisting in civic action by building temporary facilities for the civilian populace, and reducing the mine threat. Additionally, if the AO is heavily saturated with mines, engineers can be used to establish a mine action center (MAC) to provide centralized control for de-mining operations. Factors that help determine the amount of engineer support the TF receives include--

- Terrain in the AO.
- Minefields in the AO
- Type and location of obstacles in the AO.
- Engineer assets available.
- Duration of the operation.
- Environmental considerations.
- Water supply and location.
- Sewage and garbage facilities.
- Local power facilities.
- Firefighting capability.
- Basic country infrastructure (road, bridge, rail, airfield, and port capability), including contracted engineering support.

b. Regardless of TF requirements, there may not be enough engineer assets, including civilian contract engineer support, available. This situation requires TF elements to construct their own fortifications and assist with other engineer tasks within their capabilities. In prioritizing the use of engineers or the use of organic forces to accomplish engineer tasks, the TF commander emphasizes the strengthening of force protective measures.

**8-28. AIR DEFENSE**

The ADO thoroughly analyzes enemy air capabilities during the initial stages of planning. If an air threat exists or is possible, the ADO must take care to use organic and any attached ADA elements to combat the threat in full compliance with the ROE. Since a belligerent air capability can disrupt the TF's entry into and operations in the AO, the TF must ensure information concerning it remains a priority intelligence collection requirement.

**8-29. COMBAT SERVICE SUPPORT**

The TF's ability to sustain itself in the AO depends on the theater's maturity, the CSS structure, and the time flow of forces. Refugees, an inadequate infrastructure, and demands by the host nation and coalition partners can make logistical support complex.

a. **General Principles.** General principles to consider when planning CSS for stability operations include--

- Ability to implement logistical support in any stability operations area.
- Ability of the TF to provide its own support.
- Ability of higher headquarters to provide support.
- Availability of local supplies, facilities, utilities, services, and transportation support systems by contract or local purchase.
- Availability of local facilities such as LOCs, ports, airfields, and communications systems.
- Local capabilities for self-support to facilitate the eventual transfer of responsibilities to the supported nation for development or improvement.
- Availability of resources.

b. **Augmentation.** To make up for inadequate logistical and health service infrastructures in the AO, the TF may be augmented with additional CSS elements. Some or all of these CSS elements may precede combat or CS elements into the AO. In addition to supporting the TF, CSS elements may provide support for--

- Allied or indigenous governmental agencies.
- Allied or indigenous civilians.
- Allied or indigenous military forces.
- US governmental agencies.
- US civilian agencies and personnel.
- Other US military forces.
- US-backed personnel and organizations.
- International civilian and governmental agencies.

c. **Health Services Support.** In stability operations, the brigade deploys with its organic medical assets. In addition, the FSMC will be augmented with a forward surgical team and a forward support medical evacuation team (FSMT). Health services support for the TF in stability operations is dependent upon the specific type of operations, anticipated duration of the operations, number of personnel deployed, evacuation policy, medical troop ceiling, and anticipated level of violence. Additional HSS requirements could include veterinary services, preventive medicine (PVNTMED), hospital, laboratory, combat/operational stress control, and dental support. For definitive information on HSS for stability operations, see FM 8-42. See AR 40-3 for information on emergency medical treatment for local national civilians during stability operations.

d. **Contracting.** Contracting can be an effective force multiplier and can augment existing CSS capabilities. Weak logistical infrastructures in the AO may make it necessary to use contracting for some supplies and services. If he knows that contracting functions may have to be performed, the TF commander obtains guidance from higher headquarters concerning contracting during the initial planning stages. Hostilities can cause interruptions in the delivery of any contracted services, such as food and water, so the TF must be prepared to support itself and provide necessary support to attached and supporting forces and the local populace for limited periods of time. A good plan anticipates large consumption rates of supplies in Classes I, III, IV, and VIII and provides for reserve stockage of nonperishables.

### **8-30. COMMAND AND CONTROL INFORMATION SYSTEMS**

Battalion task forces and brigades do not normally perform the function of a joint headquarters. If there is no joint task force (JTF) for the operation, a command and control element from the division performs the role of the JTF to integrate the other services. This allows the TF to focus on the control of its company teams. If a battalion task force follows a SOF unit or operation during a deployment, it should request a liaison before arrival in the operational area. The TF coordinates with SOF through the JTF. If there is no JTF, the unit contacts the SOF through the security assistance office.

a. **Command and Control.** The commander develops and articulates a desired end state in terms of the military and desired socioeconomic conditions that have the greatest potential for lasting stability in the area. The commander and his staff determine the required sequence of tasks and objectives the TF must accomplish to meet the end state. Other critical actions include moving into the AO, establishing a base of operations and sustainment for the TF, and implementing appropriate force protection policies. As the immediate situation stabilizes, the TF conducts follow-on actions to restore order and local government, assist in repairing infrastructure, remove weapons, and disarm factions. The commander and staff assign objectives and AOs, allocate forces, and establish control measures for subordinate forces to accomplish their missions.

(1) To keep the TF focused throughout the operation, the commander and his staff develop a concept of the operation that establishes objectives and timelines to meet the desired end state. The concept should cover the entire duration of the operation from deployment to the end state, defining how the TF will accomplish its assigned mission. The commander uses FRAGOs and subsequent OPORDs to control execution of each phase of the operation and various missions as required.

(2) The commander and his staff coordinate TF plans and actions with the higher headquarters, adjacent units, and government and nongovernmental organizations in the AO to ensure unified effort. Use of LNOs is vital for this requirement.

b. **Communications.** Communications abilities are augmented to effect long-range communications and proper liaisons. The commander and his staff consider equipment compatibility, crypto use, information sharing, and security measures when working with SOF, joint forces, and multinational forces.

c. **Intelligence Considerations.** The TF uses the IPB to portray the intelligence estimate for the commander. Population status, ethnicity, and socioeconomic factors take on increasing importance. Enemy doctrinal information may be scarce. HUMINT is a

major focus, and the intelligence effort must be continuous. (See FM 34-130 for more information on IPB for stability and support operations.)

(1) **Organizations.** Organization sources include all host country military and civilian intelligence systems as well as US intelligence sources.

(2) **Collection.** Tactical collection includes all sources. Technological capabilities may not provide a significant advantage in some environments. An intelligence database may or may not apply, or be available, to the tactical commander. The focus of the IPB, and the main source of intelligence, is often HUMINT. Every soldier must be a collector.

(3) **Restrictions.** Internal and external restrictions may exist on the dissemination of information. Gathering information on and within another country in operations other than war has political sensitivity.

(4) **Emphasis.** The intelligence effort must have continued emphasis. Before force commitment, the TF must effectively collect, process, and focus intelligence to support all planning, training, and operational requirements. During execution, intelligence determines the proper course of action.

### 8-31. TECHNIQUES

During stability operations the TF may conduct patrols, man observation posts, guard officials, maintain static security posts, conduct searches and roadblocks, react to a civil disturbance, and conduct checkpoint operations in order to accomplish the mission. Additionally, indigenous authorities or other high-ranking officials may require the protection of the battalion task force during movement through or within the area of operations.

### 8-32. PRESENCE PATROLS

The battalion task force may direct its subordinate company teams to conduct patrols, either mounted, dismounted, or by aircraft. Although the patrols are conducted overtly, the company teams take all precautions to protect the soldiers on patrol. A patrol must be readily identifiable as such by all parties and must conduct movement openly. The patrol wears distinctive items of uniform, such as the American flag and non-subdued unit patches.

- a. Patrols can accomplish the following:
  - Deter potential truce violations by maintaining a presence.
  - Cover gaps between fixed observation posts.
  - Confirm reports from observation posts.
  - Investigate alleged breaches of the armistice.
- b. A patrol must do the following:
  - Avoid deviating from the planned route.
  - Record in writing and sketch all observations.
  - Halt when challenged, identify itself, and report any attempt to obstruct its progress.
  - Record any changes in the disposition of the opposing forces.

### 8-33. OBSERVATION POSTS

Observation posts are an especially important element of the battalion task force's effort to establish and maintain operational security. OPs provide protection when long-range

observation from current positions is not possible. The TF may task the company teams to employ OPs, either mounted or dismounted, as the situation dictates.

a. OPs are sited for maximum view of the surrounding area, for clear radio communications, and for defensibility. OP locations are recorded, and the commander must authorize any relocation. Soldiers man the OPs at all times and access is limited to authorized personnel only. The mission of the OP is to report the following:

- Movement of belligerent military forces, including unit identification, time, direction, and other details that the OP can ascertain.
- Shooting, hostile acts, or threats directed against the peacekeeping force or civilians.
- Any improvement to defensive positions of a former belligerent.
- An overflight by unauthorized aircraft, either military or civilian, including the time, direction, aircraft type, and nationality.
- Any observed violations of an armistice agreement.

b. The peacekeeping force ensures its safety through security, self-defense, and force protection. Conspicuous marking on installations, vehicles, and personnel are a source of protection. The peacekeeping force maintains its legitimacy and acceptability to the former belligerents through its professional, disinterested, and impartial conduct of the peacekeeping mission. However, factions in the former belligerents' armed forces, in the civilian population, or among other interested parties may want to disrupt the peacekeeping operation and subvert the diplomatic process. Therefore, the peacekeeping force must be prepared to defend itself.

c. The TF must strictly follow the ROE and limitations on the use of force. Each unit must maintain a ready reserve that can reinforce an OP or aid a patrol in distress. Field fortifications, barriers, and well-sited weapons must protect installations, and the TF must take precautions to protect personnel and facilities from terrorist attacks. The peacekeeping force must fight defensive engagements only if they cannot avoid such engagements. The commander must be prepared to recommend withdrawal of the force when a serious threat appears.

#### **8-34. PROVIDING SECURITY FOR INDIGENOUS AUTHORITIES**

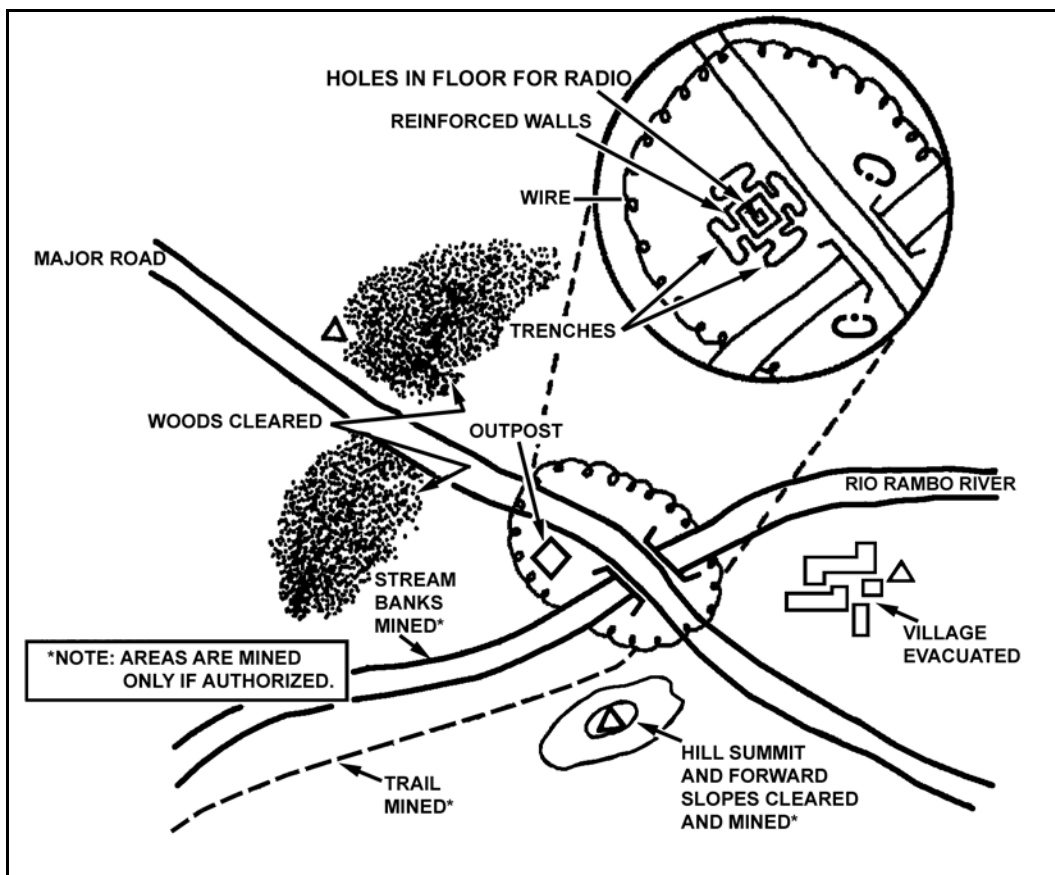
Indigenous authorities or other high-ranking officials may require the protection of a military escort when moving within the area of operation.

- a. The strength of the escort required depends on the circumstances.
- b. The TF escort force should provide an armored vehicle as optional transportation for the official(s).
- c. Additional vehicles must provide support to the vehicle carrying the official(s) throughout the move. Each of the additional vehicles should have automatic weapons and soldiers designated to provide security for the officials.
- d. The escort force protects the official(s) in the event of an attack. It gets the official vehicle out of the danger area as quickly as possible. The escort force must develop and rehearse contingency plans, alternate routes, and actions in case of attack.
- e. Before starting the move, the escort commander briefs the official(s) about what will be done in the event of an attack. Regardless of the official's seniority, the escort commander is in command of the move.



### 8-35. STATIC SECURITY POSTS

A static security post (Figure 8-1) is any security system organized to protect critical fixed installations--military or civil--or critical points along lines of communication such as terminals, tunnels, bridges, and road or railway junctions.



**Figure 8-1. Security post.**

a. The size of the post depends on the mission, the size and characteristics of the hostile force, the attitude of the civil populace, and the importance of the item being secured. The post varies from a two-man bridge guard to a reinforced company team securing a key communications center or civilian community. The TF coordinates establishment of security posts with the host nation.

b. The organization of a static security post varies with its size, mission, and distance from reinforcing units. For security reasons, static security posts in remote areas are larger than the same type post would be if located closer to supporting forces. It is organized for the security of both the installation and the security force. The TF must establish reliable communications between remote static security posts and the parent unit's base.

c. The TF must control access by indigenous personnel to the security post. It screens and evacuates people living near the positions and can place informers from the local population along the routes of approach.

d. The commander must give all possible consideration to soldier comfort during the organization and preparation of the security post. Even under the best conditions, morale

suffers among soldiers who must operate for prolonged periods in small groups away from their parent organization.

e. If the static security post is far removed from other TF units and might be isolated by enemy action, the TF prestocks sustaining supplies there in sufficient quantities. A static security post should never have to depend solely on the local populace for supplies.

### **8-36. SEARCHES**

Searches are an important aspect of populace and resource control. The need to conduct search operations or to employ search procedures is a continuous requirement. A search can orient on people, materiel, buildings, or terrain. A search usually involves both civil police and soldiers.

a. **Planning Considerations.** Misuse of search authority can adversely affect the outcome of operations; thus, soldiers must conduct and lawfully record the seizure of contraband, evidence, intelligence material, supplies, or other minor items for them to be of future legal value. Proper use of authority during searches gains the respect and support of the people.

(1) Authority for search operations is carefully reviewed. Military personnel must perform searches only in areas in military jurisdiction (or where otherwise lawful). They must conduct searches only to apprehend suspects or to secure evidence proving an offense has been committed.

(2) Search teams have detailed instructions for handling controlled items. Lists of prohibited or controlled-distribution items should be widely disseminated and on hand during searches. The TF contacts military or civil police who work with the populace and the resource control program before the search operations (or periodically if search operations are a continuing activity). Units must consider the effect of early warning on the effectiveness of their operation.

(3) Language difficulties can interfere when US forces conduct search operations involving the local populace. The US units given a search mission are provided with interpreters as required.

(4) The TF conducts search operations slowly enough to allow for an effective search but rapidly enough to prevent the enemy from reacting to the threat of the search.

(5) Soldiers use minimum-essential force to eliminate any active resistance encountered.

(6) Searchers can return to a searched area after the initial search to surprise and eliminate insurgents or their leaders who might have either returned or remained undetected during the search.

(7) The TF should develop plans for securing the search area (establishing a cordon) and for handling detained personnel.

(8) Smuggling operations are a major means of financing and sustaining continued hostilities in peace operations. Failure to disrupt or stop smuggling operations will hinder mission success. Special IPB emphasis must be directed toward determining--

- Which items to focus on.
- Techniques or disguises used.
- Transportation assets used.
- Identifying adaptations to US measures.

- Specialized search techniques.
- Identifying entry points, drop-off points, delivery sites, or locations for transshipment of contraband.

b. **Procedures.** Search procedures are as follows.

(1) **Search of Individuals.** In all search operations, leaders must emphasize the fact that anyone in an area to be searched could be an insurgent or a sympathizer. To avoid making an enemy out of a suspect who may support the host country government, searchers are tactful. The greatest caution is required during the initial handling of a person about to be searched. One member of the search team covers the other member, who makes the actual search. (FM 3-19.40 and STP 19-95B1-SM discuss the procedure for searching people.). Units may want to consider using digital cameras for photographing search operations on static observation posts or in routine searches in order to maintain a database on local nationals and to assist in future training.

(2) **Search of Females.** The enemy can use females for all types of tasks when they think searches might be a threat. To counter this, use female searchers. If female searchers are not available, use doctors, aidmen, or members of the local populace.

(3) **Search of Vehicles.** Searching of vehicles may require equipment such as detection devices, mirrors, and tools. Specially trained dogs can locate drugs or explosives. A thorough search of a vehicle is a time-consuming process, and leaders must consider the effect on the population. Use of a separate vehicle search area can help avoid unnecessary delays.

(4) **Search of Urban Areas.** These searches are also referred to as cordon and search operations. The principles, command and control, and procedures for this type of search are discussed in the following paragraph. When intelligence identifies and locates members of the insurgent infrastructure, an operation is mounted to neutralize them. This operation should be done by police acting on the warrant of a disinterested magistrate and based on probable cause. In the more violent stages of an insurgency, emergency laws and regulations may dispense temporarily with some of these legal protections. Use the least severe method to accomplish the mission adequately. Take care to preserve evidence for future legal action.

c. **Cordon and Search.** These operations require superb discipline and particular attention to detail. A cordon and search involves two incendiary processes: limiting freedom of movement and searching dwellings. These two actions provide a clear potential for negative consequences; thus, organizing cordon and search elements requires extensive mission tailoring. Commanders must always be prepared for a civil disturbance. The commander should divide the area to be searched in a built-up area into zones and assign a search party to each. The cordon consists of two parts (an outer and inner cordon). The outer cordon is usually the responsibility of the parent headquarters as it requires a considerable amount of assets to effectively control it. The outer cordon consists of a security element (to encircle the area, to prevent entrance and exit, and to secure open areas) augmented with the necessary combat multipliers (based on METT-TC) such as linguists and civil affairs specialists. The inner cordon is established by the unit assigned the search mission. The higher headquarters must also establish a reserve element to assist either element, as required (Figure 8-2 and Figure 8-3, page 8-26).

(1) **Establishing the Cordon.** An effective inner and outer cordon is critical to the success of the search effort. Cordons are designed to isolate the area to be searched in

order to protect the forces conducting the operation. Leaders should always plan for checkpoints and or roadblocks, patrols, aerial surveillance, engineers, PSYOP, search and entry teams, MPs, and documentation teams. Integration of combat multipliers is critical to success. In remote areas, the TF may establish the cordon without being detected. The use of limited visibility aids in the establishment and security of the cordon but makes it difficult to control. The TF must enforce the ROE and should develop plans to handle detained personnel. Infantrymen accompany police and intelligence forces to identify, question, and detain suspects. Infantry may also conduct searches and assist in detaining suspects, under police supervision; their principal role, however, is to reduce any resistance that may develop and to provide security for the operation. Use of force is kept to a minimum. Deployment for the search should be rapid, especially if the enemy is still in the area to be searched. Ideally, the entire area should be surrounded at once. Observed fire covers any gaps. The security element surrounds the area while the search element moves in. Members of the security element orient mainly on people evading the search in the populated area. The security element can also cut off any insurgents trying to reinforce others within the area, isolating the search area internally and externally. Checkpoints and roadblocks are established. Subsurface routes of escape in built-up areas, such as subways and sewers, may also need to be searched and blocked.

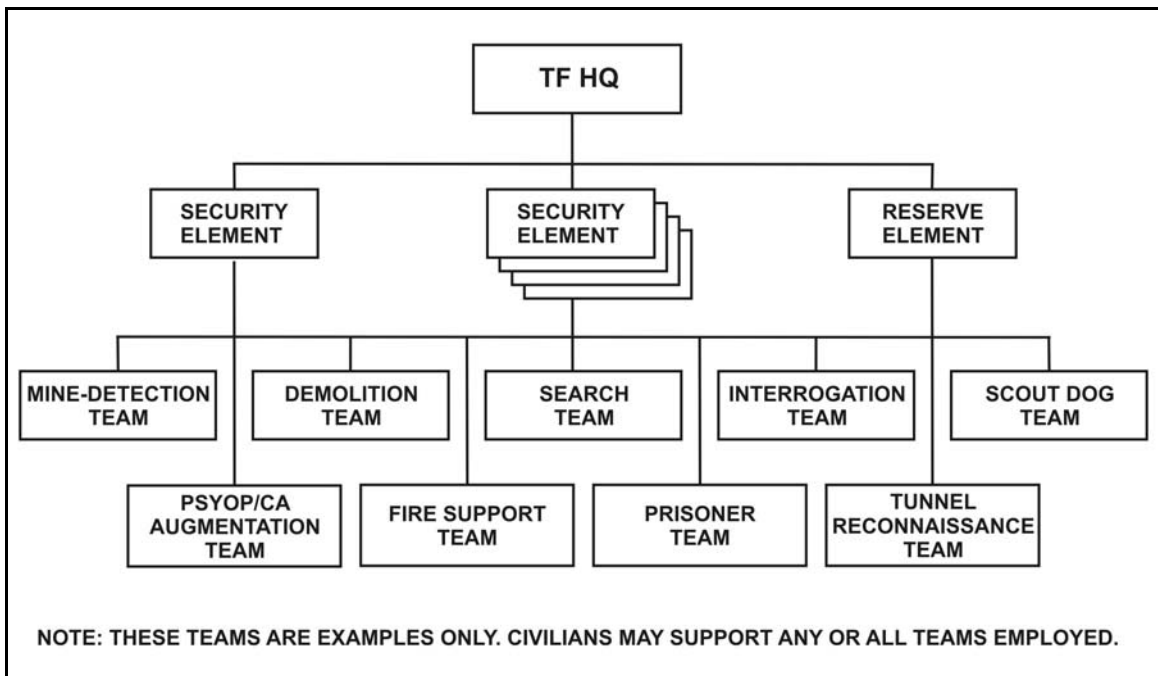
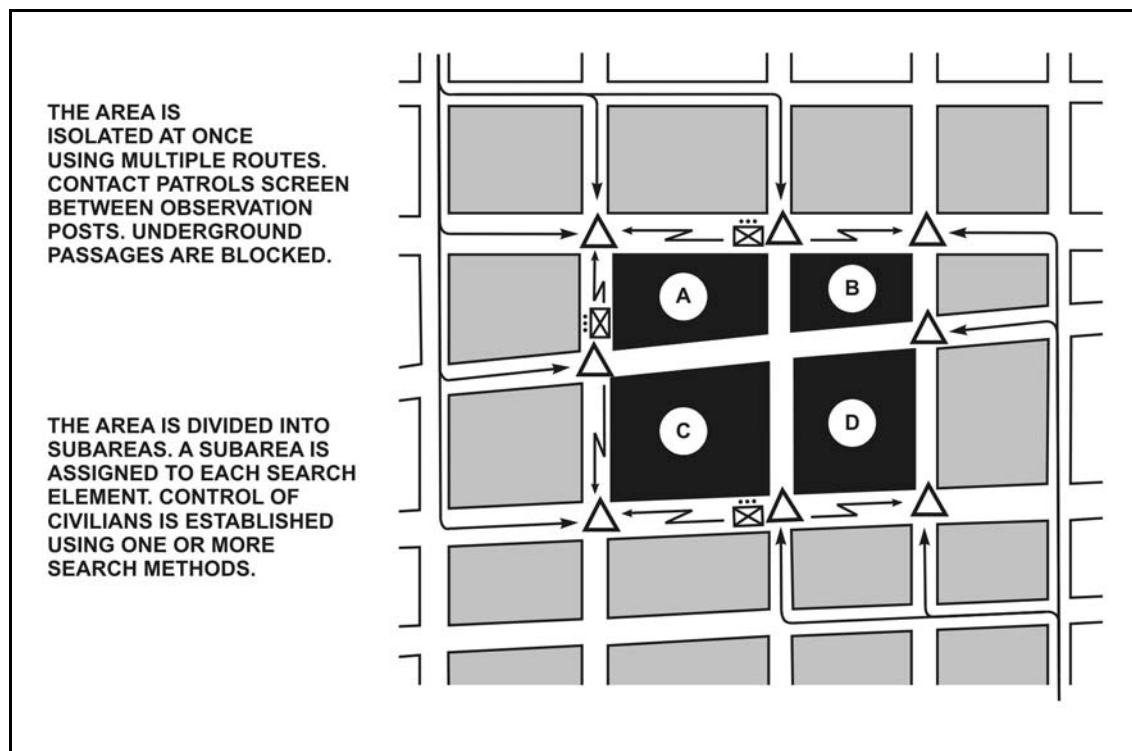


Figure 8-2. Typical organization for search operations.



**Figure 8-3. Conduct of a search.**

(2) **Conducting the Search.** A search of a built-up area must be conducted with limited inconvenience to the populace. The search should inconvenience the populace enough for them to discourage insurgents and sympathizers from remaining in the locale but not enough to drive them to collaborate with the enemy as a result of the search. A large-scale search of a built-up area is a combined civil police and military operation. Such a search should be planned in detail and rehearsed while avoiding physical reconnaissance of the area just before the search. Aerial photographs can provide information needed about the terrain. In larger towns or cities, the local police might have detailed maps showing relative sizes and locations of buildings. As with any Army operation, mission analysis is critical. For success, the search plan must be simple and the search conducted swiftly. The search element is organized into teams. These teams can include personnel and special equipment for handling prisoners, interrogations, documentation (using a recorder with a camera), demolitions, PSYOP and civil affairs, mine detection, fires and effects, employment of scout dogs, and tunnel reconnaissance. Three basic methods are used to search the populated area.

(a) Assemble inhabitants in a central location if they appear to be hostile. This method provides the most control, simplifies a thorough search, denies insurgents an opportunity to conceal evidence, and allows for detailed interrogation. Depending on the objective of the search, a personnel search team may be necessary in this central location. This method has the disadvantage of taking the inhabitants away from their dwellings, thus encouraging looting which in turn engenders ill feelings. The security element is responsible for controlling the inhabitants. The search element may escort individuals back to their dwellings to be present during the search or may leave them in the central location.

(b) Restrict inhabitants to their homes. This prohibits movement of civilians, allows them to stay in their dwellings, and discourages looting. The security element must enforce this restriction. The disadvantages of this method are that it makes control and interrogation difficult and gives inhabitants time to conceal evidence in their homes.

(c) Control the heads of the households. The head of each household is told to remain in front of the house while everyone else in the house is brought to a central location. The security element controls the group at the central location and the heads of households and provides external security. During the search, the head of the household accompanies the search team through the house. Looting is reduced, and the head of the household sees that the search team steals nothing. This is the best method for controlling the populace during a search.

(3) **Searching a House.** The object of a house search is to look for controlled items and to screen residents to determine if any are suspected insurgents or sympathizers. A search party assigned to search an occupied building should consist of at least one local policeman, a protective escort for local security, and a female searcher. If inhabitants remain in the dwellings, the protective escort must isolate and secure the inhabitants during the search. Escort parties and transportation must be arranged before the search of a house. Forced entry may be necessary if a house is vacant or if an occupant refuses to allow searchers to enter. If the force searches a house containing property while its occupants are away, it should secure the house to prevent looting. Before US forces depart, the commander should arrange for the community to protect such houses until the occupants return.

d. **Other Considerations.** The reserve element is a mobile force positioned in a nearby area. Its mission is to help the search and security elements if they meet resistance beyond their ability to handle. The reserve element can replace or reinforce either of the other two elements if the need arises. Soldiers should treat any enemy material found, including propaganda signs and leaflets, as if it is booby-trapped until inspection proves it safe. Underground and underwater areas should be searched thoroughly. Any freshly excavated ground could be a hiding place. Soldiers can use mine detectors to locate metal objects underground and underwater. Reserve elements should maintain the same task organization as the cordon and search elements

e. **Aerial Search Operations.** Search units mounted in armed helicopters take full advantage of the mobility and firepower of these aircraft.

(1) Air mobile combat patrols conducting an aerial search reconnoiter an assigned area or route in search of enemy forces. When a patrol locates an enemy force, the patrol may engage it from the air or may land and engage it on the ground. This technique has little value in areas of dense vegetation or when a significant man-portable air defense threat is present.

(2) Air mobile combat patrols should be used only when sufficient intelligence is available to justify their use. Even then, ground operations should be used along with such patrols.

f. **Apprehended Insurgents.** Certain principles govern actions taken when insurgents desert or surrender voluntarily and indicate, at least in part, their attitudes and beliefs have changed. In this situation they are confined only for screening and processing. They are kept separate from prisoners who exhibit no change in attitude.

g. **Captured Insurgents.** Captured insurgents who retain their attitude of opposition are turned over to the host nation civil authorities.

### **8-37. ROADBLOCKS AND OTHER CHECKPOINTS**

Roadblocks and checkpoints are among the most visible and important actions performed during stability operations (Figure 8-4). Checkpoints in proximity of “zones of separation” offer a myriad of planning concerns. There is a high potential for junior leaders and soldiers to make decisions with international importance--in essence a number of “junior ambassadors.” Therefore, establishment and continual analysis of standing operating procedures is critical to ensuring equity and support. A related aspect of populace and resource control mentioned previously is the control of transportation. Individuals and vehicles may be stopped during movement to assist in individual accountability or capture of enemy personnel or to control the trafficking of restricted material. The ability to establish roadblocks and checkpoints is an important aspect of movement control and area denial. The fundamentals of searches, discussed previously, applies to roadblocks and checkpoints also. (FM 7-10 provides more information about roadblocks and checkpoints.)

a. Roadblocks and checkpoints help prevent smuggling operations and stop the movement of known or suspected insurgents. They should be manned by host-nation police (when applicable) in conjunction with UN monitors to stop vehicles and pedestrians and conduct searches as required by conditions. They must take care to maintain legitimacy by not targeting specific groups. Either host country or US Army combat forces defend these roadblocks and checkpoints from enemy attack. If police strength is insufficient for the number of positions required, the Army can operate them. Whenever US Army forces operate roadblocks and checkpoints, host country police or other forces should be present to conduct the actual stop and search. US forces should establish communications with other elements of the site but should also remain in contact with their own chain of command. The same principles apply to waterways as to landlines of communication.

b. Establish roadblocks in locations where approaching traffic cannot observe them until it is too late to withdraw and escape. When possible, roadblock locations must be periodically relocated in order to mitigate bypassing and targeting by enemy forces. Narrow defiles, tunnels, bridges, sharp curves, and other locations that channel traffic are the preferred sites. Constructed, nonexplosive obstacles slow traffic, restrict it to a single lane, and bring it to a halt. An area off the main road should be used to conduct a detailed search of suspect vehicles and people and to avoid unduly delaying innocent traffic. A small reserve using hasty field fortifications in nearby defended areas should provide immediate support to operating personnel in case of attack. A larger reserve, which serves a number of posts, should be capable of rapid reinforcement.

c. US forces should fill the reserve role in combined operations with host nation personnel. The reserve is vulnerable to being set up or ambushed, especially if an enemy has observed rehearsals. The enemy may hit multiple locations simultaneously to test responsiveness or to aid his future planning.

d. Outside of normal military concerns of planning, reconnaissance, security, and actions on the objective, units must have knowledge of civil authorities, factional boundaries, significant cultural sites, linguist use, and knowledge of the local populous

and geography. Further, it is imperative that leaders who are responsible for checkpoints appraise higher headquarters of problems and render specific recommendations for mission accomplishment.

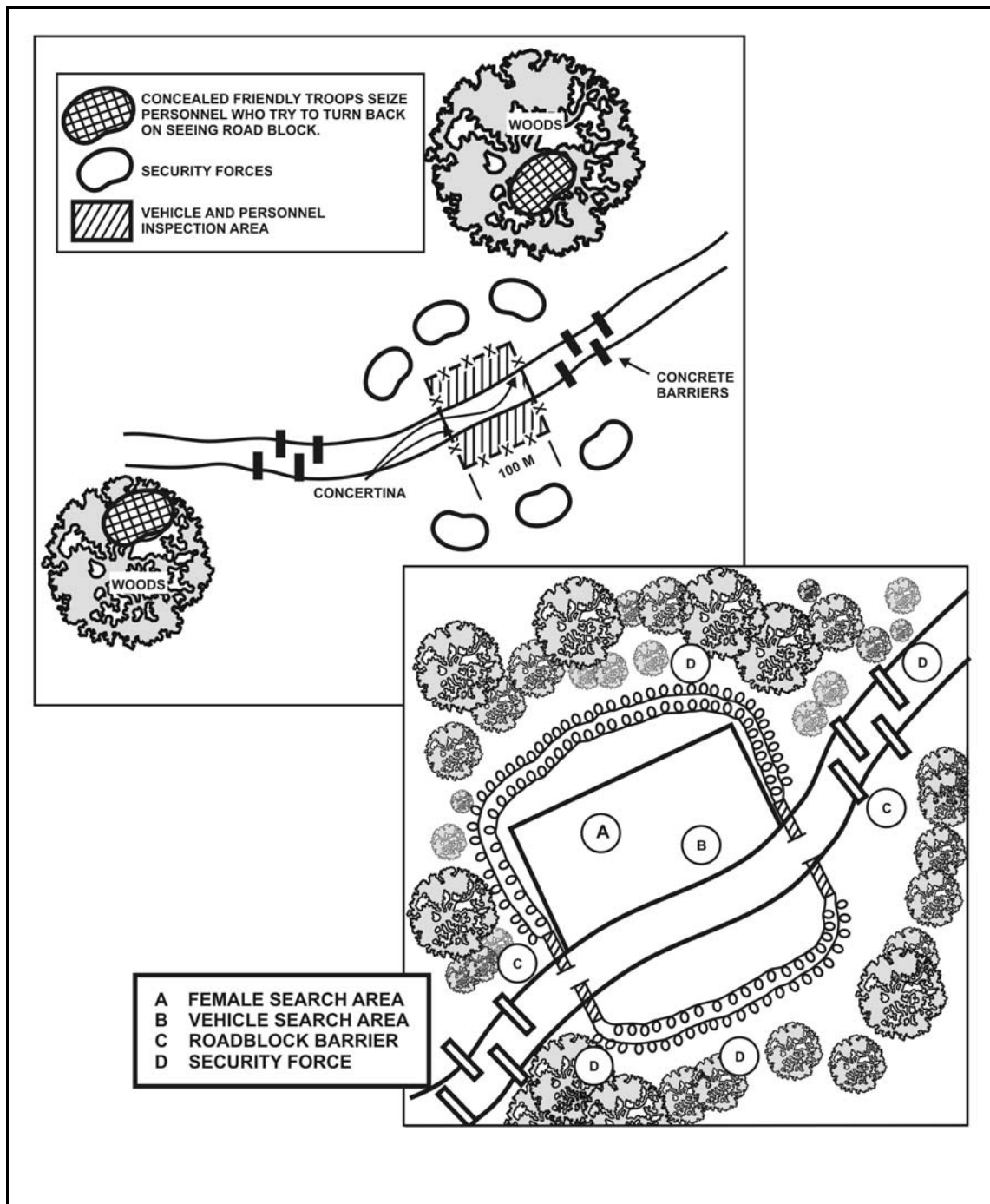


Figure 8-4. Physical layout of roadblock.



**8-38. REACT TO A CIVIL DISTURBANCE**

In order to prevent or mitigate a civil disturbance, units must remain flexible in order to change tactics as necessary. Units must use speed in deployment, arrest, apprehension, and reaction to change through proper positioning of forces. Effective use of combat multipliers such as PSYOP, civil affairs, host nation police, and linguists can prevent many incidents from happening or escalating to dangerous levels. A disciplined appearance of force is often more effective than using the force. The mnemonic device of IDMM (isolate, dominate, maintain, multidimensional-multiecheloned) can assist units in handling civil disturbances:

- Isolate the trouble spot in time and space from outside influence or interaction.
- Dominate the situation through an appropriate show of force and control of information
- Maintain situational understanding with aerial assets, NGOs, HUMINT, PSYOP, civil affairs, and linguists and disseminate information
- Multidimensional-multiecheloned actions are key; for example, use CA to negotiate and NGOs to remind parties of possible consequences.

**Section II. SUPPORT OPERATIONS**

Support operations involve Army forces providing essential supplies, capabilities, and services to help civil authorities deal with situations beyond their control. In most cases, Army forces focus on overcoming conditions created by natural or manmade disasters. Army forces may provide relief or assistance directly, but Army activities in support operations most often involve setting the conditions that facilitate the ability of civil authorities or NGOs to provide the required direct support to the affected population. Support operations missions vary by type and are further differentiated by the specific factors of METT-TC. Support operations usually require the TF to perform common tactical missions and tasks but also call on them to execute unique missions and tasks.

**8-39. TYPES OF SUPPORT OPERATIONS**

The types of support operations are domestic support operations (DSOs) and foreign humanitarian assistance (FHA) operations. DSOs and FHAs share four forms of operations which occur to varying degrees in both: relief operations, support to incidents involving chemical, biological, radiological, nuclear, and high-yield explosive consequence management (CBRNE-CM), support to civil law enforcement, and community assistance. The US Army conducts DSOs in the US and its territories, using active and reserve components. It conducts foreign humanitarian assistance operations abroad and under the direction of a combat commander. Since domestic emergencies can require Army forces to respond with multiple capabilities and services, they may conduct the four forms of support operations simultaneously during a given operation.

a. **Domestic Support Operations.** DSOs supplement the efforts and resources of state and local governments and NGOs within the United States. During DSOs, the US military always responds in support of another civilian agency. DSOs also include those activities and measures taken by DOD to foster mutual assistance and support between DOD and any civil government agency in planning or preparedness for, or in the application of resources for response to, the consequences of civil emergencies or attacks,

including national security emergencies or major disasters. A presidential declaration of an emergency or disaster area usually precedes a DSO.

(1) The US military provides domestic support primarily in accordance with a DOD directive for military assistance to civil authorities. The military assistance to civil authorities directive addresses responses to both natural and manmade disasters and includes military assistance with civil disturbances, counterdrug activities, counterterrorism activities, and law enforcement.

(2) In accordance with the Constitution, civilian government is responsible for preserving public order. However, the Constitution does allow the use of military forces to protect federal and civilian property and functions. The Posse Comitatus Act restricts the use of the military in federal status and prevents it from executing laws and performing civilian law enforcement functions within the US.

(3) DSOs focus on the condition of all types of natural and manmade properties with the goal of helping to protect and restore these properties, as requested. Typically, environmental operations are conducted in response to such events as forest and grassland fires, hazardous material releases, floods, and earthquakes.

(4) At the onset of DSOs that involve the provision of medical care, criteria for eligibility of care must be established and disseminated to all medical units and elements. A determination must also be made as to when this eligibility ends and when the patients once again become the responsibility of the local medical infrastructure. Further, a determination must be made as to what supplies and services are reimbursable and what government agency or organization is responsible for this reimbursement. For additional information on domestic support operations pertaining to disaster assistance, see FMs 100-19 and 8-42, and the Federal Response Plan for Public Law 93-288, as amended.

b. **Foreign Humanitarian Assistance.** US forces conduct FHA operations outside the borders of the US or its territories to relieve or reduce the results of natural or manmade disasters or other endemic conditions, such as human suffering, disease, or deprivation, that might present a serious threat to life or that can result in great damage to or loss of property.

(1) The US military typically supplements the host nation authorities in concert with other governmental agencies, nongovernmental organizations, private voluntary organizations, and unaffiliated individuals. The majority of foreign humanitarian assistance operations closely resemble domestic support operations. The distinction between the two is the legal restrictions applied to US forces inside the US and its territories. Posse Comitatus does not apply to US forces overseas.

(2) Foreign humanitarian assistance operations are limited in scope and duration. They focus exclusively on prompt aid to resolve an immediate crisis. Crises or disasters caused by hostile individuals or factions attacking its government are normally classified as stability rather than support operations. In environments where the situation is vague or hostile, support activities are considered a subset of a larger stability or offensive or defensive operation.

#### **8-40. THE ARMY'S ROLE IN SUPPORT OPERATIONS**

The Army is not specifically organized, trained, nor equipped for support operations. Instead, Army elements and forces, tailored for warfighting, are rapidly adapted to dominate a crisis or disaster situation. In support operations, Army forces apply decisive

military capabilities to set the conditions for the supported civil authorities to achieve success. Army forces have a functional chain of command, reliable communications, and well-trained, well-equipped forces that can operate and sustain themselves in an austere environment with organic assets.

a. **Rules of Engagement.** The ROE established for support operations must be consistent with training and equipment capabilities. For example, *shoot to wound* is not an effective instruction unless soldiers have been trained in this skill. When necessary, command guidance clarifies the ROE. While the rules must be tailored to the situation, TF commanders should observe that nothing in such rules negates their obligation to take all necessary and appropriate action in unit self-defense, allowing soldiers to protect themselves from deadly threats. The ROE rule out the use of some weapons and impose special limitations on the use of weapons. Examples include the requirements for warning shots, single shot engagements, and efforts to wound rather than kill. A TF deploying for support operations trains its soldiers to interpret and apply the ROE effectively. It is imperative for everyone to understand the ROE since small-unit leaders and individual soldiers must make ROE decisions promptly and independently.

b. **Multiple and Overlapping Activities.** In most situations, Army forces involved in support operations, both DSOs and FHA, execute a combination of multiple overlapping activities. Forces must conduct support operations with consistency and impartiality to encourage cooperation from indigenous forces and the population and to preserve the legitimacy of the overall effort. The actions of squads, platoons, or even individual soldiers take place under the scrutiny of many interested groups and can have disproportionate effects on mission success. Therefore, high levels of discipline, training, and a thorough understanding of mission outcome are necessary for effective support operations.

c. **Mission Training.** A sound foundation in combat mission training and in basic military skills and discipline underpins the TF's ability to perform support operations missions, but many of the key individual and collective skills differ and must be trained for deliberately. TFs use most of their regularly trained movement and security tasks in support operations missions, but they modify those tasks for the special conditions of their mission. They also train leaders and soldiers for unique tasks necessary to the certain types of operation that they are assigned.

d. **Operational Environment.** The mission, the terms governing the Army's presence in the AO, the character and attitude of the population, the military and civilian organizations cooperating with the TF, the physical and cultural environments, and a host of other factors combine to make each support operations mission unique. With the exception of specific actions undertaken in counterterrorism operations, support to counterdrug operations, and noncombatant evacuation operations, support missions tend to be decentralized and highly structured. A TF's activities consist in large part of directing the operations of their company teams and supporting units within a sector or AO in accordance with a detailed operations order.

## 8-41. FORMS OF SUPPORT OPERATIONS

Support operations may be independent actions or they may complement offensive, defensive, and stability operations. Most offensive, defensive, and stability operations

require some form of support operations before, during, and after execution. Support operations generally fall into four categories:

- Relief operations.
- Support to incidents involving CBRNE-CM.
- Support to civil law enforcement.
- Community assistance.

a. **Relief Operations.** In general, the actions performed during relief operations are identical in both domestic support operations and foreign humanitarian assistance operations. The actions can be characterized as either humanitarian relief, which focuses on the well-being of supported populations, or disaster relief, which focuses on recovery of critical infrastructure after a natural or manmade disaster. Relief operations accomplish one or more of the following:

- Save lives.
- Reduce suffering.
- Recover essential infrastructure.
- Improve quality of life.

(1) **Disaster Relief.** Disaster relief encompasses those actions taken to restore or recreate the minimum infrastructure to allow effective humanitarian relief and set the conditions for longer-term recovery. This includes establishing and maintaining the minimum safe working conditions plus security measures necessary to protect relief workers and the affected population from additional harm. Disaster relief may involve repairing or demolishing damaged structures; restoring or building bridges, roads, and airfields; and removing debris from critical routes and relief sites.

(2) **Humanitarian Relief.** Humanitarian relief focuses on life-saving measures to alleviate the immediate needs of a population in crisis. It often includes the provision of medical support, food, water, medicines, clothing, blankets, shelter, and heating or cooking fuel. In some cases, it involves transportation support to move affected people from a disaster area.

b. **Support to Incidents Involving Weapons of Mass Destruction.** Military operations assist civil authorities in protecting US territory, population, and infrastructure prior to an attack by supporting domestic preparedness and critical asset protection programs. If an attack occurs, military support responds to the consequences of the attack.

(1) **Domestic Preparedness.** The Army's role in facilitating domestic preparedness is to strengthen the existing expertise of civil authorities. This is done in the two primary areas of response and training. Response is the immediate reaction to an attack and training includes what happens after the attack.

(2) **Protection of Critical Assets.** The purpose of this program is to identify critical assets and to assure their integrity, availability, survivability, and capability to support vital Department of Defense (DOD) missions across the full spectrum of military operations. Critical assets include telecommunications, electric power, gas and oil, banking and finance, transportation, water, and emergency services. An attack on any of these assets may disrupt civilian commerce, government operations, and the military.

(3) **Response to WMD Incidents.** The initial response to use of WMD is primarily from local assets, but sustained Army participation may be required soon afterward. The Army's capabilities in this environment are--

- Detection.
- Triage treatment.
- Decontamination and medical care, including assessment.
- MEDEVAC.
- Hospitalization.
- Follow-up on victims of chemical and biological agents.

c. **Support to Civil Law Enforcement.** Support to domestic civil law enforcement generally involves activities related to counterterrorism, counterdrug operations, civil disturbance operations, or general support. Army support may involve providing resources, training, or direct support. Federal forces remain under the control of their military chain of command at all times while providing the support.

(1) **Support to Counterterrorism.** Unless authorized by the President (or a presidential decision directive), Army forces do not conduct domestic counterterrorism, but they may provide support to lead federal agencies during crisis and consequence management of a terrorist incident. They may provide assistance in the areas of transportation, equipment, training, and personnel. When terrorists pose an imminent threat to US territory, its people, or its critical assets, the US military may conduct support operations to counter these threats, using ground, air, space, special operations, or maritime forces. The Federal Bureau of Investigation (FBI) is responsible for crisis management in the US.

(2) **Support to Counterdrug Operations.** Army support to domestic counterdrug operations is very limited and usually only in a support role.

(3) **Civil Disturbance Operations.** The Army assists civil authorities in restoring law and order when local and state law enforcement agencies are unable to resolve a civil disturbance. Federal Army forces assist in restoring law and order when the magnitude of a disturbance exceeds the capabilities of local and state law enforcement agencies, including the National Guard. Army participation is to apply the minimum force necessary to restore order to the point where civilian authorities no longer require military assistance.

(4) **General Support.** The Army may also provide training, share information, and provide equipment and facilities to federal, state, and local civilian law enforcement agencies.

d. **Community Assistance.** Community assistance is a broad range of activities designed to strengthen the relationship between the Army and the American people. These projects should exercise individual soldier skills, encourage teamwork, challenge leader planning and coordination skills, and result in accomplishments that are measurable. Example activities include youth physical fitness programs, medical readiness programs, and antidrug programs.

## 8-42. PLANNING CONSIDERATIONS

The planning and execution of support operations are fundamentally similar to planning, preparing, executing, and assessing offensive, defensive, and stability operations. However, while each support operation is unique, the following four broad considerations can help forces develop mission-specific concepts and schemes for executing support operations.

### 8-43. CONSIDERATIONS FOR SUPPORT OPERATIONS

Whether they confront the complications of floods, storms, earthquakes, riots, disease, or other humanitarian crises, the battalion task force combines the usual strengths of the mounted and dismounted forces. Although it has limited numbers of medical and engineer elements, the battalion task force brings to the operation its outstanding abilities to organize and supervise operations, collect and distribute information, and communicate, as well as large numbers of highly disciplined and motivated soldiers. The following four broad imperatives that pertain to support operations help forces plan and execute support operations:

- Provide essential support to the largest number of people.
- Coordinate actions with other agencies.
- Establish measures of success.
- Transfer responsibility to civilian agencies as soon as possible.

a. **Provide Essential Support to the Largest Number of People.** Commanders must allocate finite resources to achieve the greatest good. Additionally, commanders require an accurate assessment of what needs to be done to employ military power effectively. In some cases, the TF can accomplish this task using warfighting reconnaissance capabilities and techniques. Commanders determine how and where to apply limited assets to benefit the most people in the most efficient way. They usually focus initial efforts on restoring vital services, which include food and water distribution, medical aid, power generation, search and rescue, and firefighting.

b. **Coordinate Actions with Other Agencies.** Domestic support operations are typically joint and interagency, and foreign humanitarian assistance operations are usually multinational as well. Unity of effort between the military and local authorities requires constant communication to ensure that tasks are conducted in the most efficient and effective way and resources are used wisely.

c. **Establish Measures of Effectiveness.** A critical aspect of mission handover is to have objective standards for measuring progress. These measures of effectiveness determine the degree to which an operation is accomplishing its established objectives. For example, a measure of effectiveness might be a decrease in the number of deaths caused by starvation. This is an indicator that food convoys are reaching the designated areas. These measures are situationally dependent and must be adjusted as the situation changes and guidance from higher is developed.

d. **Transfer Responsibility to Civilian Agencies as Soon as Possible.** Support operations planning must always include the follow-on actions of the civilian agencies and the host nation to restore conditions to normal. The following considerations determine handover feasibility:

- Condition of supported population and governments.
- Competing mission requirements.
- Specified and implied commitment levels of time, resources, and forces.
- Maturity of the support effort.

### 8-44. PLANNING PROCESS

The TF staff uses the standard Army planning process modified for use in a support environment.

- a. **Special Considerations.** The TF planning staff considers the following:

- Specialized support operations terminology in the mission and tasks assigned to the TF for purposes of mission analysis and course of action development.
- Command relationships, especially in multinational operations and in support to US civil authorities.
- Presence of, activities of, and the TF's relationship to nongovernmental organizations and private voluntary organizations in the AO.
- The political, economic, military, and environmental situation in the AO.
- Local customs, cultures, religions, ethnic groups, tribes, and factions.
- Force protection measures.
- ROE and other restrictions on operations.
- Terrain, weather, infrastructure, and conditions unique to the AO and the nature of the operation.
- Security operations.
- Availability or need for specialized units such as PA, CA, PSYOP, chemical defense, engineers, MPs, and others.

b. **Attached Elements.** TFs involved in support operations are normally reinforced with engineers and may also have troops attached. MPs, additional medics, and CA, PA, explosive ordnance disposal (EOD), counterintelligence (CI), and PSYOP teams often support TFs in support operations. Since these units are not commonly part of TFs in combat operations, the staff and company team commanders should learn the organizations, capabilities, limitations, and specific missions of attached organizations before employing them. In some cases, protecting those elements imposes additional loads on the maneuver company teams. Additionally, if attached units do not possess FBCB2, they need liaison teams or instrumented units of the TF to accompany them.

#### **8-45. COMMAND AND CONTROL**

Standard command and staff doctrine applies to support operations command and control. Orders, estimates, planning guidance, rehearsals, and backbriefs are all useful in directing support operations. The need for mutual understanding between all members of the command group is as great in support operations as in combat operations.

a. **Cooperation.** As in other cases, cooperation with foreign headquarters and other services or agencies imposes special requirements for training, coordination, and liaison.

b. **Command and Control.** The TF's command and control systems yield significant advantages in planning and conducting support operations. Operation of these systems depends on communications architecture provided by the brigade or by another higher level of command. Use of nontactical or other nonstandard communications is likely in a multinational operation or in support to civil authorities in the US. If this is the case, then TF commanders and staff leaders need training in operating these tools. In the early and concluding stages of an operation, the signal structure may permit only limited use of ABCS systems. The TF's plan for command and control must take this into account and provide for alternate means of communication or full reliance on tactical systems. Digitized connectivity to higher levels of command and to the information support structure multiplies the effectiveness of the TF and must be established as soon as possible.

c. **Liaison Teams.** Digitally equipped liaison teams can be extremely useful in providing a common view of the situation for headquarters attached to the TF. TFs must

staff their authorized liaison teams and identify their needs for additional teams as early as possible.

#### **8-46. MANEUVER**

In support operations, where area responsibilities, movements, and control of terrain are sensitive and hazards are sometimes widely scattered, the TF needs detailed information on its AO and commonly uses detailed control measures. TF leaders must clearly delineate and ensure soldiers throughout the TF understand routes, installations, hazards, the geographical responsibilities of company teams, boundaries, and other control measures. Leaders must also clearly communicate special control measures such as curfews, restrictions on movements, and prohibition of weapons to all concerned.

#### **8-47. INTELLIGENCE**

Intelligence collection and distribution systems facilitate support operations in the same general way they support other operations. The S2 uses the TF's organic collection assets to gather critical information on enemy or criminal forces and on the AO, according to the PIR established by the commander. The S2 then distributes intelligence to the TF as it is developed. The TF's ASAS remote workstation (ASAS-RWS) is an important means of maintaining a current view of the situation. In support operations conducted where combat is not taking place, there may be no enemy force present. Intelligence operations during some multinational operations will be proscribed or severely limited. In some cases, intelligence operations may be replaced with neutral, self-defensive information collection operations.

#### **8-48. INTELLIGENCE, SURVEILLANCE, AND RECONNAISSANCE**

A coordinated ISR effort is as critical to the TF's success in support operations as during combat operations. Information gathering is a constant process that is guided by CCIR and is normally embodied in an information collection plan. The commander may employ scouts, sensors, patrols, engineers, and liaison teams to achieve his ISR aims. The TF scouts play a special role in ISR, but every soldier and unit in the TF has some responsibility for observing and reporting. Therefore, the TF commander's PIR must be known throughout the TF and revised as often as necessary to assure that soldiers know what information is of greatest importance.

a. **Collection Assets.** The brigade reconnaissance troop, UAVs, and other military intelligence collectors can directly support the TF commander's PIR in some cases. In any case, the TF will receive useful information from those sources.

b. **Human Intelligence.** Human intelligence is of special importance in support operations IPB and ISR. In many cases, HUMINT specialists augment the brigade. The TF S2 normally receives some support from these teams and must be knowledgeable in their employment.

#### **8-49. FIRE SUPPORT**

Basic fire planning considerations for direct- and indirect-fire weapons remain valid. FS plans in support operations are integrated into tactical or force protection operations as the situation warrants. Accuracy and timeliness assume greater than normal importance in actions of support operations because of the importance of safeguarding the population



and preventing collateral damage. The advanced field artillery tactical data system (AFATDS) gives the commander and the fire support element (FSE) exceptionally clear and timely information on all aspects of FS. Fire planners in the digitized FSE must make special provisions for integrating fires from analog units, from fire support units of other armies, and from the naval and air components.

#### **8-50. MOBILITY AND SURVIVABILITY**

Mobility and survivability generally constitute major activities in support operations missions, especially at their outset. Force protection may make large initial demands on both combat and construction engineers during FHA missions. Mobility for the force and the population is also an issue early in many support operations as roads and bridges require repair, rubble clearing, and hazardous area marking or clearing. TFs can expect heavy commitments to securing engineer operations in the early stages of operations where enemy interference is possible. Even in mature support operations, engineer operations typically remain very active. Support operations are commonly supported with attached combat engineer units as well as construction engineers and contracted civilian engineers. Several engineer companies may support a TF conducting support operations; if so, the senior engineer company commander normally serves as the TF engineer.

#### **8-51. AIR DEFENSE**

TFs in support operations integrate air defense plans into tactical or force protection operations as the situation warrants. TFs must optimize passive defense and must nominate vulnerable sites in their AOs for ADA protection where threats exist.

#### **8-52. COMBAT SERVICE SUPPORT**

Combat service support for support operations usually requires substantial tailoring to adapt to unique mission requirements; logistical requirements vary considerably between types of support operations. Support operations commonly take place in areas where local resources and infrastructure are scarce, damaged, or fully devoted to the civilian population.

a. **CSS Support.** TFs should anticipate the support of their habitual forward support company as a minimum; the FSC may also be augmented with specialized elements for the operation.

b. **CSS Challenges.** The chief CSS challenges of support operations are to anticipate needs and to integrate nondigital units and sources into the support operation. Information needs include--

- Resources available in-theater.
- Status of critical supply items and repair jobs.
- Nature and condition of the infrastructure.
- Capabilities of general support CSS units.
- Mission tasks.
- Overall material readiness of the TF.

c. **Health Services Support.** In support operations, the TF will also deploy with its organic medical assets for support operations. In addition, the TF is augmented with a forward surgical team (FST) and an FSMT. The FSMT will not be available until after the first 96 hours of entry operations. Additional CHS assets may be task-organized to

support the TF mission. Support operations may include disaster relief and refugee operations. Humanitarian and civic assistance programs must be in compliance with Title 10, United States Code, Sections 401, 401(E),(5), and Section 2551. For additional information on selected sections of Title 10, US Code, see Appendix L of FM 8-42. Also, see FM 8-42 for HSS of disaster relief or refugee operations.

d. **Contracting.** In some cases, contracting can augment organic CSS. TFs may encounter contractor-provided services and supply operations in support operations environments. The S4 and commander must understand the terms and limitations of contractor support.

e. **Liaison with Civil Authorities.** Nonstandard supporting relationships and close coordination with civil authorities demand use of liaison teams to assure their greatest usefulness.

### 8-53. INFORMATION OPERATIONS

Information operations shape the perceptions of friendly, neutral, and hostile forces. The force commander employs PSYOP, CA, PA, and OPSEC as part of his information operation. The TF commander supports the higher commander's IO, carrying out tasks assigned to him and acting independently within the higher commander's intent and the constraints of his own resources. Because support operations are complex, usually decentralized, and often critical to the force's perceived legitimacy, continuity and consistency in IO are extremely important. The TF must present its position clearly to assure that the interested public, both in the US and in the AO, understand it. The commander must be aware of theater positions and interests and of the effects of events on the perceptions of his troops, his opponents, and the population in general. He must understand the positions of and information environment created by--

- Neutral parties.
- Warring or formerly warring factions.
- The population and its major segments.
- Other agencies working in the AO.
- Media.
- Information gathered by elements of the TF.

**NOTE:** In support operations conducted within the US, PSYOP personnel and assets may assist the IO plan but will not attempt to influence the population. They will assist in the dissemination of IO messages.

### 8-54. OTHER PLANNING CONSIDERATIONS

The following are additional planning considerations.

a. **Force Protection.** Force protection requires special consideration in support operations because threats may be different and because, in some cases, enemy or criminal forces may seek to kill, wound, or capture US soldiers for political purposes. TF leaders must identify threats to their units, make soldiers aware of the dangers, and create safeguards to protect them. Terrorist and guerrilla operations are of special concern. Commanders must also consider environmental threats such as diseases and climatic hazards; special dangers such as chemical contamination, unexploded ordnance, and weakened bridges and buildings; and criminal violence.

b. **Force Guidelines and Rules of Engagement.** Limitations on action from orders and ROE are the norm in support operations. Broad limitations may consist of restrictions on mounted patrolling at particular times and in specified areas, prohibitions on crossing political boundaries, and requirements to refrain from apprehending or limiting the movement of designated groups or individuals. They may originate in law, treaty, and settlement terms and in commanders' guidance. While ROE vary considerably among situations, they always allow soldiers to protect themselves from deadly threats.

c. **Legal Restrictions.** Legal restrictions apply to all Army operations including support operations. Legal restrictions relevant to support operations missions may include the Law of Land Warfare, the Uniform Code of Military Justice, treaty agreements, and federal, state, and foreign law. The brigade and higher staff judge advocates play important roles in planning and conducting these missions. In some cases, the JAG provides DS to the TF in the form of legal officers or enlisted legal assistants.

d. **Media Interest.** Media interest in support operations is normally high. Casualties and damage attract immediate attention and can affect the public's perception of the success and discipline of the force. A TF's soldiers and leaders must be sensitive to civilian concerns, media interests, and the way in which the political positions of factions within the AO affect their actions.

e. **Situational Understanding.** Superior situational understanding allows the TF commander to anticipate developments and act to prevent incidents, to protect his soldiers or the population, and to forestall greater loss or damage. Maintaining superior SU requires careful analysis of the TF's information needs and a mission-specific IPB supported by a collection plan that fully utilizes all the TF's organic and supporting assets. The analysis and control team at brigade level supports the TF commander's information needs and contributes to his SU by integrating and analyzing information collected from the brigade's various intelligence sources (HUMINT, SIGINT, UAVs, and so forth).

## 8-55. PATTERN OF OPERATIONS

While support operations vary greatly in every mission, the battalion task force can expect events to follow a broad pattern of response, recovery, and restoration.

a. **Response.** As part of a response, the TF enters the affected area, normally under brigade control, and makes contact with other relief organizations. Planning for the operation, staging command posts into the area, establishing security, deploying the TF, and initiating contacts with supported activities and other parts of the relief force occur during this phase of operations. The TF may make its chief contributions in this phase. Its soldiers are usually among the first relief forces to arrive. Its command and control structure gives it robust early ability to communicate and coordinate. Further, the TF's ability to reconnoiter and gather information makes it useful in the initial efforts of authorities to establish understanding and control of the area and to oversee critical actions. Typical requirements of the response period are--

- Search and rescue.
- High volume emergency medical treatment.
- Hazard identification.
- Initiation of information operations.
- Food and water distribution.

- Collection of displaced people in temporary shelter.
- Support to law enforcement agencies.
- Repair of power generation and distribution systems.
- Clearance and repair of roads, railways, and canals.
- Firefighting, NBC and hazardous industrial waste decontamination, and flood control.

b. **Recovery.** Once the TF operation is underway, recovery begins. With initial emergencies resolved and a working relationship between all parties in place, there should be steady progress in relieving the situation throughout this phase of operations. The TF is fully deployed in an AO or in an assigned task. Its work includes coordination with its parent headquarters, supported groups, and other relief forces and daily allocation of its own assets to recovery tasks. The TF's task organization is likely to change periodically as the need for particular services and support changes. Security, maintenance, effective employment of resources, and soldier support all need continuing attention. Medical officers should monitor and assist the commander in counteracting the psychological effects and preventing post traumatic stress problems associated with disaster relief work and exposure to human suffering. Unit leaders should conduct frequent after-action debriefings to allow their soldiers to talk about what they are doing and what they are seeing. Soldiers exhibiting signs of excessive stress, fatigue, or any uncharacteristic behaviors should be referred to mental health for additional stress debriefings. Typical tasks include--

- Continuing and modifying information operations.
- Resettling people from emergency shelters to their homes.
- Repairing infrastructure.
- Contracting to provide appropriate support (when feasible).
- Restoring power, water, communication, and sanitation services.
- Removing debris.
- Investigating crimes and supporting law enforcement agencies.
- Transferring authority and responsibility to civil authorities.
- Planning for redeployment.

c. **Restoration.** Restoration is the return of normalcy to the area. As civil authorities assume full control of remaining emergency operations and normal services, the TF transfers those responsibilities to replacement agencies and begins redeployment from the area. During restoration the commander should consider issues such as--

- Transfer of authority to civil agencies.
- Transition of command and control for agencies and units that remain in the area.
- Movement plans that support redeployment and continued recovery in the area.
- Staging of command and control out of the area.
- Accountability of property or transfer of property to the community if authorized.
- Force protection during movement.

## 8-56. SEQUENCE OF OPERATIONS

Generally, support operations follow the sequence of--

- Movement into the AO.
- Establishment of a base of operations.
- Maintenance of stability or support.
- Terminating operations.

In every part of the sequence, there are special considerations for digitized units initiating an operation or replacing another unit that has performed the mission before them.

a. **Movement into the area of operations.** Command and control considerations normally include using advance parties or liaison teams, establishing command posts, and sequencing the arrival of key leaders. TF commanders must prepare a complete plan for establishing control of the AO that includes a concept for phased installation of signal and C2 INFOSYS. Transfer of authority from the unit in place to the arriving unit and methodical, accountable handover of the AO is also of primary interest. Detailed rehearsals and mock drills held in preparation for this task are a regular part of preparatory training. Mission CCIR should guide staff specialists as they build databases and map displays to support the operation. The commander's PIR should determine the order in which critical information (for example, enemy dispositions, locations of hazards, and communities in greatest need of support) is assembled and distributed. Because they create superior information, the assets of the digitized TF generally facilitate faster, more secure performance of key tasks. For instance, digitized C2 INFOSYS simplify the processes of opening routes, repairing bridges, clearing obstacles, establishing security, and imposing movement control.

b. **Establishment of the Base of Operations.** Security, support, and continuous operations are the primary considerations during the establishment of a TF base of operations. The TF must maintain security continuously and may spend its first days of operation exclusively in securing its bases.

(1) **Occupation.** During the response phase, the TF moves in accordance with the controlling headquarters' order, employing advance parties and quartering parties as necessary. The TF may move to an assembly area in the affected area initially or may occupy its AO directly from the march. Establishing communications across the AO, refueling vehicles and recovering any inoperable equipment, establishing logistical facilities and medical aid stations, and reconnoitering the area are all early priorities for the TF. The TF must complete these preliminary tasks as quickly as possible in order to assume the mission promptly. In some cases, the TF must defer operations until it completes such tasks.

(2) **Battalion Task Force Focus.** The TF commander, the principal staff officers, and the company team commanders vigorously engage in making personal contact with supported groups, partners in the operation, and community representatives early in the response phase. Executive officers and staff assistants are, therefore, responsible for much of the internal activity of the TF during response.

(3) **Security.** Security of the TF is important during all phases of the operation but especially during arrival and organization. In addition to direct threats to the soldiers of the unit, the commander must also understand and provide for normal environmental hazards and special conditions caused by the emergency itself, such as disease, chemical residue, mines, and damaged infrastructure.

(4) **24-Hour Operation.** Organizing the command post for 24-hour operation in nontactical support operations also requires early attention. A detailed SOP, complete operations maps, and special provisions for communications, inspections, reporting, and adjusting security levels are necessities. Establishing a high standard for operations from the outset is key both because of the general sensitivity of support operations and because of the TF's special vulnerabilities in its first days of the mission.

(5) **Equipment Substitution.** In some cases, high-mobility, multi-purpose wheeled vehicles (HMMWVs) or other light wheeled equipment replaces the heavy equipment of the TF to facilitate movement, limit the damages to infrastructure, or present a less threatening appearance. In the case of such substitution, driver and maintenance training is necessary well before the TF assumes the mission. The TF may have to modify CSS to support the new fleet. If the TF replaces an analog unit or a different size organization, it may have to modify base camp layouts or even reduce the number of operating bases.

c. **Maintenance of Support Operations.** Steady-state mission performance differs in each instance. Support operations have a varied duration and characteristically orient on relieving crises in an area or population.

(1) **Protect the Force.** Force protection remains a priority throughout support operations, and threats are constantly reassessed. The TF must maintain consistency in dealing with the population and in enforcing policy over time. Likewise, the commander must ensure maintenance of troop information and discipline throughout the operation. The TF should perform internal reviews and after-action reviews (AARs) and seek outside inspection of critical functions to assure that its standards of security and performance remain high throughout the full course of the mission. Involving soldiers in AARs and circulating lessons learned throughout the TF are means of preventing complacency, boredom, and lapses in security.

(2) **Readiness.** During some support operations, the TF must retain its readiness to transition to conventional operations. It must maintain and rehearse reaction forces and provisions for increased levels of security in base camps, at observation posts, and in patrols to assure readiness. Commanders should continually review their operations to detect patterns, vulnerabilities, or complacency that an opponent might exploit.

d. **Terminating Operations.** Support operations end in different ways. Crises may be resolved, or a continuing support operation may be handed over to a replacement unit, a multinational force, a police force, or civil authorities. Missions of short duration or narrow scope (such as support to civil authorities) may end with the completion of the assigned task.

(1) **With Transfer of Control.** Transferring control of an AO or an operation to a follow-on force requires detailed coordination to assure that all relevant information passes to the commander or the other authority assuming responsibility. This procedure entails transfer of databases, maps, inventories, records, and equipment. In cases where the TF uses unique files and systems, staff leaders and commanders may have to go through extensive coordination to assure that their successors possess and understand all critical information.

(2) **Without Transfer of Control.** If the TF leaves the AO without replacement, it must plan for an orderly, secure departure that protects the force throughout the operation and sustains sufficient C2 INFOSYS in the AO until withdrawal is complete. In

redeployment, force protection and accountability for soldiers, systems, and materiel are always of concern.

### **8-57. TRANSITION TO COMBAT**

In some support operations (typically those that take place in an active combat theater), the TF commander must remain prepared to defend himself or to attack forces that threaten his command. This applies differently in each operation. It may mean maintaining a reserve or a quick reaction force within the TF. It may even compel the TF to dispose its forces in ways that allow immediate transition from support operations to combat. Additionally, the TF must address the considerations of transitioning to less restrictive ROE.

a. **Mission Focus.** Because of their size and resources, company teams should be assigned a single mission. If they are performing support operations tasks, they are normally capable of only self-defense and very limited offensive actions. To improve their ability to transition to combat, the TF commander may designate a company team as the reserve, position a company team to defend or secure the AO, or discontinue most support operations tasks and position all his company teams in a tactical assembly area, ready to respond to anticipated enemy action.

b. **Reaction Time.** States of increased alert or readiness can reduce reaction time for a transition from support operations to combat. Contingency plans covering the most likely combat actions are necessary in preparing for this transition. Rehearsals assure better reaction and deter enemies from overt action.

c. **Readiness Preservation.** Passive measures that preserve readiness include dispersion of forces, operation of the early warning systems, and force protection measures affecting arming and moving of troops. Active measures include positioning of field artillery, air defense artillery, engineer, tank, and infantry companies, along with the preparation of contingency plans.

d. **Maintenance of COP.** The TF's ability to maintain current information; distribute information, orders, and graphics; coordinate fires, aviation, and close air support; direct CSS precisely; and gain information dominance facilitate its transition from support operations to combat. By maintaining current contingency plans, alert staffs and commanders, and well-trained and informed soldiers, the TF can meet combat challenges ably on short notice.

### **8-58. TRAINING CONSIDERATIONS**

The battalion task force must conduct support operations with consistency and impartiality to encourage cooperation from indigenous forces and the population and to preserve the legitimacy of the overall effort. The actions of squads, platoons, or even individual soldiers take place under the scrutiny of many interested groups and can have disproportionate effects on mission success. Therefore, high levels of discipline and training and a thorough understanding of mission outcome are necessary for effective support operations.

### **8-59. TRAINING FOR SUPPORT OPERATIONS**

A sound foundation in combat mission training and in basic military skills and discipline underpins the TF's ability to perform support operations missions. However, many of the

key individual and collective skills differ and must be trained for deliberately. TFs use most of their regularly trained movement and security tasks in support operations missions, but they modify these tasks for the special conditions of their specific mission. They also train leaders and soldiers for unique tasks necessary for a certain type of operation.

a. **Mission-Essential Task List.** Support operations tasks are not usually included in a TF's METL unless the TF has been specifically assigned a support operations mission or its commander has determined that the likelihood of such assignment warrants dedicated training. Training for support operations, therefore, begins with the perception or assignment of a mission. Notification for support operations employment normally requires rapid reaction to an emergency but sometimes may allow for deliberate preparation.

b. **Deliberate Preparation.** In the case of deliberate preparation, a commander can anticipate a minimum of one to two weeks of mission training. This training may include a structured mission rehearsal exercise, in-country orientation, and leader reconnaissance of the AO. Classes on the AO and the mission, training in the ROE and in use of special equipment, and familiarization with the other organizations present in the area may be part of this training. Reviews of Army lessons learned and preparation of families and the rear detachment also accompany this training.

c. **Immediate Response.** In the event of an emergency or other time-constrained event, the commander will need to respond immediately to mission requirements. In cases such as Hurricane Andrew and the Rwandan relief mission, commanders relied on standing operating procedures, general military skills, and the discipline of their troops. Conditions vary from case to case in this kind of reaction, but commanders can generally draw on Army lessons learned, general purpose TTPs, and maps prepared for training and intelligence from the projected AO to identify the most critical training requirements. The TF must address these in order of priority as time allows. Platoon and squad leaders can teach soldier skills and individual readiness training during deployment. Every operation differs in its details. Techniques that are effective in one theater are not necessarily effective elsewhere. Situational factors, from cultural practices to geography and from coalition make-up to ROE, represent substantial differences that training programs must take into account.

d. **Support Operations Task Organizations.** Many support operations modify headquarters and unit organizations. New staff positions may be added to the TF (CA, PSYOP, and PA are common). Unfamiliar organizations may be added to the task organization and the company teams, and platoons of the TF may be re-equipped and partially reorganized to meet mission requirements or to conform to mission requirements. In such cases, conducting staff drills, learning to operate new equipment, and practicing operations in new unit configurations must figure into TF and company team training plans.

## **8-60. DOMESTIC SUPPORT OPERATIONS- OR FOREIGN HUMANITARIAN ASSISTANCE -SPECIFIC TRAINING**

Training for support operations centers on assisting distressed populations and on responding to emergencies. Training for DSO and FHA operations routinely requires



cooperation with civil authorities and normally involves operating under special legal restrictions. DSO and FHA training may address--

- Orienting troops and leaders on legal restrictions and requirements.
- Preparing troops and leaders for hazards in the AO.
- Protecting humanitarian relief efforts.
- Organizing and conducting convoys with civilians and civilian vehicles.
- Supporting CA and PA operations.
- Organizing and securing relief centers.
- Assisting in logistical support and construction engineer operations.
- Supporting the coordination of nonmilitary organizations.
- Familiarizing troops with mission-specific tasks such as firefighting, flood control, hazardous material clean-up, riot control, protection of endangered groups or individuals, assistance to civilian law enforcement officials, and resettlement actions.

#### **8-61. ADDITIONAL REQUIREMENTS**

Almost all support operations missions also require--

- Orienting leaders and soldiers to the mission.
- Familiarizing troops with the area and cultures.
- Adapting standard tactical practices to the conditions of the mission.
- Adapting CS and CSS operations to the requirements of the mission.
- Understanding and applying ROE.
- Providing for force protection.
- Conducting effective media relations.
- Collecting information.

---

## CHAPTER 9

# COMBAT SUPPORT OPERATIONS

*The commander of a TF uses combat support elements as combat multipliers to enhance the combat power of his maneuver company teams. The addition of enablers to command, control, communications, and computer (C4) systems enhances the commander's ability to integrate these assets into the TF's scheme of maneuver. CS elements use enhanced information systems that provide increased situational understanding to stay abreast of the tactical situation and assist the commander in applying superior combat power at the decisive point on the battlefield.*

*This chapter describes the capabilities and limitations of digitized CS elements that support the digitized TF. The TF commander is responsible for the integration and synchronization of all available CS with available combat assets to accomplish his assigned mission. Digitization of maneuver and CS units affects the way in which the commander decides to employ his CS assets. These considerations ultimately dictate the relationships and responsibilities of attached CS assets.*

### Section I. FIRE SUPPORT

Fire support is the collective and coordinated use of indirect fire weapons, armed aircraft, and other lethal and nonlethal means in support of the commander's scheme of maneuver. In the past, the commander employed these means to suppress, neutralize, or destroy enemy targets or assets. In the more modern concept of shaping with fires, the focus is on the accomplishment of essential fire support tasks. In other words, where are the critical places on the battlefield that the commander wants to influence the battle with focused fires? Each essential fire support task is directly related to maneuver purpose and has a specific purpose and an end state that relates in time and space to an enemy formation or function. Digital systems have the potential to enhance greatly the TF's ability to focus fires, but they do not increase the lethality of munitions or the amount of munitions available to the commander. They do, however, provide the commander with improved situational understanding that enhances his ability to exploit his battl space rapidly with both lethal and nonlethal fires.

#### 9-1. FIRES

Fires refer to the application of collective firepower, coordinated and delivered by ground, sea, and aerial platforms in an integrated and synchronized manner. The term includes all line-of-sight and non-line-of-sight systems delivering lethal or nonlethal fires and applies to the full spectrum of military operations.

a. The Army must be dominant across the whole spectrum of conflict. It must always be prepared to fight at the high end of that spectrum but is equally likely to conduct operations in mid- to low-intensity conflicts. Thus, forces that provide fires must be able to operate and coordinate throughout the full spectrum of domains (space, information, air, sea, and land). Fires must focus on the concentration of effects and not on the concentration of forces.

b. Fires tasks have not changed. Their first priority is to support forces in contact. Fire support organizations and units must still help shape the battlespace, provide force protection, and set conditions for the ground maneuver forces they support. Artillery units must also be prepared to provide fires in close support of a maneuver unit as it closes with and completes the destruction or defeat of an enemy force. Modern weaponry, space exploitation, real-time knowledge, speed, and munitions now allow for widely dispersed and noncontiguous forces conducting simultaneous decisive operations throughout the entire maneuver unit’s area of operations.

**9-2. FIRE SUPPORT ORGANIZATIONS**

The fire support organizations found in TFs and company teams are shown in Tables 9-1 and 9-2. Every maneuver task force has a fire support element that is attached to the task force during combat operations. The FSE consists of field artillerymen who are specialists in working with all of the components of the FS system. These artillerymen also coordinate and integrate the functioning of the command, control, communications, computers, and intelligence (C4I) system; target acquisition (TA) systems; and FS means as they relate to the FA system.

a. The task force FSO supervises FS activities. These include planning, coordinating, and integrating FS operations, to include air, naval, and IO support. FSEs are organized to facilitate the coordination and execution of the FS system.

b. The FSE is designed to help the task force commander and staff integrate FS into all plans. The major functions of the FSE are to--

- Plan, control, and synchronize all lethal and nonlethal FS.
- Establish priorities and allocate available FS resources to support the TF.
- Participate in and supervise the routine activity and coordination of the targeting process within the task force main CP.
- Coordinate with the A2C2 element regarding artillery firing unit locations, changes to FSCMs, and airspace coordination measures (ACMs).
- Coordinate air support through the TACP.
- Coordinate suppression of enemy air defense (SEAD) or joint SEAD (J-SEAD) operations (or both).
- Coordinate combat aviation employment with FS operations.

TASK FORCE FIRE SUPPORT ELEMENT		
TITLE	RANK	NUMBER
Fire Support Officer	CPT	1
Fire Support Officer (Plans)	1LT	1
Fire Support Sergeant	SFC	1
Fire Support Sergeant	SSG	1
Fire Support Sergeant	SGT	1
Fire Support Specialist	SPC	1

**Table 9-1. Task force fire support element.**

COMPANY TEAM FIRE SUPPORT TEAM (FIST)		
TITLE	RANK	NUMBER
Fire Support Officer	1LT	1
Fire Support Sergeant	SSG	1
Fire Support Specialist	SPC	1
Fire Support Specialist	PFC	1

**Table 9-2. Company team fire support team.**

### 9-3. FIRE SUPPORT PLANNING AND COORDINATION

Fire support planning and coordination ensure that all available fire support is synchronized in accordance with the commander's concept of operations. The key to effective integration of fire support is the thorough inclusion of fire support in the planning process and a vigorous execution of the plan supported by an aggressive coordination effort.

a. **Fire Support Planning.** Chapter 3 contains a detailed discussion of the planning and military decision-making process as it applies to the task force as a whole. In this section, the primary focus is a detailed discussion of the fire support planning process. Fire support planning is the process of analyzing, allocating, and scheduling FS. The goal of FS planning is to integrate FS effectively into the fight to optimize combat power. It is performed concurrently with the MDMP. Effective FS planning places the right elements of the FS system in the right place at the right time in accordance with the commander's intent.

(1) The following basic principles of FS planning apply:

- Plan early and continuously.
- Follow the commander's targeting guidance.
- Exploit all available targeting assets.
- Consider the use of all available fire support means, both lethal and nonlethal.
- Use the lowest echelon capable of furnishing effective support.
- Use the most effective FS means.
- Furnish the type of FS requested.
- Avoid unnecessary duplication.
- Consider airspace coordination.
- Provide adequate fire support.
- Provide rapid and effective coordination.
- Remain flexible.
- Provide for the safeguarding and survivability of friendly forces and installations.

(2) The effectiveness of FS planning and the FS system depends on the successful performance of the four basic tasks: support forces in contact, support the concept of operations, synchronize FS, and sustain FS.

(a) *Support Forces in Contact.* Supporting forces in contact includes the allocation of weapons systems and sorties to subordinate elements that actually engage the enemy. Supporting forces in contact usually means providing responsive FS that protects and ensures freedom of maneuver to forces in contact with the enemy.

(b) *Support the Concept of Operations*. Supporting the concept of operations means providing FS for contingencies that relate to the commander's concept of the operation. FS assets must be identified and marshaled for execution at the right time and place. The brigade commander must allocate enough firepower to the task force commander so that he can influence the battle as necessary.

(c) *Synchronize Fire Support*. FS is synchronized through FS coordination, beginning with the brigade commander's estimate and concept of the operation. The task force FSO assists the task force commander in integrating all FS with the appropriate battlefield systems. These systems include intelligence, maneuver, FS, mobility and survivability, air defense, combat service support, and battle command (an expansion of command and control made possible by changes in the scope, intensity, and tempo of current and future operations).

(d) *Sustain Fire Support*. Combat sustainment includes all the CSS activities necessary to support battles, engagements, and related actions. A task force can realize the full combat potential of its forces and achieve synchronization in its operations only when combat sustainment is planned, coordinated, and executed efficiently. Planners must formulate tactical plans to reflect logistics limitations and exploit logistics capabilities.

b. **Force Responsibilities**. The brigade plays a vital role in task force fire support planning and execution. The brigade is the "provider" of indirect fires and through EFST ensures the nesting of fires.

(1) **Brigade**. The brigade develops a synchronized brigade scheme of maneuver and brigade concept of fires and translates that concept into a scheme of fires by assigning fire support tasks and allocating assets and effects to subordinates. As part of the concept of fires, it is the brigade's responsibility to set conditions for and provide indirect fires to the task force for the close or direct firefight. Fires in support of the task force close fight are provided for a specific period of time or a specific purpose. The brigade must clearly specify priority of fires and through ESFT will provide optional fires for the TF. Refinements to the brigade scheme of fires from subordinate units will be integrated via ESFT. Finally, the brigade integrates the movement of artillery units with the scheme of maneuver. (See FM 3-90.3, Chapter 9, for a detailed discussion of fire support planning at the brigade level). The brigade's role in fire support planning includes the following tasks:

- Synchronize the brigade concept of fires with brigade maneuver.
- Set conditions for the task force close fight.
- Provide force protection to the task force through both a proactive and reactive counterfire fight.
- Develop a brigade scheme of fires and assign tasks to subordinates.
- Provide fires for the task force close fight.
- Integrate refinements from subordinates.
- Integrate and synchronize the movement of artillery units with the scheme of maneuver.

(2) **Task Force**. The brigade allocates fire support to TFs IAW the plan. Therefore, the task force must clearly understand both the brigade concept of fires (and how it is synchronized to support the brigade scheme of maneuver) and the task force's role in the execution of its portion of the brigade scheme of fires. Understanding these things, the

task force must develop its own concept of fires. This concept normally involves assigned tasks from the brigade scheme of fires and targets to support the task force close fight. This may require only the refinement of a brigade target or may require the task force to submit new targets to support the task force commander's scheme of maneuver. Additionally, the task force must plan the synchronization of mortar fires with the scheme of maneuver, integrate the mortars into the scheme of fires, and synchronize their movement with the scheme of maneuver. The task force develops a scheme of fires to support both those tasks assigned by brigade and those targets developed by the task force. It then issues the fire support plan to its subordinates and incorporates bottom-up refinement to support the company team commanders' schemes of maneuver. Finally, the task force forwards its concept of fires and target refinements to brigade and ensures the plan is clearly understood through rehearsals. The task force's role in fire support planning includes the following:

- Understand the integration of the brigade scheme of fires and maneuver.
- Understand the task force's role in the brigade scheme of fires and maneuver.
- Execute the TF's portion of the brigade scheme of fires.
- Develop a task force concept and scheme of fires.
- Integrate and refine brigade targets for the close fight.
- Plan for the synchronization of the task force mortars with the scheme of fires and their movement with the scheme of maneuver.
- Incorporate bottom-up refinement from the company teams.
- Forward the task force concept of fires and target refinements to brigade.
- Conduct rehearsals.

(3) **Task Force Commander.** The key role of the task force commander in indirect fire planning is the synchronization of fires with maneuver. Fires and maneuver must be thought of together. Commanders must first decide precisely what they want their fires to accomplish. If the commander thinks maneuver first and then tries to add fires later, he will have difficulty. Once he has decided what he wants fires to accomplish, the commander must take an active role in the development of the task force concept of fire support. He must clearly articulate to the staff, not just the fire support officer, the sequenced essential fire support tasks in terms of desired effects for each target, the purpose of each target as it relates to the scheme of maneuver, the method he would like to use to achieve the desired effects, and the end state he wants for each target. The task force commander must also ensure that mortar fires are clearly synchronized with the scheme of maneuver and that the concept of fires and their movement is synchronized with maneuver. Once the task force scheme of fires is finalized, it is essential that the task force commander clearly articulate to the brigade commander and brigade staff the importance of those fires to the task force scheme of maneuver and the impact on mission success if those fires are not received. In most cases, if a task force essential fire support task is not also included as a brigade essential fire support task, the likelihood of getting the target fired by artillery or CAS is greatly diminished.

(4) **Imperatives.** The FS planning process has four imperatives.

(a) FS planning must be a part of the MDMP and mirror the steps of the existing planning process.

(b) FS planning must truly integrate the targeting process and its functions of decide, detect, deliver, and assess.

(c) FS planning must support and be integrated with the R&S plan. The ISR plan is a key link between the MDMP, FS planning, and targeting. The ISR plan links acquisition assets to finding specific enemy formations or required information to answer the CCIR.

(d) The result of the FS planning process is an effective, integrated, and executable plan:

- An effective plan clearly defines and focuses on achieving the effects required against the identified HPTs.
- An integrated plan provides the focus and timing for acquisition and attack systems to achieve a unified effect on HPTs.
- An executable plan ties detect and deliver assets to the HPTs and includes assessment of effects achieved.

#### 9-4. ESSENTIAL FIRE SUPPORT TASKS

A commander may assign fire tasks to subordinate units, request they be performed by higher and adjacent units or other combined or joint forces, or plan for his own command group to execute them. Fires can accomplish essential fire support tasks during any phase of the operation. An essential fire support task can, but does not necessarily, equate to a target, group, or series. For example, an essential fire support task may be the activation of a critical friendly zone for a weapons-locating radar. The establishment of essential fire support tasks does not equate to developing a task or target for each phase of the operation. To develop essential fire support tasks that mass effects at the decisive point(s), the commander and FSO must first visualize the fight. The commander and FSO can then state what the clearly defined, decisive, and obtainable objective is for fires. This objective should center on the desired effects upon an enemy formation or function (for example, destroy a company-size element at the obstacle). These objectives drive not only the delivery of fires, but also all the other aspects of fighting with fires to include the positioning of sensors and delivery assets. These objectives become the essential fire support tasks for the operation.

a. **Definition of Essential Fire Support Tasks.** An essential fire support task is a task FS must accomplish to support a combined arms operation. Failure to achieve an EFST may require the commander to alter his tactical or operational plan. A fully developed EFST has a task, purpose, method, and effects (Table 9-3, page 9-8). The task describes what targeting effect fires must achieve on an enemy formation's function or capability. The purpose describes how the task contributes to maneuver. The method describes how the task will be accomplished by assigning responsibility to sensors or units and delivery assets and providing amplifying information or restrictions. Effects quantify successful accomplishment of the task. Essential fire support tasks can be placed into one of five categories:

(1) **Close Support Fires.** These lethal or non-lethal fires support the maneuver of and protect ground forces in contact from attack by mounted and dismounted platforms. Close support fires are grouped into three types: obstacle breach, obstacle protection, and force protection.

(2) **Suppression of Enemy Air Defense.** These lethal or nonlethal fires support the maneuver of and protect aerial forces in contact from attack by mounted or dismounted platforms.

(3) **Fires to Support Information Operation.** These lethal or nonlethal fires attack the enemy's ability to make decisions and enhance the friendly commander's ability to gain information. Fires to support the information operation are grouped into two types: reconnaissance and counterreconnaissance.

(4) **Counterfire.** These lethal or nonlethal fires attack the enemy's capability to conduct non-line-of-sight fires.

(5) **Strike.** These lethal fires attack an enemy force's ability to maneuver, protect and sustain, or deliver fires by the physical destruction of air, mounted, and dismounted systems. Strike fires attack a specific enemy force or function and restrict the enemy commander's ability to bring it into the fight. These fires are grouped into three types: fixed, stationary, or moving targets.

b. **Effects.** Inherent to the purpose of an essential fire support task is the final effects of that task on the enemy. The effects statement is the most important aspect of the essential fire support task because the commander's guidance and the planning process revolve around the desired effect upon the enemy--not friendly actions. Targeting objectives provide a method for describing, in a measurable and relevant standard, the successful accomplishment of an essential fire support task. The objectives of targeting are to disrupt, divert, delay, limit, defeat, or destroy those enemy capabilities that could interfere with the achievement of friendly objectives. These should not be confused with attack criteria (harass, suppress, neutralize, or destroy) that are attack criteria used to determine the degree or duration of effects on a target. Targeting objectives refer to the commander's attack guidance and the desired effects of target attack on the enemy.

(1) When developing attack guidance and preparing to build an AFATDS database and the supporting targeting objectives, commanders must specify the end state or effects required in terms of time and space. For example, when the commander wants a force delayed, he must specify what force the fires will delay, where, and for how long. Commanders determine what effects they require to support the purpose of the essential fire support task. For example, if close support fires on a friendly obstacle will delay the enemy and allow a reserve to reposition, the commander must determine how long fires must delay the enemy at the obstacle. The attack guidance must be clearly defined. Neutralize and suppress are attack criteria and may also be considered when setting attack criteria in AFATDS.

(2) The following are specific definitions for each of the targeting objectives:

(a) **Disrupt.** The objective of "disrupt" is to break apart, disturb, or interrupt an enemy function. For example, the commander may want to disrupt the enemy's ability to counterattack. The attack guidance matrix (AGM) may direct the suppression, neutralization, or destruction of specific targets essential to the enemy's counterattack capability.

(b) **Divert.** The objective here is to force an enemy to alter a particular course of action once he is already in his execution phase.

(c) **Delay.** Delay slows the arrival of a unit on the battlefield.

(d) **Limit.** This objective restricts the enemy's capability to pursue a particular course of action.

(e) **Defeat.** This objective prevents the enemy from accomplishing a course of action or function.



(f) *Destroy*. This objective prevents the enemy from accomplishing any course of action or function. This term has a variety of joint definitions that are service-particular. Ultimately, the force commander must be fully aware of the variety of service and battlefield functional area definitions (for example, artillery destruction is 30 percent while Army aviation destruction is 70 percent).

(3) Development of essential fire support tasks are the key to helping the commander maintain a focus of fires expressed in clear, measurable terms.

<b>TASK</b>	Describes the objectives that fires must achieve against a specific enemy formation or capability (objective, formation, and function). <b>Objective:</b> Disrupt, delay, limit, or destroy. <b>Formation:</b> A specific element or subelement of the enemy. Can be a specific vehicle type or target type. <b>Function:</b> A capability of the formation that is needed for it to achieve its primary task and purpose.
<b>PURPOSE</b>	Describes the maneuver or operational purpose for the task. This should identify as specifically as possible the maneuver formation that will leverage the targeting effect and describe in space and time what the effect will accomplish.
<b>METHOD</b>	Describes how the task and purpose will be achieved. It ties the detect function with the deliver function in time and space and describes how to achieve the task (priority, allocation, and restrictions). <b>Priority:</b> Details the HOW of the EFST. It can assign a priority of fires, observers, or other acquisition means. <b>Allocation:</b> Describes the allocation of FS assets to accomplish the mission. <b>Restrictions:</b> Outlines any limitations or restrictions that may affect the accomplishment of the mission.
<b>EFFECTS</b>	Attempts to quantify the successful accomplishment of the task. Provides the basis for the assess function and the decision to reattack or not.

**Table 9-3. Essential fire support tasks.**

### 9-5. SCHEME OF FIRES

The scheme of fires is a supporting element of the concept of operations and articulates the focus of fires. The scheme of fires must describe what fires must do (EFSTs) in order to achieve the commander's intent. In other words, the scheme of fires describes, in sequential order and detail, where the commander intends to influence or win the battle with fires. It is the concept of fires and explains what essential support tasks must be accomplished to support the scheme of maneuver.

a. The scheme of fires must include the purpose as well as the who, what, when, and where for each task. The FSO develops the “how” during the tactical planning process and details it in the remainder of the plan. The scheme of fires must also identify all essential fire support tasks. They provide the purpose, method, and end state that each fires task must accomplish.

b. Essential fire support tasks become the focal point of fires. The scheme of fires further refines the focus of top-down fire planning by concentrating on the essential tasks that fires must perform. It provides the purpose, objective, method, and effects for those tasks in clear, measurable, and understandable terms.

### 9-6. QUICK FIRE PLANNING

The purpose of quick fire planning is to prepare and execute FS quickly in anticipation of an impending operation. The task force FSO must ensure that the DS battalion S3, FDC,

mortar platoon, task force staff, and company team commanders and FISTs understand the quick fire plan and how it is used.

a. **Quick Fire Planning Techniques.** Quick fire planning techniques constitute an informal fire plan. Quick fire planning differs from deliberate fire planning in that a bottom-up process is used rather than a top-down process. In the quick fire plan, the FSO is responsible for--

- Identifying targets in the target list to be engaged.
- Allocating all FS assets available to engage the targets in the plan.
- Preparing the schedule of fires.
- Disseminating the schedule to all appropriate FS agencies for execution.

b. **Quick Fire Planning Sequence.** There are six steps in the quick fire planning sequence.

(1) **Operation Order.** In receiving the OPORD, the FSO obtains the following decisions from the commander:

- Targets to be engaged.
- Desired effects on targets.
- Order and timing of target engagement.
- Duration of fires.
- H-hour.
- Priority of fires.
- Priority for targeting.
- Priority for execution.
- Time check.
- Estimated rate of movement.
- Need for target adjustment.
- Concept of the operation, to include objective and defensive positions, maneuver control measures, and obstacles.

(2) **Assets.** Find out what assets are available for the operation. Concurrently, send a WARNO to all attack agencies. These include the FA battalion S3, mortar platoon leader, ALO, and brigade aviation LNO (if any are applicable). Obtain the following information:

- *From the FA DS battalion:* the firing units that will be designated to fire in the quick fire plan schedule.
- *From the maneuver commander:* the availability of the mortar platoon (company team FSO to TF FSO for the mortars if a company team operation) for inclusion as a firing unit into the schedule of fires.
- *From the FSE:* CAS mission information. Coordinate CAS requirements with the ALO (for example, aircraft type, ordnance, time on station, laser codes, and control procedures).

(3) **Targets.** Plan targets IAW the scheme of maneuver, commander's guidance, and allocated assets. Include--

- Asset to be used.
- Munitions mix.
- Shell-fuze combinations.

- Duration of fire for each target.
- Time to fire.

(4) **Dissemination.** After receiving the commander's approval, disseminate the fire plan to attack systems, higher headquarters FSEs, and those who will implement the plan (FOs, company team commanders, FIST, scouts, and so on). Whenever possible, send the quick fire plan digitally or use DA Form 5368-R (Quick Fire Plan), to the FA battalion CP and the mortar platoon leader.

(5) **Subordinates.** Ensure that the subordinate FSOs and FISTs understand the fire plan. As a minimum, cover--

- Positions or locations of FSOs and observers during the conduct of the operation.
- Who is to initiate the fire plan or initiate the fire request on specific on-call targets within the fire plan. Include the agency to be contacted, when the target is to be initiated, and the communications net to be used.
- Which unit has priority of fires or priority targets, if applicable.
- The use of methods of control in modifying the plan should it become necessary during execution.
- The agencies available when additional targets of opportunity arise during the execution of the plan.

If time allows, conduct a rehearsal to ensure comprehension of the plan. Inform the commander when the FS plan is ready. Review the FS plan and modify it as necessary.

(6) **Triggers.** Triggers are a physical point on the ground or an action or event. During offensive operations, a trigger is often a maneuver action or event. In the defense, a trigger is more often a physical spot on the ground. The following is the sequence for trigger development.

(a) Determine the position on the ground where you want fires to impact on the enemy or to silhouette the enemy.

(b) Determine the enemy rate of movement. This may be done by estimation, on the basis of past experience, from doctrinal literature, or from scout reports of enemy speed.

(c) Determine the time of flight of the rounds from the weapon system firing the mission.

(d) Determine the processing time. Processing time is the time required from the call for fire to rounds being fired from the weapon system.

(e) Determine the total mission time. The total mission time is time of flight plus processing time.

(f) Place the trigger point the required distance from a planned target location based on the following: total mission time x speed of enemy = distance.

## 9-7. OBSERVATION PLANNING

The observation plan, as an integral portion of the FS plan, should provide the task and purpose for each phase of the operation. The observation plan should be synchronized with the scheme of maneuver during the MDMP. The observation plan is developed in concert with the S2 and S3, using TerraBase computer programs to assist with position selection. The FSO should plan to have observers in position to support the maneuver commander's intent and each EFST. The observation plan should address where the

observer needs to be, security, communications, how the observer gets into position, what the observer is to accomplish, and disengagement criteria if necessary.

a. The following steps are followed in observation planning.

(1) **Identify the Requirements for an OP.** The requirement for an OP is identified during the war game. The OP may be required to execute the R&S plan, trigger artillery, or call for CAS.

(2) **Conduct Terrain Analysis.** Run the TerraBase shot from where the observer needs to see (NAI, TAI, or artillery target) to determine the possible OP locations that have line of sight to the area that needs to be observed.

(3) **Allocate the Asset.** The asset should be chosen based on the mission of the OP. If laser designation is required, then the following are required: an observer equipped with ground/vehicle laser locator designator (G/VLLD), a FIST for execution of artillery targets, an enlisted tactical air controller (ETAC) for CAS, and a scout for observation.

(4) **Select the OP.** The OP should be selected from the possible OPs developed during terrain analysis. The mission and capabilities of the asset on the OP should be considered (for example, angle-T, limited visibility, range of thermals, communications requirements). The enemy situation is also considered.

(5) **Plan for Insertion and Occupation of the OP.** First, determine the method of insertion (for example, air, mounted, or dismounted). Next, plan routes, check points, PZs, LZs, and so on.

(6) **Make Necessary Coordination.** If required, coordinate the passage of the OP through friendly forces. Deconflict the terrain for the OP.

(7) **Support the Insertion and Occupation Plan.** Plan indirect fires, electronic warfare support, medical support, extraction, security, and resupply. Supervise and execute the plan.

b. An observation planning issue that must be addressed at task force level is who owns and positions the FISTs: the task force commander or company team commander. The company team commander needs the FISTs to assist in his fire support planning and to trigger targets assigned to the company team for execution in accordance with the task force scheme of fires. The task force commander or FSO may feel the need to dictate FIST positioning to ensure they are in the proper position at the right time to execute TF--directed targets.

(1) In most cases, how the FISTs are employed and who they work for depends on the amount of certainty of the task force mission.

(a) In a movement to contact, the task force should leave control of the FIST with the company team because the situation is unclear.

(b) In the defense, where targets are fully synchronized with the task force scheme of maneuver, the best course of action may be to put all of the FISTs under centralized control with the task force dictating where they will be positioned.

(c) In a deliberate attack, the task force should consider task-organizing the FISTs to meet specific mission requirements. This may mean either FIST teams working in pairs and moving by bounding overwatch to maintain constant observation or providing the support by fire (SBF) or breach force with a second FIST team to provide redundancy at the point of penetration.

(d) Given the expanded battlespace that the task force will be operating over, it may also be impractical to separate the FIST from its company teams to execute task force missions.

(2) Regardless of how the task force commander chooses to employ his FIST, the task force staff must, at a minimum, provide the FIST with a tentative OP and movement plan. The task force staff, using its TerraBase products, should provide the company team FIST with proposed OP locations (with routes to and from these locations) from which the FIST can best execute its assigned task force mission or support its company team's scheme of maneuver.

### **9-8. TOP-DOWN FIRE PLANNING**

To enhance the focus of fires, formal fire planning is conducted through a deliberate top-down process with bottom-up refinement. This process occurs primarily during the "decide" phase of the "decide, detect, deliver, assess" (D3A) methodology. The primary advantage of top-down fire planning is that the commander develops the fire support plan early, allowing the artillery staff to plan concurrently. This process also allows for quick development of a workable plan that focuses the fires effort exactly where the commander wants it on the battlefield (essential fire support tasks). The dissemination of the plan down and the refinement of that plan up does not stop until the established cutoff time.

a. Digitized systems facilitate the dissemination of plans, provide the commander with near-real-time information on the status of fire support, and allow him to modify and shift the focus of fires as the situation develops. The TF commander can quickly assess where the focus of fires needs to be.

b. Top-down fire planning is based on the concept that the plan originates at higher levels and is refined at lower levels. At the TF level, the commander receives the top-down fire plan from brigade. This plan focuses the fire support effort exactly where the brigade commander wants it on the battlefield (essential fire support tasks). It provides detailed execution guidance, develops essential fire support tasks, allocates resources, assigns target execution responsibility, and fully supports the combined-arms commander's scheme of maneuver. The TF FSO, after receiving this plan, can begin working early to refine targeting information based on how the TF commander intends to integrate his plan into the brigade plan.

c. Top-down fire planning is a continuous process of analyzing, allocating, and scheduling fire support. It determines--

- How fire support will be used and what the essential fire support tasks are.
- What types of targets will be attacked--resulting in the high-payoff target list (decide).
- What type of targets will not be attacked.
- What collection assets are available to acquire and track the targets (detect/track).
- What assets will be used to attack different targets; what munitions, what effects, and when they will be engaged (deliver).
- System preferences for various targets.
- What assets are available to verify (assess) effects on the target.

**NOTE:** When planning fires, it is essential to address the following aspects of each essential fire support task and target: purpose, location, trigger, shooter and backup shooter, communications structure, rehearsal, and delivery assets. If each of these is not identified, planned, resourced, and rehearsed, the successful accomplishment of that essential fire support task is at risk.

d. Planning must be flexible to accommodate unexpected and rapid changes. The brigade plan contains only those essential fire support tasks necessary to support the commander's guidance for fire support. Remaining assets are allocated to the subordinate TF commanders according to the priorities for fire support. In turn, each TF commander develops a fire support plan to support the assigned essential fire support tasks and his scheme of maneuver. He may allocate any assets not planned for down to the company teams for their planning and execution.

e. The allocation of resources in top-down fire planning should be more than the mere "blind" allocation of a number of targets for planning without regard for the purpose and achievable effects during that part of the operation. Allocations at each level should emphasize the purpose, planning, and execution of fire tasks. For example, allocating three targets to a company team commander for planning does not give him the possible purposes of those targets. However, allocating a subordinate a fire task in the form of a TAI for the destruction of a platoon during a certain portion of the operation better accounts for the relationship of fires in time and space. The brigade assigns execution responsibility down to the TF. The TF commander must then assign responsibility within his command. Primary and backup observers must be established.

f. Bottom-up refinement is a key element of top-down fire planning. During the decision-making process, targets and any decentralized digital links are planned on the basis of map reconnaissance and situational templates. Targets must be refined on the basis of the reconnaissance effort, actual occupation of the terrain, and updated intelligence. Digital systems and focusing fires through essential fire support tasks enhance the refinement effort. With the establishment of essential fire support tasks early in the planning process, company team FISTs can be proactive in their refinement and planning. Targets that facilitate the accomplishment of essential fire support tasks can be nominated during the bottom-up refinement early in the planning process.

g. In most cases, if fire support targets need refinement, it is better to delete the obsolete target and plan a new target with a new target number. This prevents confusion by observers and firing units who may receive two grid locations for the same target number. A technique used by many units is to use every fifth target number initially in planning. For example, the initial targets for a plan may be AB 5000 and AB 5005. Then, as those targets are refined, the next higher target number is available for use. For example, if the targets above were refined once they would be changed to AB 5001 and AB 5006. This allows for the tracking of a target as it is refined to help eliminate any confusion as to the original purpose of that target.

## **9-9. BATTLE DAMAGE ASSESSMENT**

Battle damage assessment (called target damage assessment [TDA] in AFATDS) is the timely and accurate estimate of damage resulting from the application of military force, either lethal or nonlethal, against a target. BDA is primarily an intelligence responsibility

but requires coordination with operational elements to be effective. Commanders use BDA to get a series of timely and accurate snapshots of their effects on the enemy. This helps determine when or if the targeting objectives are being met. BDA also helps determine if restrike is necessary. The targeting team must keep the following BDA principles in mind:

- BDA must measure things that are important to the commander, not make things important that are easily measurable.
- BDA must be objective.
- The degree of reliability and credibility of the assessment relies largely upon collection resources and their quality as well as quantity.

### **9-10. FIRE SUPPORT COORDINATION**

FS coordination is the continuous process of implementing FS plans and managing all available FS assets. Coordination involves operational, tactical, and technical considerations and the exercise of FS C3. It provides a way to deconflict attacks, reduce duplication of effort, facilitate shaping of the battlefield, and avoid fratricide. Coordination procedures must be flexible and responsive to change, with simplified arrangements for approval or concurrence. FS personnel must clearly understand the commander's intent. The task force commander, through his staff, liaison, and coordination elements, ensures synchronization of available FS assets to place the right attack means on the correct target at the precise time. To achieve synchronization and effects coordination, particularly in joint operations, the task force commander and the staff must have a thorough knowledge of all components' basic doctrine, major systems, capabilities and limitations, and often the component's tactics, techniques, and procedures. The following are some general guidelines for FS coordination during offensive or defensive operations.

- a. Position fire delivery units effectively.
- b. Coordinate use of CAS to support commander's intent.
- c. Ensure FSOs and observers know the exact locations of maneuver boundaries and other FSCMs.
- d. Position observers in redundancy where they can see their assigned targets and trigger points, communicate with FS assets, and respond to the maneuver commander.
- e. Establish FA final protective fires or priority targets.
- f. Plan FA illumination to facilitate direct fire during limited visibility.
- g. Provide common survey data to mortars.
- h. Provide meteorological (MET) data to mortars.
- i. Use a fire support execution matrix (FSEM) to execute FS. Remain flexible to branches or sequels to the current plan. Fight the enemy, not the plan.
- j. Develop and disseminate FA-delivered FASCAM safety boxes in coordination with the engineer and S3.
- k. Coordinate with the FA battalion TOC to develop the attack guidance matrix using munitions effects. Compute ammunition requirements to suppress, neutralize, or destroy expected enemy target categories. Provide these results to the commander so that he can formulate his commander's attack guidance.
- l. Disseminate target priorities to the lowest levels of the maneuver force, FS staff, and mortars.

- m. State the commander's attack guidance by defining how, when, with what restrictions, and in what priority the commander wants to attack different targets.
- n. Limit the number of targets to 10 to 15 per maneuver TF, with no more than 45 to 60 for the entire brigade.
- o. Require subordinates to finish refinement by cutoff time.
- p. Determine the risk the commander is willing to accept concerning indirect fires on close contact.
- q. Verify or correct target locations and trigger points during refinement.
- r. Use FSEM to brief the fires portion of the OPORD during a combined arms rehearsal.
- s. Ensure FSEs and maneuver commanders clearly understand methods to be used for battle tracking and clearance of indirect fires.
- t. Verify range of Q-36, FA, and mortar coverage based on shell or fuze and charge.
- u. Explain FS combat power in terms the maneuver commander understands, to include the following:
  - The number and types of missions.
  - Battery, battalion, and mortar volleys by type of ammunition and effects expected.
  - Minutes of smoke and allocation.
  - Minutes of illumination and allocation.
  - Number of available FASCAM minefields by size, type, density, and safety zone.

### 9-11. REHEARSALS

Rehearsals are an integral part of the planning process. The FSO should participate in the maneuver commander's rehearsal. Rehearsals improve total comprehension of the plan. Participants who are unclear on specific portions of the plan find answers through the repetitiveness afforded by rehearsing the operation. Combat rehearsals are conducted to help a unit gain agility, to ensure synchronization, to increase initiative, and to improve depth of knowledge through practice. Both FS and maneuver actions should be rehearsed to reinforce the scheme of maneuver and fire plan. Rehearsals should both practice and test the plan. Rehearsal procedures should be established as part of unit SOPs. As a minimum, SOPs should identify--

- Who will participate in the rehearsal?
  - What should be rehearsed?
  - What is the sequence of the rehearsal?
  - What is the priority of methods for rehearsals (suitable or actual terrain; model, map, sand table, wire, or radio)?
- a. **Combined-Arms Rehearsals.** Key players include all fire support personnel, the maneuver staff, mortar platoon leader, chemical officer, signal officer, ALO, aviation LNO, MI platoon leader, scout platoon leader, and engineer officer.
- (1) Normally, the unit S3 drives the rehearsal using a synchronization matrix, execution checklist, or both; the FSO uses his FSEM. Thus, the rehearsal normally includes recitation or performance of the following:
- Actions to occur.
  - Possible friendly initiatives.



- Possible reactions to enemy initiatives.
- Control measures.
- Significant events that are to occur in relation to time or phases of the operation.

(2) For each phase or time period of the operation the FSO should, as a minimum--

- Verify grid locations for all critical targets.
- Verify trigger points for each target.
- Verify engagement criteria.
- Confirm primary and backup observers for each target.
- Verify primary and backup communications links for each observer.
- Verify that each target has a task and purpose (what effects are to be achieved).
- Verify the method of engagement (at my command, time on target, or when ready).
- Verify that attack guidance, such as shell-fuze combination, number of volleys, and units(s) to fire, is specified for each target.
- Verify the movement plan, specifying when and where units and observers will move.

b. **FSO Fire Support Rehearsals.** Even when units conduct combined maneuver and FS rehearsals, all members involved in providing FS cannot be present, and units do not rehearse refinements or changes made to the plan. Therefore, combined rehearsals are normally followed by fire-support-only rehearsals that include all FS executers from the observer to the delivery asset, when possible. These serve to refine the FS plan, ensure understanding by all FS personnel, and prove the feasibility of executing the current plan. The brigade FSO or FSCoord normally runs these FS rehearsals if they include the DS artillery firing batteries. The TF FSO and FIST should, if at all possible, participate in the brigade fire support rehearsal. However, it may be necessary for the TF FSO to conduct his own internal TF FS rehearsal either before or after the brigade FS rehearsal.

(1) FS rehearsals are executed using the FSEM as a script for executing fires to support the scheme of maneuver. The FA battalion uses and verifies the FA support plan.

(2) The FSO establishes the time for all key participants to conduct the rehearsal. The FSO begins the rehearsal by announcing key times or phases of the operation. Each participant then executes the actions he will take, normally just short of actually delivering fires on the appropriate target.

(a) *Fire Support Officers.* FSOs (to include the FSO conducting the rehearsal) verify they can observe their assigned targets and trigger points, fire their assigned targets, place FSCM into effect, and make reports on which the system depends for its combat information.

(b) *Forward Observers.* FOs do the same as FSOs, while ensuring high priority missions (such as PPFs or priority targets) are loaded in the buffers of their digital message devices and ensuring that signals for lifting and shifting fires are understood.

(c) *Air Liaison Officer.* The ALO monitors airspace coordination, clears aircraft to depart the initial point, calls for target marking and marking of friendly locations, and requests initiation of SEAD.

(d) *Direct Support Task Force or Mortar Platoon/Section Leader.* Firing unit leaders monitor and ensure that--

- Units are displaced to support the plan.
- The FDC issues fire orders and passes messages to observers.
- Radars are cued on assigned azimuths.
- Firing unit FDCs compute firing data and issue fire commands, acknowledge FSCM changes, and ensure they can fire their assigned targets.
- Howitzer and mortar section leaders determine whether ammunition is on-hand and whether missions are within traverse and transfer limits.

(3) If a combined maneuver and fire support rehearsal has not been conducted, the FSO should also cover the information listed in paragraph 9-11a. FS personnel may also rehearse alternative friendly courses of action (branches and sequels to the plan) if time permits.

(4) Rehearsals can conclude with a summary of each unit's status (to include firing unit ammunition status) and location. This facilitates planning for future operations.

## 9-12. CLEARANCE OF FIRES

The execution of the scheme of fires must provide for the clearance of fires. Clearance of fires ensures that fires attack enemy capabilities at the time and place and with the effects the commander desires, without resulting in casualties to friendly forces or noncombatants. Clearance of fires may be accomplished through a staff process, through control measures, embedded in automated battle command systems, or through active or passive recognition systems. During planning and execution, the commander can use all of these means in various combinations to set the conditions for clearance of fires. Even with automated systems, clearance of fires remains a command responsibility at every level, and each commander must assess the risk and decide to what extent he will rely on automated systems to assist in the clearance of fires. The task force commander is responsible for the clearance of fires within the task force area of operations. He normally delegates coordination responsibility to the task force FSO, who establishes the mechanism the task force will use to clear fires.

a. **Maneuver Control Measures.** The first step in clearance of fires is the use of maneuver control measures. Boundaries serve as both permissive and restrictive measures. If no boundaries are established, then the next higher headquarters must clear all fires short of the FS coordination line (FSCL) or coordinated fire line (CFL). Thus, boundaries should be used whenever possible because they allow the unit that "owns the ground" to engage targets quickly, requiring coordination and clearance only within that organization. Boundaries divide up battlespace and define responsibility for clearance of fires.

b. **Fire Support Coordinating Measures.** The next step in effective clearance of fires is the proper use of FSCMs. Permissive FSCMs (FSCLs and CFLs) should be established far enough out to protect ground forces. Forces beyond either of those FSCMs should be protected with a restrictive measure, such as a no-fire area.

**NOTE:** A CFL only applies to surface-to-surface fires; therefore, all CAS missions must be cleared.

c. **Preclearance.** The third step is to make a determination as to which fires can be precleared. In the following very specific instances, fires can be cleared during the planning phase:

- Fires into a planned call for fire zone (CFFZ) resulting from a radar acquisition from that planned CFFZ.
- Fires on a preplanned target, with a definable trigger, against a specific enemy, and according to the concept of fires.

d. **Clearance of Fires Drill.** Clearance of fires should be a drill in all command posts and operation centers. The best method is a redundant drill where a call for clearance is transmitted over two nets: the FS net and a maneuver net.

e. **Targets of Opportunity.** Positive clearance of fires is normally facilitated through prior planning, rehearsals, and careful placement of FSCMs. However, the clearance of targets of opportunity often presents challenges. Fires on targets of opportunity must be delivered on short notice without undue delay and without jeopardizing friendly force security. For positive clearance of fires, the following should be obtained:

- The best available method of target location.
- Positive identification of targets as enemy.
- Eyes on target, if at all possible.
- Clearances from appropriate external elements if target is outside unit boundaries.

### 9-13. AFATDS AND CLEARANCE OF FIRES

All fires need to be cleared. Units can use a combination of digital and analog methods to clear fires. Even with the enhanced information offered by digital systems, there will be instances where fires require voice coordination before clearance.

a. **Coordination.** Coordination is required when the effects area around the target violates one or more FSCMs or zones of responsibility (ZORs). When coordination is required before firing a mission, the unit establishing the FSCM or the unit responsible for the ZOR must approve a coordination request.

b. **Target Processing Guidance Effecting Coordination.** The minimum safe distance is used to determine which targets require coordination due to their proximity to friendly units. The system looks at FSCMs in the database and adds the buffer distance to the aim point of a mission to determine if a violation has occurred. This guidance should be a matter of SOP.

c. **Preclearance.** During the planning process, commanders should consider the FS tasks that can be precleared. Precleared fires are specified FS tasks. During the planning process, the commander can leverage the capabilities of digital systems to set the conditions required for the execution of that task without clearance confirmation at the time of execution. Examples of conditions that a commander can set include the following:

- The fires do not violate any established maneuver control measure or FSCM.
- The observer executing the fires has positive identification of the target and it meets the established engagement criteria.

- The observer executing the target meets established position location parameters that ensure accurate target location.
- The execution of and the digital links established for the mission have been planned and rehearsed prior to the operation.

#### **9-14. FBCB2 AND CLEARANCE OF FIRES**

FBCB2 in and of itself does not prevent fratricide. It does, however, provide a powerful tool to reduce the risk of fratricide. Being able to see where other friendly vehicles are positioned on the battlefield facilitates recognition of friend from foe. However, every friendly vehicle on the battlefield may not appear on FBCB2 screens. There will be friendly vehicles that are not equipped with FBCB2, dismounted troops, and vehicles whose systems are down or, based on the network, do not appear on other units' FBCB2s. Although FBCB2 can help with reducing incidents of fratricide, it does not replace the need to train crews to recognize enemy vehicles and use common sense before engaging.

a. FBCB2 can be used to facilitate the clearance of indirect fires, but it should not be used as the sole means for clearing fires. Every friendly vehicle operating within the area of operations will not appear on FBCB2 screens. This is especially true of dismounted scouts, brigade reconnaissance troop sections, and dismounted infantry. Once separated from their vehicles, these elements no longer generate an icon on FBCB2 unless they are equipped with a dismounted FBCB2 (which will probably not be fielded until 2005 or later).

b. Friendly filter settings also affect the accuracy of the FBCB2 picture of where friendly units and vehicles are located. For example, a vehicle that has its update filter setting set to one hour or 1,000 meters can move up to 1,000 meters from its last updated position without FBCB2 reporting that it has moved. This could easily place the vehicle within the impact area of an indirect fire mission. The echelon and unit type filter settings on FBCB2 can also cause a friendly unit icon not to appear on an FBCB2 screen.

c. All of these limitations of FBCB2 must be considered in establishing the unit SOP on how to use the system to facilitate the clearance of indirect fires. Fire support coordination measures and positive control of fires are still necessary. Plan no-fire areas over dismounted positions, especially those forward of the line of departure or battle positions. If the fire mission plots on top of a friendly icon, then it should not be shot without coordination. If there is no icon on or near the target grid and the unit calling for fires has eyes on the enemy, then it is probably safe to shoot unless there are friendly dismounted soldiers operating in the area. If the unit calling for fires does not have eyes on the target, then use FBCB2 to locate the closest friendly unit to the target grid to see if they can get eyes on the target or if the fire mission will affect any of their elements.

d. FBCB2 cannot be used as the sole means for clearing fires, but it can be used to deny fires. It does not replace the need for positive clearance of fires, use of fire support coordinating measures (CFZs and censor zones [CZs]), or eyes on the target.

#### **9-15. RADAR ZONES**

At the task force level, two types of zones are most important: critical friendly zones and censor zones. It is the TF FSO's and or the FS NCO's responsibility to ensure CFZs are planned at places critical to the maneuver commander's force protection plan, refined during the rehearsal process, and adjusted during the fight to ensure they're emplaced

where the critical friendly elements are located. If no radar zones are established, firefinder radars will still acquire targets (if they are cueing) and will pass the intelligence to the artillery TOC (they can be converted to a call for fire and fired at that time). All the establishment of CFZs and call for fire zones (CFFZs) does is change the format of the firefinder report to a call for fire and place a higher priority on it. This method allows the initial fire support automation system (IFSAS) and AFATDS to handle the CFF as soon as it is received. Still, the proper establishment of radar zones can expedite the reactive counterfire process.

a. **Critical Friendly Zone.** The CFZ designates the highest priority friendly locations of the maneuver commander and provides the most responsive priority of fires from the counterfire radars (Q-37/Q-36). Cued radars detecting incoming rounds into the zones immediately generate a priority request for fire. The TF FSO should recommend to the task force commander positioning of allocated CFZs and their size for best responsiveness. The task force should plan and request CFZs to protect assembly areas, TOCs, SBF positions, breach sites, passages through choke points, refuel and rearm sites, and other troop concentrations.

(1) During offensive operations, the TF should consider breach sites and attack by fire/support by fire locations

(2) During defensive operations, the TF should consider battle positions and key observer positions.

b. **Censor Zone (CZ).** A CZ is used to designate an area from which the commander does not want to attack targets. At task force level, this zone is used to help protect the task force mortar section. On a fluid and nonlinear battlefield, the task force mortars can occupy positions or execute fire missions that a friendly firefinder radar could misidentify as hostile. In these situations, a CZ covering the mortars coupled with the establishment of a no-fire area around the mortar position dramatically reduces the risk of fratricide.

c. **Radar Zones.** Radar zones should meet the following guidelines:

(1) Does it meet the commander's guidance for force protection?

(2) Do I have a good trigger to turn it on?

(3) Does it fit the scheme of maneuver?

(4) Is there a firing unit in range with the correct ammunition?

(5) Does it meet the following guidelines:

- Zones cannot intersect or touch another zone.
- Must have minimum of three points and a maximum of six points.
- Grid coordinates must be listed in sequence (clockwise or counterclockwise).
- Grid coordinates cannot be outside the search sector (except CFZs).

d. **Management.** The task force FSO and FSE are responsible for managing radar zones allocated to the task force and requesting zones if the task force commander does not feel he has been allocated sufficient coverage to protect his force. During the planning process, the commander should provide guidance on the use of radar zones, and the FSO and staff should plan the location of the zones and when they need to be active. During execution, the FSO and FSE must track the battle to activate and deactivate zones and adjust zone location as necessary to meet the commander's intent. For example, the task force is allocated two CFZs to protect its support by fire position and breaching forces during a deliberate attack. These CFZs should not be activated until the forces they

are designed to protect actually occupy the SBF position and establish the breach site. The task force FSE then must confirm the planned zones cover where the friendly forces actually are on the battlefield. This can be done either by the COP provided by FBCB2 or through voice reports. If the planned zones do not protect the designated force, the FSE must contact the DS battalion S2 or supporting radar to move the zones. The FSE is also responsible for deactivating the zones when the unit moves and they are no longer required or they have accomplished their task and purpose.

**9-16. FIRE SUPPORT ASSETS**

Field artillery is the maneuver commander’s principal means for providing indirect fire support to his maneuver forces. Field artillery can neutralize, suppress, or destroy enemy direct fire forces; attack enemy artillery and mortars; and deliver scatterable mines to isolate and interdict enemy forces or protect friendly operations. Field artillery elements within maneuver organizations serve as the integrating center for all elements of fire support. Field artillery delivery systems include cannons, rockets, and missiles. These systems can provide fires under all conditions of weather and in all types of terrain. They can shift and mass fires rapidly without having to displace. Field artillery units are usually as mobile as the units they support. They are organized for combat to provide responsive and effective FA fires and to coordinate all fire support. The four tactical missions and seven inherent responsibilities of the field artillery are shown in Table 9-4.

<b>An FA Unit with the Mission of:</b>	<b>Direct Support</b>	<b>Reinforcing</b>	<b>General Support Reinforcing</b>	<b>General Support</b>
<b>Answers calls for fire in priority from:</b>	1. Supported unit 2. Own observers <sup>1</sup> 3. Force FA HQ.	1. Reinforced FA 2. Own observers <sup>1</sup> 3. Force FA HQ.	1. Force FA HQ. 2. Reinforced unit <sup>1</sup> 3. Own observers <sup>1</sup>	1. Force FA HQ 2. Own observers <sup>1</sup>
<b>Has as its zone of fire:</b>	Zone of action of supported unit	Zone of fire of reinforced unit	Zone of action of supported unit to include zone of fire of reinforced unit	Zone of action of supported unit
<b>Furnishes Fire Support Personnel to<sup>2</sup>:</b>	Provides temporary replacements for casualty losses as required	No requirement	No requirement	No requirement
<b>Furnishes Liaison to:</b>	No requirement	Reinforced FA unit HQ	Reinforced FA unit HQ	No requirement
<b>Establishes Communications with:</b>	Company team FSOs and supported maneuver unit HQ	Reinforced FA unit HQ	Reinforced FA unit HQ	No requirement
<b>Is positioned by:</b>	DS FA unit commander or as ordered by force FA HQ	Reinforced FA unit or as ordered by force FA HQ	Force FA HQ or reinforced FA unit if approved by force FA HQ	Force FA HQ
<b>Has its fires planned by:</b>	Develops own fire plan	Reinforced FA unit HQ	Force FA HQ	Force FA HQ
1. Includes all target acquisition means not deployed with supported unit (radar, aerial observers, survey parties, and so on).				
2. The FA unit trains and deploys one FSE for each TF and one FIST for each company team. After deployment, FISTs and FSEs remain with the supported maneuver unit throughout the conflict.				

**Table 9-4. Seven inherent responsibilities of field artillery.**

a. **Cannon.** FA has various cannon systems designed for supporting specific types of maneuver operations. These systems are complemented by a wide variety of munitions to attack the multitude of target types.

(1) **Paladin, M109A6.** The M109A6 Paladin howitzer is an armored, full tracked howitzer carrying 37 complete conventional rounds and two copperhead projectiles. The Paladin uses an automatic fire control system (AFCS) that provides position location and directional reference, a ballistic computer for onboard technical fire control, and gun-drive servos, which automatically lay the gun for deflection and elevation. A remotely operated travel lock allows the crew to emplace and displace without dismounting from the vehicle. The Paladin has a maximum rate of fire of three rounds per minute for the first three minutes followed by a one-round-per-minute sustained rate of fire. The M109A6 fires the full complement of 155-mm ammunition with a maximum range of 22 kilometers for unassisted projectiles, 30 kilometers for the rocket-assisted projectile (RAP) and 27 kilometers for the base-burn dual purpose improved conventional munitions (BBDPICM).

(2) **Cannon Munitions.** These include the XM982 extended range dual purpose improved munition (ER-DPICM) and sense and destroy armor (SADARM).

(a) **XM982 Extended Range Dual Purpose Improved Munition.** The XM982 projectile carries DPICM, sense and destroy armor (SADARM), or a unitary warhead (Penetrator) payload. The warhead is composed of 65 XM85 DPICM bomblets with self-destruct mechanisms, two product improvement (PI) SADARM submunitions, or one unitary projectile bunker-penetrating HE warhead. The maximum associated ranges are 37 to 40 kilometers with the M109A6 and M198.

(b) **Sense and Destroy Armor.** The sense and destroy armor projectile is a 155-mm, fire-and-forget, top attack, counterfire munition. The system utilizes millimeter wave radar and infrared sensors to locate targets and provide countermeasure resistance. The warhead is an explosively formed penetrator designed for top attack penetration of self-propelled howitzers and lightly armored combat vehicles. The maximum associated range is 22.5 kilometers with the M109A6 and M198.

b. **Multiple-Launched Rocket System (MLRS).** The following types of MLRSs are available for FS:

(1) **M270/M270A1 MLRS Self-Propelled Loader-Launcher (SPLL).** The M270 MLRS is a mobile, self-propelled, self-loading, multiple launch rocket system. It provides mobile long-range artillery rocket and missile support for ground forces. The M270A1 is capable of firing the entire MLRS family of munitions to include all Army tactical missiles. The M270A1 is capable of holding either two launch pod containers of six rockets per container or two guided missile launch assemblies containing one missile each. With the M26A1 extended range rocket, the MLRS SPLL can fire 12 rockets in 60 seconds at multiple aimpoints out to a range of 50 kilometers. It also has the capability of firing two missiles aimed at one or two separate aimpoints in 20 seconds.

(2) **High-Mobility Artillery Rocket System (HIMARS).** HIMARS is a highly mobile, quickly deployed, rapid-fire, surface-to-surface rocket and guided missile system. It complements cannon artillery and MLRS fires to attack the enemy deep and to strike at counterfire, air defense, and HPTs. The HIMARS battalion can be attached to an FA brigade or to division(s) within the corps. HIMARS batteries and platoons may be attached to other artillery units (such as cannon battalions) to form a fire support task

force. The HIMARS is a wheeled version (5-ton family of medicum tactical vehicles [FMTV]) of the MLRS designed to meet the increased mobility and transportability requirements for global contingencies. The HIMARS also provides inter- and intra-theater deployability by C-130 or larger aircraft. The C-130 has a short takeoff and landing capability on airfields unsuited for other airlift resources and permits rapid insertion of HIMARS into a contingency area and redeployability of HIMARS to critical areas within the theater of operations. The HIMARS can fire all the current and near-term MLRS family of munitions. The HIMARS launcher uses onboard tactical fire control and position-locating systems that are comparable to the M270 improved position determining system launcher. Unlike the M270, however, the HIMARS launcher loader module holds only one rocket or missile pod.

(3) **M26 Tactical Rocket.** The MLRS M26 is a free flight unguided tactical rocket that provides an all-weather, indirect fire capability designed to complement cannon fires. The M26's range is approximately 32 kilometers.

(4) **Extended-Range Rocket (ER-MLRS).** The ER-MLRS rocket consists of a materiel change to the M26 rocket. The extended range is 45 km, and the dud rate is less than one percent. The warhead is composed of 518 XM85 submunitions.

(5) **Guided MLRS Rocket (GMLRS).** The GMLRS represents an improvement in accuracy to reduce rocket expenditure to one sixth the current quantity at maximum ranges. With the addition of low-cost jam-proof guidance and control, a two to three mil delivery accuracy is achieved. The maximum range is 60 km. The improved accuracy of the rocket reduces a unit's logistics burden, increases crew survivability, and reduces collateral damage by increasing the capability to engage point targets.

(6) **MLRS Smart Tactical Rocket (MSTAR).** The MSTAR is a guided MLRS rocket carrying smart submunitions out to a range of approximately 60 kilometers. These submunitions use onboard sensors to detect, classify, and engage stationary or moving targets.

c. **Army Tactical Missile Systems (ATACMSs).** The following types of ATACMSs are available for FS:

(1) **ATACMS Block I.** ATACMS Block I is designed to engage "soft" stationary targets to a range of 165 km. The target set includes air defense units, C3, surface-to-surface missile units, logistical sites, and helicopter forward operating bases. ATACMS Block I is a highly responsive, semi-ballistic, all-weather missile. The missile carries approximately 950 antipersonnel, antimateriel M74 bomblets. It has three programmable dispense patterns and has off-axis launch capability. One M270 launcher load is equal to two missiles. The missiles can be shot within 20 seconds of one another and at different targets.

(2) **ATACMS Block IA.** ATACMS Block IA complements Block I and is designed to engage "soft" targets to a 300-kilometer range. The target set includes air defense units, C3, surface-to-surface missile units, logistical sites, and helicopter forward operating bases. ATACMS Block IA is a highly responsive, semi-ballistic, all-weather missile. The missile carries approximately 310 antipersonnel, antimateriel M74 bomblets. The missile maintains its effectiveness over the greater range due to its embedded global positioning system (GPS) for guidance. The ATACMS Block IA is fired from M270 launchers that are modified with the improved position determining system, a GPS antenna, various interface cables, and new armored doors at the back of the launcher-loader module. It has



three programmable dispense patterns and has off-axis launch capability. One M270A1 launcher load is equal to two missiles. The missiles can be shot within 20 seconds of one another and at different targets.

(3) **ATACMS Block II.** ATACMS Block II is a semi-ballistic, surface-to-surface guided missile that carries 13 brilliant antitank technology (BAT) submunitions or BAT P3I submunitions to ranges of 140 km. The ATACMS Block II missile is an adaptation of the ATACMS Block I missile fielded with modifications to accommodate the BAT submunition. The primary target set for the missile is large battalion-size concentrations of moving armor. Once dispensed, the BAT submunition is capable of autonomously seeking and destroying moving armored targets through use of acoustic and infrared sensors. The BAT preplanned product improvement (P3I) submunitions expand the target set to include hot or cold, stationary or moving, and hard or soft targets, including surface-to-surface missile transporter-erector launchers.

(4) **ATACMS Block IIA.** ATACMS Block IIA is a semi-ballistic, surface-to-surface guided missile that carries six BAT P3I submunitions to ranges from 100 to 300 kilometers. Once dispensed, the BAT P3I submunition is capable of autonomously seeking and destroying moving or stationary targets through use of acoustic, millimeter wave, and infrared sensors. The BAT P3I submunitions target set includes hot or cold, stationary or moving, and hard or soft targets, including surface-to-surface missile transporter-erector launchers. The submunition has increased performance over the basic BAT submunition in adverse weather and countermeasure environments.

## **9-17. MORTARS**

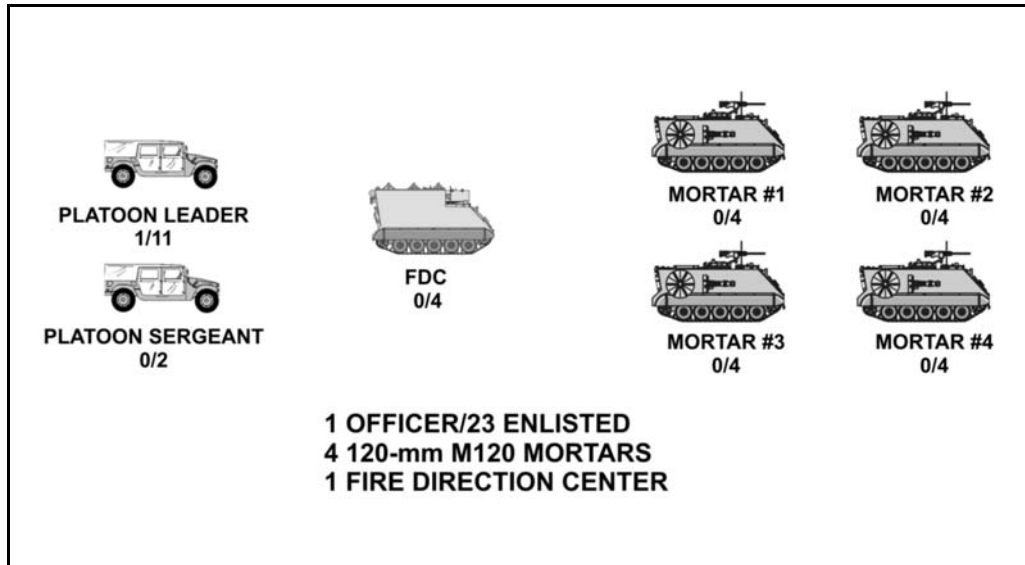
The mission of mortars is to provide immediate and close supporting fires to the maneuver forces in contact. Maneuver unit mortars provide close, immediately responsive fire support for committed TFs, company teams, and troops. These fires harass, suppress, neutralize, and destroy enemy attack formations and defenses; obscure the enemy's vision; and otherwise inhibit his ability to acquire friendly targets. Mortars can also be used for final protective fires, smoke, and illumination.

a. Mortars are organic to all maneuver TFs and to the company teams of light infantry units. The maneuver commander decides how and when mortars, as a key fire support asset, will be integrated into his battle plan. However, since they are fire support assets, the FSO should give advice and make recommendations to the commander. The amount of control the FSO has over the employment of available mortars is a matter for the supported unit commander to decide. The commander may specify mortar support for subordinate units by changing the command relationship, assigning priority of fires, or assigning priority targets.

b. Mortars are high-angle, relatively short-range, high-rate-of-fire, area-fire weapons. Their mobility makes them well-suited for close support of maneuver. They are ideal weapons for attacking targets on reverse slopes, in narrow gullies, in ditches, in UO, and in other areas that are difficult to reach with low-angle fire. However, their ammunition-carrying capacity limits mortar periods of firing (Table 9-5, page 9-26).

c. The TF mortar platoon consists of four mortar squads, each with one 120-mm M120 mortar, a single FDC, and a headquarters consisting of a platoon leader, platoon sergeant, and two enlisted drivers/radiotelephone operators (RATELOs) (Figure 9-1). The M120 mortar is capable of firing fifteen rounds per minute for the first minute with a

sustained rate of fire of four rounds per minute after the first minute. It is capable of firing high explosives, illumination, and white phosphorus rounds to a maximum range of 7,200 meters. The M120 mortar with base plate weighs 320 pounds and is transported in the M1064 mortar carrier. The mortar platoon is organic to the TF headquarters and headquarters company.



**Figure 9-1. Task force mortar platoon.**

(1) This mortar platoon organization is a reduction in size from the Army of Excellence's division organization, which contained six mortar squads and two fire direction centers. This reduction in combat power and command and control structure has a significant impact on the platoon's employment flexibility and the support provided to the task force. The platoon can still be deployed in sections but with significant limitations. Fires from a single section are limited, and without the second FDC, one section has to compute its own technical firing data. The lack of a second FDC affects the section's battle tracking, responsiveness, ability to accept and apply meteorological messages from the direct support artillery battalion, and accuracy. The reduction of the platoon's combat power by one third also reduces its ability to provide fires in support of the scheme of maneuver. The platoon can deliver thirty fewer rounds per minute at its maximum rate of fire and eight fewer rounds per minute at its sustained rate of fire. Mortar FPFs and smoke screens are also one third smaller. A range and lateral spread illumination mission requires all four squads to shoot illumination and could affect the platoon's ability to execute an HE or WP mission in conjunction with the illumination.

(2) These limitations, however, are not insurmountable. They can be overcome with detailed planning and coordination. The mortar platoon must be given specific tasks that are within its capabilities to accomplish. Synchronization of the mortar fire plan and scheme of maneuver with the task force fire plan and scheme of maneuver are critical to realizing the full potential that the mortar platoon brings to the battlefield. The mortar platoon leader must participate in the task force planning process and rehearsals; this is the only way the task force can ensure the mortar platoon can accomplish its essential fire support tasks and provide immediately responsive fires to the task force.

ADVANTAGES	LIMITATIONS
Fast response rate	Short range
High rate of fire	Limited ammo carrying capacity
Fire from deep defilade	Ammo resupply
Fire without FDC	Less accurate in high winds
High-angle fire	Detected by radar
Attack targets on reverse slopes	Ineffective against point targets
Simplicity	Lack of organic survey and MET

**Table 9-5. Advantages and disadvantages of mortars.**

- d. The task force mortar platoon provides the commander with the following:
- An organic indirect fire capability that is always present and always responsive to the maneuver commander regardless of the changing demands placed on any supporting field artillery.
  - Supporting fire that is immediately at hand and close to the company team and TF fight. The mortar section or platoon is aware of the local situation and ready to respond quickly without lengthy coordination.
  - Unique plunging fires that complement, but do not replace, the heavier fires of supporting field artillery, close air support, and naval gunfire.
  - Weapons whose high rate of fire and lethality fill the gap between the field artillery fires' shift to deeper targets and the assault elements' closing onto the objective.
  - A solid base of fire upon which to anchor his maneuver against the critical point of enemy weakness.

e. Mortars allow the maneuver commander to place killing indirect fires on the enemy quickly, independent of whether the commander has been allocated supporting artillery. Heavy forces use carrier-mounted mortars to allow the mortar platoon to move cross-country at speeds compatible with the battalion task force. All mortar sections and platoons exist to provide immediate, organizationally responsive fires that can be used to meet the rapid changes in the tactical situation on the battlefield.

f. There are three primary types of mortar fires.

(1) **High Explosive.** High-explosive rounds are used to suppress or kill enemy dismounted infantry, mortars, and other supporting weapons and to interdict the movement of men, vehicles, and supplies in the enemy's forward area. Bursting WP rounds are often mixed with high-explosive rounds to enhance their suppressive and destructive effects.

(2) **Obscuration.** Obscuration rounds are used to conceal friendly forces as forces maneuver or assault and to blind enemy supporting weapons. Obscuration can be used to isolate a portion of the enemy force while it is destroyed piecemeal. Some mortar rounds use bursting WP to achieve this obscuration; others employ more efficient technology. Bursting WP is also used to mark targets for engagement by other weapons, usually aircraft, and for signaling.

(3) **Illumination.** Illumination rounds are used to reveal the location of enemy forces hidden by darkness. They allow the commander to confirm or deny the presence of the

enemy without revealing the location of friendly direct fire weapons. Illumination fires are often coordinated with HE fires both to expose the enemy and to kill or suppress him.

### **9-18. MORTARS IN THE TASK FORCE CLOSE FIGHT**

Suppressing the enemy inhibits his fire and movement while allowing friendly forces to gain a tactical mobility advantage. In the company- and battalion-level battle, mortar fire acts both as a killer of enemy forces and as an enhancer of friendly mobility.

a. Mortars provide the commander with immediately responsive fires to support the task force scouts' infiltration and exfiltration and the counterreconnaissance force during security operations.

b. Field artillery assets at all levels are limited. For brigade and division commanders to concentrate offensive combat power at the critical point, they must decentralize elsewhere. Some maneuver units will always have less artillery support than others. Mortars compensate for this and reduce the degree of combat risk.

c. TF mortars allow brigade commanders to divert field artillery fire support for limited periods to win the critical fight elsewhere.

d. Mortars contribute to the task force's direct firefight by forcing the enemy to button up, obscuring his ability to employ supporting fires and separating his dismounted infantry from their armored personnel carriers (APCs) and accompanying tanks. The task force's direct fires become more effective when used against buttoned-up enemy armor.

e. Heavy mortars can penetrate buildings and destroy enemy field fortifications, preparing the way for the dismounted assault force.

f. Mortars guarantee the task force and company team commanders the ability to cover friendly obstacles with indirect fire, regardless of the increasing calls for artillery fire against deep targets or elsewhere on the battlefield.

g. Mortar fire combines with the FPF of a company team's machine guns to repulse the enemy's dismounted assault. This frees artillery to attack and destroy follow-on echelons, which are forced to slow down and deploy as the ground assault is committed. Mortars can use the protection of deep defilade to continue indirect fire support even when subjected to intense counterfire.

h. Mortars can provide obscuration and suppression to protect the task force during the attack or to support it when breaking contact with the enemy in the defense or movement to contact.

i. Mortars can fire directly overhead of friendly troops from close behind the forward elements. This allows combat power to be concentrated and synchronized on close terrain.

j. Whenever possible, commanders should use their mortars first because in most situations, the fires can be cleared and fired faster than other fire support assets. When deploying, commanders should consider the following:

- Register as soon as possible and, if possible, in every position.
- Anticipate ammunition requirements. Local unit ammunition caches may have to be established to aid in distribution.
- Echelon mortars with other fire support assets in the attack.

- Make sure the mortar platoon understands the scheme of fires. Include the mortar platoon in the planning process, backbriefs, rehearsals, and communication exercises. Put them into and provide them with a fire support execution matrix.
- Coordinate for survey and MET support from the direct support field artillery battalion (at a minimum, plan for a declination station).

### **9-19. CLOSE AIR SUPPORT**

Air Force, Navy, Marine, or allied aircraft may provide close air support missions. Most modern aircraft have an inherent flexibility that allows them to be used in different roles as the situation dictates. This means that an aircraft can perform missions other than the mission for which it was specifically designed. To obtain the most use from the air assets available, the JFC apportions air assets against various missions. The types of aircraft used for combat air operations vary widely; however, they can be categorized in broad terms as fighter, bomber, attack, or reconnaissance. See Section II for a discussion of close air support.

### **9-20. ARMY AVIATION**

Army aviation (rotary-wing) units perform the full spectrum of combat, CS, and CSS missions. Aviation units destroy enemy forces by fire and maneuver, perform target acquisition and reconnaissance, enhance C2, and move personnel, supplies, and equipment in compliance with the overall scheme of maneuver. In support of the fire support mission, aviation functions in the following roles:

- Aerial observation and calls for fire.
- Insertion of combat observation lazing teams (COLTs) and Strikers.
- Air movement of weapons systems and ammunition.
- Air reconnaissance.
- Intelligence EW.
- Attack helicopter operations.
- Aerial mine delivery.
- Medical evacuation.
- Search and rescue.
- C2 for joint air attack team (JAAT) operations.

Aviation has the capability to reach quickly and move throughout the depth and breadth of the battlefield. This mobility and flexibility aid the combined-arms commander in seizing or retaining the initiative (see Appendix B).

### **9-21. FBCB2-GENERATED FIRE MISSIONS**

Through synchronization of intelligence and fire support, tailored fire mission processing links can be established to expedite the engagement of selected high-payoff targets. Digitization gives the commander the ability to tailor fire mission threads better to meet a variety of needs. FBCB2 provides a basic call for fire (CFF) capability but does not currently link an FBCB2-equipped observer digitally to a fire support command and control node with AFATDS until the FBCB2 call for fire reaches the FBCB2-to-AFATDS jump point in the TF FSE. An observer can send an FBCB2 CFF directly to the TF FSE at the TOC, where it will automatically enter the AFATDS system. However,

this method can bypass both the commander or unit that the fires are intended to support and the fire support element designated to manage fires for the supported maneuver commander. It should be used only as a backup to the primary method discussed below.

a. **Primary CFF Procedure for the TF and Its Company Teams.** The norm for fire missions should be that they enter the AFATDS system at the lowest level possible so that the AFATDS system can apply the commander's guidance to the request for fire and the fire support elements at each level can manage the mission for the commander. Therefore, a CFF that originates at the platoon level should be sent to the company team FIST via FM voice. The FIST can quickly enter the fire mission into the AFATDS lightweight computer unit (AFATDS-LCU). The forward observer system (FOS) software enables an efficient entry into the AFATDS system so that FSOs in the fire support chain can manage the fires and apply the commander's guidance before the request is sent to the next echelon.

b. **Execution of Indirect Fires.** A well-developed scheme of fires establishes the specific task, purpose, method, and desired effects for all planned indirect fire missions, with the task, purpose, and effects tied to the scheme of maneuver. To be most effective, fire missions should be initiated based on specific enemy or friendly events. For example, obscuration and suppressive fires on a defending enemy should begin before the friendly unit comes within the direct fire range of the enemy to allow enough time for fires to become effective or adjusted before direct fire contact is made. The trigger to initiate these fires is based on the movement and positioning of some element of the task force. In this example, the indirect fires on the enemy position are initiated when the lead company team of the task force crosses a phase line, grid line, or some other designated point on the battlefield.

c. **Event-Driven Triggers and FBCB2.** Using event-driven triggers coupled with the friendly common operational picture allows the execution of the indirect fires to be tied to the scheme of maneuver effectively. Being able to watch the progress of the battle on the FBCB2 screen allows the indirect fire delivery unit to prepare to execute the mission and be ready to shoot as soon as the event trigger is reached. The executing unit should still make a final decision to execute the mission (has the situation changed so that the fires are no longer required or are they required somewhere else?) and transmit a call for fire.

d. **Event Triggers at End of Mission.** Event triggers can also be used to end a fire mission. For example, an obscuration mission is planned to screen the movement of a company team over an exposed piece of ground. Tracking the progress of the unit using FBCB2 not only tells the commander when to initiate the mission but also tells him when the unit has completed the movement or maneuver and possibly if the purpose of the mission has been accomplished.

e. **Asset Positioning and CFZs.** The common operational picture provided by FBCB2 can also be a valuable tool in managing both asset positioning and critical friendly zones. The FSE can track the location of the mortar platoon, supporting artillery assets, and observers as they maneuver across the battlefield. This information helps commanders and leaders make decisions on adjusting positioning and movement plans during execution. Being able to see (in near real time) where units are in relationship to the enemy, friendly maneuver units, and where they need to be to execute their assigned mission allows commanders to make timely decisions and fight the enemy and not the

plan. This visualization of the battlefield can also facilitate the execution of the counterfire battle through the management of CFZs. If entered in FBCB2 as an overlay, the planned CFZs can be displayed and compared to where the unit(s) they are designed to support are actually located. If the CFZ is not positioned correctly or the unit has moved, the task force FSE can quickly adjust the CFZ to the correct location.

f. **FBCB2 and FS Planning.** FBCB2 enables the FSE to disseminate critical information from the fire support plan rapidly down to each platform on the battlefield during top-down planning. A limitation, however, is that as targets and the plan are refined in AFATDS, they are not automatically updated in FBCB2. The FSO must closely control input into the FBCB2 fire support and airspace overlay to ensure they stay updated with all refinements. A technique is to use the FBCB2 overlays to disseminate information down and pass all the bottom-up refinements through AFATDS. Once the refinements are reviewed, approved, and entered into AFATDS, the FSO can create an updated overlay to disseminate back down. Keeping each system up-to-date affects the refinement cutoff time for bottom-up refinement. The FSE needs time to update both systems.

## **Section II. CLOSE AIR SUPPORT**

CAS is defined as air strikes on hostile surface forces that are in close proximity to friendly forces. CAS can be employed to blunt an enemy attack; to support the momentum of the ground attack; to help set conditions for task force and brigade operations as part of the brigade's overall counterfire fight; to disrupt, delay and destroy enemy second echelon forces and reserves; and to provide cover for friendly movements. CAS sorties are generally allocated to brigades only. For best results while avoiding mutual interference or fratricide, aircraft are kept under "detailed integration" (part of the Air Force's combat air system). The effectiveness of CAS is directly related to the degree of local air superiority attained. Until air superiority is achieved, competing demands between CAS and counterair operations may limit sorties apportioned for the CAS role. CAS is the primary support given to committed brigades and TFs by Air Force, Navy, and Marine aircraft. Brigades can request air reconnaissance and battlefield air interdiction missions through the division, but these missions are normally planned and executed at division level with the results provided to the brigade commander and his staff.

### **9-22. MISSIONS**

CAS is most often planned and controlled at the brigade level. However, this does not preclude the task force from requesting CAS, receiving immediate CAS during an operation, or being assigned execution responsibility for a brigade-planned CAS mission. CAS is another means of indirect fire support available to the brigade and task force. In planning CAS missions, the commander must understand the capabilities and limitations of close air support and synchronize CAS missions with both the task force fire plan and scheme of maneuver. CAS capabilities and limitations (windows for use, targets, observers, airspace coordination, and so on) present some unique challenges, but the commander and staff must plan CAS with maneuver the same way they do other indirect fires. Depending on the situation and availability of CAS assets, the task force may be allocated CAS missions or be assigned execution responsibility for a brigade CAS

mission. More likely, however, CAS can be handed off to the task force when the brigade has no viable target, or in response to the task force's request for immediate air support. If this happens, the task force must have a plan that synchronizes CAS with maneuver and the scheme of fires. The task force must also consider having the ETAC operate as an FAC in the observation plan.

a. **Preplanned Close Air Support.** Task force planners must forward CAS requests as soon as they can be forecast. These requests for CAS normally do not include detailed timing information because of the lead-time involved. Preplanned CAS requests involve any information about planned schemes of maneuver, even general information, that can be used in the apportionment, allocation, and distribution cycle. Estimates of weapons effects needed by percentage (for example, 60 percent antiarmor and 40 percent antipersonnel), sortie time flows, peak need times, and anticipated distribution patterns are vital to preparing the air tasking order. ALOs and S3s at all planning echelons must ensure that this information is forwarded through higher echelons in accordance with the air tasking order (ATO) cycle.

(1) **Categories.** Preplanned CAS may be categorized as follows:

(a) **Scheduled Mission.** This mission calls for aCAS strike on a planned target at a planned time.

(b) **Alert Mission.** This mission calls for a CAS strike on a planned target or target area to be executed when requested by the supported unit. This mission usually is launched from a ground alert (scramble), but it may be flown from an airborne alert status. Alert (on-call) CAS allows the ground commander to designate a general target area within which targets may need to be attacked. The ground commander designates a conditional period within which he later determines specific times for attacking the targets.

(2) **Request Channels.** There are specific request channels for preplanned CAS. Requests for preplanned tactical air support missions are submitted to the FSE. The commander, ALO, and S3 at each echelon evaluate the request; coordinate requirements such as airspace, fires, and intelligence; consolidate; and, if approved, assign a priority or precedence to the request. The S3 air then forwards approved requests to the next higher echelon. To plan CAS, the S3 air must work closely with the S3, FSO, and ALO.

(3) **Engagement Alternatives.** The CAS aircraft assigned to attack preplanned targets may be diverted to higher priority targets. For this reason, the FSO should plan options for the engagement of CAS targets by other FS assets.

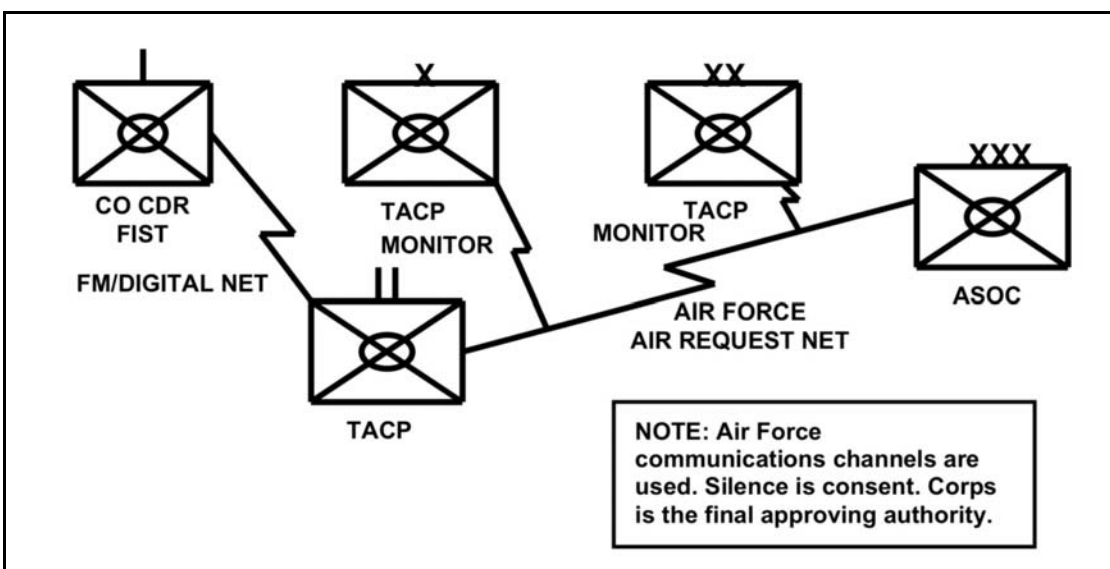
b. **Immediate Close Air Support.** Immediate requests are used for air support mission requirements identified too late to be included in the current air tasking order.

(1) Those requests initiated below battalion level are forwarded to the battalion task force command post by the most rapid means available. At battalion level, the commander, FSO, ALO, and S3 consider each request. Approved requests are transmitted by the TACP over the Air Force air request net (Figure 9-2, page 9-32) directly to the air support operations center (ASOC) collocated with the corps or separate division TOC. The TACP at each intermediate headquarters monitors and acknowledges receipt of the request. Silence by an intermediate TACP indicates approval by the associated headquarters unless disapproval is transmitted. The ASOC coordinates with the corps G3 air for all air support requests initiated by the corps. Meanwhile, intermediate TACPs



pass the request to the associated headquarters G3 or S3 for action and coordination. All echelons coordinate simultaneously.

(2) If any Army echelon above the initiating level disapproves a request or substitutes another support means (for example, Army aviation or field artillery), the TACP at that headquarters notifies the ASOC at corps and the originating TACP, which notifies the requester. When the corps commander or his representative approves the request, the ASOC initiates the necessary action to satisfy the request. If all distributed sorties are committed, the corps commander can request additional sorties from the next higher echelon, when appropriate. If the ASOC has no CAS missions available, it can, with Army concurrence, divert sorties from lower priority targets or request support from lateral or higher commands.



**Figure 9-2. Immediate close air request channels.**

### 9-23. PLANNING CONSIDERATIONS

CAS mission success directly relates to thorough mission planning based on the following factors and considerations. The S3 air is responsible for working with the task force ALO prior to and during TACAIR operations. Since there are no digital links with the TACP or supporting aircraft, he must consistently keep the ALO apprised of the ground tactical situation through digital and conventional means.

a. When operating in the task force's AO, CAS aircraft are under the positive control of one of the task force's TACP FACs. FACs monitor the ground tactical situation, review digital system information, and monitor conventional voice radio nets of the supported ground or maneuver commander to prevent fratricidal air-to-ground or ground-to-air engagements.

b. Other planning factors include time available for planning, C2 procedures, communications, and terrain.

### 9-24. AIR FORCE SUPPORT

Air Force units are attached to the TF to plan, control, and direct close air support. The ALO and the TACP are the typical air force assets attached to the TF.

a. **Air Liaison Officer.** ALOs are provided to Army maneuver units from corps to task force. The ALO is responsible for supervising the tactical air control party and coordinating close air support with the FSE and S3 air. The ALO is the senior USAF representative for the TACP supporting the task force. The ALO is normally located with the command group during tactical operations.

b. **Tactical Air Control Party.** TACPs are provided to Army maneuver unit headquarters at corps through battalion task force. TACPs provide direct interaction with the supported maneuver units and should be highly visible to Army commanders and readily available to assist in the integration and synchronization of air power with land-force fire and maneuver.

(1) The supported unit's ALO is the commander of the TACP. TACPs at corps through brigade function primarily in an advisory role. These sections provide Air Force operational expertise for the support of conventional Army planning and operations. They are the point of contact to coordinate local air defense and airspace management activities. Their function is specifically to assist Army planners in the preparation of the Army's plan to integrate CAS into the overall scheme of fires and maneuver. They coordinate preplanned and immediate air requests and assist in coordinating air support missions with appropriate Army airspace command and control elements. TF TACPs have the added responsibility of terminal attack control.

(2) TACPs coordinate activities through an Air Force air request net and the advanced airlift notification net. The TACP performs the following functions:

- Serves as the Air Force commander's representative, providing advice to the task force commander and staff on the capabilities, limitations, and employment of air support, airlift, and reconnaissance.
- Provides a coordination interface with respective FSE and A2C2 cells; assists in the synchronization of air and surface fires and preparation of the air support plan; and provides direct liaison for local air defense and airspace management activities.
- Integrates into the staff for air support planning for future operations and advises on the development and evaluation of CAS, interdiction, reconnaissance, and J-SEAD programs.
- Provides appropriate final attack control for CAS and operates the Air Force air request net.

(3) TACPs are manned at the following levels:

- *Corps:* One ALO, four fighter liaison officers (FLOs), two theater airlift liaison officers (TALOs), and six tactical air command and control specialists (TACCSs).
- *Division:* One ALO, three FLOs, three TALOs, and six TACCSs.
- *Brigade:* One ALO, one FLO, and four TACCSs.
- *Battalion Task Force:* One ALO and two TACCSs.

## 9-25. CLOSE AIR SUPPORT PLANNING DUTIES AND RESPONSIBILITIES

The ALO and members of the task force TACP provide the necessary expertise for the control and application of tactical air power. The ALO serves as the primary tactical air power advisor for the task force while TACP FACs provide final control for CAS missions executed in the task force's area of operations. Their collaborative working

relationship established with the brigades and maneuver TFs provides a working knowledge of ground operations and enhances their ability to integrate TACAIR operations with ground schemes of maneuver effectively.

a. **Forward Air Controller.** The primary responsibility of TACP FACs includes the positive control of CAS aircraft flying missions in support of brigade operations. Using their knowledge of ground operations, they are also better able to provide the troop safety necessary to avoid fratricidal engagements. The following paragraphs discuss FAC procedures and responsibilities.

(1) **Troop Safety.** The safety of ground forces is a major concern during day and night CAS operations. Fratricidal engagements are normally caused by the incorrect identification of friendly troops operating in an AO, or a failure to mark the boundaries of the friendly unit adequately. The use of proper authentication and ground marking procedures assures that a safe separation exists between the friendly forces and the impact area of aerial delivered munitions. Proper radio procedures and markings assist the FACs and the strike aircraft in the positive identification of ground forces and their operational boundaries.

(2) **Identification of Friendly Forces.** FBCB2 and the data it provides related to the disposition and location of friendly units enhances safety margins and reduces the potential of fratricidal engagements during joint air attack team or TACAIR operations. Friendly unit locations and boundaries can be marked using flash mirrors, marker panels, and direction and distance from prominent land features or target marks. Strobe lights are very good markers at night and in overcast conditions. They can be used with blue or infrared filters and can be made directional using any opaque tube. Any light that can be filtered or covered and uncovered can be used for signaling aircraft or marking friendly locations.

(3) **Target Acquisition.** Targets that are well camouflaged, small and stationary, or masked by hills or other natural terrain are difficult for fast-moving aircraft to detect. Marking rounds (rockets) fired from aerial platforms or artillery can enhance target acquisition and help ensure first-pass success.

(4) **Target Identification.** Strike aircraft must have a precise description of the target and know the location of friendly forces in relation to terrain features that are easily visible from the air. Airborne FACs are generally assigned an AO and become intimately familiar with its geographical features as well as the unit operating within the AO.

(5) **Final Attack Heading.** Choice of the final attack heading depends upon considerations of troop safety, aircraft survivability, enemy air defense locations, and optimum weapons effects. Missiles or bombs are effective from any angle. Cannons, however, are more effective against the sides and rears of armored vehicles.

b. **S3 Air.** The S3 air plans for and requests the use of CAS and attack helicopters to support the commander's concept of the operation.

c. **S2.** The S2 provides information on the avenues of approach, target array, terrain, and weather as it applies to the time and location of the JAAT operation. He also plans and coordinates the use of nonlethal attack assets to complement the JAAT.

d. **Attack Helicopter Liaison Officer.** The attack helicopter liaison officer performs the following tasks:

- Provides status of Army aviation assets available.
  - Begins planning the air corridors and air battle positions to support the operation.
  - Coordinates with the FSO and the ADO to deconflict air corridors.
  - Coordinates for the planned airspace coordination areas (ACAs).
- e. **Fire Support Officer.** The FSO performs the following tasks:
- Determines the need, availability, and positioning of artillery, commensurate with the enemy update, to support the JAAT.
  - Coordinates with the aviation representative to provide call signs and frequencies to the supporting FDC.
  - Helps the TACP deconflict the initial points from artillery positions and develop ACAs to support the mission.
  - Determines the need for SEAD.
  - Determines when and how priorities of fires shift.
  - Recommends FSCMs to enhance the success of the mission.
  - Establishes a quick fire channel if necessary.
- f. **Air Defense Officer.** The ADO performs the following duties:
- Coordinates to ensure that the ADA assets know the location of air corridors, battle positions, initial points, and ACAs.
  - Ensures these assets are informed of friendly air operations and their integration into the battle.
  - Advises the task force when to employ combined arms for air defense (CAFAD).
  - Passes directed early warning to task force.
  - Tracks the air battle.
  - Advise the task force on the use of passive and active ADA.
  - Establishes and maintains communications (operations and early warning) between the ADA battalion and task force.
  - Plans and coordinates use of airspace with the aviation officer.
- g. **Tactical Air Control Party.** The TACP performs the following duties:
- Develops contact points, initial points, and ACAs in coordination with the FSO and the ADO.
  - Disseminates contact points, initial points, and ACAs to the ASOC for dissemination to the ground liaison officer and wing operations center for preflight briefing.
  - Helps coordinate aircraft forward to the appropriate contact point or initial point and then hands them off to the aviation commander conducting the JAAT operation.

## 9-26. SUPPRESSION OF ENEMY AIR DEFENSE

SEAD operations target all known or suspected enemy ADA sites that cannot be avoided and that are capable of engaging friendly air assets and systems, including suppressive fires. The FSE integrates SEAD fires into an overall fire plan that focuses fires according to the commander's guidance. Synchronization of SEAD fires with the maneuver plan is accomplished using procedural control (an H-hour sequence), positive control (initiating

fires on each target as the lead aerial platforms pass a predetermined reference point or trigger), or a combination of the two. Regardless of the technique, the FSO planning the SEAD must conduct detailed planning and close coordination with the ALO, Army aviation LNO, S3 air, S2, ADO, FA battalion S3/fire direction officer (FDO), and FSE. Plans for SEAD operations are coordinated and synchronized over the tactical Internet (TI) using the AFATDS, ASAS-RWS, FBCB2, MCS, and aviation mission planning system (AMPS).

### **9-27. WEATHER**

Weather is one of the most important considerations when visually employing aerial-delivered weapons. Weather can hinder target acquisition and identification, degrade weapon accuracy and effectiveness, or negate employment of specific aerial munition types. The S3 air can request IMETS data from the division G2 to gain highly predictive and descriptive weather information for specific time periods and locations within the task force's AO. This data improves his ability to determine when close air support can be used. IMETS provides weather data based on inputs from the air weather services and meteorological sensors. This system is currently located at the division, but it interfaces with the ABCS systems and disseminates weather information down to maneuver TFs via the warfighter associate. It predicts weather effects on a specific mission, desired AO, or particular system. IMETS also provides weather hazards for different elevations, surface temperatures in a specific AO, and wind conditions. Meteorological satellite (METSAT) data may also be obtained to show regional cloud cover with high and low pressure systems annotated.

## **Section III. ENGINEERS**

Engineers perform essential engineer tasks to support task forces in executing mobility, countermobility, and survivability tasks. The task force uses engineers to shape the area of operations by providing freedom of maneuver for friendly forces, denying movement to the enemy, and protecting friendly forces from the effects of enemy weapon systems. Combat engineers must be fully integrated as part of the task force. Habitually, one engineer battalion supports an armor or infantry brigade combat team. Depending upon the mission, engineers will be further task-organized to the maneuver battalion task force as appropriate. When engineers are task-organized to the battalion, the senior engineer will act as the battalion staff engineer and assist the staff in planning and integrating engineers. Maneuver battalions not task-organized with engineers must still integrate the mobility, countermobility, and survivability BOS in their planning. For more specific information on engineer integration refer to FM 5-71-2.

### **9-28. BATTALION PLANNING FOR MANEUVER SUPPORT**

The battalion staff plans, integrates, and synchronizes mobility, countermobility, and survivability operations throughout the battalion's battlespace. In addition, the staff must coordinate all military and civilian engineer efforts within the battalion's area of operation. Details on staff engineer responsibilities can be found in FM 5-71-2.

a. **Mobility/Countermobility/Survivability Synchronization.** The battalion staff is responsible for ensuring that the BOS are integrated and synchronized within the battalion's plan. The staff synchronizes the plan and assists the commander in managing

its execution. The staff promotes synchronization by maintaining a common operational picture of all friendly and enemy engineer efforts in the area of operations. For specifics on combat engineer functions refer to FM 5-100.

(1) Mobility operations preserve friendly force freedom of maneuver. Mobility missions include breaching and clearing obstacles, maintaining battlefield circulation, providing assault or dry gap crossing, and identifying routes around contaminated areas.

(2) Countermobility denies mobility to enemy forces. It limits the maneuver of enemy forces and enhances the effectiveness of fires. Countermobility missions include obstacle building and smoke generation.

(3) Survivability operations protect friendly forces from the effects of enemy weapons systems and from natural occurrences. Hardening of facilities and fortification of battle positions are active survivability measures. Military deception, OPSEC, and dispersion can also increase survivability.

**b. Essential Mobility/Survivability Tasks.** An essential mobility/survivability task (EMST) is a specified or implied BOS-specific task that is critical to mission success. Ultimately, it allows the battalion task force's main effort to achieve its task and purpose. It may be accomplished directly in support of the main effort or one of its supporting efforts. Identification of the essential tasks helps to focus the development of plans, staff coordination, and allocation of resources. The staff, typically the maneuver support elements (engineer, chemical and military police staff officers) identify the essential mobility/survivability tasks. Failure to achieve an EMST may require the commander to alter his tactical or operational plan.

(1) A fully developed EMST has a task, purpose, method, and effects. The task describes what objective (breach, reduce, block, turn, fix, disrupt, clear, obscure) must be achieved to support friendly formations or what it will do to an enemy formation's function or capability. The purpose describes why the task contributes to maneuver and is nested with the maneuver task and purposes. The method describes how the task will be accomplished by assigning responsibility to maneuver units, supporting units, or delivery assets and by providing amplifying information or restrictions. The effect is the general narrative of what the commander wants to happen.

(2) The approved EMSTs are described in the concept of operations paragraph within the base order. The concept of operations includes the logical sequence of EMSTs that, when integrated with the scheme of maneuver, will accomplish the mission and achieve the commander's intent. The scheme of engineer operations describes the detailed, logical sequence of all mobility, countermobility, survivability operations; general engineer tasks; decontamination, smoke, and geospatial engineering tasks; and their impact on friendly and enemy units. It details how the engineers expect to execute the BOS plan to accomplish the commander's EMSTs.

**c. Task Organization of Engineers.** Engineer units serve two roles in the battalion task force. The first and most important role is as a force enabler. In this role, the engineer unit resources maneuver units with engineer assets to enable them to accomplish their assigned tasks. The second role is that of a force provider. In this role the engineer unit executes assigned tasks within the framework of the scheme of operations. Clearly identifying the EMSTs across the width and depth of the battlefield will drive the logical task organization of mobility/survivability assets. Engineers execute essential unit tasks to support the accomplishment of essential mobility/countermobility/survivability tasks.

Engineer elements should be task-organized because an EMST dictates an essential unit task. If a maneuver unit does not have a specified EMST that requires engineer support, then the engineer element should be under the control of its higher headquarters or massed to accomplish EMSTs elsewhere in the brigade's AO.

### **9-29. MOBILITY**

At the tactical level, superior mobility is critical to the success of the force. Mobility facilitates the momentum and freedom of movement and maneuver of forces by reducing or negating the effects of existing or reinforcing obstacles. Within this context, the emphasis of engineer integration is on mobility operations. Due to the full-spectrum capability of a battalion task force and the nonlinear, asymmetric nature of the threat, the potential exists for the force to encounter a wide variety of existing and reinforcing obstacles. To counter this potential, the commander, staff, and task-organized engineers plan, organize, and prepare to perform mobility tasks using the full range of organic and augmentation mobility assets. These mobility tasks include combined arms route clearance, combined arms breaching, and maintaining area mobility.

a. **Route Clearance.** Route clearance is a combined arms operation typically executed by a maneuver company or battalion. Engineers reduce or clear obstacles as part of a route clearance mission. Units must clear lines of communication of obstacles and enemy activity that disrupt battlespace circulation. Units must conduct route clearance to ensure that LOCs enable safe passage of combat, combat-support, and CSS organizations. Clearance operations are normally conducted in a low threat environment. The significant difference between breaching and clearing operations is that breaching usually occurs during an attack (while under enemy fire) to project combat power to the far side of an obstacle. Route clearance focuses on opening LOCs to ensure the safe passage of combat and support organizations within an AO. Details on route clearance are covered in FM 3-34.2.

b. **Combined Arms Breaching.** Engineers reduce lanes in obstacles as part of a combined arms breaching operation. Because of the potentially asymmetrical, nonlinear nature of operations, engineers must be prepared to perform mounted and dismounted reduction tasks using manual, mechanical, and explosive reduction means. Through reverse breach planning, the staff identifies critical mobility tasks, allocates reduction assets, and determines the breach organization (support, assault, and breach force). Keys to allocating reduction assets include identifying all reduction tasks within the AO, matching specific reduction assets to each task, and planning 50-percent redundancy in reduction assets for each task. For more specific information on combined arms breaching, refer to FM 3-34.2.

c. **Area Mobility.** Generating and sustaining combat power requires the battalion to maintain area mobility. Area mobility operations include clearing unexploded ordnance, clearing residual minefields, tracking dirty battlefield effects, and MSR repair and maintenance. Limited organic assets necessitate augmentation to preserve area mobility. The battalion staff identifies shortfalls in capability and coordinates with the brigade to request additional assets.

---

### **9-30. COUNTERMOBILITY**

Countermobility is the augmentation of natural or manmade terrain (urban) with obstacle systems and integrated with direct and or indirect fire systems to disrupt, fix, turn, or block the enemy while the maneuver commander destroys their combat capabilities with increased time for target acquisition. The commander and staff integrate obstacles within the maneuver plan, enforcing adherence to obstacle emplacement authority and obstacle control measures. Task-organized engineers construct conventional minefields, ground emplaced scatterable minefields, special munitions, and explosive and non-explosive obstacles in support of the scheme of maneuver. (FM 5-102 is the primary reference for countermobility planning.)

### **9-31. SURVIVABILITY**

Survivability encompasses the development and construction of protective positions such as earth berms, dug-in positions, and overhead protection as a means to mitigate the effectiveness of enemy weapon systems. Significant survivability efforts will require engineer augmentation. The staff must plan and prioritize survivability efforts. The plan should specify the level of survivability for each battle position and the sequence in which it receives support (if available). Additional considerations for survivability planning include command and control of digging assets, site security (including air defense coverage), CSS (fuel, maintenance, and Class I), and movement times between BPs. (FM 3-34.112 is the primary reference for survivability planning.)

### **9-32. GENERAL ENGINEERING**

General engineering encompasses those tasks that establish and maintain infrastructure that is required for conducting and sustaining military operations. Such tasks include construction and repair of lines of communication, main supply routes, airfields, utilities, and logistical facilities. Due to the organization of the engineer company, general engineering tasks will require augmentation from outside the brigade. (FM 5-104 is the primary reference for general engineering planning.)

### **9-33. GEOSPATIAL ENGINEERING**

Geospatial engineering is the collection, development, dissemination, and analysis of positionally accurate terrain information that is tied to some earth reference to provide mission tailored data, tactical decision aids, and visualization products that define the character of the AO for the maneuver commander. The staff should identify required tactical decision aids and coordinate with brigade for the necessary products. Products commonly provided include common map backgrounds, line of sight analysis, cross-country mobility overlays, artillery slope overlays, and specialized imagery products. (FM 3-34.230 is the primary reference for geospatial engineering planning.)

### **9-34. ENGINEER BATTALION**

The engineer battalion consists of three line combat engineer companies and a headquarters and headquarters company. The engineer battalion can provide support simultaneously to three maneuver task forces; it is not structured to provide continuous, dedicated support to other units. The engineer battalion can receive additional engineers from echelons above division for increased obstacle reduction and creation capability,



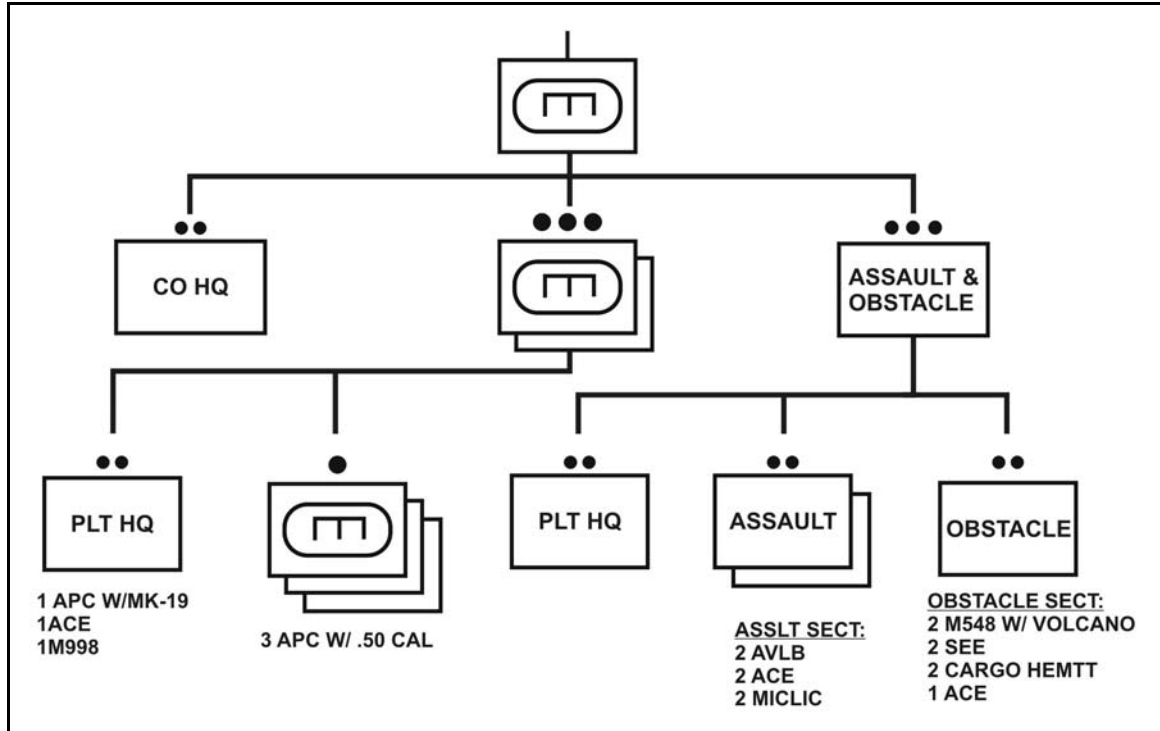
deliberate defensive operations, operations in restricted terrain, LOC construction, and maintenance and repair of bridges. This level of support may be increased based on METT-TC and the battalion's priority within the brigade scheme of maneuver. Corps-level support may consist of a company from a corps combat battalion (mechanized or wheeled), a platoon from a combat support engineer (CSE) company, or a horizontal construction platoon from a combat-heavy company provided in DS for specified times or tasks.

### **9-35. ENGINEER COMPANY**

Maneuver task forces typically receive a mechanized engineer company in either an attached, OPCON, or direct support relationship during both offensive and defensive operations. Based on the task force's mission and the overall brigade plan, the task force may receive a variation of the engineer company with either increased or reduced assets. The engineer company is the lowest engineer echelon that can plan and execute continuous 24-hour operations in support of the maneuver force. The engineer company is ideally suited for integration into task force operations. It is an agile organization that enables freedom of maneuver on the battlefield within the combined arms team framework. Its structure and operational characteristics enhance force momentum and lethality and increase the synchronization of engineer actions within the task force's battlespace.

a. **Mission.** The mechanized engineer company conducts engineer battlefield functions for the task force, focusing on mobility, countermobility, and survivability tasks. As a combat multiplier, the engineer concentrates his efforts on maintaining the task force's freedom of maneuver and lessening the enemy's ability to mass and maneuver on the battlefield. Combat engineers shape terrain and create obstacles to enhance the battle effectiveness of fire and maneuver. Their efforts are designed to support forward fights.

b. **Organization.** The division engineer company consists of a company headquarters, two combat engineer platoons, and an assault and obstacle (A&O) platoon (Figure 9-3). The company can be organized to operate as an engineer-pure element, or it can receive a cross-attached tank or infantry platoon. The company headquarters includes the commander, the operations officer or XO, the first sergeant, an operations NCO, a supply sergeant, an NBC sergeant, and a communications specialist or NCO. The company headquarters commands and controls the unit's tactical employment and administrative operations. The engineer company CP can be integrated as an element of the task force main CP. The engineer company XO and operations NCO provide continuous integration and synchronization of engineers to the battle staff while the company commander advises the task force commander.



**Figure 9-3. Combat engineer company.**

### 9-36. COMBAT ENGINEER (SAPPER) PLATOON

The combat engineer platoon is normally the lowest level engineer unit that can effectively accomplish independent missions and tasks. It is a basic unit capable of maneuvering during combat operations, and it can fight as part of the engineer company or as part of a maneuver company team. The combat engineer platoon consists of a platoon headquarters section and three engineer squads (Figure 9-3). On the battlefield, the combat engineer platoon can expect rapid and frequent movement. It prepares to fight both mounted and dismounted during various situations. The combat engineer platoon frequently receives augmentation in the form of special equipment from the A&O platoon. Engineer squads can be task-organized for special missions of limited duration such as engineer reconnaissance missions. Task-organizing below platoon level degrades the engineer platoon leader's ability to mass critical engineer assets during operations. Each sapper platoon is allocated two MICLIC trailers which may be pulled by squad vehicles based upon engineer company SOPs.

### 9-37. ASSAULT AND OBSTACLE PLATOON

The A&O platoon is a unique element that contains specialized engineer heavy equipment to support mobility, countermobility, and survivability tasks in support of the maneuver task force. The platoon consists of a platoon headquarters section, two assault sections, and an obstacle section (Figure 9-3). The A&O platoon is not organized to operate independently like the combat engineer platoons. It provides the task force commander with specialized equipment to conduct both offensive and defensive operations based upon METT-TC. Normally, the A&O platoon is responsible for survivability position construction, specialized equipment control, and flank obstacles

using the ground Volcano systems. The platoon normally operates in one of the following roles:

- Supported by a combat engineer platoon.
- In task-organized sections in support of the engineer platoon or company.
- Task-organized to a maneuver company team within the task force.

a. **Assault Sections.** The assault sections are structured for mobility missions focusing on reducing enemy complex obstacles and fortifications that inhibit friendly maneuver. Each assault section contains two armored vehicle-launched bridges (AVLBs) or Wolverines, two armored combat earthmovers (ACEs), and two mine clearing line charges. Each is capable of reducing a variety of natural and manmade obstacles such as minefields, gaps, and berms. A section sergeant provides C2 for these sections and maintains communications with both the section's individual vehicles and the support maneuver unit.

b. **Obstacle Section.** The obstacle section is structured to focus on reinforcing terrain with obstacles to attack the enemy's ability to maneuver. The section consists of two M548s (which carry the Volcano mine-laying system) and two heavy expanded mobility tactical trucks (HEMTTs). A section sergeant is responsible for C2 of the obstacle sections and provides liaison with the supported maneuver unit.

### 9-38. ENGINEER ASSETS

The engineer assets that may be available for supporting the TF include organic engineer equipment, Volcano, modular pack mine systems (MOPMS), family of scatterable mines, and the hand emplaced Raptor. These assets are discussed below.

a. **Organic Combat Engineer Company Equipment.** The engineer company supporting the task force normally has the following organic equipment.

(1) **Armored Vehicle Launched Bridge.** The AVLB is an M60-series or M48-series tank chassis modified to transport, launch, and retrieve an 18-meter (60-foot) bridge. The span is capable of carrying military load classification (MLC) 60 track loads across a 17-meter gap and MLC 70 loads across a 15-meter gap. The Wolverine heavy assault bridge will eventually replace the AVLB. The Wolverine is capable of spanning a 24-meter gap carrying an MLC of 70.

(2) **Mine-Clearing Line Charge.** The MICLIC is a rocket-propelled explosive line charge. When fired into a minefield, it can create a lane that is 100 meters long and 14 meters wide. The MICLIC is either trailer-mounted or carried on the AVLM. The trailer can be towed behind an M113 APC, M-2 Bradley, or M9 ACE. The MICLIC is most effective against surface-laid AT and antipersonnel (AP) mines. It has limited effect against buried mines. A mechanical or dismantled proof of the reduction lane is required due to the skip zone.

(3) **Armored Vehicle-Launched MICLIC (AVLM).** This vehicle serves as a launch platform for two MICLICs. The AVLM is a modified AVLB chassis with the bridge downloaded and two MICLIC launchers mounted on a modified frame secured to the rear deck. The AVLM provides better mobility, crew protection, and responsiveness than the trailer-mounted MICLIC. The AVLM can breach two lanes in a minefield under 100 meters deep and one lane in a minefield 187 meters deep or less.

(4) **Armored Combat Earthmover.** The M9 ACE, with its front-end blade and rear-end winch, can travel at 30 mph and is primarily designed to provide responsive

earthmoving capability during mobility operations. It is capable of filling crater and antitank ditches, removing rubble and debris from roads and trails, and reducing (skimming) surface-laid minefields during offensive operations (however it is slower and substantially less survivable than a tank plow or roller). In the defense, its primary purpose is to construct hasty vehicle fighting positions. It can also assist attached dozers in constructing antitank ditches and hull- or turret-depth vehicle fighting positions.

(5) **Small Emplacement Excavator.** The small emplacement excavator (SEE) is an all-purpose wheeled engineer vehicle that can be configured with a variety of interchangeable tools like a backhoe and a front-end loader. The SEE provides forward combat troops with the capability to support units by digging individual fighting positions, bunkers, command posts, and other positions for combat equipment.

b. **Scatterable Mines.** Scatterable mines are remotely delivered or dispensed by aircraft, artillery, missile, or ground dispensers and laid without pattern. All US SCATMINES have a limited active life and self-destruct (SD) after that life has expired. The duration of the active life varies with the type of delivery system and mine.

(1) SCATMINES, with their flexibility and rapid emplacement capabilities, provide the commander with a means to respond to a changing enemy situation. They enable the commander to emplace minefields rapidly in enemy-held territories, contaminated territories, and other areas where it is impossible for engineers to emplace conventional minefields. Some systems allow for rapid emplacement of minefields in friendly areas.

(2) During the war gaming process, the engineer--in conjunction with S3, S2, and FSO--identifies the requirement to respond to an enemy action with SCATMINES. He then determines the minefield location, size, density, emplacement and SD times, delivery method, and the trigger (decision point) for execution.

### 9-39. SCATMINE CAPABILITIES

SCATMINES can be emplaced more rapidly than conventional mines, so they provide a commander with greater flexibility and more time to react to changes in situations. The commander can use SCATMINES to maintain or regain the initiative by acting faster than the enemy. Using SCATMINES also helps preserve countermobility resources that can be used to conduct other operations on the battlefield. With the reduction in the size of divisional engineer units, SCATMINES are increasingly important.

a. **Remote Placement.** All SCATMINES are rapidly emplaced. This enhances battlefield agility and allows the maneuver commander to emplace mines to best exploit enemy weaknesses. SCATMINES can be used as tactical or protective obstacles. When used tactically they attack enemy formations directly through disrupt, fix, turn, and block obstacles. As tactical obstacles they can be either directed or situational. Modern fusing, sensing, and antihandling devices (AHDs) improve the ability of SCATMINES to defeat enemy attempts to reduce the minefield.

b. **Increased Tactical Flexibility.** Upon expiration of the SD time, the minefield is cleared by self-detonation and the commander can move through an area that was previously denied to enemy or friendly forces. In many cases, the SD period may be set at only a few hours. This feature allows for effective counterattacks to the enemy's flank and rear areas. Table 9-2, page 9-44, defines when certain mines begin self-destruction and when destruction is complete.

SD Time	SD Window Begins
4 hours	3 hours 12 minutes
48 hours	38 hours 24 minutes
5 days	4 days
15 days	12 days

**Table 9-2. Self-destruct windows.**

c. **Efficiency.** SCATMINES can be emplaced by a variety of delivery methods. Fixed-wing aircraft, helicopters, artillery, manpack, or ground vehicles can deploy them. They satisfy the high mobility requirements of modern warfare and reduce manpower, equipment, and tonnage requirements with their emplacement.

d. **Increased Lethality.** SCATMINES use an explosive technique that produces a full-width kill. The effect produces a mobility kill against a vehicle's engine, track, or drive-train, or it produces a catastrophic kill by setting off the onboard ammunition, killing or incapacitating the crew, or destroying the vehicle's weapons systems. SCATMINES are designed to destroy any tank currently available.

#### **9-40. SCATMINE LIMITATIONS**

The following are limitations of SCATMINES:

a. **Extensive Coordination.** Because SCATMINES are a very dynamic weapon system, proper coordination with higher, adjacent, and subordinate units is extremely important. To prevent friendly casualties, all affected units must be notified of the location and the duration of scatterable minefields.

b. **Proliferation of Targets.** SCATMINES are regarded by some commanders as easy solutions to tactical problems. Target requests must be carefully evaluated, and a priority system must be established because indiscriminate use of weapons systems results in rapid depletion of a unit's basic load. Controlled supply rates (CSRs) are likely to be a constraint in all theaters.

c. **Visibility.** SCATMINES are highly effective, especially when fires and obscurants strain the enemy's C2. SCATMINES lay on the surface of the ground, but they are relatively small and have natural coloring.

d. **Accuracy.** SCATMINES cannot be laid with the same accuracy as conventionally emplaced mines. Remotely delivered SCATMINE systems are as accurate as conventional artillery-delivered or tactical aircraft-delivered munitions.

e. **Orientation.** Between 5 and 15 percent of SCATMINES come to rest on their edges. Mines with spring fingers are in the lower percentile, and mines landing in mud or snow more than 10 centimeters deep are in the higher percentile. When employing ADAMs or RAAMs in more than 10 centimeters of snow or mud, use high-angle fire and increase the number of mines. Snow melt may also cause the mines to change positions and activate AHDs.

f. **Lethality and Density.** Scatterable minefields are employed to reduce the enemy's ability to maneuver, mass, and reinforce against friendly forces. They increase the enemy's vulnerability to fires by producing specific obstacle effects (disrupt, fix, turn, or block) on the enemy's maneuver (Table 9-3). To achieve this effect, individual minefields must be emplaced with varying degrees of lethality. Changing the minefield density is a primary way to vary lethality and the effect. If the obstacle is not resourced or insufficient density is achieved, the planned lethality will not be achieved. There is a

direct correlation between the obstacle effect and the minefield density. In order to achieve the tactical-obstacle effect, use the guidance in Table 9-3 when selecting minefield density.

<b>Disrupt</b>	<b>Turn</b>
Low density. Probability of encounter: 40 to 50 percent. Linear density: 0.4 to 0.5 mine per meter.	High density. Probability of encounter: 75 to 85 percent. Linear density: 0.9 to 1.1 mines per meter.
<b>Fix</b>	<b>Block</b>
Medium density. Probability of encounter: 50 to 60 percent. Linear density: 0.5 to 0.6 mines per meter.	High density. Probability of encounter: 85+ percent. Linear density: More than 1.1 mines per meter.

**Table 9-3. Lethality and density.**

**9-41. COMMAND AND CONTROL OF SCATMINES**

Due to the delivery means, C2 of SCATMINES is more complex than with conventional mines. SCATMINES are very dynamic weapons systems because they can be rapidly emplaced and then cleared by way of their SD capability. In addition, the physical boundary of a scatterable minefield is not clearly defined. These characteristics require impeccable communications and coordination to ensure that all friendly units know where mines are located, when they will be effective, and when they will self-destruct.

a. **Emplacement Authority.** The corps commander has emplacement authority for all scatterable minefields within the corps AO. He may delegate this authority to lower echelons according to the guidelines in Table 9-4, page 9-46. Based on how the commander wants to shape the battlefield, he must specifically delegate or withhold the authority to employ SCATMINE systems. The commander's guidance concerning SCATMINES is found in the unit's OPORD or OPLAN. Additional information is included in engineer and fire-support annexes, if used.

System	Emplacement
Ground or artillery-delivered, with SD time greater than 48 hours (long duration).	The Corps commander may delegate emplacement authority to division level, who may further delegate to brigade level.
Ground or artillery-delivered, with SD time of 48 hours or less (short duration)	The corps commander may delegate emplacement authority to division level, who may further delegate it to brigade level, who may further delegate to BN level.
Aircraft-delivered (Gator), regardless of SD time.	Emplacement authority is normally at corps, theater, or army command level, depending on who has air-tasking authority.
Helicopter-delivered (Volcano), regardless of SD time.	Emplacement authority is normally delegated no lower than the commander who has command authority over the emplacing aircraft.
MOPMS when used strictly for a protective minefield.	Emplacement authority is usually granted to the company or base commander. Commanders at higher levels restrict MOPMS use only as necessary to support their operations.

**Table 9-4. Emplacement authority.**

b. **Coordination.** The fire support officer is involved in planning artillery-delivered (ADAM and RAAM) SCATMINES, and the air liaison officer is involved in planning air-delivered (Gator) SCATMINES. The engineer has primary responsibility for planning and employing SCATMINE systems. It is vital that coordination be conducted with all units and subunits that will be affected by the employment of SCATMINES. A scatterable minefield warning (SCATMINWARN) is sent to all affected units before the emplacement of the minefield.

#### **Section IV. AIR DEFENSE SUPPORT**

Early engagement of enemy aircraft is one of the most important short-range air defense (SHORAD) employment guidelines. Air attack information is received and processed by the forward located Sentinel elements and air battle management operations center (ABMOC). External and internal air track information is correlated by the Sentinel and forward area air defense command, control, comuters, and intelligence (FAADC3I) and subsequently transmitted to the handheld terminal unit (HTU) of the firing units (FUs) and the brigade's FAADC3I managed SHORAD. The FAADC3I manages engagement operations, which involves taking sensing data from organic, Patriot, and joint sensors and passing this information to the SHORAD weapons for engagement. The air and missile defense workstation (AMDWS) manages force operations, which involves managing SHORAD assets by knowing the status, location, and posture of all assets in relation to the brigade maneuver plan. This ensures that they can be properly supported and sustained and can provide the best coverage for the supported brigade. This information is subsequently transmitted to subordinate units via FFCB2, if equipped;

otherwise, the units use enhanced position location reporting system (EPLRS) and frequency modulated (FM) systems (Figure 9-4).

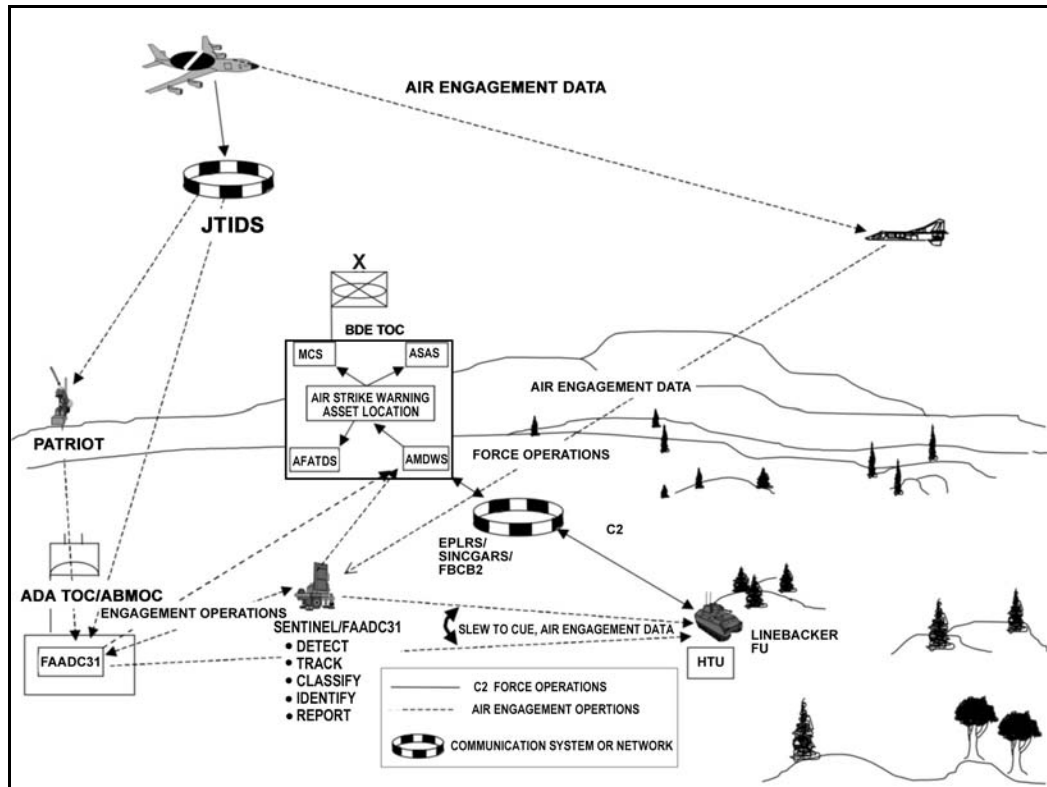


Figure 9-4. Air defense artillery architecture.

**9-42. MISSION**

Air defense artillery cruise missiles protect the force and selected assets from aerial attack and surveillance. The primary aerial threats that must be countered by SHORAD systems are UAVs, rotary-wing aircraft, and fixed-wing aircraft.

**9-43. ORGANIZATIONS**

The brigade is typically supported by an ADA battery (Figure 9-5, page 9-48). A task force is typically supported by a Linebacker platoon, consisting of four firing units and a C2 vehicle. The platoon is organized into a headquarters section and two maneuver sections. Air defense commanders may modify platoon organizations to fit specific mission requirements. The platoon may operate in a role DS to the task force but is more commonly in a GS role under control of the ADA battery commander.



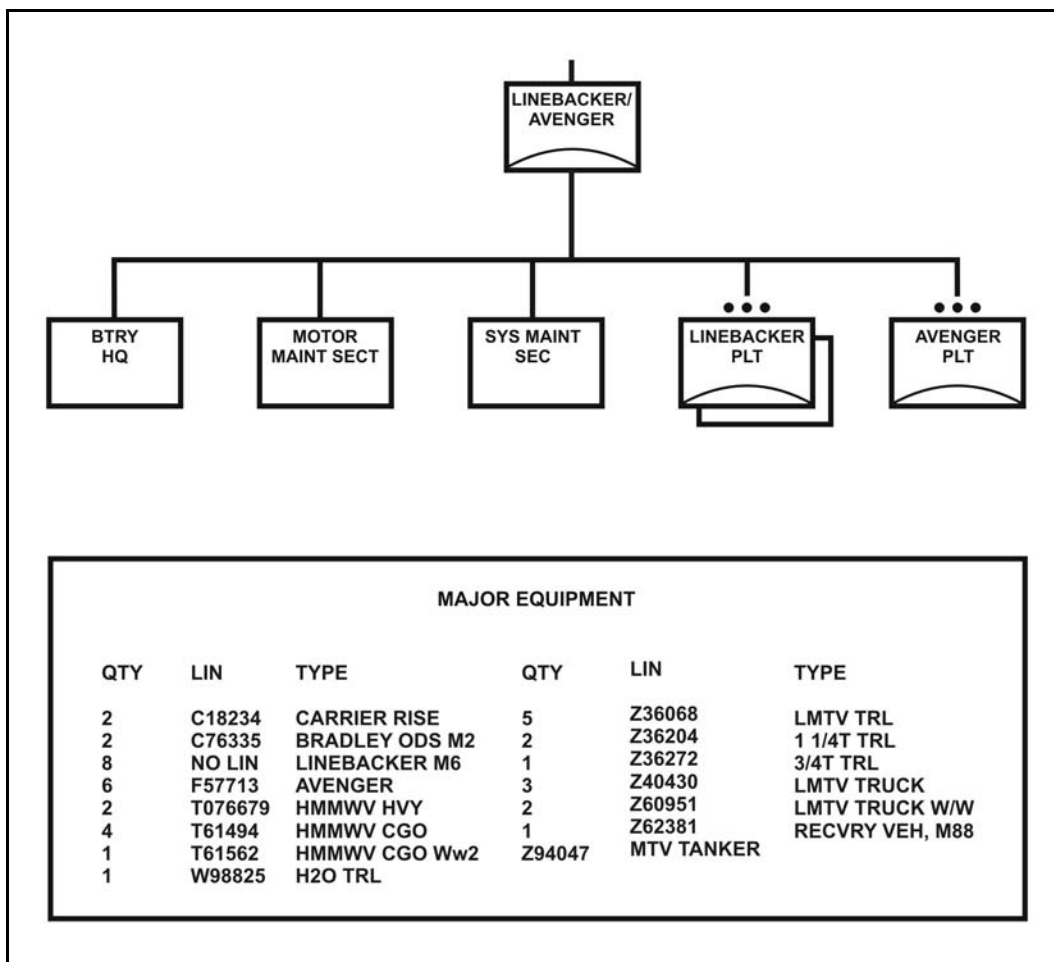


Figure 9-5. Air defense artillery battery.

**9-44. AIR DEFENSE PLANNING CONSIDERATIONS**

The task force commander and his ADO integrate the firepower of all available fire systems to defeat the enemy air threat.

a. ADA employment guidelines are used as aids for positioning individual ADA firing units. There are six ADA employment guidelines.

(1) **Early Engagement.** Firing units must be positioned where they can engage enemy air platforms before the enemy can release his ordnance on or gain intelligence about friendly forces. With the mobility provided by the Linebacker, firing units should be located well forward and integrated into the supported task force’s scheme of maneuver. In less likely missions of defending a static asset, firing units should be positioned forward of the supported force along likely enemy air avenues of approach.

(2) **Weighted Coverage.** Once the supported force commander designates his main effort, Linebacker firing units should be positioned along the most likely air avenues of approach to support the commander’s main effort. This massing of firepower increases the Linebacker platoon’s probability of killing enemy air targets. It is extremely important that detailed, in-depth air IPB is developed prior to deciding where to weight coverage of air defense assets. Air defense focuses its efforts on the most likely avenues of approach along the supported force commander’s designated main effort.

(3) **Depth.** Depth is achieved by positioning firing units so enemy air platforms encounter a continuous volume of fire as they approach the protected force or asset. The Linebacker platoon leader achieves depth by positioning his assets so that they can provide continuous fires along enemy air avenues, destroying the enemy as it advances toward the protected force or asset. Depth is maximized through the integration of all air defense weapons. Additional air defense assets on the battlefield (such as Stinger teams, Avenger firing units, high- to medium-altitude air defense (HIMAD) assets, and combined arms air defense efforts from ground forces) contribute to the creation of depth on the battlefield.

(4) **Balanced Fires.** Positioning air defense weapons to distribute fire equally in all directions creates balanced fires. Except for the mission of defense of a static asset where no clear avenues of approach are identified, this guidance is seldom employed. As an example, on a flat, open battlefield characteristic of some desert environments, no specific air corridor exists. In this situation, planning for balanced fires may be viable.

(5) **Mutual Support.** Mutual support is achieved by positioning weapons to complement fires from adjacent firing units, thus preventing the enemy from attacking one position without being subjected to fire from one or more adjacent positions. Mutual support enhances volume of fire and covers the dead space of adjacent units. The planning range for mutual support for Stinger systems is approximately 2,000 meters.

(6) **Overlapping Fires.** Because of the task force's extended battlespace and a scarcity of available Stinger systems, the air defense planner should attempt to enhance air defense protection by positioning firing units so that engagement envelopes overlap. The planning range for overlapping fires for Stinger systems is approximately 4,000 meters.

b. The FAADC3I system greatly enhances the ADO's ability to use these guidelines. The greatest impact is on early engagement. Air defense firing units must be positioned so that they are capable of engaging enemy aircraft prior to the ordnance release line (ORL). The determination of enemy air avenues of approach and ordnance loads comes from the air IPB. The HTU enhances early warning and engagement and is issued to all ADA firing units including the ADA platoon leaders. It enables the firing units to receive early warning (40 kilometers out) air tracks (data) from the sensor, which in turn receives external air tracks (data) from the ABMOC. The sensor correlates external (ABMOC) track data with its own local data and broadcasts that data to its air defense battery, platoons, sections, firing units, and brigade air defense LNOs. The TF and direct support air defense firing units still broadcast flash precedence "FM voice" early warning to maneuver elements.

c. The additional feature of early warning distance (from enemy aircraft to the air defense firing unit) is enhanced by the fact that the HTU enables the air defense firing unit to see 360 degrees out under ideal situations (20 kilometers light and special divisions interim sensor [LSDIS] and 40 kilometers ground-based sensor [GBS]). ADA must still be attentive and suspect those areas where a pop-up or masked area (blind spot between the HTU at the firing unit or platoon CP and the sensor) might exist and allow the enemy to reach those locations undetected.

d. Linebackers normally accompany the main body or the task force reserve. Ultimately, Linebacker positioning is determined by the factors of METT-TC, the IPB, and the task force commander's priorities. The Linebacker platoon may be task-organized

to provide direct support to the task force or task-organized into sections to support individual company teams. In either case, the task force ADO must retain the flexibility to mass ADA assets at the critical time and place them on the battlefield to defeat the air threat. FAADC3I allows the ADO to push assets out to a broader area of coverage to provide more firepower forward, facilitate earlier engagement, and cover the flanks.

#### **9-45. AIR DEFENSE OFFICER DUTIES**

The task force ADO has dual responsibility as the ADO and ADA platoon leader. The ADO must participate in the MDMP as an integral member of the task force staff. The ADO should work closely with the S2 during the IPB process and is best suited to prepare and brief the air IPB. Airspace or the aerial dimension of the battlefield is the most dynamic and fast-paced of the three dimensions. The most significant threats that must be evaluated at the task force level for aerial IPB are UAVs, fixed-wing aircraft, and rotary-wing aircraft.

a. The ADO's mission analysis should cover the following areas:

- Air threat overview: air avenues of approach, type of air threat, probable threat objective, and potential to support the maneuver forces.
- Specified, implied, and essential tasks: from the air defense perspective (for example, early warning).
- Constraints and restrictions: initial air defense warning status, weapons control status, and systems limitations.
- Forces available: SHORAD, HIMAD, and sensor coverage.
- Platoon status: personnel, maintenance posture, weapons status, and missile supply.
- Issues: coordination with brigade (for example, missile supply).

b. The ADO also performs the following duties:

- (1) Assists the S3 in planning and executing the air defense portion of the operation.
- (2) Advises the commander and S3 on the employment of air defense assets.
- (3) Coordinates with the S3 air, FSO, and FAC for the appropriate air defense posture and A2C2.
- (4) Controls integration of air defense elements and early warning systems.
- (5) Recommends priorities to the commander:
  - (a) *Threat*: Reverse target value analysis.
  - (b) *Criticality*: Force or asset that is essential to mission accomplishment.
  - (c) *Vulnerability*: Susceptibility to surveillance and attack.
  - (d) *Recouperability*: In terms of time and equipment.

c. The ADO is also responsible for the execution of the air defense plan. He must monitor the positioning and coverage provided by his platoon and other ADA assets, recommending changes to the plan based on the enemy threat and changes in the scheme of maneuver. FBCB2 allows the ADO to track his platoon assets visually to ensure proper position and coverage for the protected force. In most situations, the information provided by FBCB2 allows the supporting ADA platoon to perform a general support mission to the task force rather than task-organizing the platoon to the maneuver company teams. This allows the ADO to command and control the supporting ADA assets and frees subordinate company team commanders of this requirement.

**9-46. OFFENSIVE CONSIDERATIONS**

In offensive operations, air defense units move so they are best positioned to protect the supported force. Consider weighting the main effort. The air defense plan must support the supported commander's scheme of maneuver. Air defense priorities are established to ensure effective and continuous support for the offensive operation. BSFVs or Linebackers normally accompany the main body or task force reserve but ultimately BSFV or Linebacker positioning is determined by the factors of METT-TC. The BSFV or Linebacker platoon normally provides direct support coverage to the task force. Priorities for protection may include maneuver elements, fire support, engineer elements, command and control nodes, and logistics assets. Unit SOP and mission-specific IPB developed during the planning process determine priorities for air defense for each mission.

**9-47. DEFENSIVE CONSIDERATIONS**

The air defense plan must address air defense coverage during all phases of the defense. The number one challenge to the Linebacker platoon is to deny the enemy's use of reconnaissance, surveillance, and target acquisition (RSTA) air assets. SHORAD assets focus on the main air avenues of approach. Lateral coordination with adjacent units is required to preclude gaps in the defense. The 25-mm automatic gun and 7.62-mm coaxial machine gun should be used against ground targets for self-defense. Normally in a counterattack, Linebackers travel with the counterattack force or operate from overwatch positions to protect the counterattack force from enemy aerial platforms.

**9-48. AIR DEFENSE TYPES**

The TF adopts its air defense posture based on the type of supporting ADA assets it has attached. The TF always uses a combination of active and passive measures to protect itself against air attack.

a. **Active Air Defense.** Active air defense is direct action taken by all weapons platforms to destroy enemy aircraft or reduce their effectiveness in the delivery of aerial munitions or forces. For example, a large volume of fire from small arms (M16, M249, and caliber .50) can destroy attacking aircraft or disrupt their attack. Tank main guns and Bradley 25-mm guns can also engage attacking aircraft effectively. Specifically, the proximity fuze in the M830A1 multi-purpose AT round can sense an air target and cause detonation as the round nears the aircraft. (See general rules for engaging aircraft in FM 44-8.)

b. **Passive Air Defense.** There are two types of passive air defense measures: cover and concealment and damage limiting. Cover and concealment is used to avoid being detected by the enemy. Damage-limiting measures are those taken to avoid damage from air attack, such as vehicle dispersion, camouflage, and dug-in fighting positions with overhead protection.

**9-49. AIR DEFENSE WARNINGS AND WEAPONS CONTROL STATUS**

TF leaders should ensure their subordinates understand the air threat and air threat warning conditions.

a. Air defense conditions are stated in the OPORD:

- **Red** indicates the attack is imminent by hostile aircraft or missiles.
- **Yellow** indicates that an attack is probable by hostile aircraft or missiles.
- **White** indicates that an attack is not likely by hostile aircraft or missiles.

b. A local air defense warning (LADW) describes the air threat in the immediate area (Figure 9-6). LADWs are designed to alert a particular unit, several units, or an area of the battlefield of an impending air attack. ADA units use LADWs to alert Army units about the state of the air threat in terms of "right here and right now." They can be used in conjunction with air defense warnings (ADWs). The following are examples of LADWs:

- **Dynamite** indicates an attack is in progress.
- **Look-out** indicates an attack is possible.
- **Snowman** indicates an attack is not likely.

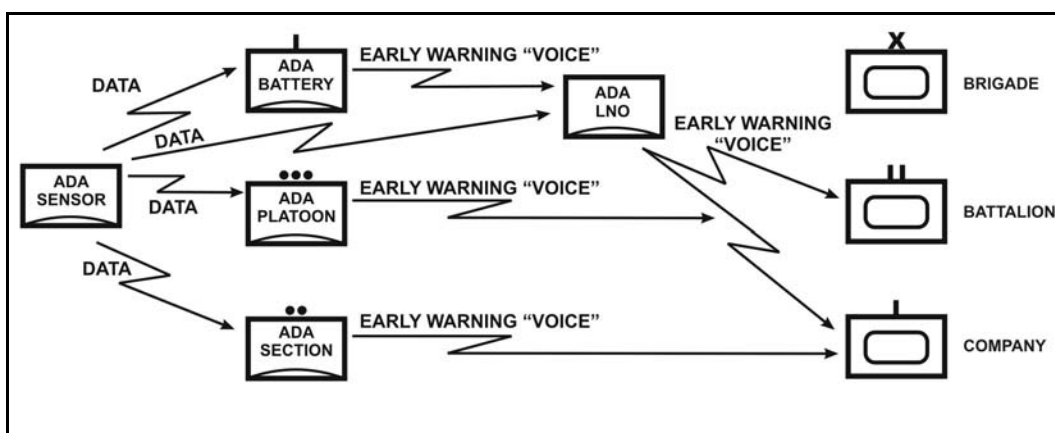


Figure 9-6. Air defense early warning.

c. Weapons control status determines the conditions for using weapons against enemy aircraft:

- **Weapons Free:** Soldiers may fire at any target not positively recognized as friendly.
- **Weapons Tight:** Soldiers may fire only at targets recognized as hostile.
- **Weapons Hold:** Soldiers do not fire except in self-defense or in response to a formal order.

## 9-50. AIR DEFENSE ASSETS

The following ADA assets support the TF as part of the attached ADA platoon.

a. **Bradley Stinger Fighting Vehicle.** The BSFV provides the air defender with armor protection and gives him the ability to maneuver with the supported force and position the Stinger system forward on the battlefield. The Stinger team must dismount to fire its missiles. The BSFV carries a basic load of six Stinger missiles as its primary air defense weapon. The BSFV's 25-mm chain gun can be used to augment the Stinger and cover dead space to a range of 2,000 meters. The vehicle also carries five TOW missiles.

b. **Bradley Linebacker.** The Bradley Linebacker replaces the BSFV's TOW system with four ready-to-fire Stinger missiles housed in the standard vehicle-mounted launcher (SVML). The Bradley Linebacker, with its ability to shoot on the move, eliminates the

need for the Stinger team to dismount from the vehicle, providing a significantly increased capability over the BSFV.

c. **Avenger.** The Avenger weapon system is a lightweight, day or night, limited adverse weather firing unit employed to counter low-altitude aerial threats. The FU consists of two turret-mounted SVMLs, a .50 caliber machine gun (M3P), a forward-looking infrared (FLIR) sight, a laser range finder (LRF), and an identification, friend or foe (IFF). The gyro-stabilized turret is mounted on the HMMWV. The FU can launch a missile or fire the machine gun on the move or from a stationary position with the gunner in the turret. It can also be remotely operated from a location up to 50 meters away. Onboard communications equipment provides for radio and intercom operations. The system is capable of climbing a 31-degree slope at 4 mph and traversing a 22-degree side slope from either side of the vehicle.

d. **Stinger Missile.** The Stinger missile is the task force's primary air defense weapon system. The Stinger is a short-range, heat-seeking guided missile that can be either shoulder-fired or fired from the SVML on the Bradley Linebacker. It is designed to counter the threat of advance helicopters, UAVs, remotely piloted vehicles (RPVs), high-speed maneuvering aircraft, and cruise missiles. The Stinger has a range in excess of 4 kilometers.

e. **Man-Portable System.** The Stinger can be employed as a man-portable air defense system (MANPADS). The two-man Stinger team, consisting of a gunner and a team chief, is transported in a HMMWV or BSFV.

---

## CHAPTER 10

# COMBAT SERVICE SUPPORT

*The modern battalion task force requires independent logistical systems and procedures and poses new challenges for CSS functions and leaders. With the development of new technological methods of sharing information such as FBCB2 and CSSCS, leaders at battalion task force and company team levels can provide the foresight and responsiveness necessary to anticipate and maintain the high operations tempo of TF operations.*

*The concepts and organizational structures found in this chapter reflect a paradigm shift from the supply-based CSS system of Army of Excellence to a technology-enhanced, distribution-based CSS system. A distribution-based logistics system combines information capabilities with efficient delivery systems to form an efficient distribution pipeline. Direct throughput of supplies from division and brigade to the battalion task force or company team is the rule rather than the exception with distribution-based logistics. The forward support company is the cornerstone of the distribution-based logistics system. The FSC is essentially all of the logistical elements that were in the AOE headquarters company maneuver battalion (except medical and communications repair) now organized as part of the forward support battalion. Personnel service support (PSS) functions, including manning and sustaining soldiers through religious, legal, and command information support, are the same as in the AOE structure.*

### Section I. COMBAT SERVICE SUPPORT FUNCTIONS AND ORGANIZATION

As much as possible, the burden of CSS is removed from the company team commander and placed under control of the task force. The company team commander concentrates on fighting his unit to accomplish the tactical mission. The CSS responsibility at company team level is primarily to report and request requirements and to ensure that CSS is properly executed once it arrives in the team's area.

#### 10-1. OVERVIEW

Regardless of whether the task force operates under the AOE or Force XXI CSS structure, the commander ensures that CSS is provided not only for his organic and attached elements but for any OPCON or supporting units as well. The task force provides mission-essential CSS to supported attachments. The S4 coordinates CSS for the attachments and verifies who is to provide this CSS and how it is to be requested. When a large attachment joins the task force, the attachment should bring an appropriate slice of CSS assets from its parent unit. These assets are controlled by the task force S4. The attached unit leader must coordinate with the task force S1 and furnish him with a copy of his unit battle roster. Thereafter, the attached unit submits reports and requests resupply according to the task force SOP.

a. In most tank and mechanized infantry battalion task forces, CSS assets are assigned to the task force HHC or the forward support company in Force XXI structured units. Under both CSS structures, the focal point for combat service support is the task force combat trains CP. The combat train CP anticipates, requests, coordinates, and supervises execution of combat service support either by HHC or FSC assets.

b. Key CSS functions include logistics support, personnel service support, and health services support.

(1) **Supply.** The supply function acquires, receives, and issues all classes of supply required by the task force.

(2) **Transportation.** The transportation function moves units, personnel, equipment, and supplies as required to support the concept of operations.

(3) **Maintenance.** The maintenance function keeps equipment and weapons in a serviceable, operational condition and conducts battle damage assessment and repair as necessary.

(4) **Field Services.** This function includes graves registration, clothing exchange, bath, salvage, laundry, textile renovation, airdrop and airlift, and bakery.

(5) **Personnel Service Support.** PSS includes a variety of functions that support a commander's ability to accomplish his mission and contributes to the welfare and morale of the soldier. Major CSS personnel service functions include –

- Personnel and administration services, which include strength and personnel accountability, replacement operations, casualty reporting, awards and decorations, and personnel management.
- Chaplain activities, which include conduct of services, personal and religious counseling, and pastoral care.
- Legal services.
- Finance services.
- Public affairs.
- Postal services.
- Enemy prisoner of war support.

(6) **Health Services Support.** This function includes treatment and evacuation, medical supply support, and preventive medicine.

c. The task force receives service support from various elements depending on the applicable CSS structure, either Army of Excellence or Force XXI.

(1) **Army of Excellence.** The XO, assisted by the command sergeant major, is responsible for coordinating all CSS in the task force.

(a) The S4 is responsible for the logistical support of the task force and for preparing paragraph 4 of the OPORD. He is assisted by the S4 section and the HHC support platoon.

(b) The S1 is responsible for personnel service support within the battalion and he coordinates the actions of the medical platoon. To assist him in this effort, he has a personnel and administration center (PAC).

(c) The battalion maintenance officer (BMO) is responsible for maintenance support and directs the activities of the maintenance platoon.

(d) The principal source of external support to the task force is the forward support battalion. It is organized with a headquarters and headquarters detachment, a supply company, a maintenance company, and a medical company to provide support to a



maneuver brigade. Additional support can be provided by the main support battalion of the division support command (DISCOM).

(2) **Force XXI CSS Redesign.** For the Force XXI task force, all CSS, minus medical, has been consolidated into the forward support company. The XO is still responsible for coordinating all CSS in the task force, and the S4 identifies the logistical requirements for the task force maneuver plan and provides the requirements to the FSC commander. The FSC provides all CSS (less medical) to the task force and is the CSS operator at the task force level. The principal source of external support to the task force is still the FSB; it is organized with a headquarters and distribution company (HDC), a base support company (BSC), a medical company, and three FSCs that provide DS centralized CSS support to each brigade maneuver task force. DISCOM still provides additional support from the MSB.

d. The increasing use of assured communications and improvements in information technology provide the CSS operator (either the HHC or FSC commander) and the S4 the information dominance and digital tools needed to tailor the CSS package. Through near real-time information, the task force battle staff is able to make timely adjustments in its support requirements. If equipped, CSSCS and FBCB2 are combat multipliers that provide logistics status and information in support of CSS planning and operations. CSSCS receives subordinate unit logistical reports from task force FBCB2 terminals, and it transmits reports and requirements to echelons-above-brigade support elements. The S1 and S4 link their FBCB2 terminal to the brigade CSSCS. They use this terminal to input data into the CSSCS network to conduct personnel transactions and to coordinate and receive supplies. Requesting of supplies and other logistical services is accomplished using standard Army management information systems (STAMIS) such as unit-level logistics system-general (ULLS-G), standard Army retail supply subsystem (SARSS), satellite automatic monitoring system (SAMS), supply property book system-revision (SPBS-R), and SIDPERS. The S1 and S4 use their FBCB2 logistics reports to provide input to both the brigade S1 and S4 and their supporting FSC.

## 10-2. COMBAT SERVICE SUPPORT RESPONSIBILITIES

The primary CSS functions required by the task force include casualty treatment and evacuation, resupply operations, maintenance activities, and personnel service support. The task force S1 and S4 sections collocate to form the rear CP in the combat trains. The following have the primary responsibility for CSS.

a. **S1 Section.** The S1 section is responsible for personnel services and the general administration of the task force. The S1 is assisted by the PAC supervisor and the personnel staff NCO. The S1 section has personnel at both the combat trains CP and the field trains (or TFSA under Force XXI). The S1 and his staff in the combat trains CP primarily perform the critical tasks of strength accountability and casualty reporting as well as command post functions. The S1 personnel in the field trains or TFSA perform replacement operations, administrative services, personnel actions, legal services, and finance services. The S1 also has primary staff responsibility for EPW operations and medical planning. He coordinates with the S2 for interrogation of prisoners and the S4 for processing captured equipment and transportation requirements. The S1 coordinates with the medical platoon leader to ensure that patient treatment and evacuation is planned and coordinated throughout the task force area.

b. **Medical Platoon.** The medical platoon sorts, treats, and evacuates casualties or returns them to duty. It stocks medical supplies for the task force and provides all Class VIII support. It is also responsible for maintaining and evacuating battalion medical equipment. The medical platoon's survivability and mobility are increased by the use of armored evacuation vehicles and aid stations. The medical platoon leader (a physician), with the aid of a physician's assistant, operates the battalion aid station. The medical operations officer, a medical service corps officer, coordinates the operations, administration, and logistics of the medical platoon. His duties include coordinating patient evacuation to the supporting medical company and providing support to company teams.

c. **S4 Section.** The role of the S4 differs somewhat, depending on the CSS structure that the task force operates under.

(1) Under AOE, the S4 section is responsible for all supply, transportation, and field service functions. It coordinates requisition and distribution of supplies to company supply sections and turns in captured supplies and equipment as directed. Personnel in the section are in the field trains and the combat trains CP. They are cross-trained with personnel of the S1 section in critical tasks to permit continuous operations. The S4 section is supervised by the S4 who is assisted by the battalion supply sergeant. Under Force XXI, the S4 focuses on planning CSS, identifying requirements, and coordinating for support through the FSC commander.

(2) In combat, under both AOE and Force XXI, the S4 concentrates on seven classes of supply: Classes I, II, III, IV, V, VII, and IX. The support platoon leader (or S&T platoon leader) coordinates the requisition, receipt, preparation, and delivery of Classes I, III, and V. This is done at the direction of either the FSC commander (Force XXI structure) or the HHC commander and S4 (AOE). The supply section coordinates the requisition, receipt, and delivery of Classes II, IV, VII, and IX.

(3) The S4 section and the support platoon (or S&T) are responsible for obtaining water and maps. Using transportation, water is obtained from the water supply point in or near the BSA or from forward sources tested and approved by the medical platoon leader. Maps are stocked by the supply and service company of the main support battalion, and they are requested through the forward support battalion. The S2 is responsible for distributing maps as required. Classified maps are obtained through G2 channels.

d. **Support Platoon/S&T Platoon.** Although AOE and Force XXI differ as to where the task force receives its transportation assets, the role of the support platoon (or S&T platoon) has the same primary function.

(1) **AOE Support Platoon.** The support platoon is comprised of a headquarters section, a transportation section (which includes a decontamination specialist), and mess sections. The transportation section is organized and equipped to transport fuel, ammunition, and supplies to the companies. The section normally transports a portion of the unit basic load of ammunition plus fuels and lubricants. The transportation section has a POL vehicle supervisor and, in armor battalions, an ammunition sergeant. It also has drivers assigned to operate the section's cargo vehicles. The mess section is organized and equipped to prepare meals for all elements of the task force. The support platoon also has the task force decontamination vehicle and operator to assist in unit decontamination. The support platoon leader works for the S4 and is under the supervision of the HHC

commander in the field trains. The platoon leader is assisted by the support platoon sergeant.

(2) ***Force XXI Supply and Transportation (S&T) Platoon.*** The S&T platoon provides supply and transportation support to the Force XXI task force in the same manner as the AOE support platoon. It is comprised of a platoon headquarters section, distribution section, and a food service section.

(a) ***Platoon Headquarters Section.*** The S&T platoon HQ section manages the distribution of supplies and food service coming from or passing through the FSC in support of the task force. The section utilizes ULLS-G/SAMS-1 and SARSS-1 interfaces to provide supply receipt and issue management for all classes of supplies except VIII (medical). This facilitates on-site item management. This section performs the following functions:

- Operates the ULLS-G/SAMS-1 and SARSS-1 systems.
- Maintains a current listing for all on-hand commodities.
- Processes receipts, issues, and turn-ins.
- Processes turn-ins to maintenance (for repairable items).
- Establishes facilities for limited storage, receipt, and issue of all supported commodities.
- Performs limited storage, receipt, and issue of all supported commodities.
- Delivers issued assets (LOGPAC) and pickup retrogrades (turn-ins to maintenance or for disposal).

(b) ***Food Service Section.*** The food service section provides Class I food service and food preparation (from the TFSA) for its own company and the TF. The food service section can prepare and deliver hot meals to the maneuver company team area. It distributes prepackaged food, prepared food, or both, from the TFSA. It can provide one "heat-and-serve" meal and one "cook-prepared" (A or B ration) meal per day.

(c) ***Distribution Section.*** The distribution section is responsible for supporting all classes of supply (except IX) coming from or passing through the FSC in support of a mechanized or armor battalion task force. This includes retail refuel operations from organic assets and ammunition resupply. The distribution section has the ability to conduct simultaneous Class III and V support to the company teams, HHC, and the FSC itself. The platoon is equipped with the following (the number of personnel and trucks varies slightly in each section based on the task organization of the TF):

- Ten HEMTT cargo trucks.
- Nine 2,500-gallon fuel truck tankers.
- Two fuel dispensing tankers.
- Eight 2-1/2-ton cargo trucks.
- Four light-medium tactical vehicle (LMTV) cargo trucks.

e. ***Maintenance Platoon.*** In both AOE and Force XXI, the maintenance platoon provides field maintenance to the task force. The platoon consists of a headquarters section, maintenance control section, recovery section, maintenance and service section, and the AOE company maintenance teams (CMT) or Force XXI combat repair teams. The maintenance platoon provides command and control and reinforcing maintenance to the CMT/CRTs. The CMT/CRTs provide field maintenance and battle damage assessment and repair to the company teams. As the commander task-organizes the force, all or part of a CRT goes with the company teams in order to maintain habitual support.

The platoon maintains a limited quantity of combat spares (prescribed load list [PLL] and shop stock) in the maintenance control section. The maintenance platoon operates the UMCP in the combat trains or field trains/TFSA area, depending on METT-TC. The maintenance platoon performs unit maintenance on all task force equipment except COMSEC and medical equipment. The platoon leader is normally the battalion maintenance officer. He is assisted by the maintenance technician and the battalion motor sergeant. When a company is detached from the battalion, the BMO detaches a supporting maintenance package that includes the personnel, tools, test equipment, and PLL stocks necessary to support the company.

(1) **Headquarters Section.** The maintenance platoon headquarters section provides command, control, and supervision for all administrative functions of the platoon. With guidance from the HHC/FSC commander, it plans and conducts all necessary training activities.

(2) **Maintenance Control Section.** The maintenance control section is the primary manager for all field maintenance in the task force. The maintenance control section performs all of the Army maintenance management system (TAMMS) and dispatching operations and tracks scheduled services for the task force using ULLS-G. All company team ULLS-G boxes and PLL clerks are collocated with the maintenance control section. The maintenance control supervisor manages the ULLS-G operators. The ULLS-G clerks operating each company team box process each DA Form 5988-E completed by the operator or crew and verified by the CMT/CRT.

(3) **Maintenance and Service Section.** The maintenance and service section provides habitual field maintenance for the FSC and maneuver TF HHC. This section also provides maintenance support to elements attached to the task force and provides reinforcing maintenance to the CMT/CRTs.

(4) **Recovery Section.** The recovery section provides recovery support to elements of the FSC (or task force HHC). This section also provides limited reinforcing recovery support to CMT/CRTs. The major equipment in this section consists of three wreckers (one 5-ton, one medium tactical vehicle, and one 8x8 heavy tactical vehicle) and six M88 recovery vehicles. When reinforcing recovery support is required, CMT/CRTs submit a support request to the maintenance control section.

(5) **Company Maintenance Teams/Combat Repair Teams.** The task force's first level of support comes from the FSC CRTs (under Force XXI) or from the HHC CMT (under AOE), which are organized to provide field maintenance (organizational and direct support maintenance levels) for all combat platforms organic to company teams. The CRT functions in the same manner as the CMT under AOE except that the organizational maintenance mission has been added to the CRTs' responsibility. The company team commander sets the CMT/CRT priorities. The CMT/CRT operates under the control of the maneuver company team 1SG and is supervised by the CMT/CRT maintenance NCOIC. CMT/CRTs carry limited onboard combat spares to help facilitate repairs forward. If inoperable equipment is not repairable, due either to METT-TC or a lack of repair parts, the team uses recovery assets to recover the equipment to the UMCP or designated linkup point. CMT/CRTs are fully integrated into the maneuver units' operational plans. Major equipment in the CMT/CRT includes--

- One M113 personnel carrier.
- One M88A2 recovery vehicle.

- One 5-ton cargo truck.
- One 2-1/2-ton cargo truck.
- One contact maintenance truck (Force XXI).
- One forward repair system (Force XXI).

f. **Support Operations Section (Force XXI Design).** This section coordinates and provides technical supervision for the FSC's CSS mission. This mission includes DS supply, field maintenance and recovery operations, and the coordination of transportation and field services. The support operations section (consisting of the support operations officer and four enlisted soldiers) collocates with the S1 and S4 sections at the CTCP. The FSC support operations section performs the following general tasks:

- Coordinates and provides technical CSS assistance to the task force S4.
- Advises the task force commander on requirements versus available assets.
- Determines CSS requirements in coordination with the FSB support operations section, task force S4, and the logistics representatives from attached units.
- Provides input to the task force logistics estimate and service support paragraph of the OPORD.
- Plans and monitors support operations and makes necessary adjustments to ensure support requirements are met.
- Tracks available assets through subordinate company teams, FSB support operations section, TF S4, and other units.
- Keeps the FSB support operations section abreast of the logistics situation and requests backup support when needed.
- Recommends support priorities and enforces priorities received from higher headquarters.
- Coordinates with the S4 and HHC commander on CTCP locations.
- Plans and executes contingency operations as required.
- Coordinates with the S3 and S4 on primary and alternate routes into the TFSA.
- Plans and coordinates allocation of available resources.
- Establishes and monitors brigade and task force logistics situation report (LOGSITREP), logistics status (LOGSTAT), and logistics (LOG) spot reports IAW SOP.
- Plans future logistics operations in coordination with the S4.
- Develops and maintains tactical and CSS overlays.
- Develops the CSS synchronization matrix.

### **10-3. THE HEADQUARTERS AND HEADQUARTERS COMPANY (AOE)**

Under the Army of Excellence, the battalion (BN)/TF HHC provides the BN/TF supply, maintenance, medical, and transportation support similar in scope to that of the forward support company. The HHC, augmented by the FSB maintenance, supply, and medical companies, provides field maintenance and all classes of supply, including medical, to its supported BN/TF.

a. The BN/TF HHC includes a support platoon and a maintenance platoon organized to provide direct support to the battalion. The BN/TF echelons support into combat and

field trains. TF combat trains are normally situated one to four kilometers behind the BN/TF while the BN/TF field trains are located within the brigade support area, 15 to 25 kilometers to the rear. The maneuver unit company supply sergeants are located in the field trains. They assemble their LOGPACS and then move their vehicles forward to the BN/TF logistics release point. The company first sergeant or his representative then meets the LOGPAC and guides it to the company resupply point.

b. The BN/TF locates the S1/S4 in the combat trains command post within the TF combat trains. These trains are normally comprised of a unit maintenance collection point, battalion aid station, and emergency classes of resupply (such as Class III and V) loaded onto support platoon assets. The TF combat trains are controlled by the S4, who is assisted by the S1 and battalion maintenance officer. Maintenance teams are sent forward to each company team under the supervision of their respective ISGs. The ISG also has under his control combat medical teams with track ambulance capability from the HHC. Casualties are evacuated by track ambulance to the casualty collection point, consolidated, and further evacuated back to an ambulance exchange point. Figure 10-1 shows a doctrinal template on how to deploy the HHC to support the BN/TF. Figure 10-2 depicts the HHC organization.

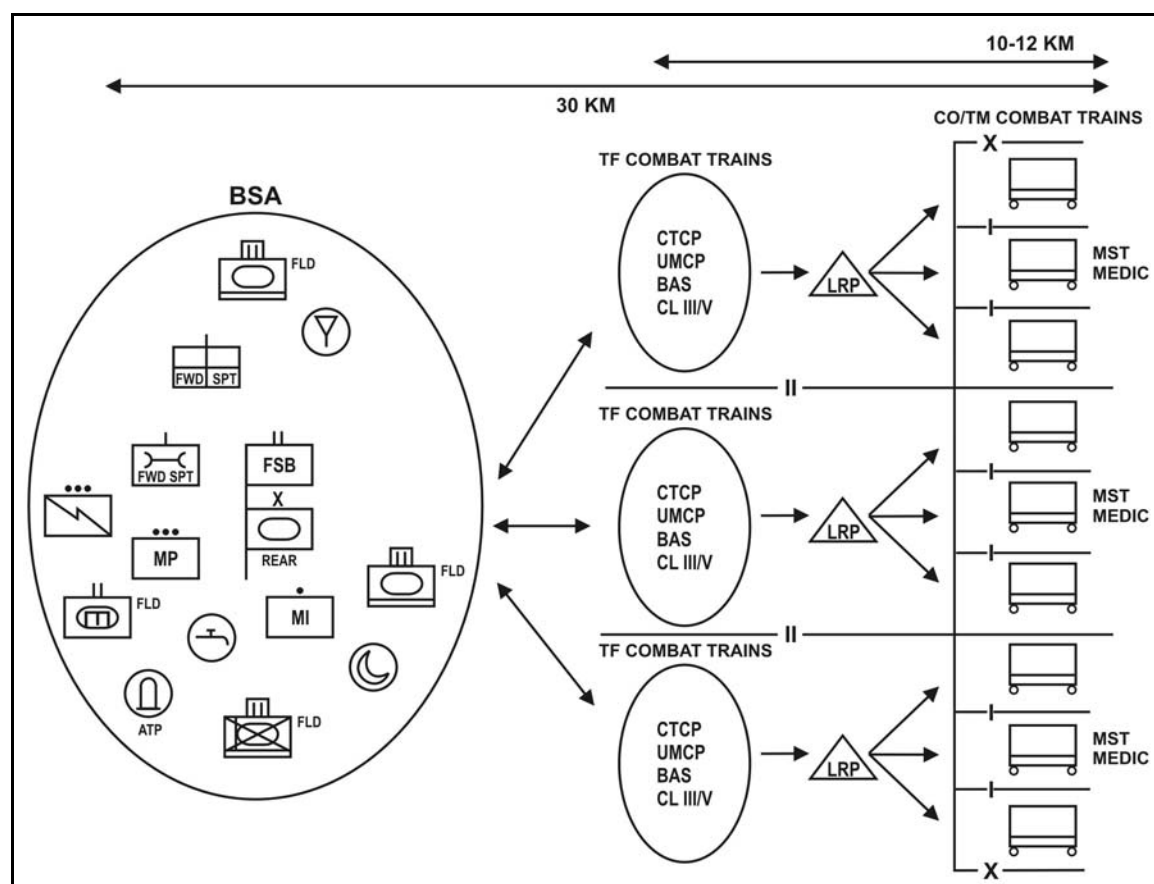
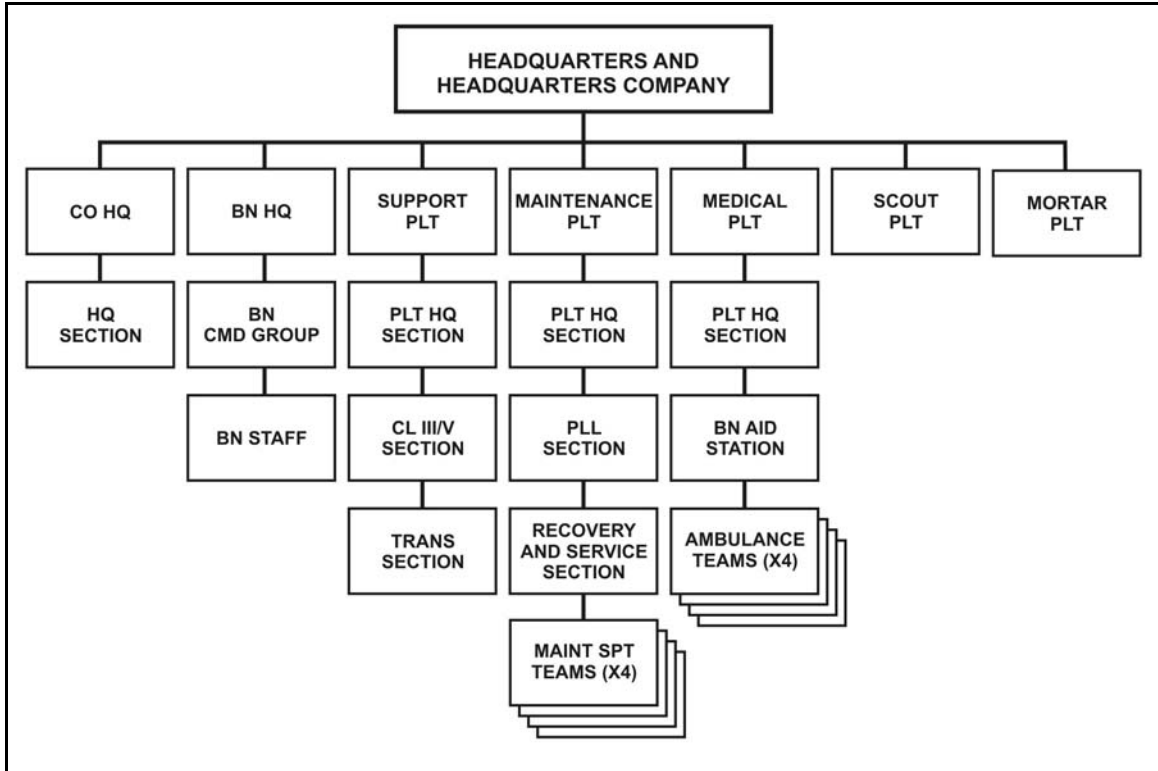


Figure 10-1. CSS operations brigade and below AOE.



**Figure 10-2. Headquarters and headquarters company.**

#### 10-4. THE FORCE XXI FORWARD SUPPORT COMPANY

Under Force XXI, the FSC commander is the CSS operator for the task force. The FSC is tasked and emplaced by the task force commander. The FSC provides field maintenance and all classes of supply, minus medical, to the task force while the task force provides Echelon 1 medical support to the supporting FSC. The FSCs accomplish their core functions through centralization of support. Centralization of support accomplishes the dual functions of providing the task force commander with greater mobility as well as increased efficiency and effectiveness in the flow of support and supplies. Centralized support allows the FSB commander to cross-level between FSCs and weight the battle logistically or surge, as required. Centralization of support is enhanced through employment of maturing technology available to the division logistician. The FSC has the capability to command, control, and integrate attached units such as engineer support teams or teams from corps. When equipped with FCB2, the FSC has the capability to provide near real-time information on the battlefield which greatly assists in the support effort.

a. The FSC is a multi-functional unit that includes an S&T platoon and a maintenance platoon organized to provide habitual and direct support to a maneuver battalion. Based on METT-TC, the FSCs locate 4 to 12 kilometers behind their supported task force in the task force support area. The maneuver unit company supply sergeants are located in the TFSA. They assemble their LOGPACS and then move their vehicles forward to the logistics release point. The company first sergeant or his representative meets the LOGPAC and guides it to the company resupply point.

b. The FSCs collocate their support operations cell with the task force CTCP in order to integrate the S4 and S1 with the FSC support operations officer (SPO). This CTCP is located within the TF's combat trains, one to four kilometers behind the BN or TF, and controlled by the task force HHC commander. Based on METT-TC, the HHC commander has the flexibility to locate the UMCP, recovery, emergency resupply of Class III and V, and other assets throughout the task force area of operation. The task force will also normally locate its aid station within the combat trains for force protection and proximity considerations. Combat repair teams from the FSCs are attached to each company team under the supervision of the company or team 1SG. The 1SG also has under his control the combat medical team with track ambulance capability from the HHC. Casualties are evacuated by track ambulance to the casualty collection point where they are consolidated and further evacuated back to an ambulance exchange point. Figure 10-3 shows a doctrinal template on how to deploy the FSC to support the task force. Figure 10-3 and Figure 10-4, page 10-12, show doctrinal templates on how to deploy the FSC to support the task force.

c. Both the FSB and the task force commander must ensure that the FSC is tightly integrated into the task force's operations in garrison, in training, and when deployed. In combat, the task force commander is responsible for the positioning, movement, and security of the FSC.

d. The FSB provides backup support to the FSC when requirements exceed its capabilities. The CSS structure's capability to project, receive, and support the task force directly affects the effectiveness of the task force and its ability to accomplish its mission.



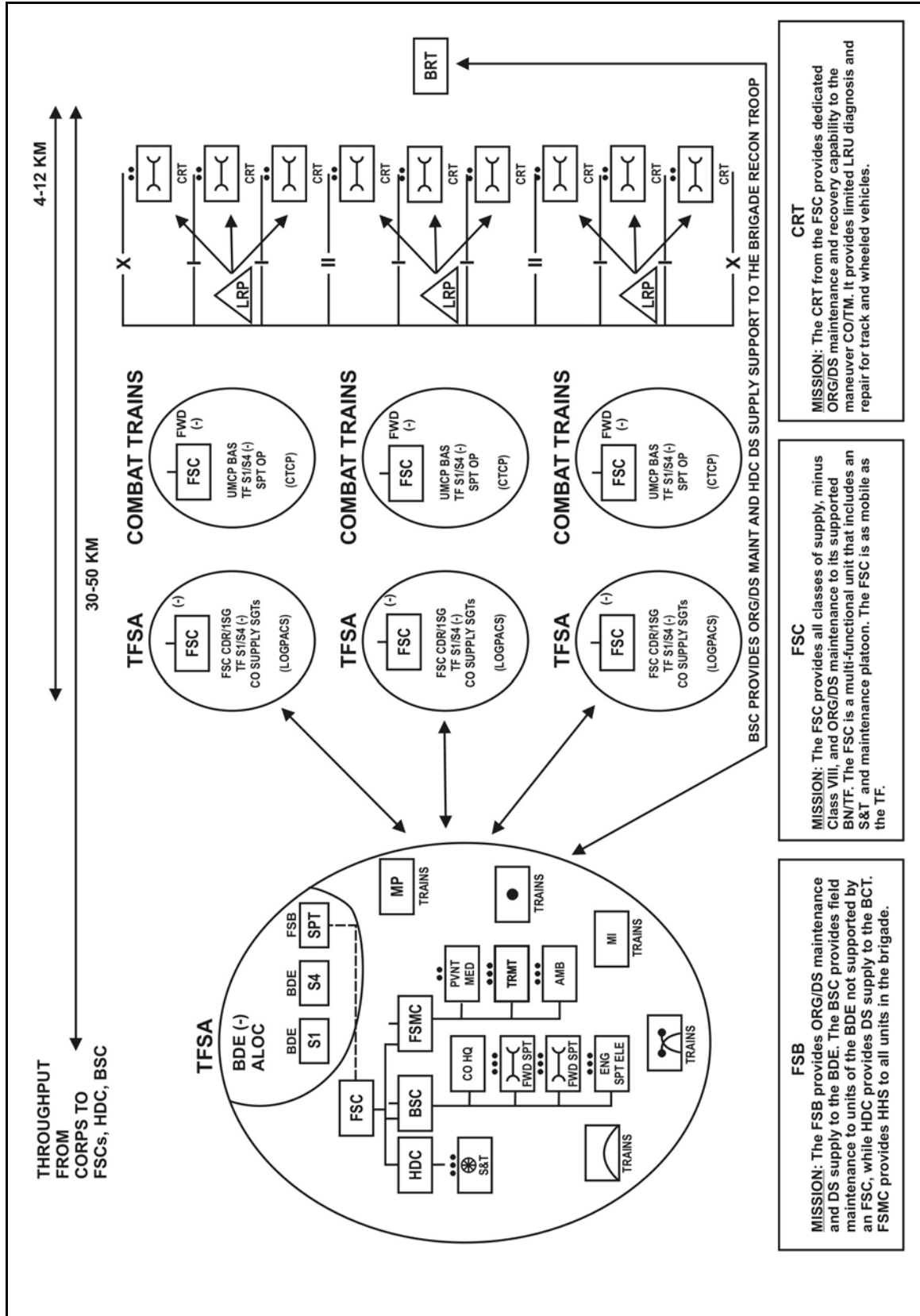


Figure 10-3. CSS operations brigade and below for Force XXI BCT.

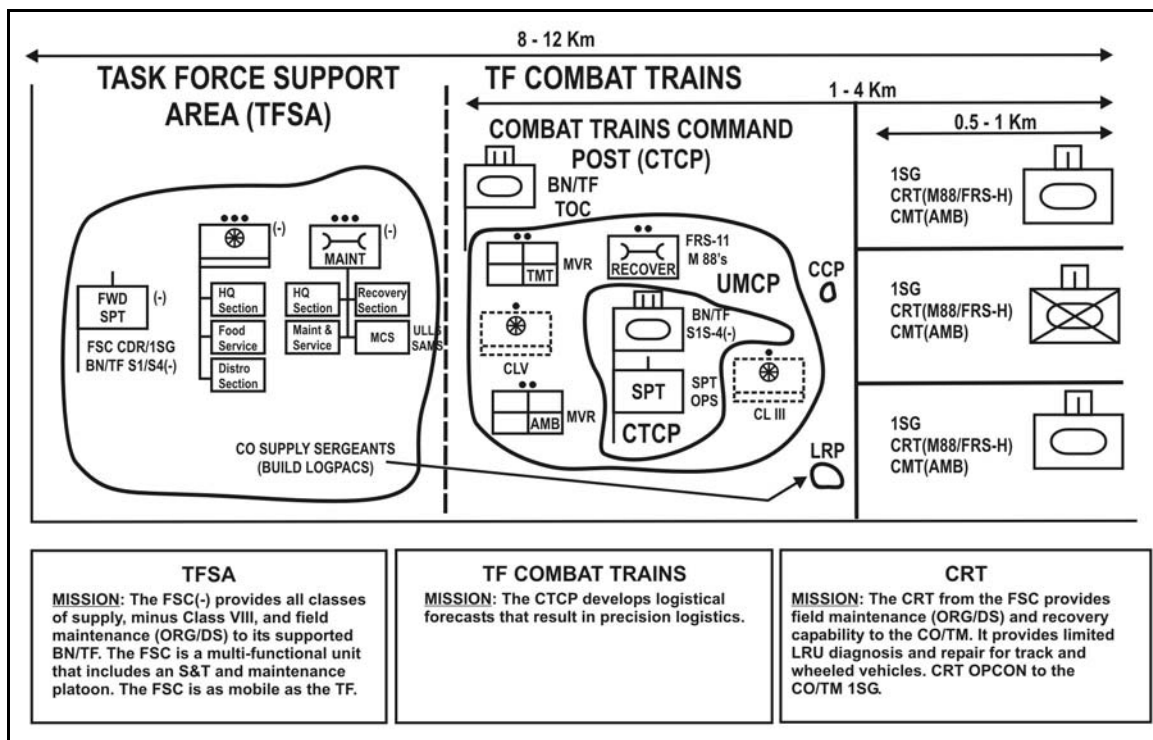


Figure 10-4. Forward support company doctrinal template.

### 10-5. FORWARD SUPPORT COMPANY ORGANIZATION

Under Force XXI, the FSC has replaced many of the HHC CSS functions for the task force as shown in Figure 10-5. The field trains command post has been replaced with the FSC CP headed by the FSC company commander. The FSC organization and functions differ from those of the former HHC organization and function.

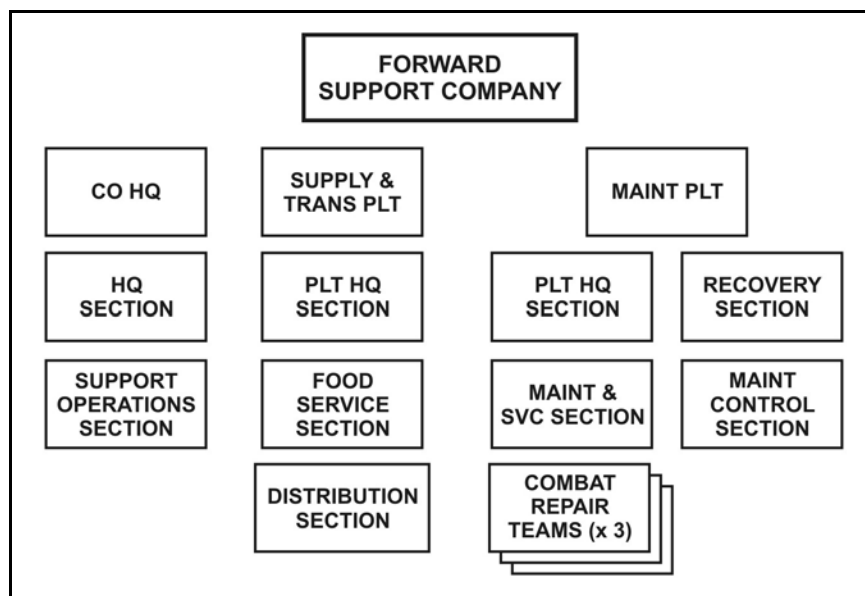


Figure 10-5. Forward support company.

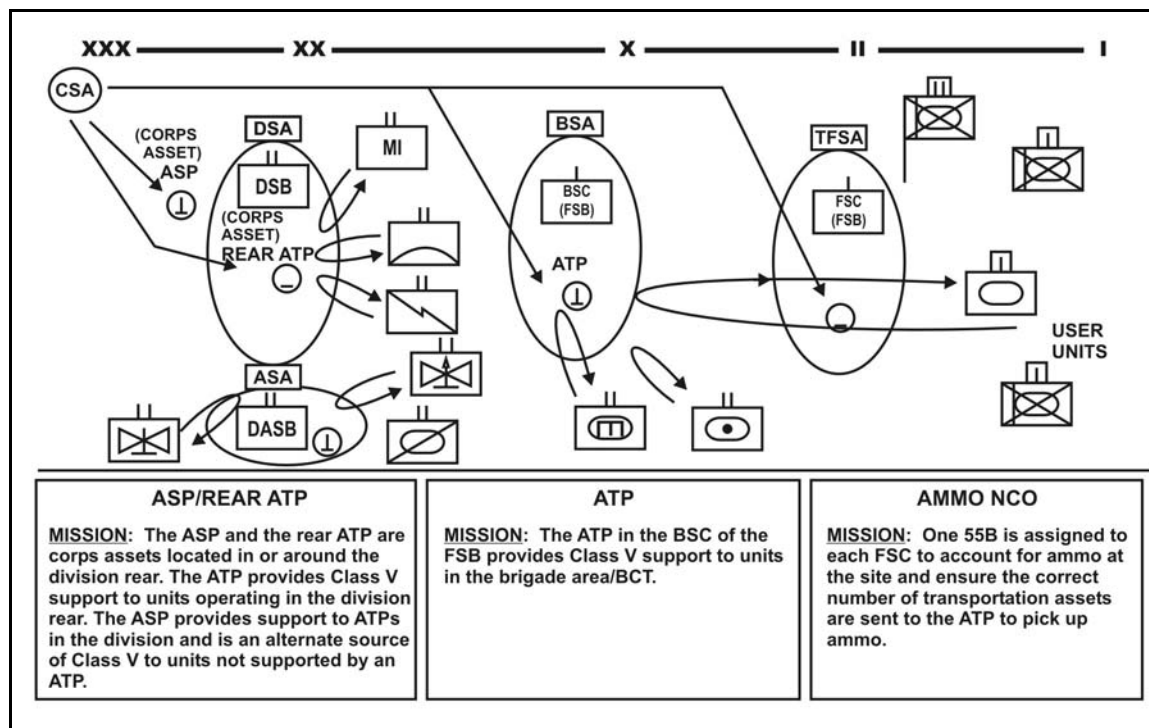
---

## **Section II. COMBAT SERVICE SUPPORT OPERATIONS**

At the tactical level, CSS elements provide centralized support that is coordinated and tailored for the warfighter. They control austere supply inventories and the maintenance, transportation, personnel, medical, finance, and field service capabilities necessary to satisfy specific tactical requirements. Increasingly efficient digital information systems enable the CSS manager and tactical leadership in the task force to anticipate, diagnose, and monitor the status, control, and flow of support assets that are required to support the immediate CSS situation. This information is essential during deployment as the organization arrives in its assigned area of operation. (See Appendix H, Deployment.) Even with these advanced capabilities, the combat service support system is challenged to sustain the task force in full-spectrum operations. This section addresses the six essential support (sustainment) functions of arm, fuel, fix, move, sustain, and man.

### **10-6. ARM (CLASS V)**

Units report on-hand ammunition status to the 1SG, with an information copy going to the company team commander. The 1SG consolidates the unit's on-hand quantities and forwards them to the S4 using FM, hardcopy turned in at the LRP, or using rollup procedures in the LOGSTAT in FBCB2, with information copies to the FSC and support operations officer. Company team commanders indicate in their LOGSITREP any critical ammunition shortages or forecasted changes in ammunition requirements. By continuously analyzing the task force ammunition status, the S4 can recommend cross-leveling between company teams or request for additional Class V from the TFSA or field trains. The FTCP or TFSA CP determines whether or not the request can be filled at its level. If so, it tasks the support/S&T platoon to supply and deliver the Class V. If the FTCP or FSC cannot fill the request, it forwards the request to the FSB SPO located at the BSA. (Refer to Figure 10-6, page 10-14, for an example of Class V distribution to the task force.)



**Figure 10-6. Class V resupply (Force XXI).**

a. The S4 determines when there is a change in mission or continuous support ammunition resupply requirements based on information provided in the situation report (SITREP), LOGSTAT, and guidance received from the task force commander and S3.

b. The S4 ascertains whether the request is normal resupply or an emergency requirement. Submission of daily LOGSTATs in accordance with unit SOPs addresses normal resupply, although the S4 may submit a request to the brigade administrative/logistical operations center (ALOC)/FSB support operations.

c. The S4 submits company team rollups for ammunition resupply to the brigade S4 through the LOGSTAT report. The brigade S4 consolidates the ammunition requests and passes the consolidated request to the support operations officer located in the supporting FSB. The support operations officer then requests the ammunition support from the division ammunition officer (DAO) located in the Class V section of the division support operations section.

**10-7. FUEL (CLASS III, BULK)**

In Force XXI, the base support company S&T platoon of the FSB is responsible for receipt, storage, issue, quality control, delivery, and dispensing of Class III (B). It provides direct support resupply to the FSCs and area support to brigade units. The section also provides retail service in the BSA. It provides supply point distribution to units in the BSA. The section can provide a normal half-day supply to the FSCs. Under AOE, the FSB supply company provides the same Class III service to the task force HHC support platoon.

- a. The distribution section of the support/S&T platoon is responsible for distribution of Class III (B) to the task force. The HHC/FSC's HEMTTs conduct resupply fuel operations for the company teams.
- b. Fuel status is initiated at the platoon or company team level and reported to the 1SG. Information copies are furnished to commanders at each echelon. The 1SG consolidates on-hand quantities and submits the fuel status to the S4, with an information copy to the FSC support operations section. In the absence of reports, the S1, S4, and HHC/FSC should anticipate unit requirements when assembling LOGPACs.
- c. The S4s submit their forecasts and status reports to the brigade S4 and the FTCP or FSC support operations section which in turn passes the request along to the FSB SPO. The FSB support operations section submits the consolidated forecast and requirements to the DISCOM support operations section.
- d. For emergency resupply, the units request fuel via FM voice followed up with an FBCB2 call for support (CFS) (if equipped). If the FSC cannot fill the request, it forwards the request to the FSB support operations section with a copy to the brigade S1/S4. (Refer to Figure 10-7 for an example of Class III [B] distribution to the task force.)

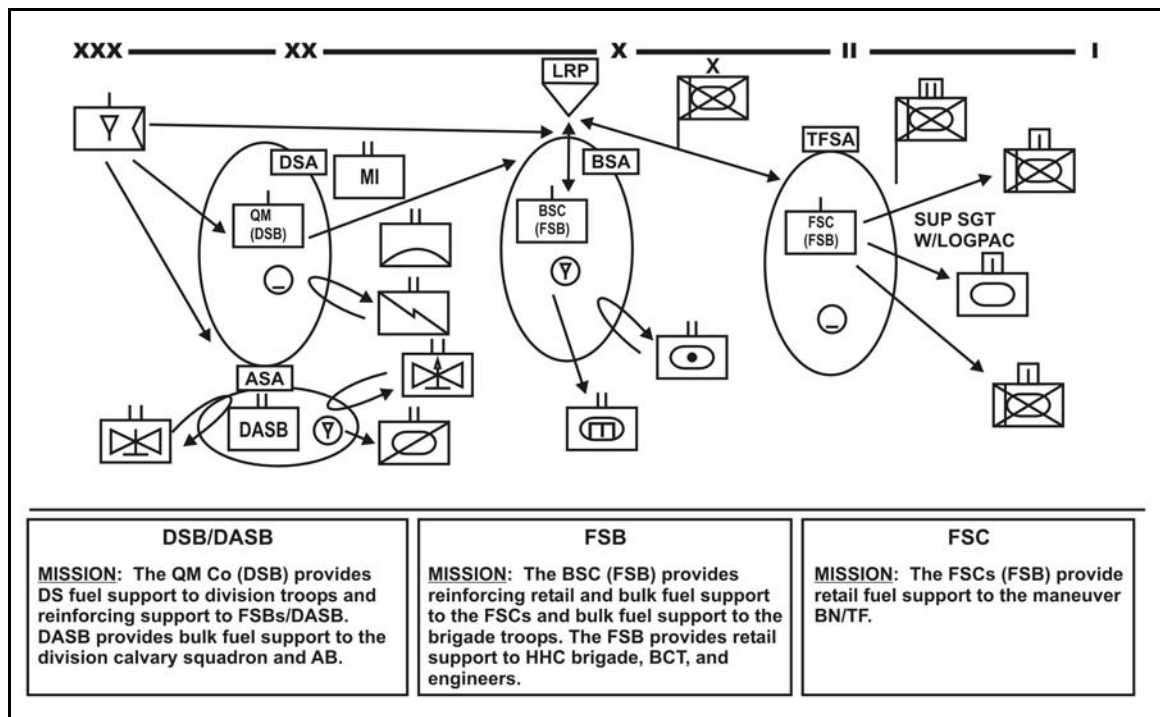
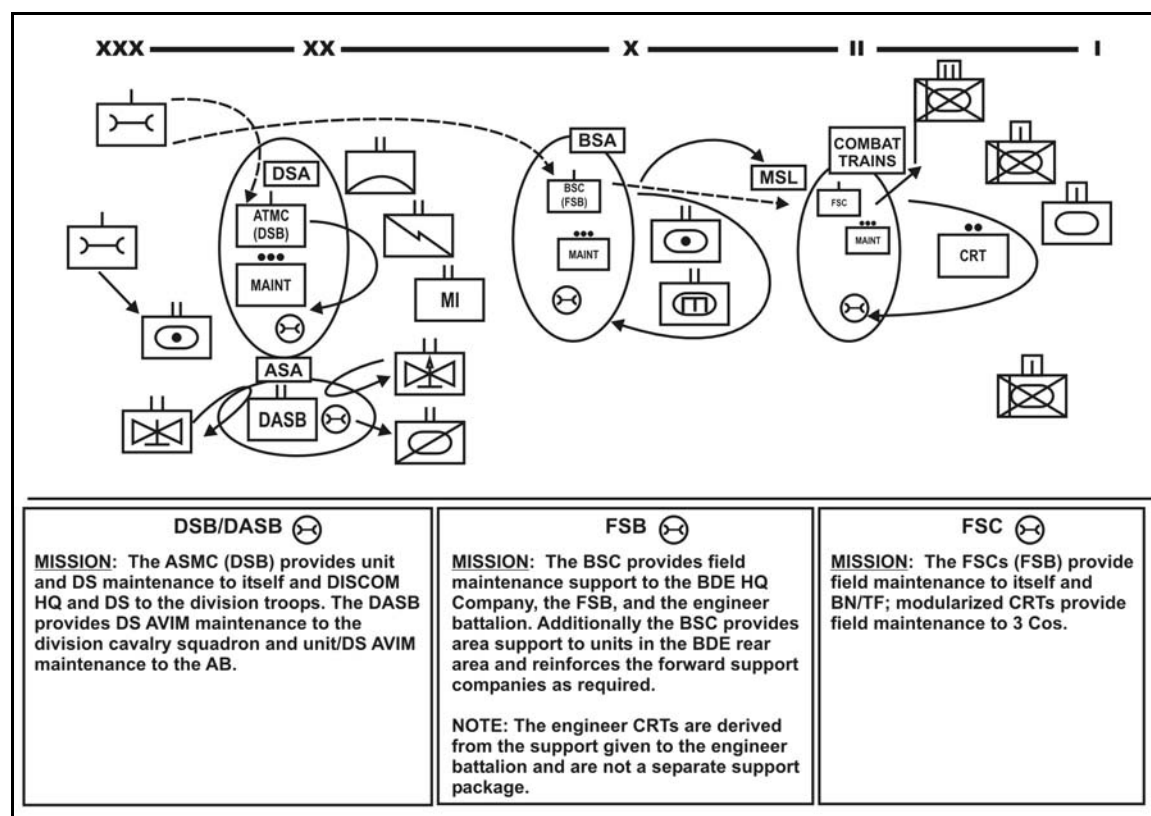


Figure 10-7. Class III (B) resupply (Force XXI).

**10-8. FIX**

The overarching principle of performing maintenance as far forward as possible on the battlefield remains unchanged in task force operations. Mechanics accomplish their mission by using advanced diagnostics and prognostics to diagnose the major component fault and then replace the component under the replace-forward concept. "Replace forward" focuses on "on-system" maintenance tasks or those tasks that can be performed at the breakdown site (if possible) or at the UMCP. An operator performs preventive

maintenance checks and service (PMCS), and the fault(s) are transmitted using electronic technical manual-interface (ETM-I). Depending on the urgency of the fault, the operator may notify the CMT/CRT via FM or FBCB2 (if equipped). The CMT/CRT diagnoses the fault and identifies the Class IX required. If the part is on hand, the CMT/CRT repairs the fault. If the part is not on hand, a request is passed to the maintenance control section. The maintenance control section determines whether the part is on hand in the supporting PLLs. If on-hand, it is released; if not, the maintenance control section requests the part via ULLS-G or SAMS. These requests are forwarded to the SARSS-1 located in the HHC/FSC's supply section. Since the SARSS-1 site does not maintain stockage of Class IX, the request is forwarded to the SARSS-1 in the AOE maintenance company or Force XXI BSC. (Refer to Figure 10-8 for typical maintenance communication flow within the division.)



**Figure 10-8. Maintenance communication flow (Force XXI).**

a. **Company Maintenance Teams/Combat Repair Teams.** The CMT/CRTs are the first level of support for the task forces. If the time, tools, test equipment, and parts are available, the team repairs the equipment, returning it to mission-capable status. Most of their support during combat, however, consists of BDAR, diagnostics, and on-system maintenance through the replacement of line replacement unit (LRU) components. The CMT/CRTs operate in the company team's combat trains and directly support the company team. The CMT/CRT NCOIC, who coordinates all support requirements with the company team, controls the movement of the CMT/CRTs as directed by the company team 1SG or XO. The CMT/CRTs respond to the company team's voice or FBCB2 (if

equipped) requests for support. They also provide recovery support for the company team. They evacuate jobs according to a set timeline (Figure 10-9). The CMT/CRTs do not carry large quantities of Class IX but do carry limited combat spares and selected LRUs (tailored to their supported unit) to facilitate repairs forward. When the workload exceeds the CMT/CRTs' capabilities, they request reinforcement through the maintenance platoon's maintenance control section located in the UMCP or TFSA. The maintenance platoon provides limited Class IX support and can provide additional repair and recovery support.

<b>TIME FOR REPAIR (HOURS)</b>	<b>LOCATION</b>
<b>LESS THAN 2</b>	<b>ON SITE</b>
<b>2 TO 6 (AND CAN BE TOWED UNTIL REPAIRED)</b>	<b>UMCP</b>
<b>6 TO 25 (OR LESS THAN 6, IF VEHICLE CANNOT BE TOWED)</b>	<b>FIELD TRAINS/FSB MAINTENANCE COMPANY (BSA)</b>
<b>24 TO 36</b>	<b>DSA</b>

**Figure 10-9. Maintenance time guidelines.**

b. **Maintenance Platoon.** The maintenance platoon (-) positions behind the CRTs in the UMCP. This platoon provides C2 and backup maintenance to the company team CRTs. The platoon (-) locates in the combat trains and establishes the task force UMCP. Backup maintenance support is provided to the FSC by the BSC or AOE maintenance company. Additionally, the FSB can provide a combat authorized stockage list (ASL) that includes major assemblies, key tank, and BFV LRU components.

**10-9. MOVE**

Dependent on AOE or Force XXI structure, either the FSC support operations section or CTCP assumes the movement, materiel management, and maintenance evacuation functions for the task force. The S4 coordinates with either the FTCP or the TFSA CP in order to synchronize the delivery of all classes of supply with units. Requirements not within the FTCP's or the TFSA's capabilities are transferred to the FSB support operations. The task force CTCP schedules and synchronizes transportation support. The FTCP or TFSA CP coordinates inbound and outbound shipments with the FSB movement control NCO.

a. When equipped, FBCB2 allows for the connectivity and visibility of assets and support for current and future operations. Additionally, the movements tracking system (MTS) provides near real-time visibility of the GPS location of the transportation resources throughout the brigade support area.

b. The S3 plans, coordinates, and controls tactical movement for the task force. The S3 plans unit movements, and the S4 normally coordinates them. The S4 is the logistical movement manager.

c. The support/S&T platoon provides the primary source of transportation and executes transportation missions for the task force. The S4 consolidates support requirements and passes them to the FTCP or TFSA support operations section for execution. The S4 also maximizes the use of returning vehicles by coordinating with company teams to return recoverable parts to the BSA/TFSA.

d. When units require additional transportation support, they submit a request to the S4. The S4 coordinates with either the FSC support operations section or coordinates with the FSB support operations section for additional assets if required. Information is also provided to the brigade S4 so that they have overall knowledge of activity within their respective area.

#### **10-10. SUSTAIN**

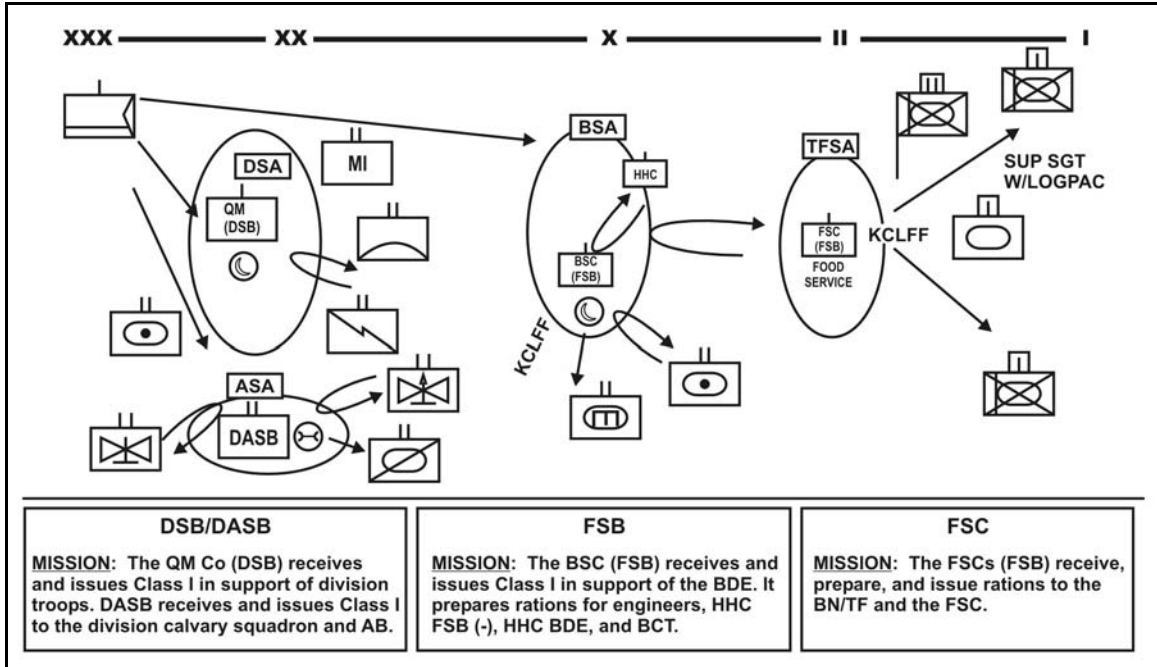
Sustainment functions include Classes I, II, III, IV, VI, VII, VIII, and IX, plus field, religious, postal, finance, and legal services.

a. **Class I.** The food service section (from the FSC or HHC) provides consolidated food preparation for the task force. The HHC/FSC has the ability to prepare meals forward in each company team area based on METT-TC. The food service section cooks unitize group ration A (UGR-A) or B (UGR-B), or heats the heat-and-serve meal in its organic mobile kitchen trailer (MKT). Food can be packed in insulated food containers and sent with the LOGPAC to company team locations where company team soldiers serve the meals.

(1) The supported force's head count determines the quantity of rations requested. Platoons transmit headcounts for rations through the company team to the task force. The S4 consolidates all subordinate unit head counts and transmits the total projected head count to the brigade S4 and or HHC/FSC support operations section. (Refer to Figure 10-10 for an example of the typical Class I distribution system within the division.)

(2) When the unit is engaged in combat, the ration-supplement health care package (HCP) is usually issued with the rations. These supplement HCPs should not be confused with Class VI supplies, which include toilet articles and confections.

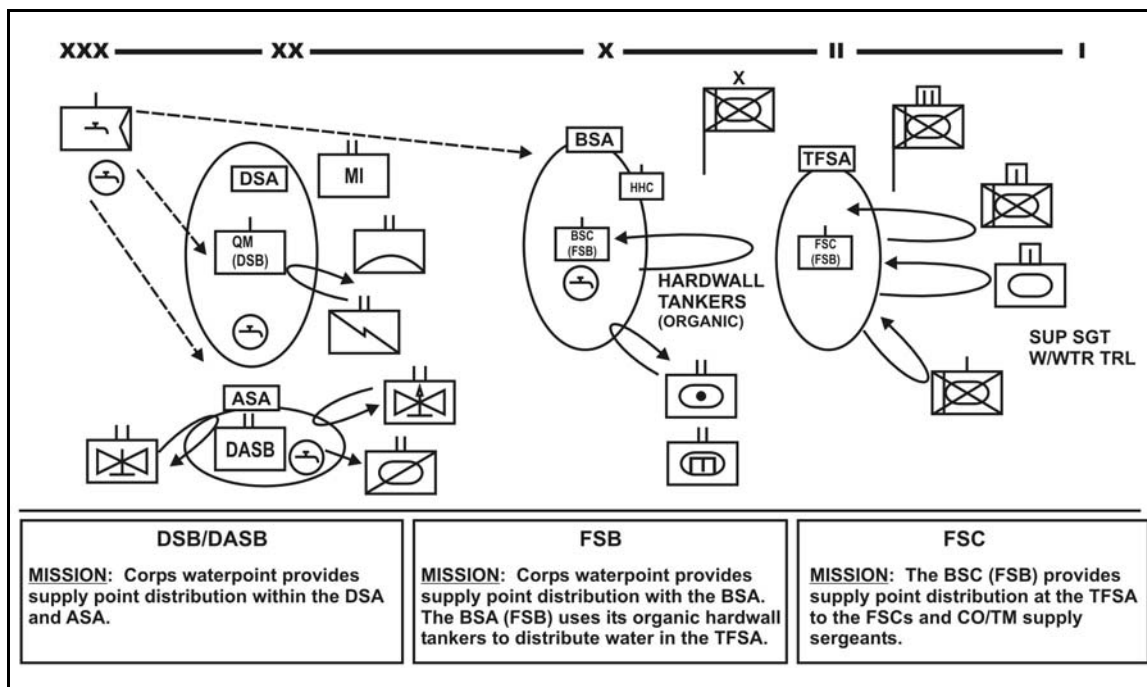




**Figure 10-10. Class I distribution (Force XXI).**

(3) There is no organic water purification capability within the division. Corps water purification units can augment the FSB to provide water purification and storage. Within the brigade, the FSB can distribute water forward to the HHC/FSCs in the form of hard-wall tankers. Maneuver company team supply sergeants are required to fill their water trailers at the BSA/TFSA. In the division support area (DSA), the quartermaster company has the ability to store limited quantities of water in bags mounted on trailers or in hard-wall tankers.

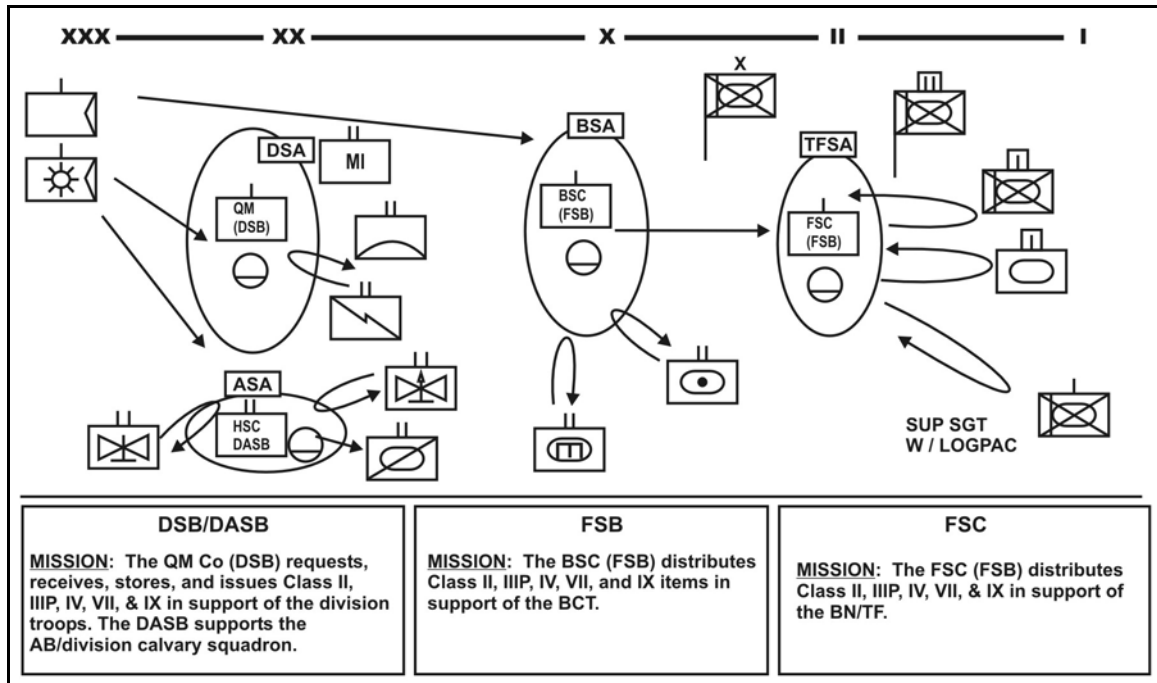
(4) The primary method of water distribution is via supply point in the quartermaster company. (Refer to Figure 10-11, page 10-20, for typical water distribution operations within the division.) In an arid environment, an arid environment water team augments the division support battalion (DSB) and FSBs in order to increase water storage capabilities for water storage and distribution.



**Figure 10-11. Water distribution (Force XXI).**

(5) Bottled water may be locally procured or shipped from outside the theater of operations. Bottled or packaged water is particularly well suited for reception, staging, onward movement, and integration (RSOI) and initial operations but may be routinely issued throughout an operation or conflict depending on the situation. It is normally requisitioned and distributed along with Class I.

b. **Classes II, III(P), and IV.** Classes II, III(P), IV, and unclassified maps include a wide variety of supplies and equipment from clothing and tools to packaged petroleum products and barrier materials. Units continue to request supplies and materiel through the appropriate STAMIS (ULLS-S4 to SARSS-1 or global combat support system-Army [GCSS-A]). (Refer to Figure 10-12 for an example of the typical flow of Class II, III [P] and IV within the division.) The support/S&T platoon maintains limited stockage supporting the task force. Company team ISGs consolidate requests and pass the requirements to the supply sergeant at the field trains or TFSA. The supply sergeant submits these requests via ULLS-S4. Unclassified maps and Class IV barrier materials follow the same requisition flow as Classes II, III (P), and IV supplies. These unclassified maps and barrier materials are stored in the receipt, storage, and issue section. Maps are issued through supply point distribution to supported units according to established tables of allowances or to fill special requirements. Classified maps are handled through S2 channels. Class IV countermobility materials are throughput to either an engineer pick-up point or site of emplacement.



**Figure 10-12. Class II, III (P), and IV operations (Force XXI).**

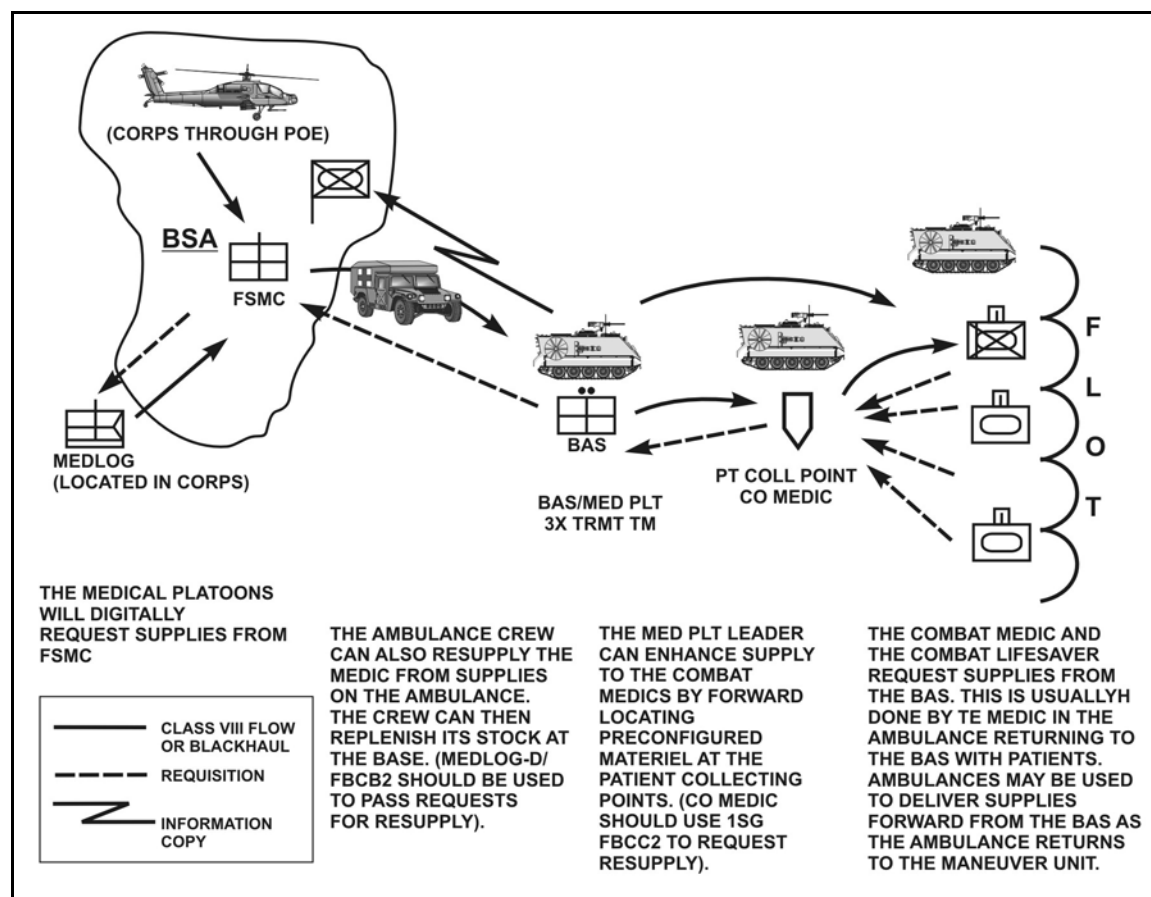
c. **Class VI.** Class VI supplies are those items used for personal hygiene, comfort, and welfare. They include such things as candy, gum, dental care products, soap, and stationery. Initially, the soldiers carry these personal items with them. As the supply system adjusts to demand, resupply is by ration-supplement HCP where personal demand items are issued gratuitously. Issue of Class VI items at battalion task force level follows SOP, normally through S4 channels, or coincides with the delivery of the Class I LOGPAC. When the situation permits, tactical field exchanges provide services to specified units or troop concentrations.

d. **Class VII.** Class VII items are intensively managed and are normally command-controlled. Class VII replacements are based on combat losses reported through command or S3 channels. This permits the commanders at all levels to remain apprised of the operational status of subordinate equipment. It also ensures distribution of items to those units having the most critical need. Weapons systems such as tanks are intensively managed by weapons system replacement operations (WSRO). If the item is a WSRO weapon system, the primary linkup points of the item with its crew may occur in the BSA or in designated assembly areas. Class VII requests are filled as combat loss reports are passed from company team level to the S4. The S4 consolidates the company team rollups and submits them to the brigade S4.

e. **Class VIII.** Class VIII items can be requisitioned as routine resupply or as immediate resupply.

(1) **Routine Requisitions.** The task force forwards its requirements for Class VIII resupply to the supporting medical company of the FSB. The medical company forwards an information copy of all requisitions within the task force directly to the supporting medical logistics (MEDLOG) company. An information copy also goes to the DISCOM medical material management branch (MMMB) and to the brigade surgeon's section (Figure 10-13, page 10-22).

(2) **Immediate Requisitions.** The task force submits its MEDLOG requests to the supporting medical company. The DISCOM MMMB attempts cross leveling within the medical companies in the division if it is the most expedient method of obtaining and shipping the required items to the requesting unit or element. If the DISCOM MMMB is unable to locate requested item(s) in the division, it forwards the request to the supporting MEDLOG company. The MEDLOG company forwards all immediate requests not filled to the MEDLOG task force's logistics support company located in the corps rear. The DISCOM MMMB monitors all immediate requisitions not filled by the MEDLOG company. The DISCOM MMMB expedites handling of these requests to ensure timely delivery and tracking of the critical Class VIII items.



**Figure 10-13. Class VIII resupply operations at echelon I.**

(3) **Delivery of Class VIII.** EAD transportation elements throughput Class VIII to the medical company in the BSA. The medical company configures Class VIII supplies in LOGPACs and transports them to the requesting medical units. Shipment of these Class VIII LOGPACs from the MEDLOG company is coordinated with the S4 and FTCP/TFSA CP.

f. **Class IX.** As a result of the implementation of field maintenance (combined organizational- and DS-level maintenance) under Force XXI, the maintenance control section of the FSC is now responsible for combat spares to include maintaining

prescribed load lists and shop supply items. Both of these inventories have very different requirements for adding and maintaining parts on inventory.

(1) The maintenance control section manages the PLL using the ULLS-G; it manages the shop stock using the SAMS-1. With the fielding of GCSS-Army, the maintenance modules will consolidate ULLS-G and SAMS-1 functionality. This combination will give the PLL clerks the ability to manage all combat spares for the task force. Combat spares consist of a broad but shallow inventory of high-use, combat-essential parts that support the replace-forward maintenance system.

(2) As mentioned earlier, the maintenance platoon (-) positions behind the CMT/CRTs in the UMCP or TFSA. This platoon provides C2 and backup maintenance to the CMT/CRTs. The platoon (-) also establishes the UMCP.

(3) The platoon provides all TAMMS and scheduled services for the task force. The platoon focuses on the forward maintenance effort in order to maintain maximum combat power. The task force XO determines the maintenance platoon's priorities.

(4) The maintenance control section receives, stores, and issues combat spares for the company team.

g. **Field Services.** Field services include mortuary affairs, airdrop, and laundry and shower activities.

(1) **Mortuary Affairs.** Unit responsibilities include initial recovery, search, and identification of deceased personnel. The unit evacuates deceased personnel to the nearest mortuary affairs support collection point. The unit transmits initial findings of its search-and-recovery teams to the mortuary affairs team.

(a) The FSB's support operations section coordinates the transportation of remains within the BSA. All personal effects found on the remains accompany the deceased when evacuated.

(b) The recommended method of evacuation of remains is air evacuation in coordination with the task force S3 air.

(c) The maneuver unit transmits evacuation requests to the S4. The S4 then coordinates with the support platoon or TFSA CP for evacuation.

(d) If evacuation requirements exceed the support/S&T platoon's capabilities, the FSB support operations section coordinates for additional lift.

(2) **Airdrop.** The unit sends requests for airdrop of supplies or equipment to the S4, which forwards it to the brigade S4 and FSB support operations section. The brigade S4 and FSB support operations section coordinate to make the appropriate coordination with the division G3, G4, and DISCOM support operations section.

(3) **Laundry and Shower.** The unit sends requests for laundry and showers to the S4, which forwards it to the brigade S4 and FSB support operations section. The brigade S4 and FSB support operations section make the appropriate coordination with DISCOM support operations section and the G4.

h. **Religious Support.** The task force chaplain is the staff officer responsible for implementing the religious program. This program includes--

- Worship opportunities.
- Administration of sacraments.
- Rites and ordinances.
- Pastoral care and counseling.
- Development and management of the unit ministry team.

- Advice to the commander and staff on matters of morals.
- Advice to the commander and staff on matters of morale as affected by religion.
- Ministry to casualties to include support of combat shock casualty treatment.

The chaplain's assistant is trained to assist the chaplain in religious support and is essential to the religious support mission. The assistant advises the chaplain on matters of soldier morale and serves as liaison with enlisted soldiers. The chaplain's assistant also advises the commander in the absence of the chaplain. All elements enhance the total well being of the soldier and increase the cohesion of the task force.

i. **Postal Services.** Mail is the soldier's link to family and friends. Inefficient distribution of mail can quickly undermine morale. In the early stages of a conflict, postal services to individuals are usually restricted to personal mail that conforms to the free mailing privilege. The brigade S1 establishes a daily mail schedule. Outgoing mail is consolidated at the FTCP/TFSA S1 section prior to being forwarded to the brigade S1. S1 personnel drop outgoing and pick up incoming mail at the brigade S1 section. E-mail service should be made available to soldiers but OPSEC considerations must be addressed.

j. **Finance Services.** The mission of finance support organizations during conflict is to provide high-priority support to the soldier on an area basis. This means the same finance unit supports all soldiers within a geographical locale, regardless of unit affiliation. During deployments, mobile pay teams from corps-level finance organizations provide support to the brigade. Individual soldiers are given the choice of receiving a specified amount of combat pay or cashing personal checks or other negotiable instruments for the same specified amount or less. The S1 coordinates with the brigade S1 for the support of the mobile pay teams.

k. **Legal Services.** The division staff judge advocate provides and supervises legal support to the brigade. Detailed brigade judge advocates provide or coordinate all legal support to the brigade. Legal NCOs and specialists in the task forces provide paralegal support for the task force. The US Army Trial Judiciary and US Army Trial Defense Service are independent organizations that provide military judge and trial defense services to the brigade.

## 10-11. MAN

Manning the task force is the process of getting the right soldier to the right place at the right time and with the right capabilities. The connectivity between smart cards, CSSCS personnel module, tactical personnel system (TPS), the integrated total Army personnel database (ITAPDB), and FBCB2 enables the S1 to account for personnel through all operational phases. This capability provides the commander with near real-time personnel information and accurate personnel accounting and is the foundation for successful casualty operations and replacement operations.

a. **Critical Manning Tasks.** Critical manning tasks are predicting, resourcing, monitoring, assessing, and adjusting. These tasks are iterative and do not follow a prescribed order or sequence.

(1) **Predicting.** The S1 must complete a loss estimate based on enemy and friendly force capabilities. This estimate provides planning parameters for replacements, medical facility and support requirements, and graves registration and mortuary affairs assets.

Automation allows the personnel planner to anticipate casualties using the digitized capabilities of the Army casualty information processing system (ACIPS) and FBCB2 (if equipped) to anticipate casualties.

(2) **Resourcing.** S1 planners fill units to their authorized strength according to the commander's priorities. This is the commander's "troops available" part of the METT-TC formula and is an essential part of the commander's combat power visibility. "troops available" includes soldiers, contractors, civilians, and personnel from other services and forces. The S1 then recommends available resource allocation of available resources to meet current and future requirements.

(3) **Monitoring.** The task of strength monitoring begins with establishing the unit-strength baseline. The S1, under the brigade S1's direction, manifests all deploying personnel. He transmits this information to the brigade- and division-level personnel operators performing manning tasks. The deployed database and personnel asset visibility data establishes the strength baseline. The S1 maintains unit status using manning updates primarily through standard unit reporting.

(4) **Assessing.** The S1 matches current and projected assets required to fight, maintain operations tempo (OPTEMPO), and achieve operational success. The S1 then determines the personnel required to maintain combat power in accordance with the commander's priorities and intent. He then recommends to the commander the method for individual personnel replacement.

(5) **Adjusting.** While predictive manning is critical to sustaining the future fight, all human resource leaders must be able to adjust manning plans quickly based on changing needs or capabilities and to support the commander's intent.

b. **Task Force Actions.** When soldiers deploy to an area of operations, the battalion S1 manifests soldiers to create the deployed database. Once the S1 establishes that baseline, units can report changes (exception reporting) to the baseline through personnel situation report (PERSITREP).

c. **Task Force S1 Responsibilities.** The S1 is the commander's principal staff officer for PSS. He advises the commander on human resource support matters. FM 12-6 establishes the foundation for the personnel support activities of personnel organizations (including S1 sections) and authorities. The S1 coordinates personnel services, personnel support, finance services, chaplain activities, command information services, medical services, and legal services support. He prepares the unit personnel service support SOP. In conjunction with the S4, he also prepares the administration and logistics (A/L) portion of the unit tactical orders. He participates in the OPORD process and develops personnel service support annex materials. He coordinates personnel service support with other staff elements and pays particular attention to mortuary affairs and medical support.

d. **Additional Services.** Personnel (S1) sections provide additional services at home station. When deployed, the S1 performs postal operations, essential personnel services (awards, promotions, evaluations, reassignments, and military pay), and MWR support. To maximize this capability, personnel systems, to include TPS, ITAPDB, and the CSSCS personnel module, may be required.

(1) **Before Operations.** The S1 creates a deployed database through the manifest process. Before deployment, the S1 receives a download of all deploying personnel in the units and uploads this data into TPS. The S1 or personnel service detachment (PSD) uses TPS, CSSCS, and the manpower requirements criteria (MARC) identification (ID) card

that all deploying soldiers possess to compile a manifest of personnel. A member of the manifest team operates a TPS terminal on the on-ramp of the transportation asset. As each person enters the gateway, he inserts his ID card into a scanner. The scanner reads the identification card bar code and identifies the personnel being deployed. Using the manifests from the different serials, TPS creates the task force's deployed database. After completing the manifest, the S1 produces the deployed personnel roster. The deployed personnel roster contains the name, grade, battle roster number, duty military occupational specialty (DMOS), gender, and unit of each individual manifested. TPS sorts this roster by last name and first name. Key personnel players use this roster to obtain personnel information on soldiers. The primary use is to determine a battle roster number for soldiers, which enables the completion of duty status reports.

(2) ***During Operations.*** As casualties occur, the platoon sergeant informs the company team first sergeant of the casualty via the most expedient method available (FBCB2 or FM voice). Using the personnel situation report, the first sergeant submits a duty status change directly to the S1 on all casualties. Attached elements report to the supported unit for manning activity requirements. Throughout this process, the S1 can monitor, assess, and adjust the command's personnel status.

(3) ***After Operations.*** The S1 reviews updated personnel strength figures through FBCB2 or TPS and reorganizes units based on the commander's assessment from the strength data. The S1 also uses TPS data information to decide where to return soldiers to duty or assign replacements. He uses by-name accountability to monitor his manning requirements. (In the future, defense integrated military human resources system (DIMHRS) will provide data to strategic assignment systems.) The S1 updates duty status changes through FBCB2 or TPS. The S1 depends on his TPS database for detailed personnel data.

### **Section III. COMBAT SERVICE SUPPORT PLANNING**

The S4, S1, and XO are the principal CSS planners. If operating under Force XXI, the FSC support operations officer also plays a role in the planning process. The XO, operating from the task force main CP, monitors CSS operations and ensures appropriate synchronization of support. The S4 and S1 and the HHC/FSC commander maintain a continuous CSS estimate during all operations. They use the CSS estimate to determine CSS capabilities, anticipate support requirements, identify and resolve shortfalls, and develop support plans. They integrate all planning to develop and synchronize CSS with maneuver and fire plans. CSS planners must thoroughly understand the mission, tactical plans, and task force commander's intent. They must know the following information:

- Mission, task organization, and concept of operations for all subordinate units in the task force.
- Brigade CSS plans.
- Known and anticipated branch plans and sequels.
- The density of personnel and equipment of each subordinate unit.
- Known and anticipated enemy situation and capabilities.
- Unit basic loads.
- Mission-related consumption rates.



## 10-12. PLANNING OVERVIEW

CSS planners must understand the task force's current and projected CSS capabilities. They use information collected from operational, personnel, and logistics reports to determine the personnel, equipment, and supply status of each unit within the task force. They consider the disposition and condition of all supporting CSS units as well as individual unit-level capabilities. They analyze this data and the current situation to determine the task force's logistical capabilities and limitations. This data is provided to the commander in the form of a logistics estimate.

## 10-13. LOGISTICS ESTIMATE

A logistics estimate is an analysis of logistics factors affecting mission accomplishment. Logistics planners use these estimates to recommend courses of action and to develop plans to support selected concepts of operation. The key concerns of task force logistics planners are the status of supply Classes III, IV, and V and the operational status of tanks, BFVs, and other combat vehicles. Logistics estimates at the task force level are rarely written. They are frequently formulated in terms that answer the following questions:

- What is the current and projected status of maintenance, supply, and transportation?
- How much of what is needed to support the operation?
- How will it get to where it is needed?
- What external (FSB) support is needed?
- Can the requirements be met using LOGPAC operations or are other techniques necessary?
- What are the shortfalls and negative impacts?
- What courses of action can be supported?

a. CSS planners must anticipate and understand the support requirements of a tactical plan or COA. The S4 analyzes all COAs and modifications to current plans. He assesses their sustainment feasibility, identifies support requirements, and determines requirements for synchronization. The S4, like the commander, must visualize how the battle will unfold in order to determine critical requirements for each sustainment function. He logically considers the requirements for each sustainment function during the operational phases of before (prior to commitment), during (commitment to battle), and after (reconstitution and future missions). He analyzes each COA or plan and considers--

- Type and duration of the operation.
- Task organization, tasks, and CSS requirements of subordinate forces.
- Ramifications of tactical operations such as river crossings, tactical pauses, long movements, preparatory fires or defenses.
- Need for special equipment, supplies, or services.
- Requirements to separate, disassemble, reconfigure, uncrate, or transload supplies above normal requirements.
- Requirements for reconstitution.
- Required varieties and quantities of all classes of supplies, especially III, V, and IX.
- Requirements for support of reconnaissance forces, security operations, or deception efforts.

- Need for Class IV and V obstacle material.
- Prepositioned stockage requirements.
- Emergency resupply requirements.

b. The S4's analysis also includes estimated attrition based on likely outcomes of subordinate missions. Analysis of estimated attrition primarily focuses on critical systems such as tanks, M2s, ADA, and engineer systems. The S1 assists by projecting potential personnel losses. To perform this analysis, the S1 and S4 use current unit personnel and equipment densities, standard planning factors, the CSSCS COA planning function, historical data, or any combination of these. This projection helps the commander understand the potential losses and associated risks of each COA.

c. In order to understand the task force's capabilities and determine support requirements, CSS planners should apply a METT-TC analysis to the situation. The following paragraphs give an example of general CSS considerations for tactical operations.

(1) Mission considerations include--

- Task force mission and commander's intent.
- Concept of the operations.
- Higher headquarters' mission and concept of operation.
- Higher headquarters' concept of support.
- Type and duration of the operation.
- Commanders tracked items list (CTIL)
- Controlled supply rate.
- Required supply rate.

(2) Enemy considerations include--

- Enemy capabilities and tactics that could threaten CSS operations.
- Enemy avenues of approach.
- Enemy unconventional tactics that could threaten CSS operations.
- Anticipated number of EPWs.

(3) Troops and support available considerations include--

- Task force task organization to include supporting CSS units.
- Location and condition of all units, including CSS units.
- Current and projected status of personnel, equipment, and classes of supply.
- Availability and status of services.
- Unit-level CSS capabilities.

(4) Terrain and weather considerations include--

- Effects of weather and terrain on CSS operations.
- Additional CSS requirements of the task force due to weather and terrain.
- Condition of infrastructure such as roads and bridges.

(5) Time available considerations include--

- Impact on the ability to replenish supplies.
- Planning and preparation time for CSS units.
- Impact of time on support requirements and distribution methods.

(6) Civil considerations include--

- Host-nation support and contract services.
- Impact of civilian and refugee movement.

- Potential for hostile reactions by civilians against CSS operations.
- US (civilian) contractors on the battlefield.

d. The S4 must balance support requirements with available CSS capabilities. He considers existing stockages, anticipated receipts, capacities, and capabilities. He must assess the status of all sustainment functions required to support the task force and compare them to available capabilities. He identifies potential shortfalls and recommends actions to eliminate or reduce their effects on the operation.

e. When a CSS shortfall is identified, the CSS planning staff takes every action available to eliminate or reduce its effect. The staff must understand its potential impact on the force, the risk it presents to mission accomplishment, its duration, and what requirements exceed the unit's capabilities. It analyzes the shortfall to determine its cause (for example, battle losses, supply availability, resource availability, equipment, time, people, or distribution shortfall). The staff considers the following actions to resolve a shortfall:

- Shift supplies or assets by phase of the operation.
- Request support or an additional asset from higher headquarters.
- Use alternate distribution methods.
- Consider prepositioning supplies or attaching additional CSS capabilities to subordinate forces.
- Modify the COA or plan.

f. Based on the CSS estimate, the S4/S1 develops support plans. The overall CSS plan is briefly described in the concept of support. The concept of support provides all commanders and staff sections with a general understanding of the commander's priorities and how the operation will be logistically supported. Detailed CSS plans are outlined in a CSS annex to the OPORD or as part of a FRAGO. The HHC/FSC commander also issues an OPORD to all units under his control. The HHC/FSC commander, in conjunction with the S4 and XO, closely monitors the implementation of the CSS plan. He adjusts CSS operations or shifts resources to account for a change in METT-TC factors or to replace lost CSS capabilities.

#### **10-14. SUPPORTING OFFENSIVE OPERATIONS**

The main purpose of CSS in the offense is to **maintain the momentum of the attack**. If offensive momentum is not maintained, the enemy may recover from the shock of the first assault, gain the initiative, and mount a successful counterattack. Therefore, the CSS priority must be to maintain the momentum of the attack. A key part of the plan is the CSS overlay produced by the S4. The overlay ensures that both the supported units and the HHC/FSC know the location of all support assets in relation to the maneuver units and maximizes the support given. The CSS overlay can be sent digitally via FBCB2 or distributed manually. To maintain mobility and keep up with the maneuver units, the field trains or TFSA remains uploaded as much as possible. A well-defined SOP or plan should determine when and how the BSA and or TFSA move in relationship to the TF main body. The field trains/TFSA commander must maintain the lines of communication and supplies with the FSB; coordination with the FSB support operations section is critical. The HHC/FSC commander must be able to determine and recommend to the S3 the proper positioning and movement windows for the field trains/TFSA so uninterrupted support continues. The support/S&T platoon must be ready to push immediate resupply

forward quickly. Additionally, the task force combat trains should be postured to provide immediate maintenance and recovery support.

a. **Anticipate.** Logistics planners must be proactive in planning CSS operations. The CSS system must be flexible to support contingencies or future operations. Anticipating the task force's CSS requirements is crucial to maintaining the momentum of offensive operations. Some considerations for anticipating CSS in the offensive include the following:

- Increased consumption of Classes III, V, and IX.
- Resupply operations.
- Heavy requirements on task force transportation assets.
- An increase in equipment maintenance requirements.

b. **Class V.** Special considerations concerning Class V availability are necessary before and during offensive operations. Some of those considerations include the following:

- Ensure subordinate units are fully resupplied with Class V prior to the operation.
- The task force should carry additional stockage of critical ammunition.
- Use and request preconfigured combat loads.
- Ensure resupply of special Class V requirements.

c. **Maintenance Support.** The following are planning considerations for maintenance support in offensive operations:

- Ensure rapid repair and return of non-mission-capable equipment to support the operation.
- Establish command maintenance priorities based on what systems and units are critical to the success of the operation.
- Emphasize BDAR.
- Plan a series of maintenance collection points.
- Establish criteria for requesting additional recovery assets.
- Identify critical combat spares and have them ready to move forward on short notice.

d. **Medical Support.** Ineffective medical support during offensive operations can slow the advance and significantly detract from mission accomplishment. Some considerations in planning medical support include the following:

- Anticipate the potential of high casualty rates and decrease long evacuation times.
- Place attached or assigned FSB medical assets as far forward as possible.
- Ensure all company team ambulance squads have a full basic load of supplies before the operation begins.
- Position prepackaged sets of Class VIII supplies at the BAS.
- Position additional ground evacuation assets at the BAS.
- Ensure responsive medical support is established for task force scouts and other forward reconnaissance elements.
- Identify and coordinate AXP's along the axis of advance and on the objective.
- Identify nonmedical transportation assets to support mass casualty evacuation situations.

- Ensure integration of air ambulance support to include coordination of A2C2 requirements.
  - Establish clear lines of authority and criteria to execute a MEDEVAC mission.
  - Identify PZs and LZs along the axis of advance to support MEDEVAC operations.
- e. **Class III.** Immediate resupply of Class III is critical in offensive operations. Some planning considerations include the following:
- Ensure all units are topped off with fuel and are carrying their basic load of POL package products prior to execution.
  - Ensure all forward stocks are resupplied and the Class III point is prepared to move forward rapidly. Set up tactical refueling points and refuel-on-the-move (ROM) sites.
  - Plan refueling operations based on the consumption estimates for each individual company team and unit.
- f. **Synchronized Support.** The most successful operations are those that are synchronized. The following are considerations for the synchronization of support:
- Plan support and resupply operations based on anticipated support needs of each subordinate unit.
  - Integrate refueling and resupply operations with the scheme of maneuver to ensure proper timing and to avoid interfering with likely or planned maneuver actions.
  - Plan for refueling and resupply operations as far forward as possible in covered and concealed locations.
  - Plan triggers for activating and deactivating casualty collection points, ambulance exchange points, and LRPs based on the task force's scheme of maneuver.
  - Coordinate the locations, displacements, and routes of CSS assets and units to maintain responsive support.
  - Include security of the MSRs in the tactical plan to minimize the risk to support elements.
  - Ensure open lines of communications and coordination are maintained with the FSC and or FSB support operations section and the brigade movement control officer on all information regarding throughput deliveries.
  - When planning subsequent positions, consider throughput delivery schedules.
- g. **Security.** As discussed previously, CSS assets are vulnerable and may need security support. Possible security considerations include the following:
- Ensure adequate security of routes and CSS assets based on the potential threat of undetected enemy forces.
  - Conduct rehearsals so that dedicated security forces (if available) and CSS units are prepared for enemy contact.

- Anticipate the need for route clearance and reconnaissance to support the movement of wheeled vehicles based on the terrain and roads available. (This is especially true if CSS traffic moves across previous enemy positions that may contain obstacles and large amounts of unexploded ordnance.)
- Ensure CSS preparations for the mission do not give away tactical plans.

### **10-15. SUPPORTING DEFENSIVE OPERATIONS**

The aim of CSS activities in the defense is to support defensive preparations, security operations, and the main battle area engagement and to transition to subsequent missions. A plan for the support of the mobility, countermobility, and survivability effort in the task force's AO is critical. Class IV supplies should be pushed from corps directly to the emplacement site. Class V is given the highest priority of all critical supplies during defensive operations. The increased expenditures of ammunition significantly affect transportation assets. Use throughput supply to expedite deliveries as far forward as possible. As in offensive planning, the S4 prepares and distributes the CSS overlay. It includes MSRs, Class IV and V stockage points, and LRPs. In the defense, CSS units are positioned farther to the rear to avoid interfering with the movement of maneuver units between positions and the forward movement of the counterattack force. The following paragraphs describe CSS considerations during the defense.

a. **Anticipation of Requirements.** The following areas require proactive planning:

- Anticipate increased consumption of Classes IV, V, and VIII; a decrease in Class III requirements; and the potential for mass casualties.
- Establish mass casualty criteria for the task force and company team commanders.
- Anticipate the immediate requirement to replenish ammunition and provide additional ammunition stocks based on subordinate unit tasks.
- Anticipate that the demand for decontamination and chemical protection equipment may increase.
- Estimate the requirements for Class IV and V obstacle materials and push materials forward early to facilitate defensive preparations.
- Plan and allocate additional Class III and maintenance support for engineer assets during the preparation phase.

b. **Positioning.** CSS assets are most vulnerable in defensive operations. Properly positioning these assets can deter detection by the enemy. The following are considerations for positioning CSS assets:

- Avoid positioning CSS sites and units along enemy ground or air avenues of approach, in the vicinity of artillery units, or near templated enemy NBC target areas.
- Coordinate movement and terrain requirements with maneuver plans and the positioning of other units such as artillery.
- Position the field trains or TFSA and CSS units as far to the rear as possible but close enough to provide responsive support.
- Periodically move combat trains and other CSS assets, based on the threat level, to decrease their vulnerability of detection.
- Maximize the use of cover and concealment, dispersion, and the protection provided by the terrain.

c. **Avoiding Patterns.** Creating patterns of support increases the risk to CSS units. Some recommendations include the following:

- Avoid setting patterns of support in order to decrease vulnerability to enemy interdiction.
- Vary LOGPAC times and LRP locations.
- Consider conducting LOGPACs and other routine CSS activities during limited visibility.
- Maintain OPSEC.

d. **Providing Support in Depth.** The CSS structure must support the entire defense. Suggested ways to accomplish this include the following:

- Ensure the initial focus of support is to the defensive preparation effort.
- Ensure maintenance, resupply, and evacuation plans support security forces and forward reconnaissance assets. As the battle develops, the CSS priorities normally shift to support the task force's main battle area.
- Ensure MSR support the entire scheme of maneuver to include all contingencies, subsequent positions, and counterattack options.
- Plan alternate and contaminated MSR for contaminated equipment and casualties to provide flexibility.
- Develop and rehearse triggers for the movement, displacement, and evacuation of CSS sites based on the enemy situation and the scheme of maneuver.

e. **Classes IV and V (Obstacle Material).** The proper placement and resupply of obstacle materials is critical to a successful defense. The following are some placement and handling considerations:

- Identify Class IV and V requirements to support company teams and directed obstacle belts early in the planning process.
- Identify locations of task force Class IV and V points early by coordinating with the engineer company.
- Push materials forward as soon as possible.
- Ensure Class IV and V points are centrally located to support directed obstacle belts while remaining concealed from the enemy.
- Ensure material-handling equipment is positioned at each Class IV and V point.
- Coordinate sufficient maneuver support to organize materials and uncrate mines, cut overhead cover for fighting positions, and load material onto haul assets.
- Closely track the usage of Class IV and maintain the flexibility to shift materials based on refinements to the plan, changes in the situation, and the progress of obstacle construction.
- Plan to withdraw unused Class IV and V supplies based on an event trigger to prevent the loss of unused materials.
- Consider attaching additional transportation assets to engineers to support the movement of obstacle materials to construction sites.
- Maximize the use of corps throughput to transport Class IV and V supplies directly to task force Class IV and V points.

f. **Class V.** Improperly resupplying Class V in defensive operations will result in failure. Some planning considerations include the following:

- Push as much Class V forward as possible based on the commander's priorities of support and the anticipated ammunition requirements of each unit.
- Prestock ammunition at primary and subsequent positions and ensure it is properly guarded and stored.
- Ensure the resupply plan supports specialized ammunition requirements of all units, such as ADA and engineers.
- Maintain emergency resupply stocks within the combat trains and with the field trains/TFSA in depth.

g. **Maintenance Support.** Responsive maintenance support speeds up the return of essential combat systems to battle. Maintenance planning should include--

- Maintenance priorities approved or established by the commander.
- Maintenance teams dispatched as far forward as possible to reduce the requirement to evacuate equipment. The thrust of the maintenance effort is to replace forward and fix rear.
- Rapid evacuation of damaged equipment from the UMCP to the BSA in the event defending forces must reposition.

h. **Medical Support.** Medical support planning is critical to provide rapid treatment and avoid confusion. The following are planning factors for medical support:

- Position AXP's and medical evacuation assets to support timely casualty movement.
- Coordinate evacuation routes and plans with maneuver plans and obstacle locations.
- Develop a contingency plan for the loss of one or both aid stations.
- Ensure medical support to CS and CSS elements such as C2 facilities, engineers, ADA, and communication nodes.
- Maximize the use of nonstandard ambulances to replace lost ambulances or provide additional evacuation support.
- Always plan for mass casualties and ensure that adequate evacuation means, to include air transportation, are identified and rehearsed.

#### **10-16. ECHELON OF THE TRAINS**

Under AOE, the task force CSS assets are normally echeloned into company combat trains, task force combat trains, and task force field trains. The combat trains are organized to provide immediate critical support for the combat operation and are controlled by the task force S4. Field trains are normally in the BSA and under the control of the HHC commander, who coordinates with the forward support battalion commander for security and positioning. Under Force XXI, the trains are echeloned into combat trains under the control of the HHC commander and a task force support area under the control of the FSC commander.

a. The most forward CSS elements are the company team combat trains. A medical evacuation team (routinely attached to the company) and the company maintenance team tracked vehicles, when forward, form the company team trains. The company team first



sergeant positions these elements, tasks the medical evacuation team, and establishes priority of work for the company maintenance team.

b. When operating in echeloned trains, the company team supply sergeant usually operates from the field trains or from the TFSA. Coordination between the company team supply sergeant and the first sergeant is conducted through the CTCP over the A/L net or FBCB2 and is supplemented by face-to-face coordination during LOGPAC operations.

c. The task force combat trains normally include the CTCP, BAS and other medical platoon elements, decontamination assets, all uploaded Class III and V vehicles, elements of the communications platoon, and the UMCP along with some supporting elements from the FSB such as the FSC support operations cell. The combat trains are controlled by the S4 under AOE and the HHC commander under Force XXI; either is assisted by the S4. Elements of the combat trains operate on the A/L net and are linked to the company team 1SGs via FBCB2, if equipped.

d. The task force combat trains should be close enough to the FLOT to be responsive to the forward units but not within range of enemy direct fire. The combat trains can expect to move frequently to remain in supporting distance of the combat elements. The following factors govern the positioning of the combat trains.

(1) Communications are required between the CTCP, the main CP, the field trains CP (or TFSA CP), brigade rear CP, and forward units.

(2) Room for dispersion and cover and concealment from both air and ground observation are desired.

(3) The ground must support vehicle traffic.

(4) A suitable helicopter landing site should be nearby.

(5) Routes to logistical release points or to company team positions must be available.

(6) Movement into and out of the area must not be restricted.

e. Built-up areas are good locations for trains. They provide cover and concealment for vehicles and shelter that enhances light discipline during maintenance. When built-up areas are used, task force trains elements should occupy buildings near the edge of the area to preclude being trapped in the center.

f. The UMCP is established and supervised by the BMO to provide forward maintenance support to the task force. It is normally located near or within the task force combat trains. The UMCP and task force combat trains may combine to form a base cluster for defense.

g. Under AOE, the field trains are usually in the BSA and are controlled by the HHC commander. Generally, the field trains include the PAC, the mess sections, the company supply sections, the HHC command post, and the remainder of those elements of the maintenance and support platoons that are not forward. Under Force XXI, the task force consolidates CSS within a task force support area located 4-12 kilometers from front line combat units. The TFSA is commanded by the FSC commander and includes the assets that under AOE had been positioned in the field trains.

h. The BSA is that portion of the brigade rear area occupied by the brigade rear CP, the FSB, and the task force field trains. CSS assets in the BSA include elements from the FSB, maneuver and combat support unit field trains, and selected corps support command (COSCOM) and division (DISCOM) resources, as required.

### 10-17. MOVEMENT OF THE TRAINS

The task force commander directs the movement of combat and field trains in the task force OPORD. The XO and S4 plan the execution of the movement of the trains (or the FSC) to ensure responsive forward support. The displacement of the field trains or TFSA must be carefully coordinated with the tactical scheme of maneuver, location of the BSA and MSRs, communication links, establishment of digital nodes, priorities of support, and time available for corps throughputs and displacement. It is important for the task force staff to understand the impact of corps throughput delivery schedules during the planning process. Movement of the trains or the FSC may severely constrain the maneuver commander's plan unless each echelon of CSS is considered during the planned or emergency move.

a. Security of CSS assets is a major consideration. The task force has sufficient transportation assets to move its CSS personnel and equipment in one lift. However, downloaded supplies at supply points and disabled equipment at maintenance sites create mobility problems. The task force staff must closely monitor mobility status and anticipate mobility problems well in advance to develop solutions. For all additional transportation requirements beyond the task force's capability, the S4 must coordinate for external support with the FSB support operations section.

b. In addition to conducting planned moves, both the combat trains and the field trains (or TFSA) should have an SOP for conducting emergency moves. Emergency moves normally occur when the trains or support area must relocate quickly to avoid a significant enemy threat. The task force designates alternate trains/TFSA locations and sufficient movement routes. Alternate trains/TFSA locations should be coordinated with the XO, staff, and the FSB commander of the impending move.

c. SOPs and CSS operational logistics (OPLOG) plans ensure adequate means are employed to detect enemy threats early enough to avoid loss of the task force's CSS capabilities. The combat trains, field trains, or FSC commander disseminate emergency movement plans to all task force CSS elements in an OPORD. Leaders reconnoiter movement routes and alternate locations to ensure suitability. Emergency plans are rehearsed as time allows.

(1) ***Movement of Trains within the TF Formation.*** This technique is used when the likelihood of enemy contact is minimal, logistical demands are light, and the task force (or separate units) can use basic loads and organic recovery assets to satisfy initial requirements. Sufficient time must be allowed for the field trains or TFSA to establish services and resupply from the FSB prior to mission execution. HHC or FSC elements are dispersed within march columns and are secured by other elements of the task force. This technique provides timely movement and march security but precludes any meaningful support until movement ceases. This technique may be useful during tactical road marches or approach marches.

(2) ***Support from BSA Displaced as an Entity.*** When brigade operations are conducted in clearly defined phases with identifiable windows between phases (such as in river crossings) the FSB may support the brigade from a fully deployed BSA that includes the HHCs/FSCs and then displace as an entity to subsequent TFSA or BSA locations. This allows the FSB to maximize support from a mature logistical base that facilitates resupply and maintenance activities. This concept also enhances command and control of the FSB and simplifies actions for supported forces since a single point of

contact is established for each service and facility of the BSA. Because displacing the BSA as an entity affects the quality of support, echelon displacement may be the preferred method.

(3) ***TFSA Displacement by Bounds.*** Force XXI allows for a unique capability when operations require continuous logistical support. Critical CSS assets are divided and displaced by successive bounds from one TFSA location to a new TFSA location. The FSC commander normally moves with the forward logistics element (FLE) to ensure rapid setup of the displacing echelon. This technique provides more responsive support by minimizing the throughput distances to FSC elements. It also enhances the survivability of logistical assets by positioning them in different areas. Because of echelonment, C2 of the FSC operations may be degraded. A heavy reliance on unit SOPs, communication links, and OPLOG plans is vital to ensure smooth displacement of the FSC.

## **10-18. LOGPAC OPERATIONS**

The most efficient resupply of forward task force units is accomplished by logistics packages.

a. LOGPACs are organized in the field trains or TFSA by the company supply sergeant under the supervision of the HHC or FSC commander and the support/S&T platoon leader. LOGPACs are organized for each company team and separate element in the task force and moved forward at least daily for routine resupply. When possible, all LOGPACs are moved forward in a march unit under the control of the support/S&T platoon leader. Special LOGPACs are organized and dispatched as required by the tactical situation and logistical demands.

b. The S4 must plan and coordinate LOGPAC operations to ensure that they fully support the commander's tactical plans.

c. Task force SOP establishes the standard LOGPAC. Normally, a company team LOGPAC includes the following elements.

(1) ***Unit Supply Truck.*** This vehicle contains the Class I requirements based on the ration cycle--normally one hot meal and two meals, ready to eat, (MREs) per man. The supply truck tows a water trailer and carries some full water cans for direct exchange. In addition, the truck carries any Class II supplies requested by the unit, incoming mail, and other items required by the unit. The truck may also carry replacement personnel.

(2) ***POL Trucks.*** Bulk fuel and packaged POL products are on these vehicles.

(3) ***Ammunition Trucks.*** These vehicles contain a mix of ammunition for the weapons systems of the company team. Unit SOP establishes a standard load; reports and projected demands may require changes to this standard load.

(4) ***Vehicles Carrying Additional Supplies and Replacements.*** These vehicles join the LOGPAC as coordinated by the support platoon leader and supply sergeant.

d. LOGPACs for platoon-sized attachments are usually loaded on a single truck. Water and Class III resupply is often accomplished by using 5-gallon cans and pods mounted on trailers.

e. When the company team LOGPAC has been formed, it is ready to move forward under the control of the supply sergeant. The support/S&T platoon leader normally organizes a convoy for movement of all company LOGPACs under his control; in emergencies, he dispatches unit LOGPACs individually. The convoy may contain additional vehicles such as a maintenance vehicle with Class IX to move to the UMCP or

an additional ammunition or fuel vehicle for the combat trains. The LOGPACs move along the MSR to a logistics release point, where the unit first sergeant or a unit guide takes control of the company LOGPAC.

f. From the LRP, the company first sergeant or guide controls the LOGPAC and conducts resupply as described in FM 3-90.1. The unit first sergeant informs his supply sergeant of requirements for the next LOGPAC. The supply sergeant collects outgoing mail, personnel, and equipment for movement to the rear. The LOGPAC then follows unit SOP and returns to the LRP, field trains, or TFSA.

g. LRP locations are determined by the S4 based on the tactical situation. They should be well forward and easily located. Normally, two to four LRPs are planned. LRPs, as well as the MSR, combat trains, and field trains and or TFSA locations are included on the operations overlay, if possible. The CTCP notifies subordinates and the field trains/TFSA CP well in advance which LRP(s) will be used. The LOGPAC convoy arrival time at the LRP and the length of time it remains normally are established by SOP. If the tactical situation dictates otherwise, the S4 must determine the time and notify units accordingly. LOGPACs may be scheduled to arrive shortly after arrival at a BP or intermediate objective. Armor units will also require more frequent Class III resupply. Subordinates must ensure that the resupply vehicles are returned to the LRP as soon as possible so that the vehicles can return to the field trains and begin preparation for the next mission. Class III and V vehicles never sit empty. If the LOGPAC cannot be completed on schedule, the CTCP must be notified.

h. At least one senior representative from the combat trains (S4, S1, or senior NCO) should be present at the LRP while it is in effect. His purpose is to meet with the unit first sergeants and support/S&T platoon leader for coordination of logistical requirements and to ensure that the LOGPAC release and return takes place efficiently. A brief meeting is normally held immediately before the first sergeant picks up his LOGPAC. Coordination may include--

- Changes in logistical requirements reflecting any last-minute task organization.
- Reports on personnel, logistics, and maintenance from the first sergeants.
- Confirmation of receipt of digital LOGSITREPs (if FBCB2 equipped)
- First hand updates on the tactical situation and logistical status.
- Delivery, receipt, and distribution of unit mail.

i. The company team supply sergeant or support platoon leader moves the LOGPAC from the LRP back to the field trains/TFSA. The supply sergeant and support platoon leader then begin organization of the next LOGPAC.

j. Resupply of the scout and mortar platoons, the main CP, combat trains, and attached support units must be planned and coordinated. The HHC first sergeant coordinates and supervises resupply of these elements. Under AOE, the HHC first sergeant operates near the task force main CP when forward and at the field trains CP upon completion of daily resupply. Under Force XXI, the HHC 1SG operates out of the task force combat trains.

(1) The platoon sergeant of these elements or senior NCO at a facility must report his requirements to the HHC first sergeant or to the combat trains CP. The most desirable method of resupply is to form small LOGPACs for these elements, which the platoon sergeant picks up at the LRP in the same manner as a company first sergeant.

Attachments larger than a platoon must come to the task force with sufficient CSS vehicles to carry their LOGPACs.

(2) In some cases, the HHC first sergeant delivers the LOGPAC to the main CP, combat trains, and scout and mortar platoons. Attachments can receive resupply at one of these locations or as previously coordinated.

(3) Another option is for attachments to be resupplied from a nearby company team LOGPAC. The S4 coordinates this resupply **before** the LOGPACs are dispatched.

(4) Resupply operations for the scout platoon pose several unique problems. Special procedures may be necessary to resupply the scout platoon, to include--

- Resupplying the platoon by having each track individually pull off line and move to a resupply site. (This method may be feasible when the platoon is performing security for a stationary force.)
- Resupplying the platoon near the combat trains as the platoon repositions between missions.
- Designating one Class III vehicle in the combat trains to fuel the platoon on short notice.

k. Units in direct support or under OPCON of the task force are responsible for the coordination of resupply of their elements operating forward with the task force, except as noted.

(1) The ADA battalion or battery commander coordinates for the task force to resupply ADA units in direct support with some classes of supply. This may be directed in higher headquarters' SOPs and usually includes Class I, III, and V, and common item IX.

(2) The task force provides engineer materials (Classes IV and V) to supporting engineer units. Additionally, engineer units under OPCON of the task force receive Class I, III, V, and IX support to the maximum extent possible. This support is coordinated through or directed by brigade before the OPCON directive becomes effective.

(3) The parent unit S4 or company commander of the supporting element coordinates with the task force S4 or HHC commander on resupply of the forward elements. Normally, the supporting units' resupply elements assemble in the BSA and move to the task force field trains area. The HHC commander then dispatches these resupply elements forward, along with the task force LOGPACs, to the LRP. At the LRP, the platoon sergeant of the forward supporting element takes control of the resupply element. These resupply elements maintain contact with the combat trains CP while forward in the task force area. If coordinated between the supporting parent unit and the task force, the resupply of these forward elements is directly managed by the task force. The parent unit must provide the additional logistical assets necessary to supplement the task force's capabilities. No matter how support was coordinated, any element within the task force area of operation must either be under the task force commander's control or at least remain in contact with the task force combat trains CP to avoid interfering with task force maneuver.

l. While the LOGPACs are the preferred methods of resupply, there will be times when other methods of resupply are required.

(1) ***Resupply from the Combat Trains (Emergency Resupply)***. The combat trains have a limited amount of Class III and V for emergency resupply. The S4 coordinates

emergency resupply from the combat trains and then refills or replaces the combat trains' assets.

(2) **Prestocking.** Prestocking is the placing and concealing of supplies on the battlefield. This is normally done during defensive operations when supplies are placed in subsequent battle positions.

(3) **Mobile Prepositioning.** This is similar to prestocking except that the supplies remain on the truck, which is positioned forward on the battlefield

#### **10-19. TRAINS AND FSC SECURITY**

CSS elements behind the FLOT form base clusters and must be prepared to defend themselves against guerrillas and partisans and forces that have broken through or bypassed the defense.

a. Under AOE, the S4 is responsible for trains security when operating in a unit trains configuration. When trains are echeloned, the S4 is responsible for securing the combat trains, and the HHC commander is responsible for securing the field trains. If the task force commander collocates his field trains with the BSA, the HHC commander coordinates with the FSB commander and brigade rear CP to integrate the task force field trains into the BSA defensive plan. When CSS is consolidated under the Force XXI concept, the FSC commander is responsible for CSS security.

b. A perimeter defense is normally planned in all trains areas, and elements in the trains are assigned a specific sector to defend. Mutually supporting positions that dominate likely avenues of approach are selected for vehicles armed with heavy machine guns. Reaction forces and OPs are established based on the unit SOP. To enhance security, an alarm or warning system is arranged. Sector sketches, fire plans, and obstacle plans should be prepared. Rehearsals are conducted to ensure that all personnel know the part they play in the defensive scheme. The OIC at each location establishes a shift schedule for operations and security on a 24-hour basis

#### **10-20. COMMAND AND CONTROL**

CSS command and control is the responsibility of the task force XO. The S4 routinely coordinates all logistics operations, based on the XO's guidance. Command and control facilities are the CTCP and the field trains/TFSA CP.

a. The CTCP includes the S4 CP carrier (M1068) (with enough S1 and S4 personnel cross-trained to ensure continuous operation) and the communications platoon (M1068) and personnel. Under Force XXI it will also include the FSC support operations (M1068). The combat trains must stay abreast of the tactical situation and task organization; monitor the task force command net to identify CSS requirements; and receive requests, reports, and requirements from task force subordinate elements. Subordinate requirements are analyzed, consolidated, and forwarded to the field trains or TFSA CP or to the appropriate supporting agency. The HHC/FSC commander coordinates and directs elements in the field trains/TFSA to take action to meet the forward units' requirements.

b. The field trains/TFSA CP is the coordination and control center for the support/S&T platoon, PAC, maintenance platoon (-), and the task force and company team supply sections. Personnel from these sections operate the field trains/TFSA CP under supervision of the HHC/FSC commander. The HHC/FSC commander coordinates

all requirements for task force organic and attached elements with all units in the BSA/TFSA and parent units as necessary.

### **10-21. COMMUNICATIONS**

At task force level, CSS communications may be by any combination of FM radio, digital connectivity, courier, or wire. Under AOE, the A/L radio net is used for most CSS traffic. Under Force XXI, FBCB2 is the primary means of CSS communication.

a. The CTCP is the NCS for the A/L net. The S4, S1, HHC/FSC commander, BMO, support platoon leader, medical platoon leader, company first sergeants, and others (as required) operate in the task force A/L net. The combat trains CP also operates in the brigade A/L net and in the task force command net.

b. Communications are critical to expedite the CSS effort. Unit first sergeants must report their losses and requirements as soon as practical. When use of radio or FBCB2 is not possible, messages are sent with resupply or evacuation vehicles. The CTCP and field trains/TFSA CP maintain control of vehicles moving forward to the LRPs. Task force SOP establishes procedures for resupply without request in the event communications fail

## **Section IV. RECONSTITUTION**

Planners must be prepared for mass casualties, mass destruction of equipment, and the destruction or loss of effectiveness of entire units. This section discusses reconstitution and shows how the task force or company teams that have been catastrophically depleted or rendered ineffective are returned to combat effectiveness. Reconstitution consists of the actions to restore companies to a desired level of combat effectiveness commensurate with mission requirements and availability of resources. Reconstitution differs from sustaining operations in that it is undertaken only when a unit is at an unacceptable level of combat readiness. Sustainment operations are routine actions to maintain combat readiness. Commanders reconstitute by either reorganization or regeneration.

### **10-22. REORGANIZATION**

Reorganization is the action taken to shift resources within a degraded company team to increase its combat power. Measures taken include cross-leveling equipment and personnel, matching operational weapons systems with crews, or forming composite companies.

a. Immediate battlefield reorganization is the quick and often temporary restoration of companies conducted during an operation; for example, reorganizing on the objective and implementing the established succession of command.

b. Deliberate reorganization is a permanent restructuring of the unit. It is the type of reorganization considered during reconstitution planning. Deliberate reorganization is supported with higher echelon resources (such as maintenance and transportation), and additional replacements and other resources may be made available. Deliberate reorganization must be approved by the parent-unit commander one echelon higher than that reorganized. For example, the task force commander cannot approve the deliberate reorganization of an attached company, but the parent battalion commander or the brigade commander can approve it.

### **10-23. REGENERATION**

Regeneration is incremental or whole-unit rebuilding through large-scale replacement of personnel, equipment, and supplies; reestablishing or replacing essential command, control, and communications; and conducting the necessary training for the rebuilt unit. The unit must be removed from combat to be regenerated. Divisions regenerate battalions or companies; corps regenerate brigades or battalions. To regenerate a unit, the division or corps commander must balance priorities for supplies, equipment, or other CSS, and he must task the support organizations to provide direct support



## CHAPTER 11

# COMMAND POST OPERATIONS

*Echeloned command and control facilities control battalion task forces with varying levels of staff participation at each echelon. The TF command group operates forward and consists of the commander and those selected to go forward to assist in controlling maneuver and fires during the battle. The commander determines the composition, nature, and tasks of the command group based on METT-TC analysis. As a minimum, the command group--*

- *Integrates combat assets in support of close operations.*
- *Controls close operations.*
- *Maintains situational understanding.*
- *Provides close situation information to the main CP.*

*The commander and S3 monitor the battle, develop the situation, analyze courses of action, and control the company teams.*

### Section I. COMMAND AND CONTROL FACILITIES

Battalion task force command and control facilities consist of the vehicles and locations from which the TF commander, assisted by staff, directs the battle and sustains the force. These facilities include the main command post, the tactical command post, the combat trains command post, task force support area command post or the field trains command post.

#### 11-1. COMMAND GROUP

The command group accompanies the commander forward to assist with command and control of the battle. The composition of the command group depends on the situation and the desires of the commander. The command group generally consists of the commander, S3, FSO, ALO, and crews from the assigned tracked vehicles. There is no requirement for these leaders to collocate; the commander may be in one part of the TF AO while the S3, for example, is in a separate part of the AO.

a. The command group is not a permanent organization and is normally prescribed by SOP and modified as necessary. The command group is highly mobile, enabling the commander to move about the battlefield as necessary. It is normally activated and employed only for the actual conduct of the battle, with the battalion TOC controlling the TF during other periods.

b. The command group fights the battle. The commander positions himself so that he can “see the battle” and issue appropriate orders at critical times. “Seeing the battle” does not mean simply positioning the command group in a location to observe decision points and critical actions. It also implies that the command group is in a position to receive reports on those key indicators that the commander has discussed with his subordinates and that, upon receipt of these reports, the commander is in a position to order decisive action. The FSO must be in a position to coordinate indirect fires and respond to changes in the situation or mission with recommended changes to the fire support plan. The ALO must be in a position to see the battlefield in order to coordinate

close air support, shift preplanned CAS targets, and advise the commander on CAS issues.

c. The command group normally operates in two to three armored vehicles modified for command and control. The crews of the tracked vehicles in the command group assist in operating radios, posting maps, moving the vehicles, and providing security, thus freeing the commander and S3 to concentrate on the battle.

### **11-2. MAIN COMMAND POST**

The main CP includes the designated soldiers, equipment, and facilities employed in commanding and controlling the TF. The primary considerations in positioning the main CP are survivability, communications, and accessibility. Main CP vehicles and personnel must be as few as possible to allow rapid displacement, but numerous enough to accomplish command and control functions in support of the commander. The personnel who operate the main CP must be organized to provide both security and operations on a 24-hour basis. This requires enforcement of a sleep plan to preserve the ability of main CP personnel to perform continuous operations. (See Appendix D, Section III.) An internal set of SOPs must establish the organization and operation of the main CP. The main CP must maintain continuous communication and coordination with the company teams. (Refer to Appendix I for examples of charts that can assist in C2 and in maintaining information as to the current status of the battlefield.) The tactical operations center is an integral part of the main CP and is the control, coordination, and communications center for TF operations. The TOC consists of the S2 and S3 sections, the FSE, representatives from other attached elements, and the command group (when this group is not located forward). The TOC--

- Maintains contact and coordination with higher and adjacent headquarters.
- Synchronizes close operations, integrating CS and CSS into the maneuver plan.
- Analyzes and disseminates tactical information concerning both enemy and friendly situations.
- Plans future operations.
- Receives tactical and logistical status reports.
- Serves as alternate for the main CP command group.

### **11-3. COMBAT TRAINS COMMAND POST**

The CTCPC is the coordination center for combat service support for the battalion task force. Depending on the type organization, the S4 or HHC commander is responsible for operations, movement, and security of the combat trains. The S4 or HHC commander continually assesses the situation, anticipates the needs of units, and prepares to push support forward. Anticipating requirements is the key to successful combat service support. The CTCPC needs an internal SOP to govern its operation and to outline duties of the personnel manning it.

a. The combat trains command post has the following functions:

- Plans and coordinates sustainment for tactical operations.
- Serves as alternate for the main CP.
- Prepares to shift support if the main effort changes.
- Monitors the ability of the CSS system to support the operation.

- Reports to the main CP any change in the ability of the CSS system to support the operation.
- Maintains logistics status reports on all organic, attached, combat, CS, and CSS units operating with the TF.
- Aggregates the reported logistics data to report to higher headquarters.
- Ensures personnel accountability of all assigned or attached TF personnel.

b. The S4 assesses the logistical posture of maneuver units, anticipates requirements, and pushes support forward as the tactical situation permits. The S1 monitors the tactical situation and relays MEDEVAC requests to the task force aid station. The S1 uses this information to initiate personnel replacement operations.

c. The CTCP also monitors the current tactical situation on the command net to assume its function as the alternate main CP. Tactical situation maps and charts are continuously updated based on information gathered from these sources.

#### **11-4. TASK FORCE SUPPORT AREA COMMAND POST (FORCE XXI)/FIELD TRAINS COMMAND POST (AOE)**

The task force support area command post in Force XXI organizations and the field trains command post in AOE organizations perform the same functions. The principal difference between the two command posts is the organization from which the personnel are derived. In Force XXI organizations the TFSA CP is commanded by the FSC commander and is located between the CTCP and the BSA. In AOE organizations, the FTCP is commanded by the HHC commander and when the TF commander collocates his field trains with the BSA, the HHC coordinates with the FSB commander for positioning and defensive responsibilities within the BSA. In some cases the FTCP may be located independent of the BSA; in this situation, the TF S-3 designates the general location for the field trains.

a. The TFSA CP (Force XXI organizations) is composed of the FSC commander, FSC 1SG, HHC XO, and the remaining elements of the S-1 and S-4 sections. It coordinates the collection and movement of CSS from the TFSA to forward elements of the TF. It controls and coordinates activities of the TFSA, including operations of the S&T platoon, elements of the maintenance platoon, company team supply sergeants, and the PAC. The TFSA CP monitors the task force A/L net and maintains an FM and digital communications link with the FSB.

b. The FTCP (AOE organizations) is composed of the HHC commander, XO, 1SG and the remaining elements of the S-1 and S-4 sections. It coordinates the collection and movement of CSS from the task force field trains and the FSB to the forward elements of the TF. It controls and coordinates the activities of the TF field trains, including operations of the support platoon, elements of the maintenance platoon, company team supply sergeants, and the PAC. The FTCP monitors the task force A/L net and maintains FM and land line communications with the FSB.

c. In both Force XXI and AOE organizations, LOGPACS are formed by the FSC/HHC commander and delivered by the S&T/support platoon and company supply sergeants. The TFSA CP or FTCP is responsible for organizing and dispatching the LOGPACS to the forward units.

### 11-5. COMMAND POST SURVIVABILITY

CP survivability depends mostly on concealment and mobility. The best way to protect a CP is to prevent the enemy from detecting it. Good camouflage and proper noise, light, and signal discipline enhance the security provided by a good location.

a. **Location.** The best place for CPs is in built-up areas. When necessary, a CP not in a built-up area should be located on a reverse slope with cover and concealment. Avoid key terrain features such as hilltops and crossroads. Locate CPs on ground that is trafficable, even in poor weather. Other considerations for positioning CPs include--

- Ensuring line-of-sight communications with higher, lower, and adjacent units.
- Avoiding redundancy of communications.
- Masking signals from the enemy.
- Using terrain for passive security (cover and concealment).
- Collocating with tactical units for mutual support and local security.
- Avoiding possible enemy TRPs for enemy artillery and CAS.
- Locating the CP near an existing road network out of sight from possible enemy observation.

b. **Access.** CPs should be centered in the area of operations whenever possible. They should be near, but not next to, a high-speed avenue of approach with no more than one or two routes leading into the CP. These routes should provide cover, concealment, and access to other routes of communication. When possible, a helicopter landing zone should be nearby.

c. **Size.** The area selected must be large enough to accommodate all CP elements. This includes liaison teams from other units; communications support; and eating, sleeping, latrine, and maintenance areas. Sufficient area must be available for positioning security and vehicle dismount points and for parking.

d. **Shelter.** Dryness and light are vital when working with maps and producing orders and overlays. CPs should be sheltered from weather conditions and should have lights for night work, with proper light discipline exercised. Buildings are the best choice, but if none are available, CPs operate from their organic vehicles or tents.

e. **Operational Security.** The following paragraphs outline OPSEC considerations for positioning CPs.

(1) There should be no signs advertising CP locations. Disperse CP vehicles, and thoroughly camouflage all vehicles and equipment. Maintain noise and light discipline.

(2) A security force is required, and it must have communications with the CPs. Establish security force positions as in any defensive position, with a 360-degree perimeter and located far enough out to prevent enemy fires on the CPs. The security force should have antitank weapons to protect CPs from enemy armor. Establish a reserve reaction force and rehearse the execution of the perimeter defense.

(3) Battalion task forces normally rely on off-duty personnel for CP security. The command group may assist in securing a CP if collocated. Units may rarely be able to employ combat elements to help secure a CP.

(4) In general, positioning C3 assets off major enemy mounted avenues of approach reduces the enemy threat. Units should position CPs so the enemy bypasses them.

(5) An OP should secure any remote antennas located outside the perimeter.

(6) All subordinate units and elements of the CP must receive near and far recognition signals. The CP uses these signals, challenges, and passwords to control access into its perimeter.

(7) In case of artillery or air attack, a designated rally point and an alternate CP should be at least 500 to 1,000 meters away.

#### **11-6. DISPLACEMENT**

CPs may displace as a whole or, more often, by echelon. Displacement as a whole is normally reserved for short movements, with communications maintained by alternate means and minimal risk of degrading CP operations.

a. A portion of the CP, called a jump CP, moves to the new location, sets up operations, and takes over operational control of the battle from the main CP. The remaining portion of the CP then moves to rejoin the jump CP. The jump CP consists of the necessary vehicles, personnel, and equipment to assume CP operations while the remainder moves. At battalion task force level, the jump CP normally comes from within the main CP.

b. The XO or S3 selects a general location for the jump CP site. The jump CP can be accompanied by a quartering party, which may consist of a security element and personnel and equipment for quartering the remainder of the CP. The signal officer, who is usually part of the quartering party, ensures communications on all nets are possible from the new site. When the jump CP becomes operational, it also becomes the net control station for the unit. The remainder of the CP then moves to rejoin the jump CP.

c. Another technique of displacement is to hand off control to the command group and move the main CP as a whole. The command group can also split, with the commander moving with the main effort and the S3 moving with the supporting effort.

### **Section II. COMMAND POST OPERATIONS**

Each CP must be organized to permit continuous operations and the rapid execution of the command and control process.

#### **11-7. STANDING OPERATING PROCEDURES**

SOPs for each CP should be established, known to all, and rehearsed. These SOPs should include--

- The organization and setup of each CP.
- Plans for teardown and displacement of the CP.
- Eating and sleeping plans during CP operations.
- CP shift manning and operation guidelines.
- Physical security plans for the CP.
- Priorities of work during CP operations.
- Loading plans and checklists.
- Orders production.
- Techniques for monitoring enemy and friendly situations.
- Posting of CP map boards.
- Maintenance of CP journals and logs.

It will be many years before the majority of the army is digitally equipped and even then there will be elements operating within a joint or coalition environment that will not have

digital equipment. The staff must recognize that integrating an analog unit into the BN or TF requires the retention of most of the analog control techniques. In essence, two control systems must be in operation, with particular attention paid to keeping the analog unit(s) apprised of all the relevant information that is flowing digitally. (See Section IV, Communications Systems, for additional information.) The BN or TF SOP should include--

- Production and distribution of hard copy orders and graphics.
- Increased graphic control measures. Digital units tend to use less graphic control measures due to increased situational understanding.
- Receiving standardized reports over FM-voice or mobile subscriber equipment (MSE) communications.
- Equipping LNO teams with digital systems to give analog units limited connectivity.

### **11-8. COMMUNICATIONS**

Command posts monitor communications nets, receive reports, and process information to satisfy commander information needs or CCIR. This information is maintained on maps, charts, and logs. Each staff section maintains daily journals to log messages and radio traffic.

### **11-9. MAPS**

CPs maintain information as easily understood map graphics and charts. Status charts can be combined with situation maps to give commanders friendly and enemy situation snapshots for the planning process. This information must be updated continuously.

a. For simplicity, all map boards should be the same size and scale, and overlay mounting holes should be standard on all map boards. This allows easy transfer of overlays from one board to another.

b. The following procedures for posting friendly and enemy information on the map will aid commanders and staff officers in following the flow of battle.

(1) All graphics should be posted on an overlay. Friendly and enemy unit symbols should be displayed on clear acetate placed on the operations overlay. These symbols can be marked with regular stick cellophane tape, push pins, or with marking pen.

(2) The exact unit location is indicated by the lower left hand corner of the symbol.

(3) Units normally keep track of subordinate units two levels down. This may be difficult during the conduct of combat operations. It may be necessary to track locations of immediate subordinate units instead.

### **11-10. THE BATTLE CAPTAIN**

The focus of the TOC staff is on collecting the critical information the commander needs to fight the battle. Information flow is a constant problem in most TOCs, especially since everyone in the TOC must maintain a common operating picture. The battle captain's role is to plan, coordinate, supervise, and maintain communication flow throughout the TOC to ensure the successful accomplishment of all assigned missions. The TOC battle captain assists the commander, XO, and S3 by being the focal point in the TOC for communications, coordination, and information management. The battle captain is also the TOC OIC in the absence of the commander, XO, and S3.

a. The battle captain has the overall responsibility for the smooth functioning of the TOC facility and its staff elements. This range of responsibility includes--

- Maintaining continuous operations of the TOC while static and mobile.
- Battle-tracking the current situation.
- Ensuring communications are maintained with and between all stations and that all messages and reports are routed and logged per SOP.
- Assisting the XO with coordination of TOC staff functions to ensure a smooth and continuous information flow between the staff sections of the TOC.
- Processing essential data from the incoming flow of information to ensure all tactical and logistical information is gathered and provided to the TOC staff, S3, and XO on a regular basis.
- Providing security for the TOC, including its physical security and maintenance of noise and light discipline.
- Ensuring mobility of the TOC, including configuration, equipment, and training to facilitate rapid movement.
- Conducting TOC battle drills and enforcing TOC SOP.

b. The battle captain ensures that all staff elements in the TOC understand their actions in accordance with SOP and provides coordination for message flow, staff briefings, updates to TOC charts, and other coordinated staff actions. As a focal point in the TOC, the battle captain processes essential information from incoming data, assesses it, ensures dissemination, and makes recommendations to the commander, XO, and S3.

c. Information management in the TOC can include processing journals, message forms, reports, FRAGOs, and requests for information. The battle captain ensures the consistency, accuracy, and timeliness of information leaving the TOC, including preparing and dispatching FRAGOs and warning orders. In addition, he monitors and enforces the updating of charts and status boards necessary for battle management and ensures this posted information is timely, accurate, and accessible.

d. To function effectively, the battle captain must have a working knowledge of all elements in the TOC, understand unit SOP, and ensure the TOC staff uses them. He must know the current plan and task organization of the unit and understand the commander's intent. In addition, the battle captain must understand the limits of his decision-making and action authority.

e. The battle captain must be integrated into the decision-making process and know why certain key decisions were made. He must know the technical aspects of the battle plan and understand the time-space relationship to execute any specific support task. He must understand and enforce the battle rhythm--the standard events or actions that happen during a normal 24-hour period--and ensure the TOC staff is effective throughout the period. Battle captains use their judgment to adjust TOC activities and events to accomplish the TOC mission across different shifts, varying tactical circumstances, and changes in TOC location.

### **Section III. COMMUNICATION**

Communication is the means through which C2 is exercised. Soldiers throughout the organization must know the chain of command and succession of command. There must be open lines of communications up, down, and laterally. The commander should--

- Provide for redundancy in communications means by having backup at key locations.
- Make sure subordinates know what to do during interruptions in communications. Ensure SOP specifies immediate actions in case of jamming, including prearranged frequencies to switch to and code words.
- Avoid overloading the communications systems. Use them only when necessary. Practice disciplined communications procedures by eliminating nonessential conversations.

### 11-11. RESPONSIBILITIES

The order of responsibilities for communications is--

- Senior to subordinate.
- Supporting to supported.
- Reinforcing to reinforced.
- Passing to passed (for forward passage of lines).
- Passed to passing (for rearward passage of lines).
- Left to right.
- Rearward to forward.

All units take immediate action to restore lost communications. These responsibilities apply to establishing liaison between headquarters.

### 11-12. MEANS OF COMMUNICATION

As the Army enters the 21st century, digital communications upgrades will change the nature of operations at the battalion task force level. The information battlefield will see rapid dissemination of products up and down the chain of command and to adjacent units. The Army will share a common picture of the battlespace regardless of task organization. Emerging doctrine has redefined the Army tactical command and control system (ATCCS) as the integration of six functional area control systems (Figure 11-1, page 11-10) that provide situational information and decision support to the operating systems at echelons corps and below (ECB). Other means include couriers, sound and visual signals, telephones, and radios.

a. **Wire.** Wire is normally used for internal communications in the CP area, assembly areas, and defensive positions. Wire takes more time to plan, install, and recover, but provides reliable communication if time and the tactical situation permit its installation.

b. **Courier.** Couriers are used between C2 facilities and between higher and lower headquarters. Couriers are slower and more vulnerable than other means of communications but can be used when other means cannot be used. When authorized, motorcycle messengers can be used between the CP, trains, higher headquarters, and company teams. Messengers should be instructed on destruction procedures to prevent enemy capture of messages.

c. **Sound and Visual.** Sound and visual signals may be included in signal operating instructions (SOI) extracts or unit SOPs. Sound signals include metal-on-metal, vehicle horns, whistles, and bells. Visual signals include lights, flags, arm-and-hand signals, and pyrotechnics.



d. **Telephone Lines.** Commercial telephone lines can be used with permission of higher headquarters. If used, it should be assumed the enemy can monitor all calls made using commercial telephone lines.

e. **Radio.** Radio should not be the primary means of communication until after the unit makes contact.

f. **Army Tactical Command and Control System.** The principal ATCCS automation components of the ABCS are--

- MCS.
- AFATDS.
- FAADC31.
- ASAS.
- CSSCS.

g. **Force XXI Battle Command Brigade and Below.** FBCB2 is common to all aspects of the digitized battlefield; selected individuals in all platoons and company teams have one. It is in most C2 platforms and TOCs.

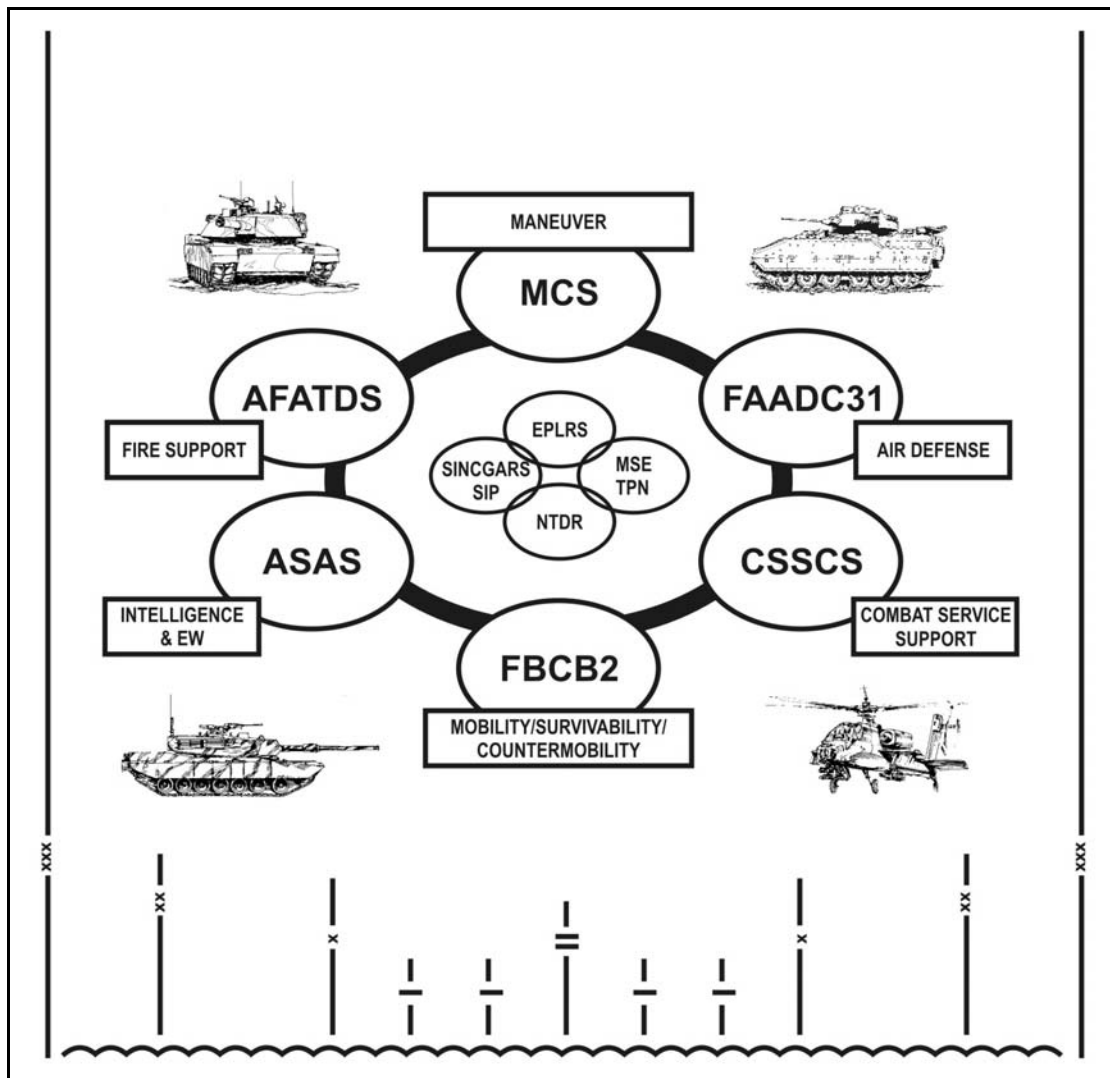


Figure 11-1. ATCCS.

### 11-13. COMMUNICATIONS SECURITY

The commander must understand the capabilities, limitations, and vulnerabilities of the CP communications systems and ensure the employment of effective communications control and security as an essential function of command post operations.

a. **Radio Transmissions.** Radio transmissions should be brief to reduce the EW signature. Using secure operational and numerical codes reduces the chance of enemy detection. Use low-power transmissions and terrain to mask signals from enemy direction-finding equipment. Use couriers or wire for lengthy messages. Units must practice using SOI, SOP, and operational terms.

b. **Physical Security.** Physical security protects cryptographic systems and classified documents from capture or loss. Before vacating an area, inspect it for any materials that could provide friendly information to the enemy. Patrol wire lines to prevent enemy tapping. When SOI codes or cryptographic equipment is lost or captured, report the facts promptly to the next higher command. The unit SOP must contain instructions for destruction of equipment and classified documents to prevent their capture or use by the enemy.

## Section IV. COMMUNICATIONS SYSTEMS

Communications is the means by which the commander projects his command and control across the width and depth of the battlefield. The Army battle command system encompasses all Army communications and consists of the following subordinate systems: Army global command and control system (AGCCS) at the operational or theater level and the Army tactical command and control system (ATCCS) at ECB. Communications currently available to the TF fall under one of the subsets of the ATCCS:

- Combat net radio (CNR).
- Army common user system (ACUS).
- Army data distribution system (ADDS).

### 11-14. COMBAT NET RADIO

The primary means of communication for the maneuver battalion task force is CNR. This family of push-to-talk radios includes the single-channel ground and airborne radio system (SINCGARS), improved high frequency radio (IHFR), and single-channel tactical satellite (TACSAT) radios.

a. **SINCGARS.** SINCGARS is the primary means of communications available to the TF. Although primarily a voice transmitter, SINCGARS can also be used to pass limited data transmissions. The planning range for this system is a maximum of ten kilometers dismounted and 35 kilometers mounted. The range can be extended through use of retransmission equipment or antennas such as the OE-254. SINCGARS, through CNR, can provide access into the ACUS via the KY-90 combat net radio interface (CNRI). The KY-90 is installed on the battlefield by the signal battalion. The SINCGARS radio nets typically installed by a battalion task force are command and control, intelligence, and administrative/logistical. The TF also enters and monitors nets established by its higher headquarters. When establishing SINCGARS nets for CP operations, remoting the antennas limits the enemy's ability to direction-find the CP location.

b. **Improved High Frequency Radio.** Using IHFR provides a versatile capability for short- and long-range communications and provides longer range than SINCGARS. High frequency (HF) is the only tactical communications asset that may achieve long-range communications independent of terrestrial or satellite relays. HF is also useful where line of sight (LOS) cannot be achieved. HF communications may be either voice or secure data, but the distribution of this equipment is limited to one or two sets per TF. Radio remains the most detectable means of electronic communications and is subject to both intentional and unintentional electronic interference.

c. **TACSAT.** The use of satellite communications gives the commander the greatest range. The TACSAT radio transmits in the UHF/VHF range, requiring the antenna to have LOS with the satellite. Satellite access time must be requested in advance of use.

### 11-15. ARMY COMMON USER SYSTEM

Mobile subscriber equipment provides the ACUS at ECB. Signal battalions install the backbone node centers (NCs) while small extension nodes (SENs) and radio access units (RAUs) provide access for the maneuver unit.

a. **Mobile Subscriber Radio Telephone.** The mobile subscriber radio telephone (MSRT) is the primary MSE equipment available to the TF. It consists of a VHF radio and a digital secure voice telephone (DSVT). The MSRT automatically selects random channels for each call and chooses the lowest effective radio frequency transmit level. The MSRT can be installed in a vehicular configuration, remote from the vehicle, or in a stand-alone mode when used with an appropriate power supply. The MSRT must be within 15 kilometers of a RAU site to communicate. Distribution in a TF is usually limited to two or three MSRTs.

b. **Digital Voice Nonsecure Telephone.** The digital voice nonsecure telephone (DVNT) is a four-wire nonsecure telephone terminal that requires collocation with a SEN to connect to the MSE network. The SEN provides connection to the tactical packet network (TPN) for the TF computers. Using the TPN allows the TF to connect commercial computers or Army systems (warlord or maneuver control system) to the MSE network. Typically, TF operations do not include task organization of a SEN for TF use. The FTCP located in the BSA is usually the first SEN access available to a TF.

### 11-16. ARMY DATA DISTRIBUTION SYSTEM

At ECB, the enhanced position location reporting system provides a network by which commanders can pass digital traffic.

### 11-17. THE DIGITAL BATTLEFIELD

The information battlefield will see rapid dissemination of products up and down the chain of command and to adjacent units. The Army will share a common picture of the battlespace regardless of task organization.

- a. The principal ATCCS automation components of the ABCS are--
- MCS.
  - AFATDS.
  - FAADC3I.
  - ASAS.
  - CSSCS.

- FBCB2.
- b. The principal ATCCS communication components of the ABCS are--
  - EPLRS.
  - Near-term digital radio (NTDR).
  - CNR SINCGARS system improvement plan (SIP).
  - MSE TPN.

### **11-18. TACTICAL INTERNET**

The TI is a collection of interconnected tactical radios and computer hardware and software providing seamless situational information and C2 data exchange between maneuver, CSS, and C2 platforms. The TI's primary function is to provide a more responsive information exchange capability to support battle command at brigade and below.

a. The TI consists of FBCB2 computers, the EPLRS very high-speed integrated circuits (VHSIC), the SINCGARS SIP, and other supporting communications equipment. It is an automated, router-based communications network using commercial Internet standard protocols to move data vertically and horizontally through the brigade area and to higher-level echelons using the MSE TPN. Automated network management tools in the maneuver battalion task force provide TI planning, monitoring, and reconfiguring capabilities.

b. The TI is divided into sub-areas: autonomous systems (ASs) and routing areas (RAs). Typically, a battalion task force represents one AS. An AS is a collection of networks, under a common administration, that shares a common routing strategy. An AS can consist of one or many networks, and each network may or may not have an internal structure. An RA is a network in an AS. RAs and the AS to which they belong share the same routing strategy.

### **11-19. FORCE XXI BATTLE COMMAND BRIGADE AND BELOW**

The FBCB2 hardware is a mix of commercial, ruggedized, and militarized computers installed in vehicles at brigade and below. When available, the FBCB2 can be connected to the precision lightweight GPS receiver (PLGR) and other embedded platform interfaces, such as the BCIS. FBCB2 is common to all aspects of the digitized battlefield and platforms found in platoons and companies. It is in most C2 platforms and TOCs.

a. FBCB2 uses the variable message format (VMF) to send and receive messages horizontally and vertically on the battlefield, irrespective of task organization. VMF improves current configurations in which the BOS automation systems do not communicate to each other. This provides communication and processing capabilities to the Warfighter, which yields significant advantages in two key areas.

(1) ***Situational Information.*** Situational information is a state of understanding gained from knowledge based on accurate and real-time information of friendly, enemy, neutral, and noncombatant locations. It consists of a common, relevant picture of the battlefield scaled to specific levels of interest and needs.

(2) ***Command and Control.*** C2 is direction by a commander over assigned forces in accomplishing a mission. A commander employs C2 functions as he plans, directs, and controls forces and operations to accomplish a mission.

b. FBCB2 provides each echelon with battlefield situational information two echelons up and down and one adjacent unit left and right. FBCB2 significantly improves the effectiveness of the force by providing up-to-date combat situation information, based on echelon and location, to include--

- Friendly and enemy positions.
- Air and ground unit positions.
- Maps, terrain, and elevation.

FBCB2 also provides rapid generation and dissemination of messages and acknowledgments to include--

- Orders and requests.
- Fires and alerts.
- Reports.
- Rapid generation and dissemination of overlays on the situation picture.
- Semiautomatic exchange of selected mission-critical data between the FBCB2 and the ABCS component systems.

c. For each task reorganization, FBCB2 hosts affected by the task reorganization must receive new initialization data. Transfer of the modified initialization data occurs through signal channels to the ultimate users.

#### **11-20. ENHANCED POSITION LOCATION REPORTING SYSTEM WITH VERY HIGH SPEED INTEGRATED CIRCUITS**

Battalion task force C2 platforms employ EPLRS VHSIC as their primary data communications link to company and platoon platforms. It serves as a position location, navigation, identification, and communications system. Its primary components are the NCS and the radio sets (RSs). The NCS is the centralized control element used for system initialization, monitoring, and control. The RSs are the radio receiver-transmitters provided to EPLRS VHSIC users. The TF uses EPLRS VHSIC to provide wide area network (WAN) connectivity down to platoon and up to brigade. The antenna used with the system is an omni-directional dipole. The planning range is three to ten kilometers between radios, depending on power output settings and terrain.

#### **11-21. RESPONSIBILITIES**

Key personnel include the battalion task force signal officer, unit signal support systems specialists, systems integration vehicle (SIV) operators, TOC LAN manager, and ABCS system administrator.

a. **Battalion Task Force S6 (C4 Operations Officer).** The battalion task force S6 manages the operations of communications systems received from the brigade communications systems to support its organization as well as the TF's own communications systems. He has OPCON of attached signal personnel. The battalion task force S6--

- Participates in the planning and operations process of the TF.
- Coordinates closely with the brigade signal officer (BCT S6) on planning and operating the TI as it relates to the TF.
- Understands the capabilities and operation of all communication and automation equipment in the TF.
- Advises the TF staff on communications matters.

- Receives and validates EPLRS VHSIC requirements and provides these to the brigade signal officer.
- Maintains the status of communications systems operating in the TF.
- Coordinates employment and operation of the SIV assigned for network management.
- Keeps the SIV team apprised of TF mission operations.
- Exercises supervisory responsibility for training and assigning the signal support system specialists military occupational specialty [MOS] 31U) in the TF.
- Develops a concise signal annex and communications/digital node architecture overlay to the TF OPLAN or OPORD.
- Tracks COMSEC distribution within the TF.
- Tracks all signal and digital nodes in the TF AO.

b. **Unit Signal Support Systems Specialists.** The unit signal support system specialists assigned to all units accomplish system maintenance and TI system initialization and re-initialization functions as required.

c. **SIV Operators.** The two information systems integrator-analysts and one single-channel radio operator are responsible for SIV operations. The information systems operator-analysts execute the network plan, initialize the network, and operate the network. The radio operator-maintainer establishes the site for the SIV and installs, operates, and maintains the radio systems (SINCGARS SIP, EPLRS VHSIC, and NTDR) in the systems integration vehicle.

d. **TOC LAN Manager.** The TF S3 is responsible for ensuring the TOC LAN (which supports all ABCS component systems) is properly integrated to provide synchronization of information needed for successful battle command execution.

e. **ABCS System Administrator.** The system administrator is responsible for the installation, operation, and maintenance of an ABCS computer host. Each ABCS component system (ASAS, AFATDS, CSSCS, FAADC3I, and MCS) assigns a "senior operator" to serve as system administrator.

## **Section V. DIGITAL COMMAND AND CONTROL SYSTEMS AND ARCHITECTURE**

This section provides basic information on the digital command and control systems and architecture that support brigade C2 operations.

### **11-22. ARMY BATTLE COMMAND SYSTEM COMPONENTS**

The ABCS consists of the ATCCS subcomponents, the FBCB2 system, and the tactical internet. The ATCCS components have traditionally been "stovepipe" systems in their development, with very limited interface capability to other digital systems. With version 6.0 software in late 1999, the systems began migration to a joint common database (JCDB) to improve interface capability and achieve functional commonality. The ATCCS components are the primary digital communication systems between command posts. FBCB2 is the primary digital system for communication and transmission of situational information data at task force level and below and for some brigade units (for example, the brigade reconnaissance troop). The ATCCS components discussed below

have embedded battle command software that allows interface with FBCB2. FBCB2 system hardware is not located in brigade CPs.

a. **Maneuver Control System.** The MCS is the hub of the ABCS component in each command post. It is the primary system for the creation and dissemination of orders, graphics, and operations-related reports. MCS automatically receives friendly forces positioning data generated by FBCB2- or embedded battle command- (EBC) equipped platforms of subordinate units resulting in the friendly picture. EBC is a software subcomponent of MCS. It is a derivative of FBCB2 software and allows MCS to exchange reports and graphics with FBCB2 systems.

(1) At task force level, MCS performs these primary functions:

- Receives orders and graphics from higher and adjacent units.
- Creates and disseminates orders and graphics to subordinate, higher, and adjacent units. Near-term ability to interface graphics and orders to FBCB2 and platform EBC is limited.
- Extracts information from other systems to display a picture of the battlefield that may include friendly and enemy situational information, terrain, friendly graphics, artillery range fans, ADA umbrellas, obstacles and contaminated areas, C2 nodes, and supply nodes.
- Sends and receives reports.

(2) Future system capabilities should allow for MCS to support course of action analysis and war gaming as well as digital rehearsals.

(3) Two MCS systems are located in the main CP. One is used primarily for generation and transmission of orders and messages; the other normally is set to display enemy and friendly situational information and friendly graphics to allow the staff to track the battle.

(4) There are limitations in the automatic generation of friendly situational information. Obviously, forces that are not equipped with FBCB2 or are not transmitting to the TI will not automatically appear in the situational information picture and must be manually input into MCS by the operations section. Operators may also manually input friendly icons via FBCB2.

b. **All-Source Analysis System.** ASAS supports intelligence operations, providing linkage to strategic and tactical intelligence sensors and sources. ASAS's primary functions include--

- Data access, database development, and correlation capabilities.
- Creation and dissemination of intelligence reports, templates, and annexes.
- Receipt of intelligence reports from a variety of sources (including FBCB2 and other digital systems) and display and management of the enemy picture.
- Collection management.
- Support of targeting functions.
- Linkage to JSTARS and UAVs (dependent on other systems and capabilities normally not available below brigade level).

The task force has a single ASAS system located in the S2 platform at the main CP. The S2 uses ASAS to receive intelligence reports from all sources and to create and manage the correlated enemy situational information picture, which the other ATCCS components in the CP can access. Additionally, the S2 routinely sends the ASAS picture he generates down to subordinate units via FBCB2. He also sends the situational

information picture to brigade, where it is integrated into the brigade-level enemy situational information picture by the brigade S2 section.

c. **Advanced Field Artillery Tactical Data System.** AFATDS provides automated capabilities to control fire support operations. Located in the FSE platform at the main CP and in the supporting artillery battalion CP, the system provides the ability to--

- Create and disseminate fire support orders, graphics, and control measures.
- Receive and process calls for fire from other digital systems and target acquisition radars.
- Manage mission allocation.
- Monitor firing unit status and locations.
- Transmit and receive reports and free-text messages.
- Display the enemy and friendly situational information pictures from MCS and ASAS.
- Provide integrated fires and intelligence and electronic warfare (IEW) management in conjunction with ASAS.

d. **Forward Area Air Defense Command, Control, Computers, and Intelligence System.** FAADC3I is the collection of computer and communication systems used to control air defense elements and create the air battle picture. It serves to integrate sensors (airborne warning and control system [AWACS], Patriot, Sentinel) with SHORAD weapons systems. The long-range air picture is created from information received from AWACS aircraft transmitted on joint tactical information distribution system (JTIDS) radios, and from the division's Sentinel air acquisition radars transmitted through the ground-based sensor (GBS). Air track data is sent via EPLRS and SINCGARS radios to individual firing elements (Linebacker, Avenger, and Stinger teams). The total FAADC3I system provides real-time enemy air engagement operations, airspace situational information, and air threat early warning. The air defense element in the task force CP is equipped with an amplitude modulated (AM) radio to monitor the division air defense early warning net and a handheld terminal unit that provides a digital link to the FAADC3I network. FM voice remains the primary means for transmitting initial air threat warnings to the task force as a whole for the near-term. FBCB2 is the secondary method and is capable of displaying both visual and audible alerts to crews.

e. **Combat Service Support Control System.** CSSCS provides logistics status and information in support of CSS planning and operations. The system receives subordinate unit logistical reports from FBCB2 and other CSSCS terminals, and it transmits reports and requirements to echelons-above-brigade support elements. The S1 and S4 sections in the CTCP have a CSSCS terminal with FBCB2. It uses this terminal to receive digital logistical and situation reports from units within the task force and to input data into the CSSCS network to conduct personnel transactions and to request, coordinate, and receive supplies.

f. **FBCB2.** FBCB2 is the foundation system for ABCS. Mounted on most of the vehicles in the task force, each system is linked to a PLGR and a SINCGARS or EPLRS radio. Each FBCB2 generates and transmits its own position location. Collectively, the FBCB2 systems generate the friendly situational information picture. Operators use FBCB2 to generate enemy spot reports, which comprise most of the enemy picture at the tactical level. The messaging, reporting, and orders and graphics capabilities of the system support battle command for each battlefield functional area. FBCB2 receives data



---

across the tactical internet via the internet controller (INC). The INC is a tactical router built into the SINCGARS radio system. The EPLRS data radio and the SINCGARS radio transmit and receive digital information between vehicles.

### **11-23. DIGITAL COMMAND AND CONTROL TECHNIQUES**

This paragraph discusses considerations and techniques for digital command and control procedures and for integrating analog and digital units. The potential of these systems to contribute to battlefield lethality, tempo, and ability to dominate is enormous. Digital command and control systems bring a dramatic increase in the level of situational information units may achieve. They can significantly speed the process of creating and disseminating orders, allow for extensive databasing of information, and increase the speed and fidelity of coordination and synchronization of battlefield activities. At the same time, achieving the potential of these systems requires extensive training, a high level of technical proficiency by both operators and supervisors, and the disciplined use of detailed SOPs. Communications planning and execution to support the digital systems is significantly more demanding and arduous than is required for units primarily relying on FM and MSE communications.

a. **FM or Digital.** Whether to use FM or digital means for communication is a function of the situation and SOPs. Even though both systems are critical for effective C2 at the task force level, FM remains the primary method for control at task force level and below during operations, with additional support from the situational information display provided by FBCB2 or EBC. Some general considerations can help guide the understanding of when to use which mechanism at what time.

(1) FM is the primary method of communications between task force and brigade and when elements are in contact throughout the task force. Prior to and following an engagement, the staff and commanders use digital systems for disseminating orders and graphics and conducting routine reporting. During operations, however, the task force staff uses a combination of systems to report and coordinate with higher and adjacent units.

(2) Staffs at higher echelons, particularly division and brigade levels, must remain sensitive to the difficulty and danger of using digital systems when moving or in contact. They should not expect digital reports under those conditions. Digital reporting builds the COP (particularly the posting of enemy icons) and failure to render such reports results in an incomplete COP. Additionally, the units must build the COP as the action occurs in order to provide the commander with a COP that contains relevant information that leverages his decision making. Other general guidelines include--

- Initial contact at any echelon within the task force should be reported on FM voice; digital enemy spot reports should follow as soon as possible to generate enemy situational information.
- Elements moving about the battlefield (not in command posts) use FM voice unless they can stop and generate a digital message or report.
- Emergency logistical requests, especially casualty evacuation requests, should be initiated on FM voice with a follow-up digital report if possible.
- Combat elements moving or in contact should transmit enemy spot reports on FM voice; their higher headquarters should convert FM reports into digital

spot reports to generate situational information. At team level, the XO and the first sergeant convert the reports.

- Calls for fire on targets of opportunity should be sent on FM voice; team FISTS submit digitally to AFATDS.
- When equipped with the far target locator (FTL), vehicle crews should engage the target with the FTL and select the call for fire message button on the spot report (SPOTREP) enabling a digital call for fire.
- Planned calls for fire from FISTS in the initial part of an engagement should be sent digitally.
- Routine logistical reports and requests should be sent digitally.
- Routine reports from subordinates to task force prior to and following combat should be sent digitally.
- Orders, plans, and graphics should be sent digitally, accompanied by an FM voice call to alert recipients that they have critical information being sent to them. Additionally, the transmitting element should request a verbal acknowledgement of both receipt and understanding of the transmitted information by an appropriate soldier (usually not the computer operator).
- The transmission of a TF order via FBCB2 is time consuming and difficult to read and manipulate. FBCB2 best handles short FRAGOs and WARNOS.
- Obstacle and NBC-1 reports should be sent initially by voice followed by digital reports to generate a geo-referenced situational information message portraying the obstacle or contaminated area across the network.

b. **Friendly Situational Information.** The creation of friendly situational information is extensively automated, requiring minimal manipulation by command posts or platform operators. Each platform creates and transmits its own position location and receives the friendly locations (displayed as icons) of all the friendly elements in that platform's wide area network. This does not necessarily mean that all friendly units in the general vicinity of that platform are displayed, however, since some elements may not be in that platform's network. For example, a combat vehicle in a task force will probably not have situational information on a corps artillery unit operating nearby since the two are in different networks. The situational information generated from individual FBCB2- or EBC-equipped platforms is transmitted to command posts through the TOC server to MCS. The other ATCCS components can access the friendly situational information picture through MCS.

(1) Commanders must recognize limitations in the creation of friendly situational information that results from vehicles or units that are not equipped with FBCB2 or EBC. The following are two aspects to consider.

(a) Not all units will be equipped for years to come, particularly in the reserve component. With over 60 percent of the corps logistical units and supporting artillery in the Army Reserve or National Guard, it is inevitable that analog units will enter the brigade and task force area of operations.

(b) Most dismounted soldiers will not be equipped with a digital device that transmits situational information. A system for dismounted soldiers has been under development for some time, but may not be fielded by 2005. Distribution of the system will probably not be below squad leader level.

(2) The following are ways to overcome these shortfalls.

(a) A digitally equipped element tracks the location of specified dismounts and manually generates and maintains an associated friendly icon. As an example, the mechanized team XO can generate an icon for dismounted squads.

(b) The task force main CP tracks analog units operating with the task force and generates associated friendly icons.

(c) A digitally equipped platform acts as a liaison or escort for analog units moving or operating in the task force area. Task force and higher elements must be informed of the association of the LNO icon with the analog unit.

(d) Do not use friendly situational information to clear fires since not all elements will be visible. Friendly situational information can be used to deny fires and can aid in the clearance process, but it cannot be the sole source for clearance of fires. This holds true for all ABCS systems.

c. **Enemy Situational Information.** The hardest and most critical aspect of creating the situational information picture is creating the picture of the enemy. The enemy situational information picture at brigade and task force levels is the result of multiple inputs--FM spot reports, UAV and JSTAR reports, reports from FBCB2- and EBC-equipped platforms in subordinate units, electronic or signal intelligence feeds, and inputs from the S2 section. Enemy situational information generation is a complex process that is partially automated but requires a great deal of work and attention to detail to get right.

(1) Generation of the enemy situational information picture occurs at all echelons. At task force level and below, the primary mechanism for generating situational information is FBCB2 (or EBC). When an observer acquires an enemy element, he creates and transmits a spot report, which automatically generates an enemy icon that appears network-wide. Only those in the address group to whom the report was sent receive the text of the report, but all platforms in the network can see the icon. As the enemy moves or its strength changes, the observer must update this icon. If the observer must move, he ideally passes responsibility for the icon to another observer. If multiple observers see the same enemy element and create multiple reports, the task force or brigade S2 (or some other element that has the capability) must eliminate the redundant icons.

(2) FBCB2 spot reports must include the higher headquarters S2 in the address group for the data to be routed through the TOC server into ASAS to feed the larger intelligence picture. FM reports received at a command post can be manually input into the ASAS database by the S2 section. FBCB2 and FM voice reports are the primary source of enemy situational information for fighting the close and rear battles.

(3) At brigade, the S2 section and the supporting ACT receive ASAS intelligence feeds from higher and adjacent units along with feeds from JSTARS, UAVs, and the common ground station (CGS). They enter enemy information from these sources into the ASAS database and send this information via ASAS to the task force S2s. These feeds, along with FM voice and FBCB2 reports, are the primary source of enemy situational information for executing the brigade deep fight and providing TFs a picture of what is coming into their areas.

(4) Fusion of all the intelligence feeds is normally done at brigade and division levels. The brigade S2 routinely (every 30 minutes to every hour) sends the updated enemy situational information picture to subordinate units down to platform level. Since the fused ASAS database is focused on the deeper areas of the battlefield and its timeliness may vary, subordinate task force elements and the reconnaissance troop normally use

only the FBCB2-generated intelligence picture. Company teams should stay focused entirely on the FBCB2-generated enemy situational information. Task force leaders and staffs refer occasionally to the ASAS-generated intelligence picture to keep track of enemy forces that will be encountered in the near future but that are not yet part of the task force close fight.

(5) As systems develop further in the future, the generation of enemy situational information will be increasingly automated. However, the success of the intelligence effort depends primarily on the ability of staffs to analyze enemy activities effectively, to develop and continuously refine effective IPB, and to create and execute effective collection management plans. Automation and displays contribute enormously to the ability to disseminate information and display it in a manner that aids comprehension, but information generation must be rapid for it to be useful. Information must also be accompanied by analysis: pictures alone cannot convey all that is required, nor will they be interpreted the same by all viewers. S2s must be particularly careful about spending too much time operating an ASAS terminal while neglecting the analysis of activities for the brigade and subordinate commanders and staffs.

(6) The enemy situational information picture usually is incomplete and less current than friendly situational information. The timeliness and accuracy of the enemy picture always must be scrutinized. Units must use the picture to focus observers and orient the fire support process but should not use it as the sole source for generating indirect fire support target location data--it usually will not be timely enough.

d. **Graphics and Orders.** All ATCCS components effectively support the creation and transmission of doctrinal field orders. The brigade staff sections normally develop their portions of orders and send them to the S3 who plans MCS, where they are merged into a single document and transmitted to subordinate, higher, and adjacent units. In creating orders, remember that the tactical internet does not possess high transmission rates like civilian e-mail. Orders and graphics must be concise to reduce transmission times. Orders transmitted directly to FBCB2-equipped systems (as all subordinate leaders in the task force have) must meet the size constraints of the order formats in FBCB2 and EBC. Graphics and overlays should be constructed with the same considerations for clarity and size. Situational information reduces the need for control measures to some degree, but the staff must always consider the integration of analog units and that situational information may not always be available to all elements.

(1) **Graphics.** When creating graphics on an ATCCS component, remember that the primary users will be FBCB2- or EBC-equipped. The graphics must interface and transmit. The interface and commonality of graphics will continue to evolve technologically and will require further software corrections. The following guidelines apply.

(a) Create control measures relative to readily identifiable terrain, particularly if analog units are part of the task organization.

(b) Boundaries are important, but digital units tend to disregard them initially until multiple units have to operate in near proximity or until it becomes necessary to coordinate fires or movement of other units.

(c) Intent graphics that lack the specificity of detailed control measures are an excellent tool for use with warning and fragmentary orders and when doing parallel planning. Follow them with appropriately detailed graphics as required.

(d) Use standardized colors to differentiate units. This should be articulated in the brigade SOP and established at brigade level. For example, brigade graphics may be in black, armor TF A in purple, armor TF B in magenta, and mechanized infantry TF in brown. This adds considerable clarity for the viewer. Subordinate team colors should be specified.

(e) Use traditional doctrinal colors for other graphics (green for obstacles, yellow for contaminated areas, and so on), but develop an SOP that uses the color capabilities of the systems to identify both templated actions or activities (such as proposed obstacles and templated enemy actions or positions) and executed or actual activities (emplaced obstacles and observed enemy).

(2) **Overlays.** When creating overlays, use multiple smaller overlays instead of one large overlay to speed transmission times. System operators can open the overlays they need, displaying them simultaneously. This technique also helps operators in reducing screen clutter.

(a) The S3 should create the initial graphic control measures (boundaries, objectives, and phase lines) on a single overlay and distribute it to the staff. This overlay should be labeled as the operations overlay with the appropriate order number.

(b) Staff elements should construct their appropriate graphic overlays using the operations overlay as a background but without duplicating the operations overlay. This avoids unnecessary duplication and increase in file size and maintains standardization and accuracy. Each staff section labels its overlay appropriately with the type of overlay and order number (for example, fire support, OPORD X-XX).

(c) Before overlays are transmitted to subordinate, higher, and adjacent units, the senior battle captain or the XO checks them for accuracy and labeling. Hard copy (traditional acetate) overlays are required for the CPs and any analog units.

(d) Personnel transmit graphics for on-order missions or branch options to the plan before the operation, as time permits. If time is short, they transmit graphics with warning orders.

(3) **Acetate and Maps.** The advent of digitization does not mean that acetate and maps have no use and will disappear, at least not in the near future. Maps still remain the best tool when maneuvering and fighting on the battlefield or for controlling and tracking operations over a large area. The combination of a map with digital situational information and terrain database is ideal; both are required and extensively used.

## 11-24. STANDING OPERATING PROCEDURE CONSIDERATIONS

This paragraph contains information regarding digital operations that is relevant for the brigade and task force tactical SOPs. Most of the digital operating procedures must be established at brigade level to achieve standardization and effective C2. As units have different mission requirements and technical changes occur, they should experiment with these guidelines.

a. **Filter Settings.** For there to be a common picture, all FBCB2 and EBC platforms must have the same situational information filter settings. This is particularly important for the enemy situational information picture so that as icons go stale, they purge at the same time on all platforms. Standard filter settings based upon the nature of the enemy's operation should be established in unit SOPs and be the same throughout the brigade. For enemy offensive operations, the filter setting times should be short; for enemy defensive

operations, the setting times should be longer, reflecting the more static nature of the enemy picture.

(1) Standard filter setting may need to be adjusted based on the terrain and the mission. In compartmented, difficult terrain, longer settings are more appropriate, perhaps 10 minutes for the attack. In wide-open, fast-paced operations in the desert, however, shorter settings in the 5-minute range may be more appropriate. Also, as the enemy transitions from offensive to defensive operations, the decision should be made at brigade level to change to the appropriate standard filter setting.

(2) The standardization of friendly filter settings is of equal importance in maintaining a common situational information picture throughout the force. FBCB2 provides three methods for updating individual vehicle locations: time, distance, and manually. When the system is fully operational, it automatically updates friendly icons using time, distance traveled, or both, based on the platform's friendly situational information filter settings. These settings should be standardized across the force based on both the mission and the function of the platform or vehicle, with shorter refresh rates for combat vehicles and vehicles that frequently move versus longer refresh rates for fairly static vehicles such as TOCs. Tailoring the frequency of these automatic updates also reduces the load on the tactical internet, freeing more capacity for other types of traffic.

(3) The friendly icon refresh rate may also change as the battle is executed. This is especially true in the transition from the offense to the defense or vice versa. The standardization of friendly situational filter settings is probably most effectively done at the brigade level using the brigade tactical SOP. There are no set rules for what these settings should be; they must be established based on the unit's experience in using FBCB2 and the capacity of the tactical internet. The capability to update a vehicle's position manually should be used only when a platform's system is not fully functional and has lost the ability to maintain its position within the system.

b. **Reporting.** It may not be advantageous to have all platforms on the battlefield send spot reports digitally. This can lead to multiple reports of the same enemy element and contribute to an already confused and indecipherable intelligence picture. Defining who within the brigade can initiate digital spot reports can help eliminate this problem. One technique is to limit the creation of enemy icons via digital spot reports to reconnaissance elements (brigade reconnaissance troop and task force scouts) and the company team leadership (commander, XO, or 1SG). Others report on FM to their higher headquarters, which creates and manages the icon. This also helps those who execute the direct fire fight by moving the digital reporting responsibility to someone who is somewhat removed from the fight. At company level, the XO, 1SG, or CP personnel become the primary digital reporters. These assignments cannot be completely restrictive. Unit SOPs and command guidance must allow for and encourage soldiers who observe the enemy and know they are the sole observer (because there is no corresponding enemy icon displayed in the situational information picture) to create a digital spot report. Brigade and task force SOPs should define the schedule for report submissions, the message group for the reports, and the medium (digital system or verbal) to be used.

c. **Updates.** Establish a routine schedule of system updates. For example, the S2 section should continuously update the ASAS database and should transmit the latest ASAS situational information picture to the network every 30 minutes during operations

if the task force commander, S3, or scouts need it. Also, staff sections should print critical displays on an established schedule. These printed snapshots of situational information can be used for continuity of battle tracking in the event of system failures and can contribute to AARs and unit historical records.

d. **Orders and Overlays.** SOPs should define the technical process for creating, collating, and transmitting orders and overlays, both analog and digital.

e. **Filing System Naming Convention.** For interoperability and clarity, brigade SOPs should define the naming convention and filing system for all reports, orders, and message traffic. This significantly reduces time and frustration associated with lost files or changes in system operators.

f. **Color Standards.** As discussed previously, SOPs should define colors used in graphics down to team level.

g. **Databases.** C2 systems will inevitably migrate to a web-based capability, allowing information to be databased and then accessed by users as needed or when they are able to retrieve it. Commanders should establish standard guidelines for setting FBCB2 default addresses in their units. For example, the S2 may transmit an intelligence summary to all subordinates and inevitably some will lose the file or not receive it. The S2 can simultaneously post that same summary to his “homepage” so users can access it as required. If this technique is used, there are a couple of key things to note:

- Posting a document to a homepage does not constitute communications. The right people must be alerted that the document is there and available.
- Keep documents concise and simple. Elaborate PowerPoint slide briefings will take days to transmit, collapsing the tactical Internet. Gaudy graphics and templates are a no-go.
- The amount of information databased and who has access must be carefully controlled, both to maintain security and to keep from overloading the tactical internet.

## 11-25. INTEGRATING DIGITAL AND ANALOG UNITS

It will be several years before the majority of the Army is digitally equipped. Even then, the brigade will operate with elements without digital equipment, especially in joint or coalition environments. National Guard and Army Reserve units, light forces, supporting corps artillery, and corps-level logistical units are the most likely types of analog units with which brigades and task forces will operate. Procedures for integrating digital and analog units are essential for the brigade.

- a. FM and MSE are the primary communications mediums with the analog unit.
- b. Hard copy orders and graphics are required.
- c. Graphical control measures require the level of detail necessary to support operations of a unit without situational information. In general, this requires more control measures tied to identifiable terrain.
- d. Digitally equipped LNO teams are critical.
- e. The task force staff must recognize that integrating an analog unit into a digital unit requires retention of most of the analog control techniques. In essence, two control systems must be in operation, with particular attention paid to keeping the analog unit apprised of all pertinent information that flows digitally.

---

## CHAPTER 12

# TACTICAL ENABLING OPERATIONS

*Tactical enabling operations are specialized missions that are planned and conducted to achieve or sustain a tactical advantage; they are executed as part of an offensive, defensive, stability, or support mission. The fluid nature of the modern battlefield increases the frequency with which the TF must plan and execute enabling operations such as passage of lines, relief operations, obstacle reduction, linkup operations, and high-value asset security. At the TF level, digital systems such as FBCB2 and ABCS facilitate the planning and execution process of these often complex and decentralized operations. This chapter establishes techniques and procedures unique to the TF that can be applied to these specialized missions.*

### Section I. RELIEF OPERATIONS

A relief is an operation in which one unit replaces another in combat. The incoming unit assumes responsibility for the mission and the assigned area of operation. A relief-in-place may be conducted at any point during offensive or defensive operations. Relief operations are normally executed during limited visibility to reduce the possibility of detection. FBCB2 enhances the planning and execution of relief operations while the BCIS aids in differentiating friendly from enemy as units conduct the linkup and passage of lines. This greatly reduces fratricide potential and expedites forward movement since the relieved force can monitor the progress of the linkup force and provide protective fires or adjust fire control measures predicated on the speed with which the linkup force is moving. To facilitate and ensure successful operations, the linkup and relieved force commanders and staffs exchange as much information as possible to prevent the inadvertent engagement of friendly forces by either direct or indirect fire systems during relief operations. Digitally equipped units can pass this information through an exchange of FBCB2 overlays that clearly define friendly positions, fire support control measures, obstacles, linkup points, and signals. Nondigitized units should exchange this information through liaison personnel and conventional acetate overlays. Collocation of CPs for both types of units is recommended.

#### 12-1. PLANNING CONSIDERATIONS

Upon receipt of the order to conduct the relief, the incoming TF commander and staff establish continuous liaison with the stationary unit through an exchange of liaison personnel or a digital exchange of information pertinent to the relief operations. Commanders and staffs emphasize communications, reconnaissance, and transfer of command. If possible, the incoming unit should collocate with the main CP to facilitate continuous information exchanges relative to the occupation plan, fire support plan, and intelligence updates that include past, present, and probable enemy courses of action. Although digitization allows coordination without physically locating together, face-to-face coordination reduces any potential misunderstandings related to relief preparation or the forthcoming operations. Before contact with the stationary unit, the relieving force digitally receives the maneuver graphics, fire plan, and current enemy situation by way of



FBCB2 or MCS overlays. Responsibility for the area is transferred as directed by the senior common commander, normally when the incoming unit has a majority of his fighting force in place and all communications systems (voice and digital) are operating. When planning the relief, the staff should consider the realities of risk management and fratricide avoidance (Appendix D) in determining the most appropriate method for executing the relief.

a. **Relieving Units One at a Time.** This method is the most deliberate and time-consuming. It involves sequentially relieving maneuver company teams one at a time. Separate routes to the rear of the relieved company teams' locations are planned for each maneuver company team and placed on the operations overlay. To avoid cluttering the FBCB2 display, only the routes of the relieving force are included on the operations overlay. Routes are labeled sequentially and correspond to the order in which the company team executes them during the relief. When the lead company team reaches its RP, its platoons move to the positions they are occupying. Crews exchange range card and fire support information, and the relieved unit then moves to the rear to its next location. When the lead company team is in position, the next company team moves along its designated route to relieve its counterpart, repeating the relief process. This process repeats until each company team has been relieved. If transfer of supplies from the relieved unit is directed, the S4 coordinates a transfer point to execute the exchange.

b. **Relieving Units at the Same Time.** This method is the fastest, but it risks revealing friendly unit intentions. To expedite the relief, the in-place TF prepares FBCB2 overlays to depict current friendly graphics, fire support measures, and the latest enemy situation update. They pass these overlays to the relieving force before the two forces make contact. Once the command groups collocate and exchange plans, relief occurs at the same time at each location. The units of the relieving and relieved TFs execute a move at the same time along different routes. Relieved units withdraw as soon as they are relieved and do not wait for other units of the TF to be relieved. The control measures at the TF level are identical to those used for a sequential relief (one unit at a time).

c. **Relieving Units by Occupying In-Depth and Adjacent Positions.** This technique requires sufficient terrain to accommodate positioning of two like-sized units at the same time. In this case, the relieving unit must locate where it can observe and provide protective direct and indirect fires for the relieved unit using the relieved units' fire plans. This procedure requires that relieving company team and TF commanders conduct a detailed physical reconnaissance of the BP with their counterpart from the in-place unit. They enter information gathered from the physical reconnaissance (for example, BPs, TRPs, and routes into and out of the area) on FBCB2 operations overlays and share them throughout the relieving unit during the planning and troop-leading procedures (TLP) process.

## **12-2. CONDUCTING THE RELIEF**

Execution of the relief follows one of the three previous techniques. During the relief, the command group and the staff in the main CP monitor the progress of the relief through FBCB2. To facilitate uninterrupted fires to support the relief, indirect fire assets should be the last units relieved regardless of the relief technique used. Throughout this process, the TF may have to observe radio-listening silence until control of the position passes to the commander of the relieving force. When the company teams are set and the relieved

unit withdraws from the BP, company team commanders send the S3 an FBCB2 SPOTREP indicating that the company team is defending.

### 12-3. COMMAND AND CONTROL

If either force gains direct fire contact with an enemy force, it immediately notifies the other unit and the higher headquarters by way of FM voice communications. It then follows this voice report up with an FBCB2-generated contact report or SPOTREP so that the precise location of the enemy force (enemy icon) is displayed on FBCB2. If responsibility for the sector has not passed, the relieving unit becomes OPCON to the relieved unit. The assets and staff of the relieved unit become OPCON to the relieving unit when the responsibility for the sector has passed to the relieving TF.

## Section II. SECURITY OPERATIONS

The purposes of security operations are to provide early and accurate warning of enemy operations, to provide the protected force with time and maneuver space to react to the enemy, and to develop the situation to allow the commander to employ the protected force effectively. Units may conduct these operations to the front, flanks, or rear of a larger force. Security operations provide reaction time, maneuver space, and protection to the main body. Security operations are characterized by aggressive reconnaissance aimed at reducing terrain and enemy unknowns, gaining and maintaining contact with the enemy to ensure continuous information, and providing early and accurate reporting of information to the protected force. Security operations forces orient in any direction from a stationary or moving force. Security operations are designed to deny the enemy intelligence information concerning the TF. Security operations contain both passive and active elements and normally include combat action to seek, destroy, or repel enemy reconnaissance units. The TF performs three primary types of security missions: screen, guard, and area security. The TF normally participates in covering force operations only as part of a larger element.

### 12-4. SCREEN

The primary task of a screening force is to provide early warning. It observes, identifies, and reports enemy actions. A screen provides the least amount of protection of any security mission. Generally, a screening force engages and destroys enemy reconnaissance elements within its capabilities but fights otherwise only in self-defense.

a. **Task Force Screen.** At the TF level, the scout platoon normally performs screen missions. When the terrain provides multiple enemy avenues of approach, the TF commander may attach the scout platoon to a company team to conduct a screen. The screening force generally establishes a series of OPs and conducts patrols to ensure adequate surveillance of the assigned sector.

b. **Company Team Screen.** A company team may be directed to conduct a screen in support of TF offensive and defensive operations. When given a forward screen mission, the company team moves as in a movement to contact.

c. **Planning a Screen.** When assigning a screen mission to a company team, the TF commander will designate the general trace of the screen and the time it must be established. The initial screen line should be forward of the general trace but remain

within range of supporting artillery and TF mortars. Screen lines are depicted as phase lines; passage graphics are included in the overlay.

(1) Designate the left and right limits of the screen as well as a phase line for the near boundary. This phase line can also become the on-order battle handover line.

(2) Confirm which unit has responsibility for the area between the screening force's rear boundary and the MBA. This should be the company team that occupies the sectors behind the screen.

(3) Designate general locations for OPs that enable observation of the avenues of approach into the sector.

(4) Select routes or sectors to facilitate rearward displacement.

(5) Augment the security force as needed to provide intelligence, engineer, air defense, signal, and combat service support.

d. **Intelligence Support.** The S2 designates which NAI the company team must observe and when. The S2 does not dictate the location of company team elements nor how the company team maintains surveillance of the NAI. If GSRs operate under TF control to support the security effort, the S2 positions these assets and integrates their locations and missions with the security action of the screening company team. Once the screen force commander positions his elements, he informs the S2 of their primary, alternate, and subsequent locations.

e. **Maneuver.** Generally, the best unit configuration for the screen mission is a mechanized infantry company team. The ability to place infantry rifle squads on the ground and conduct surveillance operations and active patrolling is an essential passive aspect of the screen mission. The tank platoon may be employed to destroy the enemy's reconnaissance vehicles during the counterreconnaissance fight.

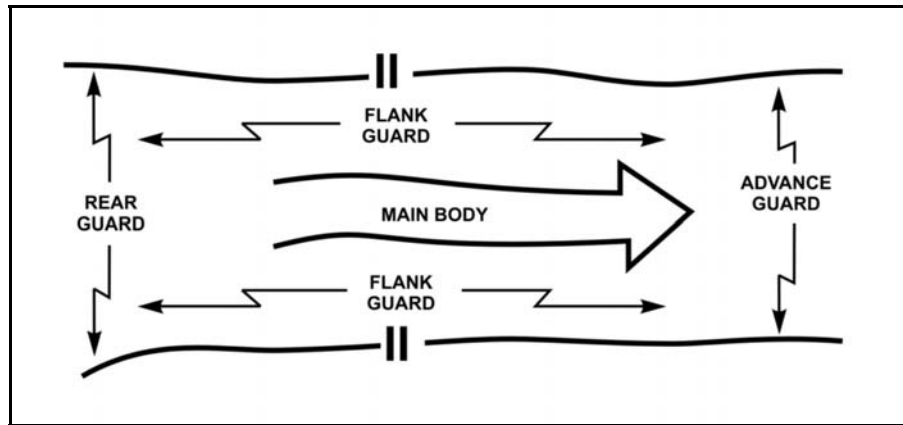
f. **Fire Support.** The FSO prepares for the screen mission as he would for a forward defense. He uses the enemy situation template as a guide to plan fires to interdict enemy maneuver elements. He plans protective fires for all screen force positions; this helps prevent screening force elements from becoming decisively engaged with the enemy. Accurate indirect fire is essential to the destruction of the enemy reconnaissance effort. The FSO conducts a time-distance analysis covering the enemy's probable rate of advance and the time of flight of artillery or mortars. If available, Striker teams from the BRT may be added to the screen force for use against enemy vehicles.

g. **Engineer Support.** Generally, the engineer effort is dedicated to the TF's main defensive area. If available, some engineer effort may be dedicated to the forward screen. This may include engineer squads or sections attached with the screen force to emplace obstacles or allocation of FASCAM to the screen force. The obstacle intent is to disrupt enemy reconnaissance elements forward of the main battle area. Typically, the disrupt obstacles that are emplaced are conventional point minefields, MOPMS, Hornet, or wire obstacles that are overwatched by observers and targeted by indirect fire assets.

h. **Logistics.** The logistics planner must plan for responsive and flexible support that may require the immediate resupply of ammunition and evacuation of casualties and equipment upon contact. Lateral supply routes to each battle position are identified during the planning process. Moreover, on-order control measures, LRPs, UMCPs, and AXPs are essential to the operation. Emergency resupply vehicles carrying ammunition, fuel, and other quickly expendable supplies are prepared to respond to sudden requisitions due to enemy contact.

## 12-5. GUARD

A guard mission is assigned to protect the force by observing the enemy, reporting pertinent information, and fighting to gain time. The guard force differs from a screen force in that it contains sufficient combat power to defeat, repel, or fix the lead elements of an enemy ground force to prevent it from engaging the main body with direct fires. The guard force normally deploys over a narrower front than a comparably sized screening force, allowing greater concentration of combat power. The guard force routinely engages enemy forces with both direct and indirect fires and operates in range of the main body's indirect fire weapons. The guard force commander must understand fully the degree of security his unit provides the larger unit. This understanding is critical because, as the battle progresses, the higher unit commander may require the degree of security to change (for example, from early warning to detailed and aggressive security for the main body). There are three types of guard operations conducted in support of a stationary or moving friendly force (Figure 12-1): rear, flank, and advance guard.



**Figure 12-1. Rear, flank, and advance guard operations.**

a. **Advance Guard.** The advance guard moves ahead of the main force to ensure its uninterrupted advance, to protect the main body against surprise, to facilitate its advance by removing obstacles and repairing roads and bridges, and to cover the deployment of the main body as it is committed to action. The advance guard is a task-organized, combined arms unit or detachment that precedes a column or formation.

(1) The advance guard is normally conducted as a movement to contact. Generally, a TF receives an advance guard mission when the brigade moves as part of the division main body in a movement to contact. In deploying an advance guard, the brigade ensures the TF has priority of fires from the DS artillery battalion. Unlike a movement to contact, however, the advance guard clears the axis of enemy elements, within its capability, to allow the unimpeded movement of the main body TFs. The advance guard develops the situation to hand over the enemy to the TF.

(2) Based on METT-TC, trail elements of the advance guard must ensure they maintain adequate distance forward of the main body's lead elements to ensure freedom of maneuver for the main body. These distances are reduced in close terrain and in low visibility conditions. The TF commander establishes phase lines to control the movement of the main body and the advance guard. Further, the TF commander must take into consideration the range of supporting indirect fires.

(3) The advance guard force attempts to destroy enemy forces through hasty attacks. It may be necessary for the TF to mass at certain locations, destroy the enemy, report, and continue with its mission. If enemy resistance is well prepared and cannot be destroyed, the TF reconnoiters to identify a bypass route for the main body, to report enemy size and location, and (when given permission) to fix and bypass the enemy. The follow on attacking forces are responsible for destroying the bypassed enemy. The main body commander may elect not to bypass the enemy but to conduct an attack. In this case, the advance guard keeps the enemy contained and prepares to pass main body elements through to eliminate the enemy.

b. **Rear Guard.** When a division conducting a movement to contact requires rear security, a TF may receive a rear guard mission. The rear guard protects the rear of the main body and all CS and CSS elements in the main body. It may accomplish this by conducting an attack, a defense, or a delay. A TF conducting a rear guard operation follows the same axis of advance as the protected force at a distance prescribed by the main body commander and normally within artillery range. The TF commander establishes company team battle positions or AOs. When using AOs, he designates phase lines and checkpoints to control movement. The rear guard's responsibility begins at the main body rear boundary and extends as far from this boundary as the factors of METT-TC allow.

c. **Flank Guard.** A TF may receive a flank guard mission during a division movement to contact. The flank guard is responsible for clearing the area from the division main body to the flank guard's designated positions. The TF must be prepared to operate on a frontage that is greater than for other tactical operations. Usually, the area extends from the lead forward screen, along the flank of the formation, to either the forward edge of the battle area or the rear of the moving formation, tying in with the rear guard. Due to the complexities of this operation, the following detailed discussion of flank guard operations is provided.

(1) **Templates and Analysis.** Once the TF receives a flank guard mission, the S2 determines the type of threat facing the TF during its movement. This information is critical to the commander in his selection of appropriate formation and movement techniques. The IPB must incorporate the entire area of operations with analysis of the mobility corridors and avenues of approach extending from the FEBA to the objective. The S2, in conjunction with the TF engineer's terrain analysis, produces a situational template and an event template. He develops and inputs an ISR plan with specific reconnaissance objectives for subordinate units as the enemy overlay. Subordinate units verify the S2's situational template during reconnaissance and periodically sends enemy overlay updates back to the S2. The staff develops the DST to assist the commander in assessing the situation and making decisions.

(2) **Formation and Movement Techniques.** From the intelligence estimate the commander determines the formation and movement technique, accounting for the enemy situation and main body disposition. Movement techniques include alternate bounds, successive bounds, and moving guard.

(a) **Alternate Bounds.** The commander uses this technique when he anticipates strong enemy action against the flank. It requires slow movement by the main body.

(b) *Successive Bounds*. The commander uses this technique when he expects enemy action against the flank to be light and movement of the main body to include frequent short halts.

(c) *Moving Guard*. The commander uses this technique when he expects no enemy action on the flank and the main body will move with all possible speed. In the moving guard, an armor heavy company team executes the forward screen mission while traveling as in a movement to contact. The mortar platoon follows the forward screening company team to provide support. The scout platoon, normally with an armor section under OPCON, conducts a flank screen outside the tentative battle position line. The remaining company teams travel in column, along an axis or in sector, behind the forward screen. The commander uses this technique when the greatest enemy danger appears to be from the front.

(3) *Fire Support*. The fire support officer plans the flank guard operation the same as any offensive operation. Based on the IPB, he targets those enemy avenues of approach that threaten the force. He targets known and suspected enemy positions along the axis of advance or in the TF zone to support the forward screening element. During the operation, the TF executes its fire support plan as it would in movement to contact and defensive operations. On the forward screen, as the TF encounters enemy positions and subsequently destroys or fixes and bypasses them, it uses artillery to suppress the position. Should the enemy attempt to attack from the flank, the TF executes the fire support plan as it would for defensive operations to support the defense or delay.

(4) *Engineer Support*. The task force engineer considers the factors of METT-TC when conducting reverse planning of the flank guard missions. The task force engineer must identify all mobility as well as countermobility requirements of the task force. Based upon this analysis, engineer forces are typically task-organized throughout the depth of the TF formations to maintain maximum flexibility with priority of effort to mobility then countermobility. Priority of support is typically provided to the lead company team of the task force. Priority of work is to identify, mark, and bypass obstacles. If bypasses are not available then company or TF breaches are conducted. Countermobility obstacle plans are centered upon the rapid emplacement of situational obstacles by organic FASCAM systems (ground Volcano, MOPMS, Hornet). Successful execution of TF situational obstacles occurs through thorough planning, preparation, and rehearsals by the combined arms team to refine effective triggers to emplace the obstacles.

(5) *Air Defense*. The ADO develops a flexible plan to allow for the protection of the force as it changes posture between moving and stationary. He plans the TF air defense as he would in an offensive operation. Most assets are attached to maneuver elements and the main CP. Route protection or other areas go without support or rely on protection from main body ADA assets. The TF executes the air defense plan as in a movement to contact where a moving force may need to adopt a hasty defense quickly. Whether moving or stationary, air defense assets must be linked to the main body's air defense early warning net and the positioning of assets must protect not only the flank guard but also approaches into the main body.

(6) *Logistics*. The logistics planner has the same difficulties as in planning a movement to contact. He must plan for responsive and flexible support that may require the immediate resupply of ammunition and evacuation of casualties and equipment upon

contact. The planner identifies lateral supply routes to each battle position during the planning process. On-order control measures, LRPs, UMCPs, and AXPps are essential to the operation. As the TF begins its movement, the TF trains should travel abreast of the flank guard unit (close to the main body) to avoid exposing CSS elements to the enemy. Emergency resupply vehicles carrying ammunition, fuel, and other quickly expendable supplies are ready to respond to sudden requisitions due to enemy contact. Once the TF begins the fight, evacuation of wounded personnel and damaged equipment occurs along lateral supply routes all the way to the main body if that is where the support TF is located. Otherwise, the evacuation is back along the axis of advance.

(7) ***Orientation of Forces***. A unique aspect of the flank guard mission is the orientation of the forces and the direction they may be ordered to screen. While the force maneuvers forward along its assigned axis of advance or zone, phase lines control the movement of the company team elements. There should be a phase line on either side of each company team's battle position. The battle positions themselves are generally larger than in a purely defensive mission, partly due to the large frontage the TF must cover. Once an element detects the enemy and company teams adopt hasty defensive positions, these phase lines become boundaries for controlling the defensive battle. This gives the TF commander the option of designating company team sectors in addition to the battle positions already identified. Similarly, control of the reserve is accomplished through phase lines and checkpoints regardless of the actual direction of the maneuver. As a minimum, the following control measures are included:

- Phase lines (revert to boundaries on contact).
- Battle positions.
- TRPs.
- Axis of advance.
- Axis of advance of main body.
- Objectives (if used).

## **12-6. AREA SECURITY**

Area security refers to a force's mission to secure a specific area. Area security actions could include area reconnaissance and security of designated personnel, equipment, facilities (including airfield and seaports), main supply routes, lines of communication, and critical points. The TF is most often employed as an advance guard for a brigade, as part of a covering force for a division, or as an area security force during a stability or support action.

## **12-7. COVER**

A covering force accomplishes all the tasks of screening and guard forces. Unlike screening or guard forces, a covering force is tactically self-contained and capable of operating independently of the main body to develop the situation early and deceive, disorganize, and destroy enemy forces. Cover may be an offensive or defensive mission. The requirements placed upon the covering force, the command and control structure necessary for the forces involved, and the large areas of operations involved require an adequate level of command for successful accomplishment. The TF performs screen and guard missions. Covering force operations are normally an armored cavalry regiment mission for the corps or a task-organized brigade for the division. A covering force, or

portions of it, often becomes decisively engaged with enemy forces; therefore, the covering force must have substantial combat power to engage the enemy and still accomplish its mission. FA, engineers, air defense, intelligence resources, and CSS should be planned to support the cover mission.

### **Section III. BATTLE HANDOVER AND PASSAGE OF LINES**

Battle handover is a coordinated operation executed to sustain continuity of the combined arms fight and to protect the combat potential of both forces involved. Battle handover is usually associated with the conduct of a passage of lines.

#### **12-8. BATTLE HANDOVER**

Battle handover may occur during either offensive or defensive operations. During defensive operations, it is normally planned and coordinated in advance to facilitate execution and usually involves a rearward passage of lines. In the offense, it is situation-dependent and often initiated by a FRAGO. Battle handover normally occurs in the offense when one unit passes through or around another unit. Tactical and digital SOPs containing clear, simple, standardized procedures and control measures enhance a unit's ability to coordinate and synchronize actions quickly without experiencing a corresponding loss in momentum.

a. Battle handover occurs along a line forward of the stationary force. The brigade commander establishes this line in consultation with both stationary and passing TF commanders. The stationary TF commander normally determines the BHL location. This line is forward of the FEBA in the defense or the FLOT in the offense. The BHL is located where elements of the passing TF can be effectively overwatched by direct fires or supported by indirect fires of the forward combat element of the stationary TF until the battle handover is complete.

b. Physical handover normally occurs in the battle handover zone. Events may dictate that a force break contact forward of or behind the BHL, for example, when there is a gap between echelons of the attacking enemy force. Close coordination (physical, digital, or by FM voice) between the TFs involved in the handover allows them to coordinate and execute this process at the small-unit level.

c. The battle handover operation begins on order of the brigade commander of both units involved or when a given set of conditions occurs. Defensive handover is complete when the passing TF is clear and the stationary TF is ready to engage the enemy. These actions may occur at the same time. Offensive handover is complete when the passing TF crosses the BHL. The BHL is normally considered the LD for the attacking TF. Until the handover is complete and acknowledged by the commanders, the TF commander in contact is responsible for the fight.

d. Coordination for battle handover flows from the TF commander out of contact to the TF commander in contact. The coordination for a battle handover overlaps with the coordination for a passage of lines; the coordination for both should be accomplished at the same time. The tactical standing operating procedure (TSOP) should outline these coordination requirements to facilitate rapid accomplishment.

e. Digital systems assist the TF staff in its coordination and synchronization efforts for the operation. Each unit transmits or delivers a complete copy of its OPOD and overlays by either digital (FBCB2 or MCS) or conventional (hardcopy and acetate



overlay) means. Any changes made after initial distribution are updated immediately. The coordination effected between the two commanders includes--

- Establishing digital and FM voice communications.
- Providing updates of both friendly and enemy situations (digital, voice, and graphical).
- Coordinating passage points and routes and ensuring these are displayed on operational overlays (digital and conventional).
- Collocating C2 and exchanging liaison personnel (if required).
- Coordinating fires and fire control measures (direct and indirect) and ensuring these are displayed on operational overlays (digital and conventional).
- Provide updated obstacle overlays including self-destruct date time groups of emplaced FASCAM obstacles.
- Determining the need for and dispatching contact point representatives.
- Establishing and coordinating recognition signals (conventional).
- Exchanging locations of obstacles and related covering fires.
- Exchanging route information to include waypoints.
- Determining CS and CSS requirements.

f. Due to the fluid nature of a battle handover, commanders can use digital systems to speed the planning, coordination, and execution processes. FM voice should be planned; if digital capabilities are hampered, then FM should be utilized in coordinating and executing battle handovers.

### **12-9. PASSAGE OF LINES**

A passage of lines is the coordinated movement of one or more units through another unit. It is normally conducted when at least one METT-TC factor does not permit the bypass of a friendly unit. A passage of lines is a complex operation requiring close supervision and detailed planning, coordination, and synchronization between the TF commanders of the unit conducting the passage and the unit being passed. The primary purpose of a passage of lines is to transfer responsibility for an area from one unit to another. The TF or its subordinate units execute a forward or rearward passage of lines (Figures 12-2 and 12-3). A passage of lines may be conducted to--

- Continue an attack or counterattack.
- Envelop an enemy force.
- Pursue a fleeing enemy.
- Withdraw covering forces or MBA forces.

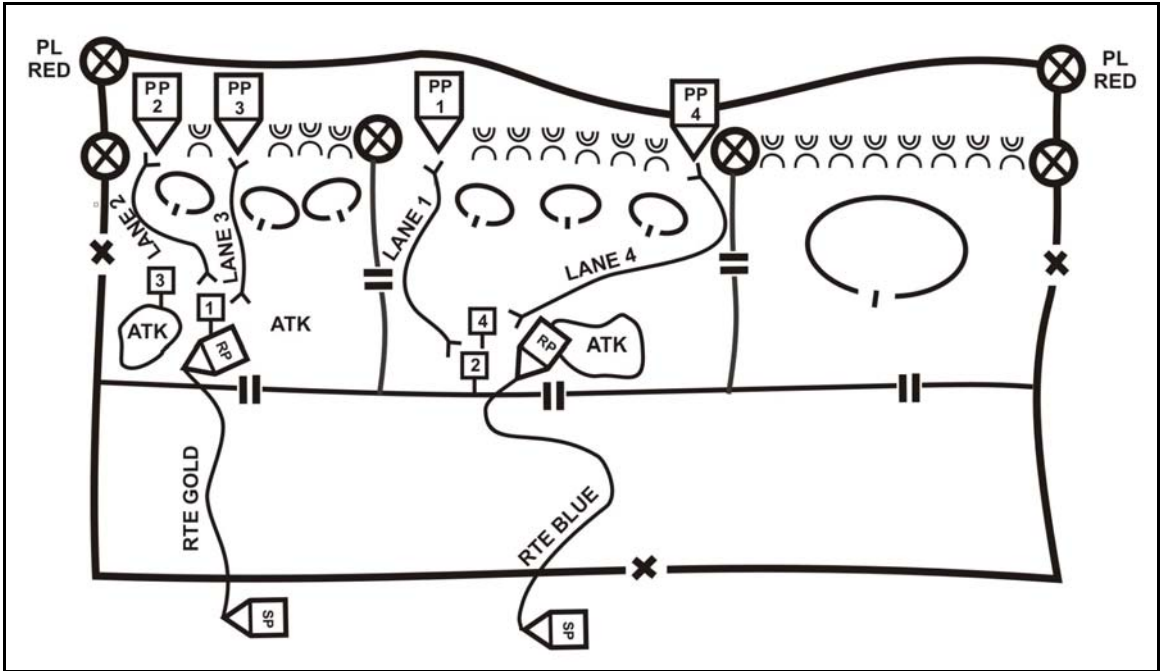


Figure 12-2. Forward passage of lines.

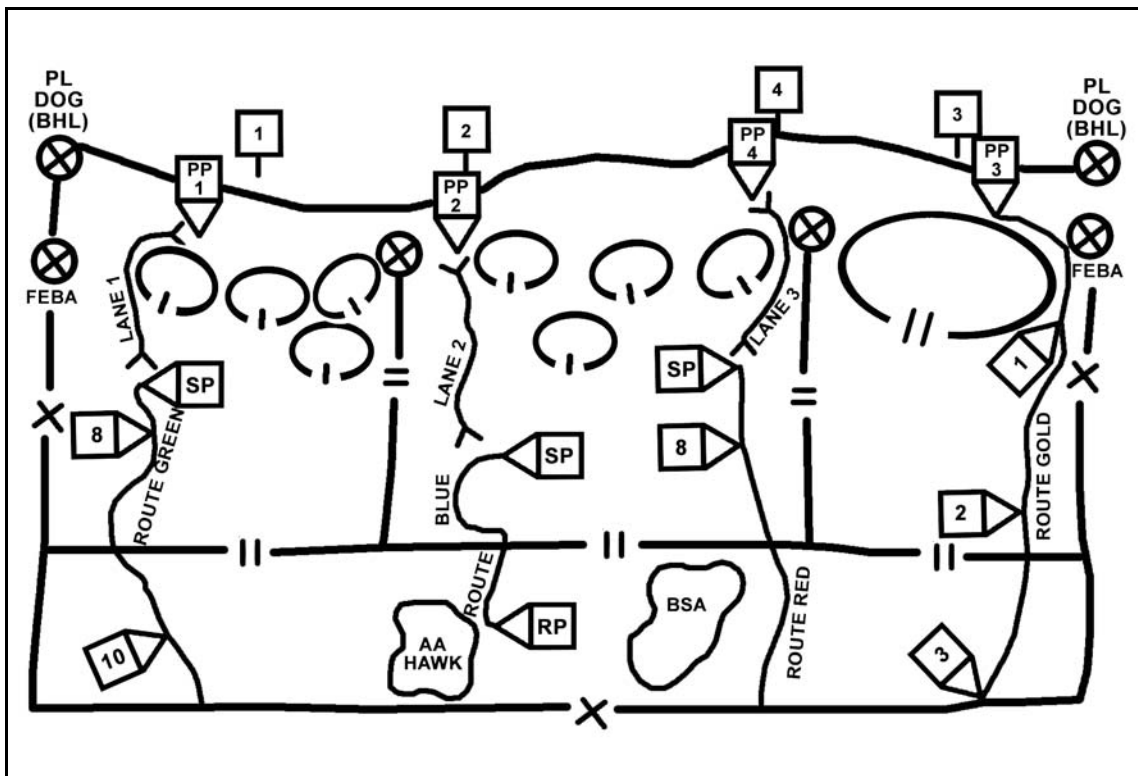


Figure 12-3. Rearward passage of lines.

a. **Planning.** The division or brigade plans and conducts a TF passage of lines. Units involved in a passage of lines must conduct detailed coordination to ensure they maintain positive control to avoid fratricide, speed the passage, and reduce vulnerability to enemy

attack. The TF S2 and staff conduct the IPB, and the S3 prepares his tentative plan based on stationary force restrictions, the IPB, and parameters established by the TF commander. The S3s of the passing TF and stationary TF coordinate routes, checkpoints, linkup points, and passage points via FBCB2, MCS, or conventional means. Planners must evaluate the following basic considerations and integrate them into the planning process.

(1) ***Terrain Management and Control Measures***. Terrain management is critical to successful completion of a passage of lines. Terrain is controlled through the sharing of digital overlays that contain the following:

- Routes (primary and alternate).
- Checkpoint data.
- Friendly and enemy unit locations and status.
- Passage points.
- Fire support control measures.
- Obstacle types and locations.
- CSS locations and descriptions.

(2) ***Liaison***. Stationary and passing TFs exchange information by way of extensive and detailed coordination and liaison before mission execution.

(3) ***Communications***. Communication architectures, digital systems, COMSEC, recognition signals, and communication procedures and requirements must be identified, synchronized, and integrated into the OPLAN. Communication ensures units share data and pertinent combat information and maintain a common relevant picture.

(4) ***Mission Transition***. Plans for the conduct of the passage must facilitate transition to the subsequent missions of both the passing and stationary TFs.

(5) ***Exchange of Zone, Sector, or Area of Operations Control***. Control of the zone, sector, or area of operations passes from one TF to the other at a time and place directed by the higher common commander or as mutually agreed upon by the stationary and passing TF commanders.

(6) ***Routes***. The passing TF moves on multiple routes through the passed TF and avoids the use of assembly areas. It does not halt within the passed TF's forward positions.

(7) ***Employment of Deception and Smoke***. Deception and smoke operations can deceive the enemy as to actual unit locations and passage points.

(8) ***Control Measures***. Establish graphic control measures to ensure positive control of both the stationary and passing units.

(9) ***Location of Stationary TF and Obstacles***. The location and obstacle emplacement of the stationary TF may impact planning and execution of the forward passage of lines.

**NOTE:** The terrain and number of the passage lanes determine the speed and disposition of the passing TF as it crosses the LD. When conducting a forward passage in preparation for a deliberate attack, it may be important to create passage lanes with sufficient width to allow the passing force to move in a tactical formation appropriate to the operation, such as company team or platoon wedge.

b. **Field Artillery Activities.** The TF FSO reviews the fire support plan of the stationary unit and conducts direct coordination to ensure that a clear understanding exists between the passed and passing units on the established FSCMs. He does so through the transfer of digital fire support overlays between the two FSEs via AFATDS. Procedures to establish fire support battle handover or transfer of control are also identified and approved by the maneuver commander. Terrain and route management for artillery batteries and their support assets are especially important due to potential terrain limitations. All artillery units, to include reinforcing and DS reinforcing units, must be positioned to support the passage if enemy contact is possible during the operation.

c. **Engineer Activities.** A passage of lines may require either the reduction of some obstacles or the opening and closing of lanes through friendly obstacles. The passing TF engineer must coordinate with the stationary unit engineer via digital means or face-to-face meeting. As a minimum, this coordination must address the following:

- Location and status of friendly and enemy tactical obstacles.
- Routes and locations of lanes and bypasses through friendly and enemy obstacles.
- Transfer of obstacle and passage lane responsibilities.
- Description of lane marking materials.
- Description of far and near recognition markers.

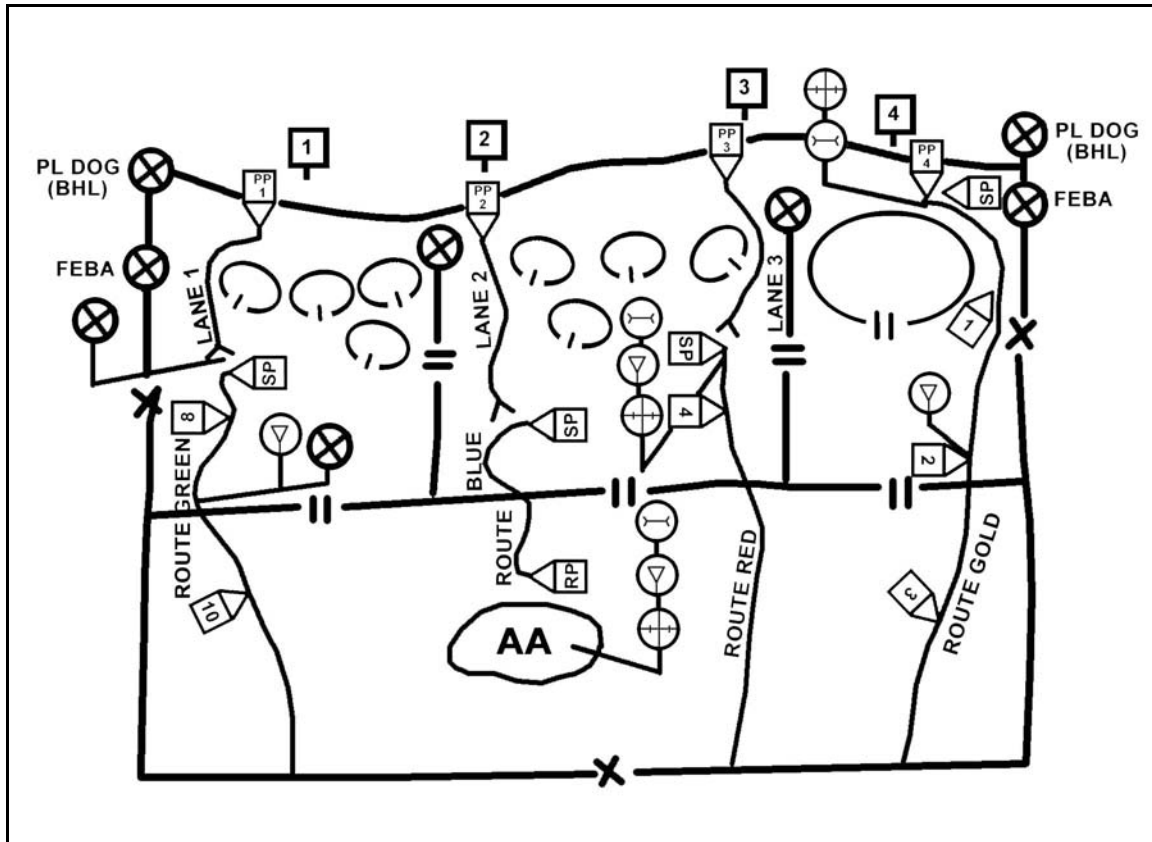
d. **Air Defense Artillery Activities.** During the conduct of a passage of lines, units participating in the operation present a lucrative target for air attack. The passing commander coordinates ADA protection with the stationary force commander for ADA coverage during the passage of lines. This method allows the passing force's supporting air defense assets to conduct a move at the same time. If the passing force requires static air defense, then it must coordinate the terrain with the stationary TF's S3. To ensure the passing force's ADA assets are incorporated into the stationary force's air defense early warning net, the stationary force uses FAADC3I for ADA coordination. If the stationary TF is not equipped with FAADC3I or Sentinel radars, commanders should consider positioning these assets in the stationary TF area to provide more effective early warning and air defense.

e. **Combat Service Support Activities.** The CSS plan is integral to a successful passage of lines. CSS assets are positioned to support the passage. UMCPs and emergency refueling points are positioned where they can best keep lanes open and vehicles moving. Figure 12-4, page 12-14, shows the CSS plan for a rearward passage of lines.

f. **Health Services Support Activities.** Conducting a passage of lines presents a challenge for the HSS planner. There will be a number of MEDEVAC units using the same air and road networks. Coordination and synchronization are essential if confusion and over-evacuation are to be avoided. The medical elements of the force manning the line should provide area support to the force passing through; this allows continued mobility for the moving force. Examples of information that should be coordinated include--

- Radio frequencies and call signs.
- Operation plans and TSOPs.
- Location of MTFs.

- Location of CCPs and AXP.
- Main supply route, forward arming and refueling points, and A2C2 data.



**Figure 12-4. Combat service support plan for rearward passage of lines.**

### 12-10. FORWARD PASSAGE OF LINES

In a forward passage of lines conducted as part of an attack, both the stationary and passing TF commanders must be aware of the passing TF's objective. This awareness is especially important if the stationary TF must provide supporting fires. The stationary TF and forward passing unit, through an exchange of combat information, share data needed to effect a passage of lines in a timely and safe manner.

a. On receipt of an order, the passing TF commander begins preparing his passage of lines plan by conducting a reconnaissance while concurrently updating the information received from the stationary TF. For example, the passing TF receives an FBCB2 operations overlay that delineates routes to the contact points as well as the location of the actual linkup site. The TF commander and staff of the passing unit meet representatives from the stationary TF at designated contact points to conduct coordination. During the physical reconnaissance, the S3 from the passing TF updates the initial operations overlay, incorporating information received from the stationary TF by adding pertinent control measures. Upon completion, the S3 forwards this overlay to the main CP. Based on this information, the staff completes development of the plan. Once approved by the commander, additional control measures are added to the operations overlay as necessary to complete the plan.

b. The main CP forwards the validated operations overlay update from the stationary and passing TFs, brigade, and subordinate units to the liaison teams. This technique allows the S3 and TF commander to develop their scheme of maneuver for the passage of lines on a digital overlay concurrent with reconnaissance. At the conclusion of the reconnaissance and subsequent coordination with the stationary TF, the revised TF plan is distributed digitally by way of FBCB2 to subordinate units and higher headquarters.

### **12-11. REARWARD PASSAGE OF LINES**

Typically, a rearward passage of lines occurs within a defensive framework in which elements of the covering force operate forward of the MBA. MBA forces are the stationary unit in a rearward passage of lines. The covering force withdraws through them, handing off control of the fight at the battle handover line.

a. To facilitate a rearward passage of lines, the stationary force commander designates--

- The battle handover line.
- Contact points forward of the BHL.
- Passage points along the FEBA.
- Lanes to the rear of the MBA.

b. Once he prepares the overlay, the stationary commander transmits it and any amplifying information to the passing force commander by way of FBCB2 or MCS.

c. During a passage of lines, unit density in a relatively small maneuver space may cause problems in the ability of the commanders to maintain the common operational picture in relation to both the passed and passing units. The stationary and passing commanders should determine the best method of exercising C2 to avoid slowing the tempo of the operation and to reduce fratricide potential.

### **12-12. REHEARSAL**

During the rehearsal, the TF commander ensures that each organization knows when and where to move as well as how to execute the required coordination. Digital communications checks ensure connectivity and interoperability. Other rehearsal items include--

- Fire support observation plan, target execution, communication linkages, and mutual support operations. Confirm fire support control measures. Review unit routes and positioning.
- Locations and descriptions of obstacles, lanes, bypasses, and markings. Confirm locations of any engineer stockpiles.
- Air defense weapons locations, early warning communications, air threat, and weapons control status.
- Passage points, routes, and recognition procedures. Confirm these and review numbers of vehicles by type expected at each passage point. Rehearse route management, contact points, and use of guides.
- Locations for and movement of CSS units. Rehearse these, along with mutual support arrangements and any transfer of supplies.
- Locations of aid stations, ambulance exchange points, and casualty evacuation procedures (rehearse these).

### Section IV. LINKUP OPERATIONS

Linkup operations, which join two or more friendly forces, are conducted to--

- Complete the encirclement of an enemy force.
- Assist breakout of an encircled friendly force.
- Join an attacking force with a force operating in the enemy's rear area.
- Make contact with other forces on a noncontiguous battlefield.

Before commencing a linkup operation, the headquarters elements of the stationary force and linkup force must share data including COMSEC procedures and digital graphic overlays consisting of--

- Primary and alternate linkup points.
- Checkpoints and waypoints information.
- Unit disposition and activity (friendly and enemy).
- Locations and types of obstacles.
- Fire control measures including RFLs.

#### 12-13. CONTROL DURING LINKUP OPERATIONS

The stationary and linkup force must maintain positive control during linkup operations to prevent inadvertent fratricidal engagements. They use FBCB2, ABCS, and FM voice systems as required to share combat information and to identify friend from foe positively. It is imperative that both the linkup and stationary units conduct precombat communications checks before the operation begins to ensure that connectivity and interoperability between digital systems is established and maintained.

a. The S6s of the two linkup units are integral to successful linkup operations when both units are digitally equipped. These officers must ensure that units address both primary and alternate forms of communication during planning and that they synchronize both manual and digital systems used in support of the linkup operation and integrate these into the linkup plan.

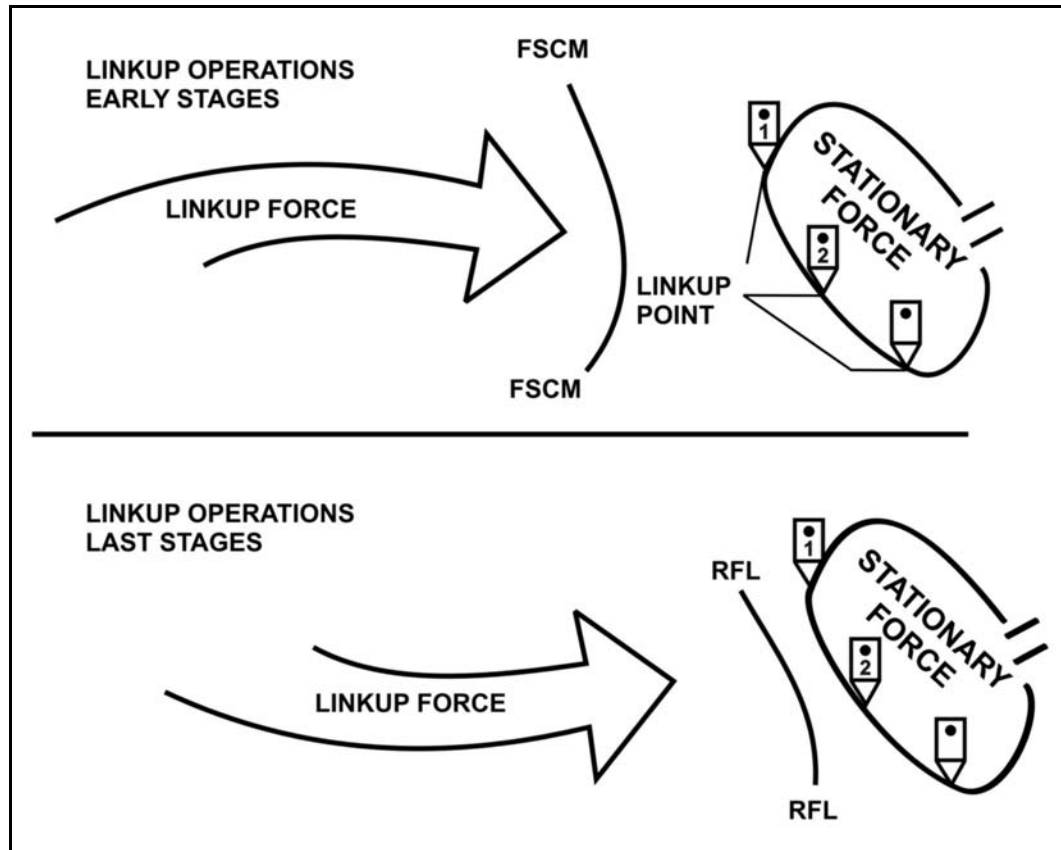
b. Special requirements related to digital operations must be identified. The following are examples:

- Exchange of unit IP address databases.
- SINCGARS and EPLRS hop set data.
- COMSEC requirements.
- Positioning of EPLRS position server links.
- Modifications to digital communications structure.

#### 12-14. FORMS OF LINKUP

Linkup operations take one of two forms: linkup of a moving force and a stationary force or linkup of two moving forces.

a. **Linkup of a Moving Force with a Stationary Force.** To ensure the forces join without engaging one another, linkup points are selected at locations where the axis of advance of the linkup force intersects the security elements of the stationary force (Figure 12-5). These points must be readily recognizable to both forces and should be posted on both digital overlays and conventional maps in case of digital communication loss. Alternate points are chosen so the units are prepared in case enemy activities cause linkup at places other than those planned. The number of linkup points selected depends on the terrain and number of routes used by the linkup force.



**Figure 12-5. Linkup of a moving force with a stationary force.**

(1) The communications section is critical to linkup operations. Digital communications are used to transmit and share combat information data. However, use of digital means depends on METT-TC factors and the ability to maintain digital linkages between the moving unit and stationary unit.

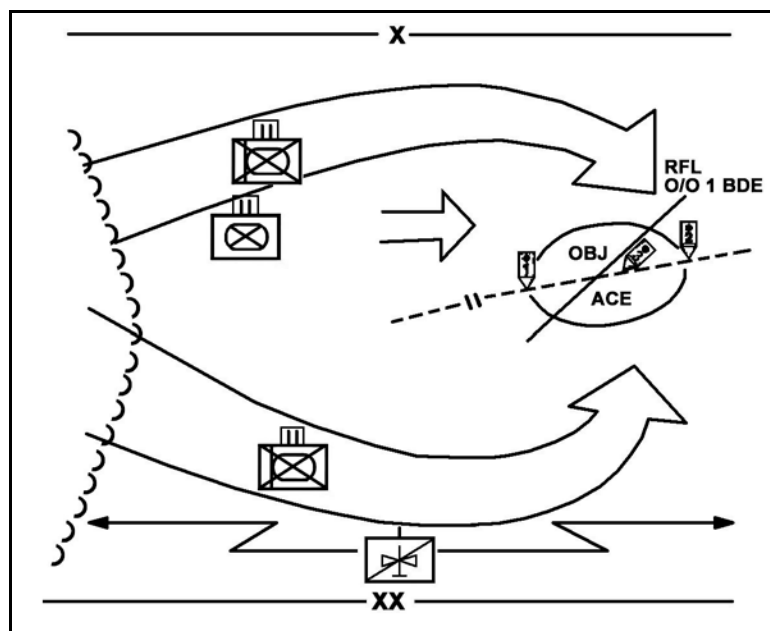
(2) To facilitate a rapid passage of lines and to avoid inadvertent engagement of friendly forces, personnel in the linkup force must be thoroughly familiar with recognition signals and plans. As required, stationary forces assist in the linkup by opening lanes in minefields, breaching or removing selected obstacles, furnishing guides, providing routes with checkpoints, and designating assembly areas.

(3) When linking up with an encircled force, the TF carries as much materiel as possible during the linkup operation. This materiel includes Classes I, III, V, and VIII. If an enemy force has encircled the stationary force, the TF carries additional supplies and materiel requested through to the brigade S4 before the linkup takes place. The TF S4 ensures that each company team has received the FBCB2 CSS overlay depicting MSRs, traffic control points, AXPs, and UMCPs.

b. **Linkup of Two Moving Units.** Linkup between two moving units is one of the most difficult operations (Figure 12-6, page 12-18). It is normally conducted to complete the encirclement of an enemy force. Primary and alternate linkup points for two moving forces are established on boundaries where the two forces are expected to converge. As linking units move closer, positive control is coordinated to ensure they avoid firing on one another and to ensure the enemy does not escape between the two forces. Again,



using digital systems facilitates planning, synchronization, execution, and fratricide avoidance.



**Figure 12-6. Linkup of two moving units.**

c. **Actions Following Linkup.** When the linkup is complete, the linkup force may join the stationary force, pass through the stationary force, go around the stationary force, or continue the attack.

(1) If the linkup force is to continue operations with the stationary force, a single commander for the overall force is designated. Objectives for the linkup provide for dispersion in relation to the stationary force. The linkup force may immediately pass through the perimeter of the stationary force, be assigned objectives within the perimeter, or be assigned objectives outside the perimeter, depending on the mission.

(2) When the brigade directs a linkup operation, it normally establishes a restrictive fire line for both TFs to ensure positive control and reduce the risk of fratricide. It transmits these RFLs to both units by way of a digital overlay, and they are subsequently adjusted and overlays updated as one force moves toward the other. This process continues until a single RFL is established between the forces. Usually, this is the point on the ground where the two forces plan to establish contact.

d. **Planning.** The linkup is a complex operation requiring detailed planning and coordination. Plans for a linkup are coordinated as far in advance as possible. The two forces carefully define and coordinate their schemes of maneuver with certain attention given to graphic control measures, communications, and the subsequent mission to be performed by each force after linkup operations are completed. Alternate linkup points are planned and lend flexibility to the overall operation.

(1) The two units establish liaison during planning and continue it throughout the operation. Liaison parties must have the capability to communicate digitally with their parent unit through the TI. As the distance closes between the forces, the requirement to

track movement through FBCB2 and maintain close liaison increases. Use of Army aircraft can improve and expedite this process.

(2) Linkup operations frequently require a passage of lines. Once through friendly lines, the TF moves out as in an exploitation to effect the linkup. Speed, aggression, and boldness characterize this action. If possible, the linkup force avoids enemy interference with its mission and concentrates its efforts on completing the linkup. If enemy forces threaten the successful accomplishment of the mission, they are either destroyed or bypassed and reported.

(3) The headquarters directing the linkup operation must establish command relationships and responsibilities for the forces involved. Both the linkup force and the force with which linkup is to be made can remain under control of the directing headquarters. Operational plans must prescribe the primary and alternate day and night identification and recognition procedures, vehicle systems, and manmade materials used to identify friend from enemy.

(4) The communication plan includes all essential frequencies, secure variables, IP addresses, and communication needlines to maintain communication between the two forces.

(5) Logistical support requirements may be greater during linkup operations than during other offensive actions. Additional considerations for planning logistical support in linkup operations include--

- Resupply of stationary unit.
- Fuel requirements.
- Duration the objective is to be held (METT-TC).
- Operations after the linkup is completed (for example, attack, withdraw, or defend).
- Transportation requirements for special purpose forces (for example, air assault and special operation forces).
- LOC security requirements.

(6) Supply requirements for a linkup operation may exceed the transportation capability of the TF. The TF may have to request additional vehicles from higher headquarters, Army aviation support, or both.

(7) In linkup operations involving airborne and air assault units, the units assaulting the objective area have priority for supply by air. Supplies for the ground linkup forces normally move by land transportation. However, when the linkup and an airborne or air assault force plan to defend the objective area jointly, supplies for the linkup force may be flown into the objective area and stockpiled.

(8) Evacuation of equipment, wounded in action (WIAs), and EPWs may create major problems for the linkup force. If supply routes are open, normal evacuation procedures apply. When ground routes are not secure, helicopters are used for the evacuation of casualties and prisoners. Damaged equipment may be moved forward with the linkup forces until it can be evacuated at the first suitable opportunity.

e. **Preparation.** Due to the time-sensitive nature of linkup operations, the commander issues his order digitally. If time is available, he conducts a rehearsal at higher headquarters. If time is not available, the commander walks the linkup commander through the operation. He stresses the linkup and coordination required to reduce the potential for fratricidal engagements between the linkup forces. In addition, he ensures

that each TF commander is prepared to respond to an enemy meeting engagement or attack before the linkup. The TF FSO is an integral member of the team that plans linkup operations. He is responsible for the coordination, synchronization, dissemination, and monitoring of the FS plan and FSCMs. He is also accountable for the conditions and methods for changing the FS plan or control measures.

f. **Execution.** Depending on the enemy situation and METT-TC, the initial conduct of the linkup operation may be identical to an exploitation or attack. During the operation, the brigade commander monitors the progress and execution through data passed using FBCB2 and other ABCSs to ensure positive control measures established are followed or adjusted as required. Adjustments made to the OPLAN are coordinated and synchronized by way of digital systems. If a FRAGO is passed by FM voice, a digital follow-up is entered and transmitted through FBCB2 to ensure all units are aware of the change. The following discusses the digital procedures that may be used when friendly forces are conducting a linkup.

(1) As the linkup forces begin their maneuver, they establish digital and FM voice communications and maintain them throughout the operation. As each force maneuvers, progress is tracked by way of FBCB2, and adjustments to the linkup plan are made as METT-TC dictates. For example, if two forces are involved in the operations and one is unable to travel at a speed commensurate with the plan, the linkup location may require adjustment.

(2) In nondigitized units, as the linkup forces near each other, the speed (momentum) of the operation may be slowed to maintain positive control and to prevent fratricide. In this case, commanders must be vigilant and ensure enemy forces do not slip between the two closing forces. Momentum of a linkup operation should not slow for the digitized TF since the maneuver and movement of all forces can be tracked by way of FBCB2 and other ABCSs.

(3) The TF FSE changes or activates the FS control measures established for the operations based on the progress of the forces and the enemy situation. All changes are provided to the FSEs of the maneuver units involved in the linkup through FBCB2 or AFATDS. As the maneuver units draw closer to one another, CFLs are canceled and a restrictive fire line (RFL) is placed into effect to prevent fratricide between the converging forces. Once the linkup has occurred, FS for the brigade is organized as per the higher headquarters plan for future operations.

(4) The TF commander positions himself to observe the progress of the operation and maintains both digital and FM voice communications with the S3. The commander of a digitized TF is more flexible in positioning since he can maintain a composite picture of the progress of both maneuver units digitally and adjust the linkup plan as required. The TF S3 is positioned based on the operational concerns expressed by the TF commander. For example, if a certain flank is of concern to the commander during the operation or a supporting attack is required to penetrate the enemy's lines, then the TF S3 locates where he can best observe the TF's secondary action.

## Section V. RIVER CROSSING OPERATIONS

There are three types of river crossing operations: hasty, deliberate, and retrograde. TFs do not make deliberate or retrograde crossings independently; these are centralized operations where the controlling echelon is a division or brigade. (For a detailed discussion of these operations, see FM 90-13.)

### 12-15. GENERAL CONSIDERATIONS

TFs routinely make hasty crossings and reorganize in order to maintain the momentum of operations. The information provided through ABCS reduces uncertainty about the enemy and friendly situation, enabling the TF to move rapidly to undefended or lightly defended crossing sites where it uses all available means to push its company teams across the river and onto objectives on the far side.

a. A hasty river crossing is a continuation of an attack across the river, with no intentional pause at the water to prepare, so that there is no loss of momentum. This technique is possible when enemy resistance is weak and the river is not a severe obstacle.

b. TFs cross in their respective zones at multiple points and as quickly as possible. The TF may require the use of organic, existing, or expedient crossing means. Additional support from the division or corps may be necessary if bridging requirements exceed the capability of engineers augmenting the TF. Bridge companies are controlled at corps level. Their support is available only when headquarters has taken purposeful action to position the assets at the right time and place to assist a TF's hasty crossing. The TF must coordinate for support through the brigade early in the planning process.

c. Small gaps, streams, and small rivers that prohibit vehicles from advancing are encountered more frequently than large gaps and rivers that require extensive bridging. When terrain or enemy conditions dictate, each TF should request organic mobile crossing assets that enable it to install bridges quickly, cross small gaps, and recover the bridges for future crossings. Follow-on bridges, such as the medium-girder bridge (MGB), may need to be positioned at these gaps before assault bridges are removed so that following forces and support units can maintain the pace of the TF. The two types of hasty crossings are dry-gap and wet-gap crossings.

(1) **Hasty Dry-Gap Crossing.** Antitank ditches and craters are normally what TFs encounter as a dry-gap obstacle. Dry riverbeds may also present a crossing problem to vehicles. TFs can use the M9 ACE to push down the sides of ditches or to fill in craters. Substantial fill material placed in the dry gaps allows the passage of combat vehicles. Follow-on forces can improve and maintain the crossing site for wheeled-traffic use. The AVLB or Wolverine, if available, is suited for spanning streambeds, AT ditches, craters, canals, partially blown bridges, and similar obstacles without significant loss of momentum to the TF. The AVLB and Wolverine both launch their bridges in 2 to 5 minutes and retrieve their bridges in 10 minutes. An AVLB crosses gaps of up to 17 meters in length (without prepared abutments) with a military load classification of 70. A Wolverine has increased capability; it crosses gaps up to 24 meters with a military load classification of 70. Bridges should be left in place across the gaps only as long as it takes to cross the TF, then replaced with other fixed bridging, if necessary.

(2) **Hasty Wet-Gap Crossing.** Bank conditions, the depth and width of the wet gap, and the current's velocity determine whether the TF can cross its vehicles by fording,

swimming, or if other bridging assets are required. Identifying wet gaps early and deploying the required resources allow hasty crossings of known or anticipated gaps to occur. The following are general planning factors for hasty wet-gap crossings. In depth crossing site considerations and planning factors for commanders and staffs are found in FM 90-13, Chapter 7.

(a) Because vehicles drain rapidly when exiting, initially firm banks tend to deteriorate rapidly from multiple uses of the same exit point. The existence of mud or surface irregularities further degrades the percent of the slope that vehicles can overcome. When selecting a fording site in a wet-gap crossing, the depth of the water is the most significant factor. The depth of the water in one crossing area may change due to bottom surface mud or irregularities (boulders and potholes).

(b) If possible, the TF crosses the water obstacle at multiple points across a broad front by swimming or fording mounted or dismounted forces. It makes the crossing as soon as its elements reach the obstacle. As the bulk of the TF crosses the water, minimum forces remain to secure the crossing sites.

(c) The TF may use expedient crossing means if they are readily available and can be transported to the crossing site. Scouts and other reconnaissance elements should note material or existing features that could be used as expedient crossing devices. These include culvert pipe, lumber or cut timber, or war-damaged equipment. The pipe links system, which consists of bundles of 8-inch, high-density plastic pipes chained together, can fill gaps up to 9 meters deep and support up to 70 tons.

(d) A well practiced SOP reduces the necessary planning and preparation time. A concise order clearly articulating the commander's intent allows exploitation wherever subordinate units successfully force a crossing. When possible, advance elements seize existing crossing means intact and ahead of the main body.

(e) When facing negligible or light enemy resistance on both banks, the force does not have to clear all enemy forces from the river to conduct a hasty crossing. It capitalizes on the speed of the crossing and the limited ability of the enemy to oppose the crossing effectively.

## **12-16. ASSAULT OF THE CROSSING SITE**

A TF assault across a river normally begins with an attack to secure terrain on the exit bank. This may involve an air assault by infantry elements, an assault crossing using pneumatic boats, or an infiltration by swimming or rope bridges. Regardless of crossing technique, the dismounted elements constitute the TF's assault force.

a. **Air Assault Crossing.** An air assault is the fastest and most preferred crossing method. The following considerations apply when planning an air assault as part of the TF river crossing. (Refer to Appendix J and FM 90-4 for detailed discussion of air assault operations.) Helicopters--

- Require indirect approaches to avoid detection.
- Provide the element of surprise.
- Give greater flexibility to emplaced personnel and equipment.
- Provide the rapid insertion of forces into the area where the enemy is located, if an LZ is available.
- Are greatly affected by weather conditions.

- Must be a high AD priority at the river, requiring suppression of enemy AD efforts.
- Require the separation of troops from their vehicles and equipment.
- Are vulnerable to armored counterattacks and require a quick ground linkup.

b. **Rubber-Boat Crossing.** The following considerations apply when using rubber boats in an assault crossing. Rubber boats--

- Offer great opportunity for surprise in a silent-paddle crossing.
- Are a relatively fast means of crossing, especially when using outboard motors.
- Maneuver well in the water.
- Require limited, if any, entry-bank preparation and no preparation on the exit bank.
- Require the separation of troops from their vehicles and heavy equipment.
- Have limited carrying capacity, particularly AT weapons.
- Provide limited protection, mobility, firepower, and communications on the exit bank.

c. **Organization for Boat Crossing.** The specific organization used depends on METT-TC factors, particularly the size of the bridgehead, the distance to exit-bank objectives, and the nature of the enemy's defense. Regardless of these factors, the TF organizes into support and assault forces and is assisted in the assault by other units in support by fire positions.

(1) **Support Force.** The support force is normally the BFV and tanks of the company team whose infantry is conducting the assault crossing. This force establishes a support by fire position along the friendly bank before the assault. It uses night-vision and thermal sights to locate enemy positions. It also develops a fire plan to engage these positions and to provide suppressive fires on all suspected positions. When directed to engage, the support force destroys all known and suspected positions. The assault force commander, usually the TF commander, directs the support force commander, usually the XO, to lift or shift suppressive fires as necessary. Supporting artillery and the mortar platoon provide indirect fire support and effects.

(2) **Assault Force.** The first assault wave moves the force across covertly. This force attempts to provide sufficient security on the far shore so that the second and later assault waves can cross if surprise is lost. Each assault company team receives engineers that accompany the assault force to its objective, helping it fight through obstacles and prepared defenses. The engineers help the assault force establish hasty defenses after it has seized its objectives. The first assault wave carries--

- Rifle platoons.
- Attached assault engineers.
- Forward observers.
- The command group.

(a) **First Assault Wave.** The organization of the first wave permits rapid deployment of the force into a tactical formation on the far shore. Individual boatloads retain unit integrity at the lowest level. The two basic boatload configurations are the rifle squad boat and the rifle platoon headquarters boat.

- The first wave of the assault may consist of three company team flotillas crossing on line. TFs do not have a prescribed crossing formation. Each company team crosses in its own AO and attacks its own objectives.
- Platoon boat groups form into company team flotillas. The company team commander commands the guide boat in the center platoon. The company team command group disperses between boats, filling in vacant boat positions.

(b) *Second Wave.* The second wave carries company team aid stations and may include the TF command group. If sufficient AD systems are in place to cover the crossing area, the brigade may release some of the augmenting AD teams to cross in the second wave as MANPADS teams. The second wave also transports additional material and ammunition that is not required for the initial assault but is necessary to establish a defense. This may include antiarmor weapons, mortars, ammunition, laser designators, mines, or pioneer tools.

(c) *Subsequent Waves.* The immediate movement of some AT weapons across to support the assault element is essential if an armor threat exists. As vehicles carry all heavy AT weapons, engineers concentrate on moving antiarmor systems or vehicles carrying heavy weapons across immediately after the second wave. Engineers begin bank preparations on both the near and far shore, using hand tools and heavy equipment where possible. They may ford an M9 ACE or deep ford a bulldozer to get a winch capability to the far shore. If necessary, Bradley vehicles can ford with towing assistance. If absolutely necessary, rafting can be used, but this is a high-risk operation and is vulnerable to enemy indirect and direct fire systems. (For a detailed description of assault crossing techniques and procedures, see FM 90-13.)

## **Section VI. COMBINED ARMS BREACHING OPERATIONS**

Obstacle breaching is the employment of a combination of tactics and techniques to project combat power to the far side of an obstacle. Success will depend on the TF effectively applying the breaching fundamentals of SOSRA. Breaching is a synchronized combined arms operation under the control of a maneuver commander. Breaching operations begin when friendly forces detect an obstacle and initiate breaching fundamentals and end when friendly forces destroy the enemy on the far side of the obstacle or when battle handover has occurred between a unit conducting the breaching operation and follow-on forces. Effective breaching operations allow friendly maneuver in the face of obstacles.

### **12-17. BREACH TENETS**

Successful breaching operations are characterized by applying breach tenets. The tenets are applied whenever an obstacle is encountered, whether friendly forces are conducting an attack or route clearance operations. The breach tenets are--

- Intelligence.
- Breaching fundamentals.
- Breaching organization.
- Mass.
- Synchronization.

a. **Intelligence.** Critical to a commander's success is the ability to identify how the enemy applies obstacles to the terrain. The commander and staff conduct intelligence

---

preparation of battlefield to develop initial SITEMPs and priority intelligence requirements. Intelligence gathered by reconnaissance forces is essential to developing a finalized SITEMP and final point of breach locations. Unverified enemy SITEMPs may cause friendly forces to deploy to reduce obstacles early, waste mission time attempting to locate non-existent obstacles, develop COAs using ineffective obstacle reduction methods, or become surprised by an obstacle. Augmentation of reconnaissance forces by engineer squads or sections may be utilized as part of the overall ISR plan. Examples of obstacle intelligence (OBSTINTEL) requirements are--

- Location of existing or reinforcing obstacles.
- Orientation and depth of obstacles.
- Soil conditions (determines ability to use mineplows).
- Lanes or bypass locations.
- Composition of minefields (buried or surface laid antitank and antipersonnel mines).
- Types of mines and fuzes (determines effectiveness of mechanical or explosive reduction techniques).
- Composition of complex obstacles.
- Location of direct and indirect fire systems overwatching obstacle.

b. **Breaching Fundamentals.** The breach fundamentals--suppress, obscure, secure, reduce, and assault --always apply; however, they must adapt to the varying factors of METT-TC.

- Suppression protects friendly forces reducing and maneuvering through an obstacle. Successful suppression typically initiates the rest of the actions at the obstacle.
- Obscuration degrades enemy observation and target acquisition of the enemy forces while concealing friendly force reduction and assault activities. Obscuration planning factors include wind direction, type of obscuration systems available (mechanical smoke, artillery delivered, mortar delivered, smoke pots), and the capabilities and limitations of these systems. Typically the most effective placement of obscuration is between the obstacle and the overwatching enemy forces.
- Friendly forces secure the point of breach to prevent enemy forces from interfering with the reduction of lanes and passage of assault forces. The breach force must be resourced with sufficient combat power to secure the point of breach.
- Reduction is the creation of lanes through an obstacle. Reduction can not be accomplished until effective suppression and obscuration is achieved and the point of breach secured. The breach force will reduce, proof, and mark the required number of lanes to pass the assault force through the obstacle. Follow-on forces will continue to improve and reduce the obstacle when required.
- The assault force's primary mission is to seize terrain on the far side of the obstacle in order to prevent the enemy from placing or observing direct and indirect fires on the reduction area.



c. **Breaching Organization.** Commanders develop COAs which organize friendly forces into a support force, a breach force, and an assault force to quickly and effectively execute the breach fundamentals (Table 12-1).

Breaching Organization	Breaching Fundamentals	Responsibilities
Support force	Suppress Obscure	Suppress enemy direct fire systems covering the reduction area. Control obscuring smoke. Prevent enemy forces from repositioning or counterattacking to place direct fires on the breach force.
Breach force	Suppress (provides additional suppression) Obscure (provides additional obscuration in the reduction area) Secure (provides local security) Reduce	Create and mark the necessary lanes in an obstacle. Secure the near side and far side of an obstacle. Defeat forces that can place immediate direct fires on the reduction area. Report the lane status and location.
Assault force	Assault Suppress (if necessary)	Destroy any enemy forces capable of placing direct fires on the reduction area from the far side of an obstacle. Assist the support force with suppression if the enemy is not effectively suppressed. Be prepared to breach follow-on and protective obstacles after passing through the reduction area.

**Table 12-1. Breaching organization.**

- Support force responsibilities are to isolate the reduction area with direct and indirect fires, suppress enemy’s direct and indirect fire at the point of breach, and control obscuration.
- The breach force must have sufficient combat power to secure the point of breach as well as sufficient reduction assets to reduce the required number of lanes through the obstacle. CFZs should be activated at the point of breach prior to commitment of the breach force to protect it from enemy indirect fires.
- The assault force’s primary mission is the destruction of enemy forces on the far side of the obstacle to prevent the enemy from placing direct fires on the breach lanes.

d. **Mass.** The support force achieves mass by fixing and isolating enemy forces on the far side of the obstacle. The breach force achieves mass by planning 50% redundancy of breach assets, creating one vehicle lane per each assaulting company-sized element, and creating two lanes separated by 800 to 1000 meters (terrain dependent) to pass the task force. The assault force achieves mass by projecting a 3:1 combat power ratio at the point of penetration (typically one isolated enemy platoon in an enemy company-sized defense for a task force breach).

e. **Synchronization.** Synchronization of all combined arms elements to successfully achieve the breach fundamentals is essential. Commanders achieve synchronization through detailed reverse planning of offensive operations (from the objective back to the assembly area), by issuing clear subordinate unit instructions, planning effective C2, and ensuring their forces are well rehearsed. Detailed reverse planning is initiated during IPB and development of enemy SITEMP. The scheme of maneuver, engineer operations, fires, air defense, and actions at the obstacle are all based upon this common SITEMP. For example--

- Actions on the objective determine the size and composition of the assault force based upon desired 3:1 combat power ratio.
- The size of the assault force determines the number and location of breach lanes required.
- Lane requirements and disposition and composition of the obstacles determine the mobility asset requirement of the breach force.
- The enemy's ability to interfere with the breach force at the point of breach determines size and composition of the security element within the breach force.
- The enemy's ability to mass fires on the point of breach determines the amount of suppression required as well as the size and composition of the breach force.

TF reverse planning begins with actions on the objective and continues to its deployment from tactical assembly areas in order to identify all mobility requirements. Reverse planning should include enemy special munition capabilities and effects (Figure 12-7, page 12-28).

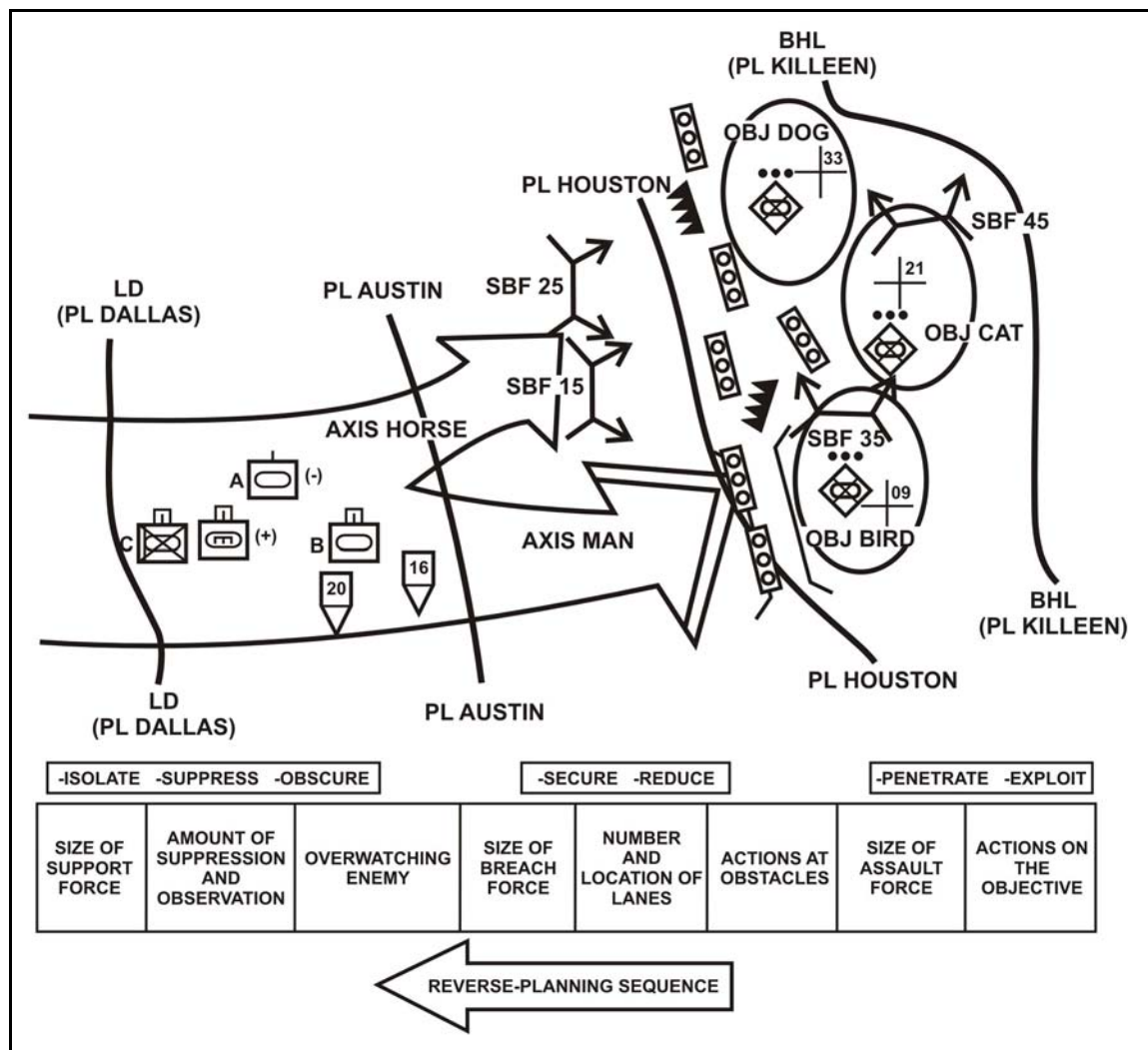


Figure 12-7. Reverse planning sequence.

**12-18. COMBINED ARMS BREACH DURING DELIBERATE OPERATIONS**

The following paragraphs discuss the detailed planning, preparation, and execution necessary in conducting a combined arms breach during deliberate operations.

a. **Planning.** Planning a breaching operation begins with the command and engineer estimates. The TF S2 templates the enemy’s order of battle, and the engineer assesses its engineer capabilities. Both the engineer and S2 doctrinally template the enemy’s tactical and protective obstacles. The staff develops COAs using the templates, and the engineer develops his scheme of engineer operations for each COA. After selecting a COA, the commander must carefully allocate available assets to the breach, assault, and support forces to ensure that they can accomplish their assigned tasks.

(1) Identifying the enemy’s vulnerability is important so that the force can mass direct and indirect fires and maneuver against that weakness. The TF isolates a portion of the enemy to achieve the desired combat ratio at the point of assault. It achieves mass by hitting the enemy from multiple directions and by narrowing attack zones to concentrate its force against a smaller defending element.

(2) When the attack requires breaching two or more complex obstacle systems, the commander must retain enough engineers and sufficient breaching assets to reduce subsequent obstacles. The commander must not commit all the engineers to breach the first obstacle system unless he is willing to risk his capability to breach follow-on obstacles. Depleted engineer forces need significantly more time to conduct follow-on breaches.

(3) In task organizing for a combined arms breach during a deliberate operation, the TF commander considers having a support force task-organized with weapons capable of a high volume of direct suppressive fires. The breach force disposition and composition is METT-TC dependent and determined by combat power required to secure the point of breach and the reduction assets required to create the lanes.

(4) The commander maneuvers his combat power to create sufficient suppression and security for the breach to be successful. Adequate suppression, obscuration, and security trigger the commitment of assault and breach forces. When the breaching site is free of direct fires, the commander deploys the breach force to create lanes through the obstacle. The commander must sense the progress of the breach so he can decisively commit the balance of the force through the obstacle to continue the mission.

(5) The breach and assault forces may require fires and smoke under their control in addition to that controlled by the support force. The support, breach, and assault forces place direct fires on enemy positions. This makes synchronization of direct and indirect fires extremely complex. Fire control must be planned in detail using simple and well-understood control measures carefully rehearsed.

(6) When a brigade conducts a combined arms breach during a deliberate operation or plans to conduct a passage of lines of a large force after a breach, breach plans must include detailed planning for the staging and movement of follow-on forces and equipment.

b. **Preparing.** The TF continues an aggressive intelligence collection plan using scout platoons, engineers, patrols, and aerial reconnaissance. The S2 and the TF engineer continually refine the template based on hard intelligence. The TF may adjust task organization as it uncovers more details of the defense and obstacle system. It also uses this information during the combined arms rehearsals.

(1) Continuous and aggressive intelligence-gathering operations update the enemy template as available. These changes are reflected as soon as possible in the rehearsal area. If updates become available after the last possible rehearsal, this data must be passed immediately to the affected force elements, especially the breach force.

(2) The TF meticulously plans, manages, and controls the rehearsals. The TF S3 allocates time for each unit to perform a combined arms TF rehearsal. When possible, the force rehearses the operation under the same conditions expected during the actual engagement, including battlefield obscuration, darkness, NBC posture, and inclement weather. The rehearsal site reflects the actual obstacle system in as much detail as possible. The force chooses terrain as similar as possible to that of the operational area and constructs a practice obstacle system based on OBSTINTEL. Rehearsals include a leader and key personnel walk-through as well as individual rehearsals by support, breach, and assault forces.

(3) When the force commander rehearses the breaching operation, he also rehearses several contingency plans. The contingencies should include possible enemy

counterattacks by counterattack forces and attack by enemy indirect fire systems (artillery, rockets, attack helicopters, and other air assets). Rehearsals also include enemy use of NBC munitions.

c. **Collecting Obstacle Intelligence.** The success of combined arms breaching during a deliberate operation depends heavily on the success of the ISR plan. The scheme of maneuver is based on known and templated intelligence of enemy positions and obstacles. NAIs are developed to confirm or deny the template. As confirmed intelligence reports come in, the template and ISR plan are updated and revised. The S2 develops the collection plan, with the scout platoon concentrating on confirming enemy locations. The engineers focus on gathering intelligence on obstacle orientation and composition as well as on the types of fortifications the TF may encounter. Confirmed intelligence is used to refine the task organization of support, breach, and assault forces and the scheme of maneuver.

d. **Executing.** The force crosses the LD organized to conduct the combined arms breach. If the TF encounters obstacles en route, it executes the breach with this organization. On arrival, the TF's scout platoon adjusts artillery fires on the enemy positions to cover deployment of the support force. The support force moves into position and establishes its SBF position. Breach and assault forces move into position and prepare to execute their tasks. The TF commander continues to incorporate last-minute information into his plan and makes final adjustments of positions and locations.

(1) The support force occupies its SBF position and immediately begins suppressing with a volley of fires. The support force FSE and TF FSO execute group targets planned on enemy positions. Mortar and artillery smoke are adjusted to obscure the breaching site from enemy target acquisition. The breach force begins movement once suppression and smoke are effective, based on clearly defined commitment criteria. Timing is critical since the high volume of suppressing fires and smoke can be sustained only for a short duration. SBF positions have interlocking sectors of fires and are positioned to ensure suppression of the enemy's positions.

(2) Once suppression and obscuration have built to effective levels, the breach force moves forward to the breaching site. The engineers create the lanes, while the combined-arms breach force provides for local security. As they finish the lanes, engineers create and send a digital overlay to assist the assault and following forces in maneuvering to the lanes. The assault force penetrates the objective after receiving the order from the TF commander. Due to the complexity of the breach, the command and control systems spread out to ensure synchronization. The TF S3 controls the multi-company team support force while the TF commander positions himself where he can best control the entire breaching operation.

e. **Continuing the Attack.** The obstacle system acts as a choke point and is dangerous even after the TF has overcome the defenses.

(1) The TF constructs additional lanes to speed the passage of follow-on forces. Next, it widens the lanes to allow two-lane traffic through the obstacles and constructs switch lanes to prevent blocking by disabled vehicles or artillery fires. Deliberate marking and fencing systems are installed, and military police establish the necessary traffic control. Eventually, rear-area engineer forces clear the obstacles and eliminate the choke point. After passage through the lanes, the maneuver force continues its mission.

(2) Both the breaching and follow-on force must be aware of the potential for the enemy to reseed breached obstacles with remotely delivered SCATMINES or other rapidly emplaced obstacles. The breaching commander may develop a response plan and position remaining mobility assets in the vicinity of the breach lane(s) to rebreach, repair, or improve lanes as necessary. In addition, the commander may develop a reaction plan for maneuver or other forces that encounter a reseeded portion of the obstacle while passing through the lane. The commander of the follow-on force, regardless of the reported status of the breach lanes he is about to pass through, should organize mobility assets forward in his formation that are prepared to rebreach, repair, or improve these lanes as necessary.

### **12-19. COMBINED ARMS BREACH DURING HASTY OPERATIONS**

Hasty operations are conducted when the enemy situation is vague and the commander may be required to execute the combined arms breach with his current task organization. Therefore, the TF commander must either task-organize his subordinate company teams with sufficient combat power to conduct company team level breaching operations or have a plan that allows for the flexible application of combat power necessary to execute breaching operations. When conducting offensive operations such as a movement to contact, while participating in an exploitation or pursuit, and when conducting passage of lines (forward or rearward) and movements through defiles, the TF commander must address breaching operations. The TF breach planning considerations and process discussed previously apply to combined arms breach planning during hasty operations as well. The only difference is the organizational echelon at which the breach is planned, prepared for, and executed.

a. **Planning.** Breach planning begins with IPB and engineer battlefield assessment (EBA) as part of the command and engineer estimate. The TF S2 and engineer jointly develop a SITEMP of the enemy disposition, most probable COA, and OBSTINTEL. The SITEMP is the focal point of force allocation and breach planning. If little is known about the situation, the S2 and the engineer identify areas where the enemy is likely to use obstacles or has used obstacles in recent operations. The engineer and S3 should also request information from higher headquarters on recent friendly use of obstacles in the area of operations.

(1) **TF Task Organization.** Subsequent to COA development, the commander and staff anticipate where units are most likely to encounter obstacles based on the scheme of maneuver and SITEMP. From this analysis, the commander refines his task organization, if necessary, in order to apply the combat power required to execute the templated breach. Additionally, the engineer recommends a task organization of engineer platoons and critical breaching equipment to create enough lanes for the breaching unit. He maintains a mobility reserve under his control that can create additional lanes for follow-on forces. This mobility reserve can also mass mobility assets if the TF must transition to a deliberate operation. The TF FSO designs his fire plan to provide priority of fires and smoke to company teams likely to conduct a breach. The ADO decentralizes the positioning of air defense weapons to provide local coverage of company teams during actions on contact and at obstacles. Above all, the commander task-organizes company teams for the mission first. He then modifies the task organization where necessary to

provide company teams with the additional forces needed to conduct independent breaching operations as part of the TF effort.

(2) **Company Team Task Organization.** A force plans for the hasty operation breach by appropriately task-organizing subordinate TFs or company teams. The subordinate commander develops the details necessary for success. In a TF hasty operation breach, the company team commander further task-organizes his force and designates specific support, breach, and assault forces. Since conducting the breach involves only committing the combat power within the company team, the team commander incurs the responsibility to develop plans that synchronize the breaching effort and achieve the breaching fundamentals (SOSRA). The assault force moves through the lanes, deploys, and continues the attack to destroy the defending enemy forces. Company team breach planning is deliberate. It requires the team commander to develop a team scheme of maneuver or an immediate action drill that maneuvers support, breach, and assault forces (platoons) to apply SOSRA breaching fundamentals on obstacle contact (Table 12-1, page 12-26). If the enemy situation is unknown, then support, breach, and assault forces execute their missions on order as part of an action-on-contact drill.

b. **Preparing.** Preparation for the breach focuses on subordinate TF or company-level rehearsals. The success of the TF breach depends on the ability of company teams to react quickly to enemy or obstacle contact. The TF assists company teams in preparing for the mission by constructing and managing rehearsal sites that team commanders can use to drill their units on actions on contact and at obstacles. The TF engineer ensures that engineer platoons and breaching equipment link up with maneuver units early to maximize the opportunity to rehearse as a combined arms team. Company team commanders include their complete task organization in all orders, briefbacks, rehearsals, and precombat inspections (PCIs). The TF minimizes the time spent on TF rehearsals and briefbacks to allow company team commanders more time with their units. During TF rehearsals, discussion centers on how critical breaching assets will shift to support company team breaching operations and on the transition to a deliberate breach.

c. **Collecting Obstacle Intelligence.** The ability of the force to collect timely and accurate OBSTINTEL, both before and during the attack, has tremendous impact on the success of the breach. A TF commander elects to breach when the situation is vague or when intelligence indicates that a company team can overwhelm enemy obstacles and fires. The breach will fail if the company team does not have enough combat power to suppress the enemy's fires or enough breaching equipment to reduce the obstacles. Therefore, the size of the enemy force and the type of obstacle are priority information requirements for reconnaissance.

(1) Engineer forces are attached to the scout platoon to gather detailed intelligence on obstacle locations, composition, and orientation. Like any specialized collection asset, the engineer squad works for the scout platoon leader and is integrated into the total TF collection plan. The S2 and engineer provide the scout platoon with specific NAIs for the engineer squad to reconnoiter. The squad sends its reports on the scout platoon net.

(2) OBSTINTEL collection is particularly difficult when the breach is part of a movement to contact. Although engineers may be attached to the scout platoon, their ability to close with and gather detailed OBSTINTEL in time for the advance guard or main body to react is limited. Furthermore, organizing for a breach in a movement to contact quickly consumes the number of engineers available for the reconnaissance

effort. The commander must weigh the effects that dedicating an engineer squad to reconnaissance will have on his organization and its ability to transition to a deliberate breach against the effect this will have on other engineer missions.

(3) A breaching element must continue to gather intelligence and develop the situation during the attack. Early detection of obstacles is essential for maintaining momentum and for the timely commitment of engineers.

d. **Executing.** Execution of the breach is the responsibility of the subordinate commander. The company team commander applies the SOSRA breaching fundamentals by synchronizing the efforts of his vehicles, infantry, indirect fires, and engineer assets. When breaching during a hasty operation, the company team commander achieves synchronization by executing well-rehearsed actions at obstacles. Platoons execute their support, breach, and assault missions as part of the scheme of maneuver when the company team's breach is part of the TF plan of attack.

(1) The TF commander has two roles in a breach during hasty operations. Both are crucial to company team breaching efforts. First, he ensures that the company team receives the appropriate level of combat power and engineer assets, as well as the planned priority of indirect fires and smoke, but he still allows the company team commander to fight his battle. Second, the commander ensures that the additional combat power and mobility assets required to transition to a TF deliberate operation breach are positioned to assume the responsibilities of the breach force. The commander closely monitors the company team breaching effort so he can decisively commit his force to the breach, if necessary, with minimal loss of momentum.

(2) During hasty operations, such as movement to contact or pursuit, the breach is normally conducted when no obstacle bypasses are found. The breach maintains the momentum of the attack by denying the enemy time to mass forces to cover the obstacles. Proper integration of engineers and breaching assets into TF and company team formations (positioned forward and organized in a manner that allows efficient introduction of the required breaching assets) is critical to the success of the breach. Because the exact location and nature of enemy forces and obstacles are unknown, engineers and breaching assets must be distributed carefully to allow the commander to move securely while maintaining forward-deployed breach and assault forces.

(3) A TF needs at least one lane for each assaulting company team (vehicle-mounted) and one footpath per assaulting platoon (dismounted). The distance between lanes is inherently tied to the scheme of maneuver, the complexity of the terrain, and the composition and disposition of the overwatching force. General guidelines for the distance between lanes are 800 to 1000 meters between vehicle lanes (based on the complexity of the terrain and the probability of enemy SCATMINE employment) and up to 100 meters between footpaths (normally based on the ability of the support force to achieve suppressive fires). Constructing and marking each vehicle lane requires an engineer squad reinforced with breaching equipment, such as MICLICs, task-organized to the company team executing the breach. A third squad is required to provide depth and flexibility to the TF mobility effort. A main effort TF, therefore, integrates an engineer platoon throughout its maneuver formations when task-organizing for breaching operations during hasty operations. Supporting a TF breaching operation with fewer engineers decreases the probability of success.



(4) Engineer integration into TF formations must provide lead company teams with immediate breaching capability and maintain the flexibility to shift assets to where they are needed. Engineer platoons reinforced with special breaching assets from the engineer company are integrated directly into the combat formations of the lead company teams. An engineer squad is maintained under TF control as a mobility reserve. This squad maneuvers at the center of the TF formation or as an echelon of the company team that is most likely to need engineer support. The engineer platoon leader moves with the TF, positioning himself where he can best control assets under his control and track the efforts of his detached platoons.

(5) The tactical situation often requires a TF to modify its combat formation. Maneuver units train constantly to accomplish this quickly and efficiently; field SOPs outline required actions in great detail. Engineers integrating into the formation must adjust rapidly to maintain engineer and breaching assets with lead company teams. Transition from a vee formation to a column formation and vice versa is not complicated; engineers remain integrated in lead company team formations. Transitioning from a wedge to a column, however, can be more difficult. Ideally, a transition to a column formation should result in engineers supporting the first two company teams in the column.

(6) Regardless of which formation the TF uses, the TF combat trains usually travel just in front of or just behind the trail company team. Combat trains usually transport critical engineer Class V materials, such as an emergency resupply of demolitions and MICLIC reloads. The commander, engineer, and S4 anticipate when these assets might be used and develop a plan for rapidly moving them forward.

(7) Integrating engineers into the force continues at the company level. The company team commander determines which combat formation is appropriate for each phase of the attack. The engineer platoon leader must fully understand the company team scheme of maneuver and which formations it will use, and he must anticipate changes in formation. Close coordination between the engineer and maneuver company team commanders is vital to ensure support is at the right place at the right time.

(8) An engineer platoon normally maneuvers with three M113s and one or two AVLMs. The carriers do not tow trailers except for MICLIC launchers, if so equipped. AVLBs and ACEs augmenting the platoon move behind the company team. They remain one terrain feature back, guiding on the trail element, and are always within support range. A good technique is to maneuver AVLBs and ACEs with the company team trains under the control of the engineer platoon leader or the team first sergeant.

(9) For definitive information on how HSS is provided for breaching operations, see FM 4-02.4. In addition, plans must be in place for clearing casualties off the battlefield since increased numbers of casualties should be anticipated during a breach operation. Each company team requires an ambulance for casualty evacuation.

## **Section VII. TACTICAL ROAD MARCH**

The battalion task force conducts two kinds of movement: administrative and tactical. An *administrative movement* considers tactical implications, but its primary emphasis is on expediting movement and conserving time and energy. Administrative movements are based on the assumption that contact with the enemy during or shortly after the move is unlikely. A *tactical road march* is a rapid movement used to relocate units in a combat

zone in order to prepare for combat operations. Although hostile contact is not anticipated, the unit must maintain security measures and be prepared to react to enemy contact. At battalion task force level and higher, the S3 is responsible for planning tactical road marches. The S4 has primary staff responsibility for planning administrative movements, but he coordinates his plans with all other staff members.

## 12-20. MARCH ELEMENTS

The elements of a road march include the march column, serial, and march unit.

a. **March Column.** A march column includes all elements using the same route for a single movement under control of a single commander. A battalion task force may march over multiple routes to reduce closing time. A large march column may be composed of a number of subdivisions, each under the control of a subordinate commander.

b. **Serial.** A serial is a subdivision of the march column. It consists of elements of a march column moving from one area over the same route at the same time. All the elements move to the same area and are grouped under a serial commander. A serial may be divided into two or more march units.

c. **March Unit.** A march unit is the smallest subdivision of a march column and normally consists of no more than 25 vehicles using the same route for a single movement and under the control of a single commander. It is normally a squad, section, platoon, or company team. It moves and halts under control of a single commander using voice and visual signals. It uses radio only when it can use no other means of communication.

(1) ***Prior to Executing the Movement.*** Before starting a march, each march unit of a serial reconnoiters its route to the start point and determines the exact time to reach it. The movement order states the time the serial will arrive at and clear its start point. The serial commander then determines and announces the times for march units of his serial to arrive at and clear the start point. Arrival time at the start point is critical. Each march unit must arrive at and clear the start point on time; otherwise, movement of other elements may be delayed.

(2) ***During the Movement.*** During movement, march units move at the constant speed designated in the order, maintaining proper interval and column gap. Elements in a column of any length may simultaneously encounter many different types of routes and obstacles, resulting in different parts of the column moving at different speeds at the same time. This can produce an undesirable accordion-like action or whip effect. The movement order gives march speed, rate of march, and maximum catch-up speed. March units report crossing each control point as directed by the march order. They maintain air and ground security during the move.

## 12-21. MARCH COLUMN ORGANIZATION

March columns, regardless of size, are composed of four elements: reconnaissance party, quartering party, main body, and trail party. March columns are organized to maintain unit integrity and to maintain a task organization consistent with mission requirements. An element or a group of elements in a march column receives a numerical or alphabetical designation for planning, scheduling, and controlling.

a. **Reconnaissance Party.** Engineer and other CS assets may augment the reconnaissance party. It performs route reconnaissance to determine travel time, capacities of underpasses and bridges, and locations of ferries and fords; it identifies critical points, including choke points and obstacles. Route reconnaissance confirms and supplements data from map studies, higher headquarters, and air reconnaissance. Instructions to the reconnaissance party should state the nature and extent of information required and the time and place the report is to be submitted.

b. **Quarterming Party.** The quarterming party normally consists of representatives from company teams or attached units. It reconnoiters the new area, marking unit positions and guiding the march column elements into these new positions as they arrive. (See Section II for additional information on quarterming party responsibilities when occupying an assembly area.)

c. **Main Body.** March units of the main body consist of individual maneuver units with their trains, TF mortars, any attachments, the TF CP, and the TF trains. POL vehicles required for refueling during nontactical marches may move ahead of schedule to establish a service station refuel point.

d. **Trail Party.** The trail party normally consists of elements of the TF maintenance platoon and medical support. The trail party is the last march unit in a TF serial, consisting of elements of the maintenance platoon led by the BMO. The function of the trail party is to recover disabled vehicles. If at all possible, some security element such as an additional mechanized infantry platoon should accompany the trail party for protection.

(1) **Mechanical Failures.** If a vehicle cannot be repaired or towed, it is moved off the road and into a secure area. The drivers and crewmembers, supplied with sufficient food and water, remain with the vehicle. The BMO reports the location and reason for leaving the vehicle behind to the battalion task force S4.

(2) **Recovery.** Once the trail party completes the road march, maintenance priority becomes the recovery of disabled vehicles. A tactical road march is not complete until all march units and vehicles arrive at the destination.

## 12-22. TECHNIQUES

The purpose of conducting a road march is to relocate rapidly, not to gain contact with the enemy. Road marches are performed at fixed speeds and during timed intervals. The road march must be organized to meet mission requirements and provide organizational control. The three basic types of techniques are closed column, open column, and infiltration.

a. **Closed Column.** Closed column is normally used during limited visibility or on poorly marked or congested roads. It is characterized by vehicle intervals of 25 to 50 meters. This technique takes maximum advantage of the traffic capacity of the route but provides little dispersion of vehicles.

b. **Open Column.** In open column, the distance between vehicles is increased for greater dispersion. It is characterized by vehicle distance of approximately 50 to 200 meters; however, the factors of METT-TC determine actual dispersion. Open column is normally used during daylight but may be used at night with blackout lights or thermal vision equipment. Open column is normally used on well marked routes with good visibility.

c. **Infiltration.** Infiltration has no defined structure. During a move by infiltration, vehicles are dispatched individually, in small groups, or at irregular intervals at a rate that keeps the traffic density down and prevents undue vehicle massing. Infiltration provides the best possible passive defense against enemy observation and attack. It is suited for tactical marches when sufficient time and road space are available and when maximum security, deception, and dispersion are desired or directed.

## 12-23. PLANNING CONSIDERATIONS

Road marches require extensive planning. Commanders and staff use the military decision-making process to determine how best to execute a move from one point to another. (Refer to FM 55-10 for a detailed discussion of movement planning considerations, terms, and movement time computation.)

a. **Factors for Consideration.** The following factors are considered when planning a road march:

- Requirements for the movement.
- Organic and nonorganic movement capabilities.
- Unit movement priorities.
- Enemy situation and capabilities, terrain conditions, and weather.
- Organization of the TF.
- Security measures before and during the movement and at the destination.
- Assembly of the march units.
- Actions at the destination.

b. **Sequence of Road March Planning.** When preparing for a tactical road march, the battalion task force uses the following sequence of march planning, as time permits.

(1) Prepare and issue an oral warning order as early as possible to allow subordinates time to prepare for the march.

(2) Analyze routes designated by higher headquarters and specify organization of the march serial.

(3) Prepare and issue the march order.

(4) Prepare a detailed movement plan and assembly area plan.

(5) Organize and dispatch reconnaissance and quartering parties as required.

## 12-24. MOVEMENT ORDER

The movement order format is the same for administrative and tactical movements, IAW FM 101-5. The movement order is prepared as an annex to an operation order, as a separate operation order, or as a FRAGO.

## 12-25. CONTROL MEASURES

The commander uses the control measures discussed in the following paragraphs to assist in controlling the task force during the road march.

a. **Graphics.** Road march graphics should include, at a minimum, the SP, RP, and route.

(1) **Strip Map.** The TF strip map should depict the following (Figure 12-8, page 12-38).

- Start point.
- Release point.

- Scheduled halts.
- Convoy routes.
- Major cities and towns.
- Critical points and checkpoints.
- Distance between CPs.
- North orientation.

(a) A start point is a well-defined point on a route at which movement of vehicles falls under the control of the movement commander. It is at this point that the column is formed by the successive passing, at an appointed time, of each of the elements comprising the column. The SP should be an easily recognizable point on the map or on the ground. It should be far enough from the assembly area to allow units to be organized and moving at the prescribed speed and interval when the SP is reached.

(b) A release point is a well-defined point on a route at which the elements comprising a column return to the authority of their respective commanders. At the RP, each element continues its movement toward its own destination. Multiple movement routes from the RP enable units to disperse rapidly and navigate to their assembly areas or areas of operation.

(c) Scheduled halts may be needed to provide rest, mess, refuel on the move sites, and maintenance. Dining and refueling halts should coincide, if possible.

(d) Critical points or checkpoints on a route are places used for information references, places where obstructions or interference with movement might occur, or places where timing may be a critical factor. They are also used as a control measure for control and maintenance of the schedule. Guides or signs may be used at designated critical points and or checkpoints to ensure the smooth flow of movement.

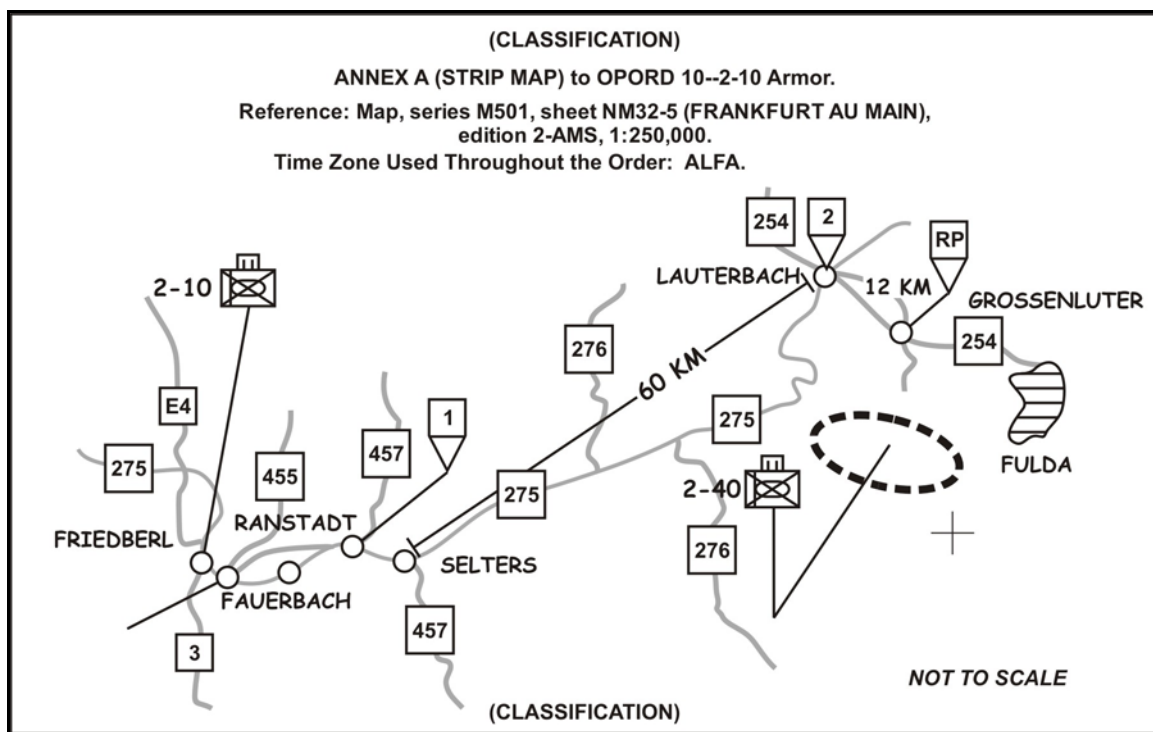


Figure 12-8. Example battalion task force strip map.

(2) **Digital Overlays.** In units equipped with FBCB2, digital overlays enhance mounted navigation. They display waypoints and other information concerning unit locations along the route of march and facilitate maintaining a COP.

b. **Communications.** Messengers and visual signals are the preferred means of communication during road marches. Because the enemy has radio direction-finding equipment, the TF uses radio only in emergencies and when it can use no other means of communication. The TF can also use road guides to pass messages from one march unit to a following march unit. Because of the need to stay off the radio, road guides are important in controlling the speed of march units and the interval between them.

c. **Traffic Control.** The headquarters controlling the march may post road guides and traffic signs at designated traffic control points. At critical points, guides assist in creating a smooth flow of traffic along the march route. Military police, members of the task force scout platoon, or designated elements from the quartering party may serve as guides. They should have equipment or markers that will allow march elements to identify them in darkness or other limited visibility conditions. There is normally an RP for every echelon of command conducting the road march. Traffic problems may arise if actions at each of these points are not well rehearsed.

## 12-26. SECURITY

During the movement, march units maintain security through observation, weapons orientation, dispersion, and camouflage. Commanders assign sectors of observation to their personnel to maintain 360-degree observation. Main weapons are oriented on specific sectors throughout the column. The lead elements cover the front, following elements cover alternate flanks, and the trail element covers the rear.

a. **Halts.** While taking part in a road march, the march elements must be prepared to conduct both scheduled and unscheduled halts.

(1) **Scheduled Halts.** Scheduled halts are planned along the march route for maintenance and rest or to follow higher level movement orders. At scheduled halts, vehicles and soldiers move to the side of the road while maintaining march dispersion. Local security is set up immediately, and drivers perform during-operations maintenance checks. The unit is ready to move at a moment's notice.

(2) **Unscheduled Halts.** Unscheduled halts and actions may be caused by unforeseen developments such as obstacles, traffic congestion, or equipment failure. If a halt is necessary, the march column's first priority is to establish security.

b. **Air Defense.** Planning for air defense and implementing all forms of air defense security measures are imperative to minimize the TF's vulnerability to enemy air attack. The TF commander must integrate his fire plans effectively with the attached air defense artillery assets. Furthermore, he must ensure the TF plans and uses all passive and active air defense measures that can be implemented at company level. Each vehicle in a motor march has an air guard to provide air security. Specific vehicles may be designated as air guard vehicles performing air rather than ground observation.

c. **Obstacles.** The TF should bypass obstacles reported by the scout platoon if possible. If it cannot bypass obstacles, the lead march unit goes into a defense to cover and overwatch and breaches the obstacle, working with engineers if available. As the lead march unit breaches the obstacles, the other march units move at decreased speed or move off the road and monitor the TF command net.

d. **Enemy Indirect Fire.** Should the TF come under attack by enemy indirect fire during the road march, the unit in contact continues to move. The remainder of the TF attempts to bypass the impact area.

e. **Enemy Air Assault.** Should the TF be attacked by hostile aircraft during the march, the march unit under attack moves off the road into a quick defensive posture and immediately engages the aircraft with all available automatic weapons. The rest of the TF moves to covered and concealed areas until the engagement ends.

f. **Disabled Vehicles.** Disabled vehicles must not obstruct traffic. They are moved off the road and their status reported immediately. Security is established, and guides are posted to direct traffic. If the operator repairs the vehicle, it rejoins the rear of the column. If the operator cannot repair the vehicle, trail party maintenance elements pick it up.

g. **Restrictions.** Restrictions are points along the route of march where movement may be hindered or obstructed. These points can include bridges, intersections, ferries, and bypasses. The march planner should stagger start times or adjust speeds to compensate for restrictions, or he should plan to halt the column en route until the restriction is over.

h. **Limited Visibility.** Units must be able to operate routinely under limited visibility conditions caused by darkness, smoke, dust, fog, heavy rain, or heavy snow. Limited visibility decreases the speed of movement and increases the difficulty in navigating, recognizing checkpoints, and maintaining proper interval between units. To overcome command and control problems caused by limited visibility, commanders may position themselves just behind lead elements. More restrictive control measures, such as additional checkpoints, phase lines, and use of a single route, may become necessary.

### **Section VIII. ASSEMBLY AREA OPERATIONS**

An assembly area is a location where a force prepares or regroups for further action. While in assembly areas, units execute the organization, maintenance, resupply, and personnel actions necessary to maintain the combat power of the force. Designation and occupation of an assembly area may be directed by a higher headquarters or by the unit commander during relief or withdrawal operations or unit movements.

#### **12-27. ASSEMBLY AREAS**

Assembly areas are areas occupied by forces where enemy contact is likely and commitment of the unit directly from the assembly area to combat is possible or anticipated. Examples of units likely to be in assembly areas include units designated as tactical reserves, units completing a rearward passage of lines, units preparing to move forward to execute a forward passage of lines followed by offensive operations, units performing tactical movements, and units conducting reconstitution. Assembly areas should provide--

- Concealment from air and ground observation.
- Cover from direct fire.
- Terrain masking of electromagnetic signal signature.
- Sufficient area for the dispersion of subunits and their vehicles consistent with the enemy and friendly tactical situation.
- Areas for unit trains, maintenance operations, and C2 facilities.

- Suitable entrances, exits, and internal routes. (Optimally, at least one all-weather paved surface road transits the assembly area and connects to the MSR in use.)
- Terrain allowing the observation of ground and air avenues of approach into the assembly area.
- Good drainage and soil conditions that support unit vehicle movement.

## 12-28. ORGANIZATION

Battalion task force tactical assembly areas may be organized using one of three methods.

a. **Method 1.** The TF may occupy a portion of the perimeter of a brigade assembly areas. It does so by arraying company teams, generally on a line oriented on avenues of approach into the assembly area. Leftmost and rightmost units tie in their fires and areas of observation with adjacent units of other battalion task forces. Depending on the tactical situation and width of the area assigned to it, the TF may maintain a reserve. TF trains are located to the rear of the company teams. The TF mortar platoon and the main CP are located centrally in the assembly area where they can communicate and support units by fire. The scout platoon screens along the most likely or most dangerous avenue of approach.

b. **Method 2.** The TF may assign sectors to subordinate company teams and require them to tie in their fires and observation with each other. The main CP, trains, and mortar platoon are located near the center of the assembly area. Ideally, company team sectors are assigned to balance the task organization against the appropriate enemy avenue of approach. The scout platoon occupies observation posts at key points around the entire perimeter of the TF or screens along the most dangerous or likely avenue of approach. This method configures the TF in a perimeter defense with company teams oriented outward. This is the most common organization of TF assembly areas.

c. **Method 3.** The TF may assign separate individual assembly areas to subordinate company teams, which establish their own 360-degree security. Areas between company teams are secured through surveillance and patrolling. The main CP, trains, and heavy mortar platoon establish positions central to outlying company teams. If the TF is dispersed over a large area, SHORAD assets (if available) may need to collocate with company teams for adequate air defense.

**NOTE:** The battalion task force usually establishes echelons of trains by locating the field trains with the FSB in the BSA and positioning the combat trains centrally within the assembly area. However, when the parent unit is located in the rear area and not designated as a tactical reserve, the brigade does not form a BSA. In this case, the TF establishes unit trains in the center of its assembly area.

## 12-29. QUARTERING PARTY

A quartering party is a group of unit representatives dispatched to a probable new site of operations to secure, reconnoiter, and organize an area before the main body's arrival and occupation. Unit SOPs establish the exact composition of the quartering party and its transportation, security, communications equipment, and specific duties. Quartering



parties typically reconnoiter and confirm the route and tentative locations previously selected from map reconnaissance. Quarters parties also serve as a liaison between their parent headquarters and the quarters party of their higher headquarters to change unit locations in the assembly area based on the results of their reconnaissance.

a. **Planning Considerations.** The S2 routinely receives intelligence information from brigade headquarters throughout the TF's deployment and operations. From this information, the S2 determines the characteristics and likelihood of the air and ground threat to the quarters party during its movement to and occupation of the assembly area. This information assists the TF staff and the quarters party OIC in determining the mode of transportation and security required and the desirability of maintaining the quarters party in the assembly area during the movement of the rest of the TF.

(1) The quarters party typically moves to the new assembly area by infiltration. For security, it may move with another subunit quarters party, depending on the likelihood of enemy contact. In this case, it may be necessary to move as a march unit of a road march if the number of vehicles exceeds local SOP restrictions on vehicular infiltration. Ideally, the quarters party moves over the routes to be used by the TF and executes a route reconnaissance and time-distance check.

(2) The quarters party typically includes an OIC or NCOIC and representatives from the TF main CP, TF trains, and the TF's subunits. The S3 air, HHC XO, S1, S3 SGM, and CSM are potential quarters party leaders.

(3) Composition of maneuver company team quarters parties is usually determined by the company team commander but may be specified by the battalion task force commander. HHC representatives typically include NCOs from key support sections such as communications, maintenance, or supply. Representatives from the mortar platoon and the scout platoon are also represented in the quarters party.

(4) The main CP quarters party identifies potential CP locations based on tactical requirements such as cover and concealment and the line-of-sight signal requirements of FM radios.

(5) An alternative technique is to send the operation's M577 with the quarters party to establish C2 while the TF main body is moving. If planning time is short, key members of the staff can move with the quarters party. This enables the staff to begin detailed planning immediately upon arrival in the assembly area. This technique also facilitates transitions to new missions by pre-positioning key staff members so planning can occur concurrently with the movement of the main body.

(6) When the TF employs echeloned trains, a combat trains representative accompanies the quarters party, and another quarters party is formed for the field trains. Unit SOP establishes the composition, deployment, and actions of the field trains quarters party.

(7) If the TF moves and occupies its assembly area as part of a brigade, the brigade makes all coordinations for fire support. If the TF moves and occupies the assembly area without FS planning by its higher headquarters, it conducts its own FS coordination.

(8) During its planning, the staff must determine combat service support requirements for the quarters party. The estimate of necessary supplies and equipment must cover the entire quarters party, including accompanying staff section representatives and CS and CSS assets.

(9) The quartering party may move under radio listening silence or other emission restrictive posture, especially during movement to tactical assembly areas.

b. **Preparation.** The quartering party OIC or NCOIC plans his operations through coordination with TF staff officers.

(1) **Intelligence.** The S2 ensures the quartering party OIC and or NCOIC is aware of the current enemy situation, probable enemy courses of action, the weather forecast, and the terrain and vegetation likely en route to and in the new assembly area.

(2) **Maneuver.** The OIC or NCOIC coordinates with the S3 to determine the mission of the quartering party, whether or not the quartering party is to remain in the assembly area and await the remainder of the TF, and the route and movement restrictions to be used by the quartering party. The OIC or NCOIC ensures subordinate unit quartering parties know where and when the TF quartering party will be located in the assembly area.

(3) **Engineer Support.** The TF engineer coordinates with the quartering party OIC or NCOIC to determine whether sending engineer personnel with the quartering party for the reconnaissance and evaluation of routes, bridges, and cross-country mobility is recommended or required.

(4) **Air Defense.** Air defense units may move with the quartering party en route to and in the new tactical assembly area. If air defense assets move with the quartering party, the air defense unit leader ensures he knows both the current and projected future weapons control status (WCS) and air defense warning.

(5) **Command and Control.** After the OIC or NCOIC has completed his planning, he assembles the members of the quartering party at a time and place of his choosing to brief them. This briefing follows the standard five-paragraph field order format. Emphasis is on actions at halts and critical areas, actions of the quartering party in the assembly area, contingency plans, and procedures to request and receive CS and CSS. He should cover in detail medical evacuation procedures, actions on contact, and actions to take if separated from the quartering party.

c. **Execution.** The following considerations apply to quartering party execution:

(1) **Maneuver.** The quartering party navigates by infiltration to the assembly area, generally along one route. If the quartering party moves along a route to be used by the main body and the main body has not yet sent a reconnaissance party forward, the quartering party conducts a route reconnaissance during its movement. The quartering party may also execute a time-distance check of the designated route. Driving the march speed of the TF's main body march units, the OIC or NCOIC notes the time and actual vehicle odometer distances between the CPs along the route. He reports these times and distances to the main CP after moving through the RP.

(a) Upon arrival in the assembly area, the quartering party navigates to assigned positions and executes the required reconnaissance. The quartering party also has the following responsibilities at the assembly area:

- Determines locations for individual vehicles.
- Identifies unit left and right limits of fire, records this information, and sends updates to the unit's commander.
- Determines the location for the main CP and records it.
- Verifies subordinate unit locations and sectors of fire to ensure there are no gaps in coverage.

- Ensures necessary routes are cleared.
- Transmits changes or updates to the main CP to alert the main body to changes in the route and assembly area.

(b) If reconnaissance of proposed locations reveals the area is unsuitable for occupation, the quartering party OIC or NCOIC attempts to adjust unit locations in the area assigned. If such adjustments do not correct the problem, he immediately notifies the S3 or commander.

(c) If an element of the main CP has accompanied the quartering party, it moves to the location reconnoitered by its representative and establishes forward C2 for the TF. If air defense assets have accompanied the quartering party, they occupy advantageous firing positions oriented on air avenues of approach. Representatives organize their respective areas by selecting and marking positions for vehicles and support facilities. If designated, guides move on order to preselected checkpoints or RPs to await main body march unit elements.

(d) If the TF quartering party is not going to remain in the assembly area, it does not depart the assembly area until all subordinate unit quartering parties have reported. The unit quartering parties should provide the results of their reconnaissance and identify requested changes to their tentative locations.

(e) Each commander or unit leader must decide if and when guides are required to assist in occupying the assembly area. Normally, the use of guides is planned for occupations during periods of limited visibility.

(2) **Engineer Support.** In some cases, mobility support is required to repair or replace damaged bridging or roadways where no feasible bypass is available. Engineer units supporting the TF may accompany the quartering party to execute mobility operations.

(3) **Combat Service Support.** CSS assets may accompany the quartering party. CSS elements generally conduct resupply and maintenance operations for the quartering party at scheduled halts or in the new assembly area.

### 12-30. OCCUPATION

Units position themselves in assembly areas in accordance with their parent unit's tentative plan. Quartering parties typically guide units into position. The units accomplish occupation smoothly from the march without halting or bunching of units at the RP. Subordinate units normally establish routes and separate SPs and RPs for march elements that extend from the march column's route or RP toward the march units' assembly area positions. This technique clears the route quickly, maintains march unit C2, and prevents bunching of units at the march column RP. The TF begins movement to the assembly area with an updated movement route, specific coordinates for vehicle locations, and a confirmed defensive scheme for occupation of the assembly area. This enables the TF to transition quickly from the road march into the actual occupation while maintaining overall security for the main body.

a. **Intelligence.** The S2 assists in planning the assembly area occupation by identifying enemy avenues of air and ground approach into the new assembly area and the degree and type of rear area threat to the TF in its new location. The S2 also identifies and disseminates the security requirements for the TF and begins preparing the R&S plan for the assembly area. In coordination with the S3, the S2 makes preliminary plans for

reconnaissance and surveillance tasks to be assigned to subunits in the TF, including the scout platoon.

b. **Maneuver.** The commander or S3 chooses a method for occupation (whole TF assembly area or separate subunit assembly areas) and tentative subunit locations based on METT-TC. He then considers selecting tentative assembly area locations. To operate effectively in the assembly area, selected subunits may have specific positioning requirements, such as being near mess units, near water for decontamination, or on hardstand for DS maintenance. Based on METT-TC, the commander or S3 develops contingency plans that address the possibility of significant enemy contact in the assembly area. Time available and the likelihood of enemy contact determines the level of detail in contingency plans. These plans typically include FS plans and alternate assembly areas or rally points in case the TF is forced out of its initial assembly area.

c. **Fire Support.** FS requirements are coordinated with units already positioned near the new assembly area. Support shortfalls between requirements and availability are coordinated with either higher or adjacent units. FS planning includes support for TF contingency plans in case of enemy ground contact.

d. **Engineer Support.** The type and extent of engineer support required in the assembly area depends on the anticipated length of stay, type and degree of enemy threat, terrain in the assembly area, and the follow-on mission of the TF. The TF is responsible for all mobility and survivability tasks in the assembly area.

e. **Air Defense.** Air defense planning for the tactical assembly area focuses on the selection of SHORAD firing positions that will allow the engagement of enemy aerial platforms along identified air avenues of approach. Depending on the commander's stated priority of protection, assets available, and task organization, air defense units may locate with supported TF subunits or in separate locations under TF control.

f. **Combat Service Support.** The S4 recommends CSS positioning and typically positions the combat trains near the TF main CP to allow wire communications between them. HHC support elements position themselves in relation to the TF TOC and the mortar platoon.

g. **Command and Control.** The XO and S2 determine tentative locations for TF C2 facilities from map reconnaissance based on METT-TC. The overriding consideration for selecting these locations is the ability of the various CPs to communicate higher, lower, and laterally. Establishing the main CP in the new assembly area should occur early in the occupation so subunit CPs can locate based on their requirement to communicate with the main CP.

### 12-31. ACTIONS IN THE ASSEMBLY AREA

The TF focuses all actions in the assembly area on preparing for future operations to include resupply, personnel replacement, maintenance, reorganization, rest, and the planning of future operations.

a. The TF initiates administrative personnel actions in the assembly area if time permits.

b. Maintenance activities concentrate on deadline faults and those degrading the unit's ability to shoot, move, and communicate. The unit pays special attention to those maintenance tasks that are too time-consuming or difficult to perform during combat operations.

c. The units conducts resupply actions in the assembly area to replenish items used in previous operations, to assemble stocks for future operations, and to replace damaged and contaminated supplies as required. Refueling during the move to the assembly area is easier and faster than refueling after arrival in the assembly area.

d. The unit conducts planning and preparation for future operations concurrently with maintenance and administrative activities.

e. The unit may require training if issued new or modified equipment while in the assembly area. Small unit training may be necessary if large numbers of replacement personnel are introduced into the unit, especially if significant numbers of key leaders are replaced.

### 12-32. SECURITY

Security comprises measures taken by a military unit to protect itself against surprise, observation, detection, interference, espionage, sabotage, or annoyance that may impair its effectiveness. Security is essential to the protection and conservation of combat power. It may be achieved by establishing and maintaining protective measures or through deception operations designed to confuse and dissipate enemy attempts to interfere with the force being secured. Effective security prevents the enemy from gaining an unexpected advantage over friendly forces.

a. **Security in the Assembly Area.** Forces in tactical assembly areas are provided a degree of security by their separation from the line of contact and by the presence of other units between them and the enemy. In corps and division rear areas, security is provided through rear battle contingency plans. If the assembly area is well forward, security is provided by proximity to other combat or CS units. In keeping with their mission and the tactical situation, units in tactical assembly areas employ active security measures. These measures include reconnaissance and patrolling, visual and electronic surveillance of ground and air avenues of approach, and establishment of OPs. Regardless of the security that may be provided by other units or agencies, the commander takes whatever actions or precautions he deems necessary to secure his command.

b. **Positioning of Company Teams.** The TF positions company teams with respect to avenues of approach and access routes into the assembly area. Company teams tie in their fires, observation, and patrolling with one another. This is fairly simple for the TF because the company teams typically occupy a portion of a TF perimeter and are immediately adjacent to another company team. Company teams exchange sector sketches, fire plans, and patrolling plans with adjacent units.

c. **Positioning of the Scout Platoon.** The scout platoon may be positioned in one of three ways to enhance the security of the TF:

- It can form a screen astride the most likely or dangerous avenue of approach.
- It can establish several temporary OPs and conduct patrols between them to provide a thin screen line that surrounds the entire assembly area.
- It can be positioned to observe an area that cannot be seen by other units in the assembly area.

Company teams may also be repositioned to observe these areas. GSRs allocated from brigade are either retained under TF control or, more typically, attached to the scout platoon.

d. **OPSEC.** The TF practices the usual OPSEC measures to enhance the security of the unit while in the assembly area. OPSEC includes active and passive measures that attempt to deny the enemy information about friendly forces. Units in the TF practice noise and light discipline, employ effective camouflage, and eliminate or reduce radio traffic. Other electronic transmissions such as jammers and radar are also restricted. Units may construct and employ uni-directional antennas to reduce electronic signatures.

e. **Noncombatants.** Movement of civilians and refugees near assembly areas is strictly controlled to prevent enemy sympathizers or covert agents from obtaining information about the TF. Units may remove unit markings and uniform patches in some cases to retain unit anonymity. When possible, the unit conducts rehearsals in areas not subject to enemy observation and performs extensive movements and resupply under limited visibility. OPSEC measures vary because of higher headquarters deception efforts.

f. **R&S Plan.** The TF R&S plan directs the employment of intelligence assets under TF control and assigns intelligence and security tasks to subordinate units. Company teams typically provide security patrols to their fronts and establish OPs in accordance with the R&S plan. The scout platoon also conducts reconnaissance and security tasks in accordance with the R&S plan. Patrols may be established to maintain contact between units when company teams occupy separate assembly areas.

### 12-33. DEPARTURE FROM THE ASSEMBLY AREA

The planning considerations for occupying the assembly area are based largely on the anticipated future missions of units. Units are positioned in the assembly area so they can depart the assembly area en route to their assigned tactical missions without countermarching or moving through another unit.

a. **Placement of Start Point.** Units departing the assembly area must hit the SP at the correct interval and speed. To achieve this, the SP must be located a sufficient distance from the assembly area to allow units to maneuver out of their positions and configure for the road march before reaching the SP. The SP for a TF movement should be located an adequate distance from the assembly area to permit the company teams to attain proper speed and interval before crossing it.

b. **Liaison Officers.** When unit-to-unit dispersion or terrain in the assembly area prohibits visual contact, LNOs maintain contact between departing units and return to their parent units to initiate movement at the correct time.

---

## APPENDIX A

# INTEGRATION OF HEAVY AND LIGHT FORCES

*Employing tank and mechanized infantry task forces with light units is a combat multiplier. These operations take advantage of the light unit's ability to operate in restricted terrain (such as urban areas, forests, and mountains) and the mobility and firepower inherent in heavy units. To ensure mechanized and light assets are integrated and synchronized, forces should be mutually supporting based on the commander's concept of employment. This appendix addresses conditions battalion task force commanders must consider when planning and executing two types of tactical operations: when provided a light infantry company and when operating as part of a light brigade.*

### Section I. ORGANIZATION, CAPABILITIES, AND LIMITATIONS

Across the spectrum of operations there is an overlap in which both armored and light forces can operate. The use of a mixed force in this overlap takes advantage of the strengths of both forces and offsets their respective weaknesses. Heavy/light operations occur when a mechanized/armored force has light forces attached. Light/heavy operations occur when a mechanized/armored force is under the OPCON of a light infantry force. The integration of armored and light forces can take advantage of the enemy force's structure to attack its weaknesses and seize the initiative .

**NOTE:** For the purpose of brevity, this appendix will use the term *heavy* to indicate BFV- and tank-equipped units.

#### A-1. HEAVY FORCES AND LIGHT INFANTRY OPERATIONS

The potential to use heavy and light forces together to capitalize on each other's strengths, offset weaknesses, and attack the perceived weaknesses of any hostile force in war and conflict is unlimited. The interjection of light forces in a heavy theater allows a flexible response to increasing tensions and a rapid response in the face of a sudden all-out attack.

a. **Factors of METT-TC.** Heavy and light infantry forces are not routinely mixed but can be effective given the proper situation. The decision to cross-attach light infantry is based on corps-level war planning or on the initiation of a subordinate commander's request for light infantry augmentation. In all cases, the factors of METT-TC drive the decision to use heavy and light forces together.

b. **Advantages and Challenges.** One advantage of mixing heavy and light infantry forces is greater tactical flexibility for the maneuver commander. In the offense, the light infantry company can infiltrate by ground to seize and hold restricted terrain, allowing the battalion task force to move faster, or it can air-assault into the enemy's rear, disrupting his defenses to create an exploitable weakness. Additionally, it can execute tasks that heavy forces may not have the manpower or training to perform, such as attacking in restricted terrain to defeat enemy infantry in prepared positions. In the defense, the light infantry company can defend in restricted terrain and allow the battalion task force to mass its heavy systems along the enemy's primary mounted avenue

of approach. Along with such flexibility, the integrated force also has the advantage of the mobility and firepower inherent in heavy units. The challenge of heavy and light operations is to understand the capabilities and limitations of each type of mechanized/armored and light force structure. To ensure effective integration of heavy and light assets, all forces should be mutually supporting based on the commander's concept of employment.

**A-2. LIGHT FORCES MISSIONS, CAPABILITIES, AND LIMITATIONS**

The battalion task force may support any of three primary types of light brigades: light infantry, airborne, and air assault. These organizations vary in capabilities and limitations and in their impact on the heavy force. For example, differences in the organization of the brigade headquarters and in antiarmor capability may affect the battalion task force mission. The commander and staff must understand the organization of the light forces that the task force may support and light forces that may be attached or OPCON to the task force.

a. **Missions.** The missions given to a light infantry battalion in heavy/light operations must consider the enemy's armored superiority in mobility and firepower. The light infantry battalion must offset its vulnerabilities with dispersion, cover and concealment, and use of close and hindering terrain to slow the enemy. Table A-1 shows possible light infantry tasks.

HEAVY TASK FORCE MISSIONS	LIGHT INFANTRY COMPANY TASK
<b>Movement to Contact</b>	Clear and secure restricted areas; follow and support.
<b>Attack</b>	Air-assault to fix or destroy enemy targets; infiltrate or air-assault to seize objectives; breach obstacles; create a penetration.
<b>Exploitation</b>	Secure LOC; air-assault to seize terrain or attack enemy forces.
<b>Pursuit</b>	Clear bypassed forces; air-assault to block enemy escape.
<b>Follow and Support</b>	Secure key terrain and LOC; provide rear security.
<b>Defense</b>	Block dismounted avenues; perform security tasks; occupy strongpoint; ambush; provide rear area security; conduct military operations on urbanized terrain.
<b>Linkup</b>	Serve as follow-up echelon.
<b>Demonstration</b>	Conduct display operations.
<b>Retrograde Operations</b>	Provide rear security, clear routes, occupy positions in depth; perform reconnaissance or deception; conduct stay-behind operations.

**Table A-1. Example of possible light infantry tasks.**



- b. **Capabilities.** Light forces have the capabilities to perform the following actions:
- Seize, occupy, and hold terrain.
  - Move on foot or by aircraft, truck, or amphibious vehicle.
  - Move in all types of terrain.
  - Conduct operations with tank and mechanized infantry forces.
  - Conduct covert breaches.
  - Conduct air assault operations.
  - Take part in counterinsurgency operations within a larger unit.
  - Rapidly accept and integrate augmenting forces.
- c. **Limitations.** Light forces have the following limitations:
- They must depend on nonorganic transportation for rapid movement over long distances.
  - Without protective clothing, they are vulnerable to the effects of prolonged NBC exposure.
  - They require external support when they must operate for an extended period.
  - Unless dug in with overhead cover, they are extremely vulnerable to indirect fires.
  - Unless dug in, they are vulnerable in open terrain to long-range direct fires.

### **A-3. LIGHT INFANTRY BRIGADE**

Light infantry brigades have the most austere of the three light headquarters organizations in terms of communications capabilities and the number of staff officers. There are few vehicles in the main CP. Organizational maintenance is centralized at the brigade maintenance section. All Class I rations are prepared by the brigade mess team. Like the light infantry division, the brigade must depend on corps-level transportation assets. A key characteristic of the light infantry brigade is its limited antiarmor capability. There are 12 TOWs and Javelins per brigade. In addition, the light infantry division has only one attack helicopter battalion and an air cavalry squadron.

### **A-4. AIRBORNE BRIGADE**

Once it completes entry operations, the airborne brigade essentially functions as a light infantry brigade. It has more CS and CSS assets than does the light infantry brigade and has 60 TOWs and 54 Dragons or Javelins. The airborne division has only one attack helicopter battalion and an air cavalry squadron.

### **A-5. AIR ASSAULT BRIGADE**

Staff and CSS functions in the air assault brigade are similar to those in tank and mechanized brigades. The air assault brigade uses helicopters to extend its command and control and CSS capabilities. Antiarmor capability is the same as for the airborne brigade. The air assault division has a combat aviation brigade, consisting of three attack helicopter battalions and an air cavalry squadron, that adds to its antiarmor capability.

### **A-6. LIGHT INFANTRY BATTALION**

The light infantry battalion is the most austere light battalion and the one whose organization is most different from that of a heavy battalion. There are only three rifle companies and a headquarters company in the battalion. It has four TOWs and 18

Dragons or Javelins. Organic fire support is provided by an 81-mm mortar platoon assigned to the headquarters company. Differences between this battalion and the air assault and airborne battalions are greatest in the organization of support and logistics elements. It has no trucks larger than its 27 cargo HMMWVs. The battalion has no mess team; Class I is prepared at brigade level. There is only one mechanic in the entire battalion; repairs are conducted at the brigade level. The battalion has only 18 long-range radios.

#### **A-7. AIR ASSAULT AND AIRBORNE BATTALIONS**

Once inserted, the air assault and airborne battalions perform much like the light infantry battalion, using walking as a primary means of transportation. Each battalion has ten 2-1/2 ton trucks and 36 cargo HMMWVs and can conduct nontactical movement by truck. Each has a mess section and a 16-man maintenance platoon. Air assault and airborne battalions have 30 long-range radios, 20 TOWs, and 18 Dragons or Javelins. An 81-mm mortar platoon assigned to the headquarters company provides organic fire support.

#### **A-8. LIGHT INFANTRY COMPANY**

The light infantry company has three platoons and a headquarters section,--a total of 129 soldiers. The company headquarters contains both the antiarmor section, consisting of six Dragons or Javelins, and the mortar section, which has two 60-mm mortars. The rifle platoons, with 34 soldiers each, are organized into three squads and a headquarters section, which controls the platoon's machine guns. Each rifle squad consists of two fire teams.

#### **A-9. AIRBORNE AND AIR ASSAULT COMPANIES**

Airborne and air assault companies are capable of independent action. Each of the three rifle platoons has a weapons squad as well as three rifle squads. The weapons squads have both machine-gun crews and antiarmor missile crews. The company headquarters retains control of the 60-mm mortar section.

### **Section II. PLANNING CONSIDERATIONS**

Employment of heavy and light forces requires thorough integration of the operating systems of both types of units. This section focuses on planning considerations for each of the seven operating systems.

#### **A-10. COMMAND AND CONTROL**

The directing headquarters designates command relationships between light infantry and the tank or mechanized infantry force. The command relationship between a light unit and a heavy unit can be either attached or OPCON. A light unit attached to a heavy unit can normally be adequately supported. Attachment of a heavy unit to a light unit, however, requires considerable CS and CSS support from the heavy unit's parent organization or from higher-level support assets.

a. **Communications.** Light units normally have considerably less digital and long-range communications capability than their heavy-force counterparts. A gaining heavy unit must therefore thoroughly analyze the communications requirements of an attached light unit.

b. **Liaison Officers.** Units conducting light/heavy or heavy/light operations normally exchange LNOs who assist in joint operational planning, coordinate the development of orders and overlays, and serve as advisors to the counterpart units. In addition, leaders from the attached unit may be required to perform special functions in the light/heavy or heavy/light configuration.

#### A-11. INTELLIGENCE

Detailed intelligence is critical in integrating light infantry with tank and mechanized infantry forces. Light forces orient on concentrations of enemy units, including counterattack forces and artillery and air defense assets; they also focus on the enemy's infantry avenues of approach and LZs and PZs.

#### A-12. MANEUVER

Either the light force or the tank or mechanized infantry force can fix the enemy, allowing the other force to maneuver. Whether it conducts the fixing operation or maneuver, the light force requires the advantage of close terrain. The following maneuver considerations apply in light/heavy or heavy/light employment.

a. **Operational Tempo.** The differences between the operational tempo of light infantry and that of tanks and mechanized infantry is always a key consideration, as are rehearsal schedules. An early rehearsal may be required both to allow light and heavy forces to take part jointly and to resolve the operational differences effectively. Task-organize as early as possible to facilitate multiple rehearsals, SOP reviews, and orders development.

b. **Employment.** The light force is best suited to close and restricted terrain, where it can impede the enemy's mobility and nullify his ability to use long-range weapons and observation assets.

c. **Movement.** To help prevent detection, leaders should plan the movement of light infantry to coincide with limited visibility conditions such as darkness, severe weather, smoke, or fog.

d. **Fires.** Direct and indirect fires should be mutually supporting during integrated operations. The company team can use its long-range direct fires to provide suppression, allowing infantry units to maneuver. Conversely, light infantry forces can provide overwatch or support by fire to the company team, allowing tanks and BFVs to maneuver in restricted terrain.

e. **Infiltration.** Mechanized units can assist infiltration by augmenting security at the LD. They can use their thermal capability to scan the area for enemy forces and can provide direct fire support as necessary.

#### A-13. FIRE SUPPORT

The mechanized infantry or armored force must recognize that dismounted infantry operations focus on stealth, which might not allow for preparatory and other preliminary fires. Fire support available to each force must be integrated into the fire support plan. Planners must know the organizations, capabilities, and limitations of all forces involved, particularly their digital and nondigital capabilities. During planning and preparation, a liaison team helps synchronize fire support. Restrictive fire control measures must be jointly developed and understood by everyone.

#### **A-14. AIR DEFENSE**

Air defense assets may be deployed to fight and provide protection within the scope and design of any organization. Because infantry forces frequently maneuver in restricted terrain, Avenger and BSFV coverage may not be feasible. In such operations, man-portable Stingers should be allocated to support the infantry.

#### **A-15. MOBILITY AND SURVIVABILITY**

A common obstacle plan must be developed for light/heavy or heavy/light operations. Light forces may be used to reduce obstacles and clear choke points for the tank and mechanized infantry forces. In breaching operations, light forces must ensure the breach is large enough for the widest vehicle in the operation. Survivability remains the priority for light forces, which must prepare to take advantage of the engineer assets available to the mechanized infantry and armored forces.

#### **A-16. NUCLEAR, BIOLOGICAL, CHEMICAL**

The light force lacks decontamination equipment and is more limited in an NBC environment than the mechanized infantry and armored force. The soldiers need to carry protective clothing in addition to their standard loads, which affects the mobility of the light force. When higher headquarters cannot provide transportation assets, planners should arrange for mechanized infantry and armored unit vehicles to help transport light-force NBC equipment. A mechanized infantry and tank battalion task force also has expedient devices and water-hauling capabilities it can use to offset light-force shortfalls. Transporting these items with mechanized or armored assets reduces the load of light infantry units. Commanders must consider METT-TC and must plan linkup points to ensure the light unit obtains these critical items as it needs them.

#### **A-17. COMBAT SERVICE SUPPORT**

Light units are not organized, equipped, or trained to meet the support requirements of a heavy force. The light force relies on considerable assistance from the heavy force's organic elements and from corps-level support assets. Heavy units, however, should be able to provide support to a light infantry element. For a more detailed discussion of CSS considerations, refer to Section V of this appendix.

### **Section III. OPERATIONS**

Employment of heavy and light forces requires thorough understanding of tactical employment of light forces during the conduct of the offense or defense. This section focuses on tactical employment of combined heavy and light forces during combat operations.

#### **A-18. OFFENSIVE OPERATIONS**

The fundamentals, principles, and concepts discussed in Chapter 5 apply to light infantry as well as to heavy force offensive operations. While combining these forces in the offense can work many different ways, the following are some of the most common examples.

a. **Heavy Force Support, Light Force Assault.** Tanks and BFVs support by fire while the infantry assaults the objective. The vehicles fire from hull-defilade positions

until the infantry masks their fires. This is the most effective method for BFVs and may be used with tanks when antitank weapons or obstacles prohibit them from moving to the objective.

(1) This method may incorporate a feint to deceive the enemy as to the location of the main attack. If so, the heavy force supporting attack is timed to divert the enemy's attention from the light force's assault. The fires of the heavy force may also cover the sound of the infantry's approach or breach. Close coordination is vital for effective fire control.

(2) This method may vary when either the terrain or disposition of the enemy limits the ability of the heavy force to support the infantry's attack. In this case, the heavy force may be tasked to suppress or fix adjacent enemy positions or to accomplish other tasks to isolate the objective area.

b. **Simultaneous Assault.** With this method, light and heavy forces advance together, and infantry and vehicles move at the same speed. The vehicles may advance rapidly for short distances, stop and provide overwatch, then move forward again when the infantry comes abreast. Tanks are best suited to assault under fire. Mechanized infantry vehicles may also be used in this manner but only when the threat of antitank fires is small. If an antitank threat exists, infantry usually leads while the vehicles follow to provide fire support.

(1) Simultaneous assault may be used when the enemy situation is vague, when the objective is large and consists of both open and restricted terrain, or when visibility, fields of fire, and the movements of the heavy force are restricted. These conditions exist during periods of restricted visibility and in restricted terrain, such as in urban areas and wooded areas. The vehicles provide immediate close direct fires, and the infantry protects the vehicles from individual antitank measures.

(2) This method sometimes requires infantry to follow a safe distance behind the tanks or BFVs for protection from frontal fires. This is true when the main enemy threat is small arms fire. From behind the tanks or BFVs, the infantry can protect the flanks and rear of the vehicles from handheld antitank weapons.

(3) Simultaneous assault may require light and heavy forces to advance together in operations that require long, fast moves. Infantrymen ride on the armored vehicles or trucks until they make contact with the enemy. Although this is a quick way to move, it exposes infantry to enemy fire, particularly airburst munitions, and may interfere with the operation of BFVs and tanks.

c. **Assault from Different Directions.** With this method, heavy and light forces converge on the objective from different directions. BFVs, tanks, and light infantry advance by different routes and assault the objective at the same time. For this synchronization to succeed, the light infantry elements maneuver and close on their assault position, ideally under cover of darkness or poor weather. The synchronization of the assault provides surprise, increases fire effect, and maximizes shock action. Planning, disseminating, and rehearsing the coordination of direct and indirect fire measures are critical in this type of operation.

(1) Assault from different directions is effective when using tanks and BFVs and when two conditions exist. First, terrain must be at least partly open and free from mines and other armored vehicle obstacles. Second, supporting fires and smoke must effectively

neutralize enemy antitank weapons during the brief period required for the tanks/BFVs to move from their assault positions to the near edge of the objective.

(2) This method requires coordination of light infantry and heavy forces to provide effective fire control on the objective. When conditions prohibit the armored vehicles from advancing rapidly, infantry should accompany them to provide protection.

### **A-19. EXPLOITATION**

Exploitation follows success in battle. The heavy force is usually the most capable exploitation force. It takes full advantage of the enemy's disorganization by driving into his rear to destroy and defeat him. A heavy force operating as a team (BFV- and tank-equipped units) may exploit the local defeat of an enemy force or the capture of an enemy position. The purpose of this type of operation is to prevent reconstitution of enemy defenses, to prevent enemy withdrawal, and to secure deep objectives. A common combination is a heavy task force reinforced by an attached light infantry company, engineers, and other supporting units. The infantry may be transported in armored vehicles or trucks or may ride on the tanks. Riding on tanks reduces road space, decreases supply problems, and keeps the members of the team together. Infantry leaders ride with the corresponding tank unit commanders. The TF commander must weigh the likelihood of enemy contact against the need for speed.

### **A-20. DEFENSIVE OPERATIONS**

The combination of light infantry and heavy forces is well suited to conduct defensive operations. The heavy force provides a concentration of antiarmor weapons and the capability to counterattack by fire or maneuver rapidly. The light force can occupy strongpoints, conduct spoiling attacks, and conduct stay-behind operations. The fundamentals, principles, and concepts discussed in Chapter 6 apply to combined light and heavy force defensive operations.

a. **Light Force in Depth, Heavy Force Forward.** The mechanized infantry and armored unit covers forward of a light unit's defense, masking the location of the light unit. While passing through the light unit's positions, mechanized infantry and armored units provide most of their own overwatch protection. Careful planning is required for battle handover to the light unit. Light unit direct fire overwatch weapons that are able to support from inside the battle handover line are scarce. To solve this problem, the mechanized infantry and armored force can provide some of its antiarmor assets to the light infantry. These assets usually are provided at company level and above.

b. **Light Force Forward, Heavy Force in Depth.** The heavy force assumes positions in depth behind the light unit's defense. The light unit's forward deployment shapes the battlefield for decisive action by the heavy forces. The light unit leaves an avenue of approach into the heavy force's engagement area. At the same time, the light unit prevents the enemy from using restricted terrain. If the enemy penetrates the light unit, the heavy force counterattacks, destroying the enemy or blocking him until additional units can be repositioned to destroy him. To support the counterattack, the light unit identifies the location of the enemy's main effort, slows his advance, and destroys his command, control, and CS elements. The light unit can guide the counterattacking force through restricted terrain to surprise the enemy on his flank.

c. **Light Force Terrain-Oriented, Heavy Force Enemy-Oriented.** Terrain-oriented refers to area defense; enemy-oriented refers to mobile defense. With this method, the entire force defends along the FEBA. The light force, whether used as a flanking or covering force or positioned in depth, places its elements to use restricted terrain effectively. The heavy force keeps its freedom of maneuver. To protect the light unit, contact points between light and heavy forces should be in restricted terrain. A light unit may defend to hold terrain while the tanks and BFVs maneuver to destroy the enemy from the flanks or rear.

d. **Strongpoint.** The light unit, with additional assets, occupies a strongpoint. The strongpoint forces the enemy into the heavy force’s engagement area.

e. **Stay-Behind Operations.** The light unit occupies hide positions well forward of the FEBA. As the enemy passes, the light force attacks the enemy’s command, control, CS, or CSS elements. The heavy force defends against enemy maneuver forces.

**A-21. RETROGRADE OPERATIONS**

Retrograde operations include delays and withdrawals, which gain time and avoid decisive action. Heavy forces are employed against the enemy forces and avenues of approach that most threaten the operation. To move to subsequent positions, light forces need additional transportation assets, including helicopters. Basic movement techniques include maneuver and a reverse bounding overwatch. Heavy forces with small light force units mounted, along with infantry reconnaissance platoons and antitank elements, move to subsequent delay positions under the cover of mutually supporting forces.

**Section IV. ADDITIONAL OPERATIONAL CONSIDERATIONS**

The following additional considerations apply in light/heavy or heavy/light operations.

**A-22. DISMOUNTED INFANTRY MOVEMENT RATES**

Commanders of heavy forces often overestimate (or simply fail to recognize) the speed with which dismounted elements can move. Numerous factors can affect the rate of march for light forces: tactical considerations, weather, terrain, march discipline, acclimatization, availability of water and rations, morale, individual soldiers’ self-confidence, and individual loads. Table A-2 summarizes dismounted rates of march for normal terrain. The normal distance covered by a dismounted force in a 24-hour period is from 20 to 32 kilometers, marching from five to eight hours at a rate of 4 kmph. A march in excess of 32 kilometers in 24 hours is considered a forced march. Forced marches increase the number of hours marched, not the rate of march, and can be expected to impair the unit’s fighting efficiency. Absolute maximum distances for dismounted marches are 56 kilometers in 24 hours, 96 kilometers in 48 hours, or 128 kilometers in 72 hours.

	<b>ROADS</b>	<b>CROSS-COUNTRY</b>
<b>Day</b>	4.0 kmph	2.4 kmph
<b>Night</b>	3.2 kmph	1.6 kmph

**Table A-2. Dismounted rates of march (normal terrain).**

### A-23. TANK MOUNTED INFANTRY

An additional maneuver consideration for a light/heavy or heavy/light operation is the decision of whether to move infantrymen on tanks. This mode of transportation can be difficult but is not impossible. It does, in fact, afford some significant advantages. The mounted infantry can provide additional security for the company team. When the team conducts a halt or must execute a breach or other tactical tasks, infantry assets are readily available to provide support and security. The commander must weigh the potential dangers of carrying tank-mounted infantrymen against the advantages of mobility and security they can provide. For specific procedures and safety considerations involved in mounting infantry on tanks, refer to FM 3-20.15.

### A-24. SAFETY CONSIDERATIONS

Initially, most infantrymen are not familiar with the hazards that may arise during operations with tanks, BFVs, and other armored vehicles. The most obvious of these include the dangers associated with main-gun fire and the inability of armored vehicle crews to see people and objects near their vehicles. Leaders of heavy and light units alike must ensure that their troops understand the following points of operational safety.

a. **Discarding Sabot.** Tank sabot rounds and BFV antipersonnel rounds discard stabilizing petals when fired, creating a downrange hazard for infantry. The aluminum petals of the tank rounds are discarded in an area extending 70 meters to the left and right of the gun-target line, out to a range of 1 kilometer. The danger zone for BFV rounds extends 30 degrees to the left and right of the gun-target line, out to 200 meters from the vehicle. Infantrymen should not be in or near the direct line of fire for the tank main gun or BFV cannon unless they are under adequate overhead cover.

b. **Noise.** Tank main guns create noise in excess of 140 decibels. Repeated exposure to this level of noise can cause severe hearing loss and even deafness. In addition, dangerous noise levels may extend more than 600 meters from the tank. Single-layer hearing protection, such as earplugs, allows infantrymen to work within 25 meters of the side or rear of the tank without significant hazard.

c. **Ground Movement Hazards.** Crewmen on tanks and BFVs have very limited abilities to see anyone on the ground to the side or rear of the vehicle. As a result, vehicle crews and dismounted infantrymen share responsibility for avoiding the hazards this may create. Infantrymen must maintain a safe distance from armored vehicles at all times. In addition, when they work close to an armored vehicle, dismounted soldiers must ensure that the vehicle commander knows their location at all times.

**NOTE:** A related hazard is that M1-series tanks are deceptively quiet and may be difficult for infantrymen to hear as they approach. As noted, vehicle crews and dismounted infantrymen share the responsibility for eliminating potential dangers in this situation.

d. **M1 Exhaust Plume Hazard.** M1-series tanks have an extremely hot exhaust plume that exits from the rear of the tank and angles downward. This exhaust is hot enough to burn skin and clothing.



e. **TOW Missile System.** The TOW missile system has a dangerous area extending 75 meters to the rear of the vehicle in a 90-degree "cone." The area is divided into a 50-meter danger zone and a 25-meter caution zone.

## **Section V. COMBAT SERVICE SUPPORT OPERATIONS**

CSS planning and execution are critical elements for integration of light and heavy forces. Light brigades are not organized, equipped, or trained to meet the support requirements of a heavy company team. CSS may be further complicated if the heavy force is operating across a large geographical area to meet the demands of a decentralized mission. The following discussion covers CSS considerations that may affect light/heavy and heavy/light operations.

### **A-25. PLANNING AND INTEGRATION**

Light/heavy operations may require the heavy team to integrate into the light brigade organization early in the deployment phase. In turn, this may require CSS assets to move into the theater of operations very early as well, usually at the same time as the command and control elements. Specific support requirements, including needed quantities of supplies, depend on the mission and must be planned and coordinated as early as possible. In addition, because the light brigade does not possess the required logistical redundancy to sustain the heavy company team, it is imperative that mission requirements calling for division- or corps-level CSS assets be identified early in the planning process.

### **A-26. SUPPLY REQUIREMENTS**

Operations with a light brigade create many unique supply considerations for the heavy task force. The sheer bulk and volume of supplies required by the heavy task force merit special attention during the planning and preparation phases. The following paragraphs examine some of these supply-related considerations.

a. **Class I.** Class I food requirements are determined based on the heavy team's personnel strength reports. This process may be complicated by unique mission requirements imposed on the team, such as rapid changes in task organization or dispersion of subordinate company teams over a wide area.

b. **Class II.** Many Class II items required by tank and BFV crews, such as specialized tools and Nomex clothing, may be difficult to obtain in a light organization. Although such items can be ordered through normal supply channels, the heavy task force may face significant delays in receiving them. To overcome this problem, the heavy task force should identify any potential shortages and arrange to obtain the needed supplies before leaving its parent organization.

c. **Class III.** The fuel and other POL products required by the heavy task force are extremely bulky; they present the greatest CSS challenges in planning and preparing for light/heavy operations. Transportation support must be planned carefully. For example, planners must consider the placement of fuel HEMTTs during all phases of the operation. They must also focus on general-use POL products, such as lubricants, that are not ordinarily used by the light brigade. As noted previously, the heavy task force should stock its basic load of these items, as well as make necessary resupply arrangements, before attachment to the light brigade.

d. **Class IV.** The heavy task force does not have any unique requirements for barrier or fortification materials. The main consideration is that any Class IV materials that the commander wants may have to be loaded and carried prior to attachment.

e. **Class V.** Along with POL products, ammunition for the heavy force presents the greatest transportation challenge in light/heavy operations. Planning for Class V resupply should parallel that for Class III; key considerations include anticipated mission requirements and the availability of HEMTTs. Ammunition may be prestocked based on expected consumption rates.

f. **Class VI.** Light/heavy operations create no unique requirements for personal demand items and sundries.

g. **Class VII.** Class VII consists of major end items, such as "float" tanks or BFVs. The handling of these items requires thorough planning to determine transportation requirements and positioning in the scheme of the operation.

h. **Class VIII.** The heavy force involved in light/heavy operations may deploy with additional Class VIII to sustain projected METT-TC requirements.

i. **Class IX.** Repair parts for combat vehicles are essential to the sustainment of the heavy force. PLL and ASL stockage levels must be carefully considered before light/heavy operations begin. The heavy task force may find it advantageous to prestock selected items to meet its anticipated needs.

#### **A-27. OPERATIONAL CONSIDERATIONS**

A heavy task force can satisfy the CSS needs of a light infantry company more easily than an infantry brigade can satisfy the needs of a heavy task force or company team.

a. **Heavy Task Force with Infantry Company.** Except for mortar rounds, the mechanized infantry unit can provide all munitions the light infantry company needs. The S4 must plan to receive and move 120-mm, 81-mm, or 60-mm mortar munitions.

b. **Infantry Brigade with Heavy Task Force or Company Team.** Adding a mechanized infantry and tank battalion task force or company team to an infantry brigade significantly increases the fuel, ammunition, and maintenance that must be delivered to the forward area support team or the forward support battalions. The infantry brigade lacks the transportation required to support even a small heavy force, particularly the HETs, for armored vehicle evacuation. The heavy task force S4 must constantly anticipate the battalion task force's needs to allow the infantry brigade S4 more time to react. Support packages may be required for the heavy element that is attached or under OPCON of the light force. The preferred method of command relationship is OPCON, which permits the heavy task force to continue receiving support from its FSB. The support package may need to include fuel, HEMTTs and operators, HETs with drivers, tracked ambulances, and maintenance support teams.

## APPENDIX B

**AVIATION SUPPORT OF GROUND OPERATIONS**

*Army aviation's greatest contribution to the battlefield is providing the ground maneuver commander the ability to apply decisive combat power at critical times virtually anywhere on the battlefield. This combat power may be in the form of direct fire support from aviation maneuver units, the insertion of overwhelming infantry forces, or artillery fires delivered via air assault. This versatility gives the maneuver commander a decisive advantage on the battlefield. Ground maneuver commanders synchronize aviation maneuver with ground maneuver to enhance offensive and defensive operations. This synchronization allows the ground maneuver commander to shape the battlefield and to influence events throughout his AO.*

**B-1. ARMY AVIATION MISSIONS**

Aviation units operate within the framework of the ground regime. As fully integrated members of the combined arms team, aviation units conduct combat, combat support, and combat service support operations 24 hours a day across the entire length and breadth of the AO.

- a. **Combat Missions.** Aviation combat missions include--
  - Reconnaissance
  - Security.
  - Attack.
  - Air assault.
  - Special operations.
  - Theater missile defense (TMD).
  - Support by fire.
- b. **Combat Support Missions.** Aviation CS missions consist of the operational support and sustainment provided to forces in combat by aviation units. These include--
  - Command, control, communications, and intelligence (C3I).
  - Air movement.
  - Electronic warfare.
  - Aerial mine warfare.
  - Combat search and rescue (CSAR).
  - Air traffic services (ATS).
- c. **Combat Service Support Missions.** Aviation CSS missions consist of the assistance provided by aviation forces to sustain combat forces. These include--
  - Aerial sustainment.
  - Casualty evacuation.

**B-2. OFFENSIVE OPERATIONS**

Aviation assets contribute during offensive operations by assisting the TF commander in finding, fixing, and engaging the enemy.

a. **Movement to Contact.** During movement to contact operations, aviation assets can find, fix, and destroy the enemy. This allows the maneuver commander to focus on finding the enemy in an expedited manner, thus allowing him to develop the situation early without premature deployment of the main body.

(1) AH-64 Apache and OH-58D helicopters are extremely effective in limited visibility during movement to contact operations due to their night vision capabilities.

(2) During movement to contact operations, aviation assets may perform additional tasks, to include--

- Conducting armed reconnaissance or reconnaissance in force to gain and maintain enemy contact.
- Screening the front, flank, or rear of the ground maneuver unit.
- Acting as the rapid reaction force to conduct hasty attacks during a meeting engagement.
- Providing suppressive fires to allow for disengagement of friendly forces.
- Conducting air movements for resupply.
- Conducting CASEVAC if necessary.

b. **Attack.** During attack operations, aviation assets can assist the ground maneuver commander in destroying targets throughout the TF AO through hasty and deliberate attacks. The commander may employ aviation assets to--

- Overwatch assault objectives.
- Attack the enemy's flank or rear to divert his attention away from the main or supporting attack.
- Conduct forward, flank, or rear screening.
- Conduct air assaults to seize key terrain.
- Conduct air movement of remotely monitored battlefield sensor system (REMBASS) equipment to assist in enemy detection.
- Provide air assault security.
- Conduct CASEVAC operations.
- Conduct reconnaissance operations.
- Conduct deception operations to prevent detection of the ground maneuver force.
- Enhance C2 by providing an air mobile platform for the TF commander.
- Provide pinpoint laser guidance for artillery fires.
- Conduct air movements for resupply.

c. **Exploitation.** During exploitation operations, aviation assets can assist the TF commander in maintaining the momentum gained by the attacking forces. The commander may employ aviation assets to--

- Attack the enemy's flanks and rear to maintain constant pressure on the defeated force.
- Attack rear area C2 and CSS assets.
- Act as reserve to blunt any counterattacks or to provide the decisive blow by attacking to destroy lucrative targets.
- Screen vulnerable flanks.
- Conduct air assaults to seize key terrain and maintain momentum.
- Provide air assault security.

- Conduct CASEVAC operations.
- Enhance C2 by providing an air mobile platform for the TF commander.
- Provide pinpoint laser guidance for artillery fires.
- Conduct air movements for resupply.

d. **Pursuit.** As the success of the exploitation develops, the speed of army aviation is ideally suited to maintain enemy contact, develop the situation, and deliver precision fires on enemy areas of resistance. The TF commander may employ aviation assets to--

- Attack to destroy, disrupt, or attrit counterattacking or reserve forces.
- Attack to fix withdrawing forces.
- Screen pursuing ground maneuver forces.
- Conduct air assaults to seize key terrain.
- Conduct air movement operations to resupply committed forces rapidly and maintain the momentum.
- Conduct CASEVAC operations.
- Enhance C2 by providing an air mobile platform for the TF commander.
- Provide pinpoint laser guidance for artillery fires.
- Conduct air movements for resupply.

### **B-3. DEFENSIVE OPERATIONS**

During defensive operations, the speed and mobility of aviation assets can help maximize concentration and flexibility.

a. **Area Defense.** During an area defense, aviation assets can support the ground maneuver commander's preparation and defensive efforts. The TF commander may employ aviation to--

- Attack to fix enemy forces in the security zone.
- Screen during ground movement.
- Conduct reconnaissance, counterreconnaissance, and security operations, especially at night.
- Conduct air movement operations.
- Conduct CASEVAC operations.
- Emplace minefields using the Volcano mine system.
- Enhance C2 by providing an air mobile platform for the TF commander.
- Provide pinpoint laser guidance for artillery fires.
- Conduct air movements for resupply.

b. **Mobile Defense.** During a mobile defense, aviation assets can work in conjunction with ground maneuver forces to create a more lethal striking force to bring simultaneous fires to bear upon the enemy from unexpected directions. In a mobile defense, the TF commander may employ aviation to--

- Attack to fix enemy forces in the security zone.
- Screen during ground movement.
- Conduct reconnaissance, counterreconnaissance, and security operations, especially at night.
- Conduct air movement operations.
- Conduct CASEVAC operations.
- Emplace minefields using the Volcano mine system.

- Enhance C2 by providing an air mobile platform for the TF commander.
- Provide pinpoint laser guidance for artillery fires.
- Conduct air movements for resupply.

#### **B-4. RECONNAISSANCE AND SECURITY OPERATIONS**

Reconnaissance operations are conducted to obtain information about the enemy or the physical makeup of a particular area by visual or other detection methods. Successful reconnaissance collects quick, accurate information about the enemy and terrain. The purposes of security operations are to provide early and accurate warning of enemy operations, to provide the protected force with time and maneuver space to react to the enemy, and to develop the situation to allow the commander to employ the protected force effectively. The TF may conduct these operations to the front, flanks, or rear of a larger force. Security operations provide reaction time, maneuver space, and protection to the main body.

a. **Reconnaissance Operations.** The use of mounted, dismounted, and aerial techniques designed as part of a focused collection effort greatly enhances reconnaissance operations. Integrated air and ground reconnaissance operations provide not only an increased tempo in reconnaissance efforts but also provide the ground maneuver commander with depth and flexibility he might not otherwise have. Aviation assets support the collection effort by conducting route, zone and area reconnaissance for the ground maneuver commander.

(1) **Route Reconnaissance.** A route reconnaissance may be conducted to gain information on a specific route or axis of advance that is important to the commander's scheme of maneuver. The TF commander may employ aviation assets alone or in conjunction with TF scouts or other ground forces to conduct a route reconnaissance. Aviation assets greatly enhance the speed at which information is processed on the capability and security of routes so that they can be utilized to support combat operations. Integration of ground forces with aviation forces enables the TF commander to gain information on numerous routes in an expedited manner.

(2) **Zone Reconnaissance.** Since a zone reconnaissance is a directed effort to obtain detailed information concerning all routes, obstacles, terrain, and enemy forces within a defined zone, the TF commander may employ aviation assets to support a zone reconnaissance. During a zone reconnaissance, the TF commander may form air-ground teams with TF scouts to conduct operations. The aviation assets can accelerate the reconnaissance by reconnoitering any open terrain, reconnoitering forward of moving ground forces, screening the flank of ground maneuver forces, or orienting totally on finding, fixing, and destroying enemy forces. Employing aviation assets to support zone reconnaissance operations frees TF scouts to focus on close terrain, routes, and reconnaissance of obstacles and enemy. When air and ground force efforts are integrated, the TF commander is capable of developing the situation much faster than without.

(3) **Area Reconnaissance.** An area reconnaissance is conducted to gain information on a specific area that may be critical to combat operations. Like the zone reconnaissance, the TF commander may employ air-ground teams to accomplish this task. The TF commander may assign one specific area to each separate ground and air team or he may assign them an area together. The area reconnaissance proceeds much faster than the zone reconnaissance since the efforts focus on specific pieces of terrain.

b. **Security Operations.** Security operations allow the ground maneuver commander to gain information about the enemy and to provide reaction time, maneuver space and protection of friendly forces. This allows the ground maneuver commander to preserve valuable combat power that he can employ to destroy the enemy. Aviation assets support the TF commander by conducting screen and guard operations.

(1) **Screen.** During screening operations, the ground maneuver commander may employ aviation assets alone or in conjunction with ground forces to provide early warning, cover any exposed flanks, or fill any gaps between maneuver forces that cannot be secured in force. Because of the capabilities of aviation assets, especially at night, the TF commander can judiciously employ them on the battlefield to cover a very large area that cannot be covered on the ground alone. Additionally, aviation assets enable the TF commander to respond to developing enemy situations in an expeditious manner.

(2) **Guard.** During guard operations, aviation assets must be task-organized with ground maneuver assets such as a company/team conducting a counter-reconnaissance mission. Aviation assets support the TF commander by providing the same capabilities as with screen operations. During guard operations, the TF commander may utilize aviation assets to conduct reconnaissance, screen an exposed flank during movement, enhance C2, provide direct and indirect fire support, and position CS and CSS assets for future use.

c. **Available assets.** Any rotary-wing aircraft can conduct reconnaissance operations since they all greatly increase the range at which enemy movement can be detected. However, the two aircraft primarily dedicated to reconnaissance and security operations are the AH-64 Apache and OH-58D.

(1) **AH-64 Apache.** The AH-64A is a twin-engine, tandem-seat, four-bladed attack helicopter with a crew of two rated aviators. The pilot occupies the rear cockpit, and the copilot-gunner occupies the front cockpit. The aircraft has day, night, and limited adverse weather fighting capabilities. The aircraft is equipped with a laser rangefinder/designator (LRF/D). The LRF/D is used to designate for the firing of a Hellfire missile and provides range-to-target information for the fire control system. (See FM 1-112 for a detailed explanation of the aircraft.)

(2) **AH-64D Longbow Apache.** The AH-64D is a variant of the AH-64A. The AH-64D is designed to provide increased effectiveness over the capabilities of the AH-64A while greatly reducing the AH-64A's limitations. The AH-64D has several key improvements, including fire control radar (FCR), radio frequency (RF) Hellfire (fire and forget) missile system, digital communications, and other significant features. The day, night, and limited adverse weather fighting capabilities of the AH-64A are significantly enhanced in the AH-64D.

(3) **OH-58D Kiowa Warrior.** The OH-58D(I) Kiowa Warrior provides the maneuver commander with a versatile platform; it can be armed with various weapons systems and is suitable for employment in numerous types of situations and operations. The aircraft features a stabilized mast-mounted sight (MMS) with a low-light television sensor (TVS), thermal imaging sensor (TIS), and LRF/D. The aircrew of the Kiowa Warrior can detect a heat source in day or night conditions at a range of up to 15 kilometers and can provide laser designation of targets for laser-guided munitions.

(4) Maximum weapon ranges specified in Table B-1 are based on “best-case” function of the system. Maximum ranges should not be the only criteria used in the establishment of engagement areas to battle positions, attack by fire (ABF), or support by fire (SBF) positions. Ranges to target engagement distances are affected by the factors of METT-TC, and the single most important factor is weather because of the limiting impact on visibility and thermal sensors. Examples of some normal engagement weapon ranges are listed below:

- Hellfire:** 1000 to 6000 meters (day)  
1000 to 4000 meters (night)
- Rocket:** 1000 to 6000 meters
- 30mm:** 500 to 3000 meters
- .50 cal:** 500 to 1500 meters

Aircraft Type *	Hellfire	2.75" (70mm) Rockets	.50 caliber machine gun (rounds)	20mm cannon (rounds)	30mm Chaingun (rounds)
AH-64A/D	16	76			1,200
OH-58D **	4	14	500		
MAX RANGE	8 km	8 km	2 km	2 km	4 km

NOTES: \* Numbers in each column indicate the maximum load for each system. The total amount of ordnance carried will vary based on METT-TC and selected weapon configuration.  
\*\* One weapon system per side for Hellfire and 2.75-inch rocket.

**Table B-1. Rotary-wing aircraft.**

**B-5. RETROGRADE OPERATIONS**

During retrograde operations, aviation assets can assist the TF commander in movement away from an enemy force or to the rear.

a. **Delay.** In a delay operation, the TF commander trades space for time and preserves friendly combat power while inflicting maximum damage on the enemy. Aviation forces can assist by--

- Rapidly concentrating fires to allow disengagement and repositioning.
- Conducting surprise attacks to confuse advancing enemy forces.
- Emplacing Volcano minefields to supplement obstacles or to impede or canalize enemy movements.
- Conducting air assaults to move ground forces between delaying positions.
- Providing a C2 platform.

b. **Withdrawal.** During a withdrawal, the TF commander voluntarily disengages the enemy. This withdrawal may be conducted with or without enemy pressure. Aviation forces can assist the ground maneuver commander in a withdrawal by--

- Using attack helicopters in an offensive manner to attrit enemy maneuver and fire support units.
- Providing security for withdrawing friendly units.
- Acting as the reserve.
- Conducting CASEVAC operations.
- Emplacing ROM sites to refuel vehicles conducting the retirement.
- Providing a C2 platform.



## **B-6. AIR-GROUND INTEGRATION**

Direct fire aviation missions in the close fight differ greatly from engagements in a cross-FLOT operation. In a cross-FLOT operation, attack and cavalry aircraft can benefit from deliberate planning, freely engaging at maximum ranges with minimal concern of fratricide. Engagements in the close fight, on the other hand, often result in engagements within enemy direct-fire weapons system ranges that are in close proximity to friendly units. The hasty attack in the close fight typically lacks proper coordination between air and ground elements. The following paragraphs focus on the hasty attack within an air-ground integrated attack. Effective coordination between ground maneuver units and attack aviation maximizes the capabilities of the combined arms team while minimizing the risk of fratricide. The following major problem areas contribute to inadequate or ineffective air-ground integration:

- Aircrews' lack of understanding of the ground tactical plan or the TF commander's intent.
- Lack of common control measures that allow both air and ground units maximum freedom of fire and maneuver.
- Lack of methods of differentiating between enemy and friendly forces on the ground.

## **B-7. AIR-GROUND COORDINATION PROCEDURES**

Effective integration of air and ground assets begins with the supported TF element. When the aviation brigade or task force receives a mission to provide assistance to a ground unit engaged in close combat and planning time is minimal, the initial information provided by the unit in contact should be sufficient to get the aviation attack team out of the aviation tactical assembly area to a holding area in order to conduct direct coordination with the engaged maneuver unit. To ensure the air and ground forces exchange essential information, planners use a five-step procedure. The five major steps are maneuver brigade planning requirements, battalion close fight SITREP, attack team check-in, coordination for aviation close fires (ACF), and battle damage assessment and reattack. Since aviation assets are normally in a direct support role to the brigade, the TF S-3 air must conduct close coordination with the brigade S-3 air when requesting aviation support. This paragraph also discusses aviation employment considerations and maneuver brigade liaison officer coordination requirements.

a. **Step 1, Maneuver Brigade Planning Requirements.** The maneuver brigade, through its aviation liaison officer, provides the necessary information to meet planning requirements to the aviation brigade headquarters (Table B-2, page B-8). The initial planning and information to be passed to the aviation brigade headquarters includes the location of the holding area, air axis, and route or corridor for entry and exit through the brigade and battalion sector. The holding area should be in the sector of the TF involved in close combat. The holding area may be a concealed position or an aerial holding area that allows for final coordination between the attack team leader and the ground unit leader. It must be located within FM radio range of all units involved. Alternate holding areas, along with ingress and egress routes, must be designated if occupation is expected to last longer than 15 minutes. The ground maneuver task force S-3 air also provides the call signs and frequencies or SINCGARS hopsets and COMSEC information regarding the battalion in contact. In addition, the ground maneuver task force S-3 air provides a

current situation update for its AO and specifically for the supported company teams in the AO. This update includes a recommended engagement area that will allow for initial planning for battle positions, or attack by fire positions, or support by fire positions and possibly prevent unintentional overflight of enemy positions.

#### **MINIMUM PLANNING REQUIREMENTS**

1. **Current situation:** This should include friendly forces location and situation, enemy situation highlighting known ADA threat in the AO, and tentative engagement area coordinates.
2. **Brigade or battalion level graphics update:** This can be via MCS-P or radio communications. It updates critical items such as LOA, fire control measures, and base maneuver graphics to facilitate better integration into the friendly scheme of maneuver.
3. **Fire support coordination information:** This includes call signs and frequencies and locations of DS artillery and organic mortars.
4. **Ingress and egress routes into their AO:** This includes PPs into sector or zone and air routes to the holding area.
5. **Holding area for face-to-face coordination between the attack team and the TF in contact:** A holding area equates to an assault position. It must be out of enemy mortar range, out of range of enemy direct fire systems, and adequate in size to accommodate the number of aircraft assigned the mission.
6. **Call signs and frequencies of the TF in contact down to the company in contact:** Air-ground coordination on command frequencies is necessary to provide information for all elements involved.
7. **SINGARS:** Synchronize time.

**Table B-2. Minimum planning requirements.**

b. **Step 2, Task Force Close Fight SITREP.** En route to the holding area, the attack team leader contacts the ground maneuver TF on its FM command net to receive a close fight SITREP (Table B-3). This SITREP verifies the location of the holding area and a means to conduct additional coordination. The attack team leader receives an update from the ground maneuver TF on the enemy and friendly situations. The TF also verifies frequencies and call signs of the unit in contact. By this time, the TF S-3 air has contacted the company team commander in contact to inform him that attack aviation is en route to conduct a hasty attack.

1. **Enemy situation:** focusing on ADA in the AO, type of enemy vehicles/equipment position (center mass) and direction of movement if dispersed provide front line trace.
2. **Friendly situation:** location of company in contact, mission assigned to them, method of marking their position.
3. **Call sign and frequency verification.**
4. **Holding area verification:** if intended to be used for face-to-face coordination, a sign counter sign must be agreed upon i.e. using a light/heat source to provide a recognizable signature, answered by either aircraft IR lights or visible light flashes to signify which aircraft to approach.

**Table B-3. Task force close fight SITREP.**

**NOTE:** The examples of simulated radio traffic in this appendix are merely examples of what may occur.

**EXAMPLE**

**Attack Team**

“Bulldog 06 this is Blackjack 26, over”

“Bulldog 06, Blackjack 26 enroute to HA at grid VQ 98454287, request SITREP, over”

**Ground Maneuver Battalion**

“Blackjack 26 this is Bulldog 06, L/C, over”

“Blackjack 26 this is Bulldog 06, enemy situation follows, Hardrock 06 is taking direct fire from a platoon size armor element at grid VQ 96204362, Hardrock 06 elements are established on phase line Nevada center mass VQ 96000050, holding area VQ 94004000 expect radio coordination only, contact Hardrock 06 on FH 478, over”

(1) Upon receiving the required information from the TF, the aviation attack team leader changes frequency to the ground company's FM command net to conduct final coordination before ingressing on attack routes to BPs or ABF or SBF positions. Coordination begins with the ground maneuver company commander and ends with the leader of the lowest-level unit in contact.

(2) When the attack team leader conducts coordination with any key leader of the TF, the ground command net is the most suitable net on which both air and ground elements can conduct the operation. It allows all key leaders on the ground, including the TF FSO and the attack team leader and his attack crews, to communicate on one common net throughout the operation. Operating on the command net also allows the attack team to request responsive mortar fire for either suppression or immediate suppression of the enemy. The AH-64 Apache and the AH-1 Cobra are limited to only one FM radio due to aircraft configuration. However, the OH-58 is dual-FM capable, which gives the attack team leader the capability to maintain communications with the ground maneuver company, as well as the TF fire support element.

**EXAMPLE**

**Attack Team**

“Hardrock 06 this is Blackjack  
26 on FH 478, over”

**Ground Maneuver Company**

“Blackjack 26 this is Hardrock  
06, L/C over”

c. **Step 3, Attack Team Check-In.** Upon making initial radio contact with the ground maneuver unit in contact, the attack team leader executes a succinct check-in (Table B-4). This check-in includes the attack team's present location, which is normally its ground or aerial holding area; the attack team's composition; its armament load and weapons configuration; total station time; and its night-vision device capability. If not using a ground holding area due to METT-TC considerations, the attack team selects and occupies an aerial holding area within FM communications range until all required coordination is complete. The attack team leader and ground unit's key leaders must consider the effects on friendly forces of the various weapons carried by the attack aircraft prior to target selection and engagement. Weapons systems and munition selection for a given engagement depend on the factors of METT-TC. Point target weapons systems, such as Hellfire or TOW, are the preferred systems for armor or hardened targets when engaging targets in the close fight. The gun systems and the 2.75-inch rockets are the preferred systems and munitions for engaging troops in the open, soft targets such as trucks, and trenchworks. These area fire weapons systems pose a danger to friendly soldiers who may be in the lethality zone of the rounds or rockets. If this danger exists, then the leader on the ground must be very precise in describing the target he wants the aircraft to engage.

<ol style="list-style-type: none"> <li>1. Aircraft present location.</li> <li>2. Team composition.</li> <li>3. Munitions available.</li> <li>4. Station time.</li> <li>5. Night-vision device capable and type.</li> </ol>
--

**Table B-4. Attack team check-in.**

<u>EXAMPLE</u>	
<p><b><u>Attack Team</u></b>                      “Hardrock 06, Blackjack 26 is currently holding at grid VQ 98454287, 2 Kiowa Warriors with 450 rounds of .50 cal, 2 Hellfires each, half hour station time, all aircraft are NVG and FLIR capable, over”</p> <p>“Blackjack 26, roger”</p>	<p><b><u>Ground Maneuver Company</u></b></p> <p>“Blackjack 26, Hardrock 06, stand by, over”</p>

d. **Step 4, Coordination for Aviation Close Fires.** Time is the primary constraining factor for coordinating aviation close fires in the hasty attack. When possible, coordinate ACF face-to-face using the ACF coordination checklist (Figure B-1, page B-13). If time is not available for face-to-face coordination, then use radio-only communications and the request for immediate ACF. The request for immediate ACF may also be used when targets of opportunity require engagement through a target handoff between the ground and aviation elements after face-to-face coordination has been conducted. Although face-to-face coordination is preferred, the factors of METT-TC dictate how the commander in contact and the attack team leader conduct coordination. A major benefit of face-to-face coordination is the attack team's ability to talk to the ground commander with a map available and integrate into the ground scheme of maneuver. This also provides an opportunity for the attack team to update its maps with the maneuver TF's latest graphics.

(1) **Face-to-Face Coordination.** Once they receive the flight check-in, the ground company commander and attack team leader meet at the holding area and use the ACF coordination checklist to plan their attack (Figure B-1, Page B-13).

(a) There are several key elements of coordination to complete at the holding area:

- The target must be identified and its activity explained.
- The friendly forces positions must be identified on a map with a method of visually marking those positions passed on to the flight.

- If not previously done, the engagement area must be verified or defined.
- After defining the engagement area, the attack team leader must establish BPs and SBF positions.
- The scheme of maneuver for the ground elements must be explained with a commander's intent and description of what is considered the decisive point on the battlefield. With that information, the attack team provides an integrated scheme of maneuver.
- Existing or required fire control measures must be planned for and utilized to minimize the potential for fratricide.
- Key maneuver graphics that are required to support or understand the scheme of maneuver are passed between the ground commander and attack team leader.
- A method of marking targets, such as laser pointers and tracers, must be discussed.

(b) After completing this coordination, forces can execute the synchronized attack plan. Even with carefully thought out plans, however, situations will arise during the attack that will require flexibility and possibly the need to mass effects against targets of opportunity at a new location within the supported units sector or zone. Ground and air forces attack these targets of opportunity on a case-by-case basis using the request for immediate ACF. (See FM 1-111.)

(c) Ground and air commanders must consider the time available for this coordination. If they remain in the holding area for greater than 15 minutes, they must accept increased risk of holding area compromise. The factors of METT-TC dictate the extent of preplanning they can accomplish and the length of time they should occupy the holding area.

(2) ***Radio-Only Communications Coordination.*** When using radio-only communications coordination, leaders use a request for immediate ACF (FM 1-111). As previously discussed, leaders employ immediate ACF under two different conditions. The first is when they have already conducted face-to-face coordination and targets of opportunity arise. In this case, the ground element uses a request for immediate ACF for target handoff. The second condition is when time is not available for face-to-face coordination. In this case, the request for immediate ACF may be used as a stand-alone method of engagement where the call is used for communicating attack requirements from ground to air via radio only.

(a) When employing the request for immediate ACF under the first condition, it is assumed that air and ground units have exchanged all essential elements from the coordination checklist during face-to-face coordination at the holding area. During the attack, the TF or company commander calls the attack team leader and requests immediate ACFs for targets of opportunity. In this manner, the forces accomplish target handoff and the attack team leader redistributes fires accordingly.

(b) When employing the request for immediate ACF under the second condition, the ground commander in contact should brief only essential elements from the ACF coordination checklist as a SITREP via radio. He transmits this SITREP prior to a request for immediate ACF. Once he receives the flight check-in, the ground maneuver leader then provides a situation update, METT-TC permitting, containing essential elements from the ACF coordination checklist. After sending the SITREP, the ground commander

calls the attack aircraft forward from their holding area or aerial holding area using a request for immediate ACF. Whether the attack team utilizes a holding area or aerial holding area to conduct radio coordination depends on its abilities to maintain FM communication with the ground element in contact. As the attack team maintains position at an aerial holding area or within a holding area, the ground maneuver leader succinctly outlines the concept of his ground tactical plan. This includes updates on enemy composition, disposition, and most recent activities, particularly the location of air defense weapons. He also provides an update on the friendly situation to include the composition, disposition, and location of his forces and supporting artillery or mortar positions. After providing this information, the ground maneuver leader uses the request for immediate ACF format for attack and for subsequent re-attacks.

1. **\*Enemy situation: specific target identification.**
  2. **\*Friendly situation: location and method of marking friendly positions.**
  3. **\*Ground maneuver mission and scheme of maneuver.**
  4. Attack aircraft scheme of maneuver.
  5. Planned engagement area and BPs or SBF positions.
  6. Method of target marking.
  7. Fire coordination and fire restrictions.
  8. Map graphics update.
- \* To employ immediate aviation direct fire, the ground commander must brief the essential elements from the coordination checklist (**in bold**) via radio as a SITREP.

**Figure B-1. Aviation close fires coordination checklist.**

(c) After receipt of a request for immediate ACF, the attack team leader informs the ground unit leader of the battle position, support-by-fire position, or the series of positions his team will occupy. These are the positions that provide the best observation and fields of fire into the engagement or target area. The battle position or SBF position is the position from which the attack aircraft will engage the enemy with direct fire. It includes a number of individual aircraft firing positions and may be planned in advance or established as the situation dictates. Its size varies depending on the number of aircraft using the position, the size of the engagement area, and the type of terrain. The battle position or SBF position is normally offset from the flank of the friendly ground position, but close to the position of the requesting unit to facilitate efficient target handoffs. This

also ensures that rotor wash, ammunition casing expenditure and the general signature of the aircraft does not interfere with operations on the ground. The offset position also allows the aircraft to engage the enemy on its flanks rather than its front and lessens the risk of fratricide along the helicopter gun target line.

(d) The attack team leader then provides the ground maneuver unit leader with his concept for the team's attack on the objective. This may be as simple as relaying the attack route or direction from which the aircraft will come, the time required to move forward from their current position, and the location of the BP. Only on completion of coordination with the lowest unit in contact does the flight depart the holding area for the battle position. As the attack team moves out of the holding area, it uses nap of the earth (NOE) flight along attack routes to mask itself from ground enemy observation and enemy direct fire systems. The attack team leader maintains FM communications with the ground maneuver unit leader while he maintains internal communications on either his VHF or UHF net.

e. **Step 5, Battle Damage Assessment and Reattack.** After completing the requested ACF, the attack team leader provides a BDA to the TF commander. Based on his intent, the TF commander determines if a reattack is required to achieve his desired end state. Requests for ACF may continue until all munitions or fuel is expended. Upon request for a reattack, the attack team leader must consider the effects on duration and strength of coverage he can provide the ground maneuver commander. The attack team may need to devise a rearming and refueling plan, maintaining some of his aircraft on station with the unit in contact while the remainder returns to the FARP. Beyond the coordination with the ground maneuver unit in contact, the attack team leader must coordinate this effort with his higher headquarters.

## **B-8. REVIEW OF MAJOR POINTS**

In review, when an attack unit integrates into the ground scheme of maneuver, mission success requires detailed coordination between the attack unit and the ground unit already engaged in close combat.

a. The maneuver brigade provides the aviation brigade or task force with the information available on locations, routes, and communications before the attack team's departure from its assembly area.

b. The holding area is a concealed position where final coordination is made with the unit in contact before the attack team launches its attack. The aerial holding area is a point in space within the ground battalion's AO that is oriented towards the enemy to allow the attack team to receive requests for ACF and expedite the attack. The aerial holding area may be an alternate BP positioned outside the enemy's direct and indirect fire weapons ranges.

c. The attack team coordinates directly with the lowest level unit in contact. The preferred method of coordination is face-to-face; however, due to time constraints, radio coordination on the ground company FM command net may be the only method allowable.

d. The ground maneuver leaders and attack pilots must understand the ground effects of the attack team's weapons systems.

e. Final coordination with the ground maneuver unit includes agreeing on a method of identifying the friendly and enemy positions.



- f. The means of identifying friendly positions should take advantage of the FLIR, TIS, and night-vision goggle (NVG) capabilities of the attack team.
- g. The battle position or ABF position should be offset from the ground maneuver unit to maximize the effects of its weapons and to minimize the risk of fratricide. The ground commander should inform DS artillery and organic mortars of these positions in order to deconflict indirect fires into his sector or zone.
- h. After completion of the ACF, the attack team leader provides a BDA report to the ground maneuver commander.

### **B-9. EMPLOYMENT CONSIDERATIONS**

All aircrew and ground maneuver leaders should understand the strengths and weaknesses of available aviation sensors when employed in conjunction with target-marking equipment. This paragraph addresses several factors that operators should consider when marking targets for varied aviation optics. The equipment covered includes target-marking devices, NVGs, FLIR, TIS, TV/electrooptical (EO), electronic beacons, and laser designators.

a. **Target Identification and Friendly Position Marking.** The method of marking friendly positions is a critical piece of planning that must be considered thoroughly regardless of time available to the ground and air commanders. The ability of the aircrews to observe and identify ground signals easily is a critical factor in reducing fratricide and maximizing responsive aerial fires. The signal or combination of signals must be based on items commonly carried by ground maneuver units, must be acquirable by the night-vision or thermal imaging systems on the aircraft, and must be recognizable by the aircrew.

(1) Determine all required identification and marking procedures before starting a mission. Accurate and detailed maps, charts, or imagery facilitates aircrew orientation to the friendly scheme of maneuver. Aircrews must continue to work closely with the ground forces to identify friendly positions positively.

(2) Visual signaling or marking positions helps determine the disposition of friendly forces. Often, the simplest methods are the best. Traditional signaling devices, such as flares, strobes, and signaling mirrors, may be quite effective. Target marking, or orientation on enemy positions, may also be accomplished by signaling. Common techniques include the use of smoke, laser pointers, or tracers. Other devices are available to aid in the recognition of friendly forces and equipment where the fluid tactical situation and intermingling of forces in the close fight may make identification difficult. The use of glint tape, combat identification panels (CIPs), and infrared beacons assists in the clear identification of friendly ground forces, but ground lighting, thermal contrast, and intermediate obstructions influence the effectiveness of these devices.

(3) The proximity of friendly forces to targets requires positive identification and makes marking of friendly units and targets critical. All participants must clearly understand the procedures and be issued the appropriate devices. The fire support assets must also be familiar with the friendly marking system. Aircrews require positive identification of the target and friendly positions prior to firing. The methods to mark and identify targets are limited only by the creativity of the ground forces and aircrews. Commanders should use Table B-5, page B-17, as a reference but not limit themselves to only these methods. Methods employed must be adapted to the conditions prevalent at the

time. Positive air-to-ground communications are essential to coordinate and authenticate marks.

(4) Time permitting, attack aircraft may input a target grid into the aircraft GPS or inertial navigation system (INS). The target grid can provide fire control cues (range, heading, and time to the target) to aid in quicker target acquisition and help distinguish friendly from enemy. Because ACF missions may be "danger close" with short firing ranges, tracking time is minimal and therefore so is the time available to optimize the sensor.

METHOD	DAY/NT	ASSETS	FRIENDLY MARKS	TARGET MARKS	REMARKS
SMOKE	D/N	All	Good	Good	Easily identifiable. May compromise friendly position, obscure target, or warn of fire support employment. Placement may be difficult due to structures.
SMOKE (IR)	D/N	All/NVD at night	Good	Good	Easily identifiable. May compromise friendly position, obscure target, or warn of fire support employment. Placement may be difficult due to structures. Night marking is greatly enhanced by the use of IR reflective smoke.
ILLUM GRND BST	D/N	All	N/A	Good	Easily identified, may wash out NVDs.
SIGNAL MIRROR	D	All	Good	N/A	Avoids compromise of friendly location. Dependent on weather and available light and may be lost in reflections from other reflective surfaces (windshields, windows, water, etc.).
SPOT LIGHT	N	All	Good	Marginal	Highly visible to all. Compromises friendly position and warns of fire support employment. Effectiveness depends on degree of urban lighting.
IR SPOT LIGHT	N	All NVD	Good	Marginal	Visible to all with NVGs. Less likely to compromise than overt light. Effectiveness depends on degree of urban lighting.
IR LASER POINTER (below .4 watts)	N	All NVG	Good	Marginal	Effectiveness depends on degree of urban lighting.
IR LASER POINTER (above .4 watts)	N	All NVD	Good	Good	Less affected by ambient light and weather conditions. Highly effective under all but the most highly lit or worst weather conditions. IZLID-2 is the current example.
VISUAL LASER	N	All	Good	Marginal	Highly visible to all. Risk of compromise is high. Effectiveness depends on degree of urban lighting.
LASER DESIGNATOR	D/N	PGM- or LST-equipped	N/a	Good	Highly effective with PGM. Very restrictive laser acquisition cone and requires line of sight to target. May require pre-coordination of laser codes.
TRACERS	D/N	All	N/a	Marginal	May compromise position. May be difficult to distinguish mark from other gunfire. During daytime use, may be more effective to kick up dust surrounding target.
ELECTRONIC BEACON	D/N	See remarks	Excellent	Good	Ideal friendly marking device for AC-130 and some USAF fixed-wing aircraft (not compatible with Navy or Marine aircraft). Least impeded by urban terrain. Can be used as a TRP for target identification. Coordination with aircrews essential to ensure equipment and training compatibility.
STROBE (OVERT)	N	All	Marginal	N/A	Visible by all. Effectiveness depends on degree of urban lighting.
STROBE (IR)	N	All NVD	Good	N/A	Visible to all NVDs. Effectiveness depends on degree of urban lighting. Coded strobes aid in acquisition.
FLARE (OVERT)	D/N	All	Good	N/A	Visible to all. Easily identified by aircrew.
FLARE (IR)	N	All NVD	Good	N/A	Visible to all NVDs. Easily identified by aircrew.
GLINT/IR PANEL	N	All NVD	Good	N/A	Not readily detectable by enemy. Very effective except in highly lit areas.
COMBAT IDENTIFICATION PANEL	D/N	All FLIR	Good	N/A	Provides temperature contrast on vehicles or building. May be obscured by urban terrain.
VS-17 PANEL	D	All	Marginal	N/A	Only visible during daylight. Easily obscured by structures.
CHEMICAL HEAT SOURCES	D/N	All FLIR	Poor	N/A	Easily masked by urban structures and lost in thermal clutter. Difficult to acquire. Can be effective when used to contrast cold background or when aircrew knows general location.
SPINNING CHEM-LIGHT (OVERT)	N	All	Marginal	N/A	Provides unique signature. May be obscured by structures. Provides a distinct signature easily recognized. Effectiveness depends on degree of urban lighting.
SPINNING CHEM-LIGHT (IR)	N	All NVD	Marginal	N/A	Provides unique signature. May be obscured by structures. Effectiveness depends on degree of urban lighting.

**Table B-5. Target and friendly marking methods.**

b. **Laser Designation.** A major challenge for a gunner is achieving and keeping line of sight with a target or friendly position from a moving aircraft. Helicopters may use hover capabilities but only in the most permissive environments. Laser designation requires uninterrupted LOS to identify and engage a target. This may mean the lasing platform must be very near the target--possibly within enemy direct fire ranges, danger-close distances, or weapon arming distances--to keep the spot on the target until ordnance impact, especially in complex (urban) terrain. Smoke from burning vehicles or other fires may drift across the laser to the target line causing laser dispersion. Most laser designating platforms cannot actually see their laser spot on a target. Lasers are often boresighted to other supporting sensors like FLIR/TIS or TV/EO. If the supporting sensor cannot see a target, the laser cannot effectively mark the target. Further, even though a FLIR/TIS may "see" a target, the laser may not be capable of guiding ordnance against it since smoke, invisible to the FLIR/TIS, may attenuate the laser energy. The most significant contributor to laser attenuation, or nonselective scattering, is water vapor or absolute humidity. The impact of humidity on FLIR/TIS performance is greater than its impact on the laser. In other words, if you can detect the target in clear air then the laser should provide sufficient laser energy for seeker acquisition. As a rule of thumb, if you detect a target with a visual sensor and consistently determine a range to it with a laser range finder, then you can likely designate it satisfactorily for a laser-guided weapon. For low and medium threats where a great amount of time is available to use the FLIR/TIS to point the laser, the methods are simple. As the threat escalates and the time available for target acquisition shrinks, targeting with the FLIR/TIS becomes more difficult, and the delivery accuracy of the laser munitions may be degraded significantly.

c. **Television/Electro-Optical.** TV/EO sensors are subject to many of the same limitations as the naked eye, particularly TVS with no low-light capability. Aircrews may not be successful in acquiring a target and achieving lock-on if smoke, buildings, or other factors repeatedly interrupt line of sight. Low-light or all-light TV/EO sensors may require frequent gain and filter changes to accommodate varying light levels. Normal means of target and friendly identification may prove ineffective. Infrared strobes or even overt strobes normally visible to TV/EO sensors may be lost in the light clutter. Laser pointers will suffer the same type of degradation. TV/EO resolution is typically not sufficient at medium and extended ranges to discriminate between a friendly position or a target and its surrounding features. Ground personnel may need to utilize more aggressive and overt means of identifying their position and that of the target if TV/EO sensors are to be used to identify, track, and engage targets.

## **B-10. TASK FORCE S-3 AIR PLANNING REQUIREMENTS**

The following list is not all-inclusive but further defines the TF S-3 air planning requirements in support of aviation integration in the close fight. Many of these requirements require the assistance of the maneuver task force staff. Proper planning requires the integration of the brigade and its associated direct support aviation brigade headquarters or task force as early as possible in the MDMP.

a. Coordinate airspace usage and control with the TF S3, maneuver brigade S3, FSO, and ADA platoon leader.

b. Coordinate for land usage within the TF area of operations for possible forward assembly areas, holding areas, and forward arming and refueling points.

- c. Coordinate for SEAD.
- d. Ensure that the TF commander understands the number of aviation assets available and duration of coverage provided. If required to support the operation, begin coordination to ensure a FARP is available to support the mission.
- e. Provide the aviation unit with the most current update on the enemy situation, with additional emphasis on air defense assets.
- f. Provide the aviation unit with fire support assets (not just SEAD) available. Provide call signs, frequencies, priorities of targets, and any special instructions.
- g. Coordinate air routes into the TF AO and FLOT-crossing procedures in both directions if required (passage points [PPs], alternate PPs, crossing times, SEAD windows, altitudes, and airspeeds).
- h. Ensure that the TF commander is briefed on fighter management considerations.
- i. Coordinate for COMSEC, Have Quick sequences (through the ALO) and IFF fills. Ensure that changeover times are the same between supporting and supported units and that both elements understand the communications requirements, capabilities, and limitations of the other.
- j. Ensure method of target marking and friendly position marking is passed to aviation brigade LNO.
- k. Prepare a mission statement for the aviation attack unit to include the target, target location, and the expected results of the attack (destroy, attrit, disrupt, overmatch, or deny or delay avenue of approach).
- l. Designate an axis of advance, separate from the TF's axis, for each attack helicopter unit.
- m. Coordinate for establishment and protection of BPs or ABF positions. To take advantage of helicopter mobility, battle positions should be planned for rear and flank shots into engagement areas, if possible. LNOs should not attempt to pick individual firing positions but should use the guidelines in the acronyms BRASSCRAF and NORMA (Appendix A, FM 1-112) to select BPs in conjunction with the aviation brigade or task force staffs.
- n. Coordinate for fire control in engagement areas. Establish target priorities for attack helicopters. Inform the TF commander that by doctrine, the target priorities for any attack helicopter are (in order):
  - Immediate threat to self.
  - Immediate threat to platoon or company.
  - Immediate threat to other friendly forces.
  - Pre-established target priorities.
- o. Coordinate laser codes, especially when working with compatible nonaviation laser systems (Copperhead, GLAD, Pave Penny, Maverick, and laser-guided bombs).

### **B-11. ARMY AVIATION MANEUVER SUPPORT IN URBAN OPERATIONS**

Effective combined arms employment in UO requires that aviation and ground maneuver forces synchronize their operations by operating from a common perspective. This paragraph highlights some possible procedures that will aid in creating a common air-ground perspective.

- a. **General.** Army aviation's primary role during UO is the support of the shaping operations. Aviation operating on the urban periphery effectively enhances isolation,

reconnaissance, resupply, troop movement, evacuation, and support by fire for ground forces. Army aviation also enhances the combined arms team's ability to quickly and efficiently transition to new missions. Aviation forces normally avoid operations in urban terrain due to the high risk of being engaged by enemy forces in close proximity. When aviation forces cannot avoid urban areas during UO, special measures and thorough risk analysis must be conducted to minimize the associated dangers. The following framework is used to visualize urban operations.

(1) **Assess.** Identify the portion(s) of the urban area essential to mission success. Aviation forces provide reconnaissance capability, security to ground forces, movement of troops and supplies, and augmentation of communication and surveillance capabilities.

(2) **Shape.** Isolate those areas essential to mission success or avoid isolation while in the defense. In the offense, aviation forces attack to isolate the objective, move troops and supplies, enhance C2, conduct reconnaissance, and augment ground forces. In the defense, aviation forces act as a maneuver element to set the conditions for the main battle and prevent isolation.

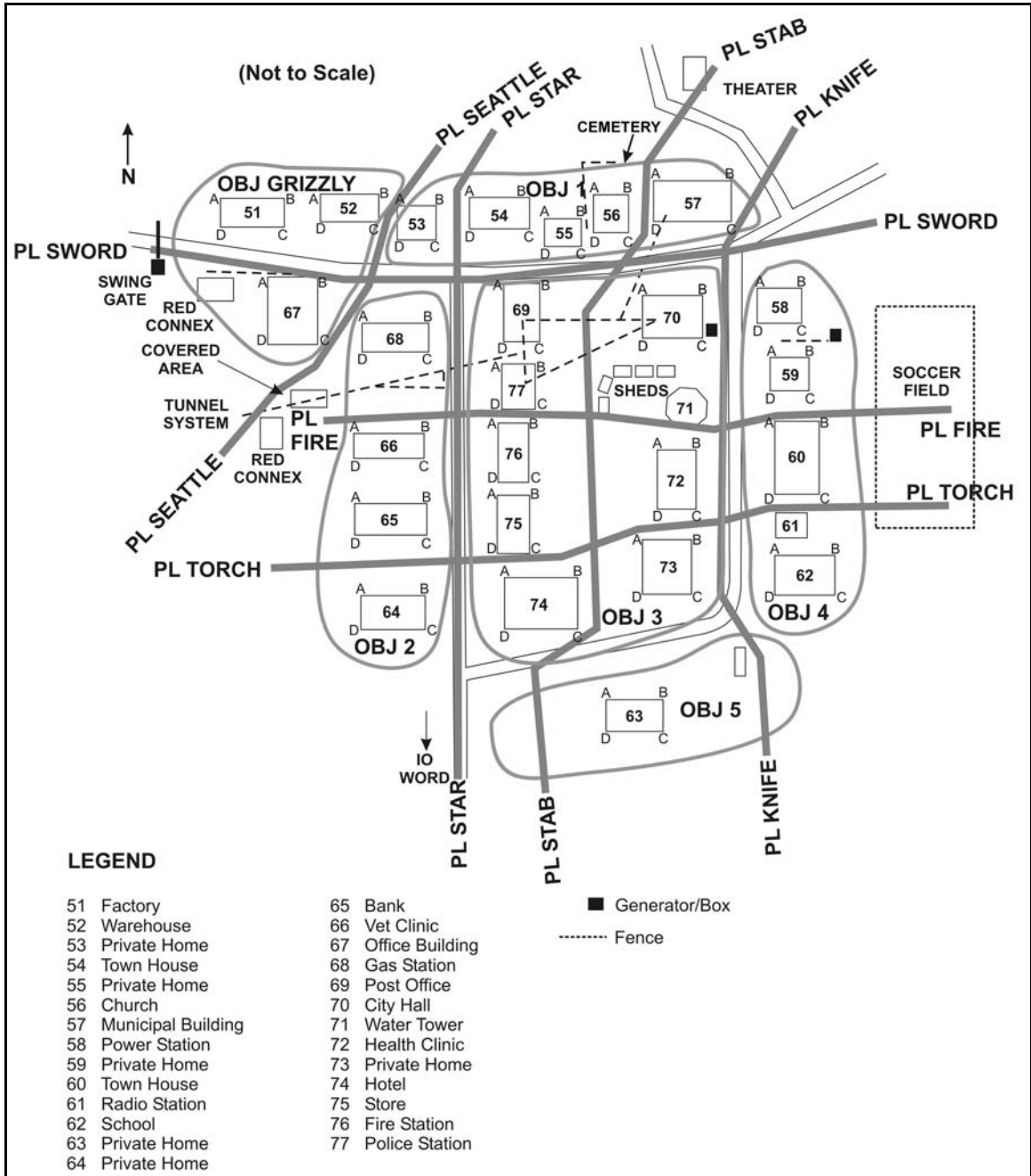
(3) **Dominate.** Precisely mass the effects of combat power to rapidly dominate the area. Army aviation supports the ground maneuver commander's intent and scheme of maneuver by providing maneuver and support assets. Aviation supports the combined arms effort by providing support by fire, movement of troops and supplies, enhanced C2, air assaults, reconnaissance, and continued isolation of the objective.

(4) **Transition.** Transition the urban area to the control of another agency and prepare for follow-on operations. Aviation forces conduct combat, combat support, and combat service support missions that facilitate the combined arms transition to follow-on operations.

b. **Command and Control.** Army aviation forces may be employed organic to a division or higher level of command to conduct maneuver or provide support (DS or GS). Aviation forces may also be attached or under operational control of another command. Operational control of attack helicopter units will remain at the level of battalion or higher; however, attack helicopters may conduct direct air-to-ground coordination with companies and platoons during combat operations.

c. **Maneuver Graphic Aids.** One of aviation's greatest strengths--its ability to maneuver three dimensionally--can also be a detriment. The associated challenge is that aircrews have different visual cues and perspectives than do ground forces. Common graphics and sketches can help alleviate these differences. A network route structure of air control points (ACP) and routes (preferably surveyed) may be used to facilitate route planning, navigation, and C3. Sketches help correlate air and ground control measures with predominate urban features. The area sketch offers the ground commander and the aircrew a means of identifying friendly and enemy locations for planning and coordination (Figure B-2). The area sketch is best used for smaller towns and villages but can be applied to a certain engagement area or specific area of operations in a larger city. The area sketch captures the natural terrain features, manmade features, and key terrain in that area and designates a letter or numeral code to each. Buildings are coded and each corner of the building is coded. This gives the aircrews an accurate way to target specific buildings as requested by the ground unit commander or to identify friendly locations. Inclusion of maneuver graphics, fire support control measures, and airspace control measures allows aircrews and maneuver elements to better visualize the urban portion of

the battlespace. Units must ensure they use the same area sketch for accurate coordination.



**Figure B-2. Area sketch (simplified).**

**d. Identifying Friendly Positions, Marking Locations, and Target Acquisition.**

In the urban environment friendly, enemy, and noncombatants may operate in close vicinity. Furthermore, structures and debris can cause problems with identifying precise locations. Reliable communication is essential to ensure aircrews know the locations of all participants in UO. To further enhance air-ground coordination, methods must be

established to allow aircrews to visually identify key locations. See Table B-5, page B-17, for methods of marking.

(1) **Targeting Grids and Reference Techniques.** Ground maneuver elements generally use a terrain-based reference system during urban operations. The military grid reference system (MGRS) coordinates have little meaning at street level. Common control methods include urban grid (Figure B-3), bull's-eye/checkpoint targeting (Figure B-4), objective area reference grid (Figure B-5), and TRPs (Figure B-6). These techniques are based on the street and structure pattern present, without regard to the MGRS grid pattern. Aircrews must plan to transition to the system in use by the ground element upon arrival in the objective area. For example, references to the objective or target may include local landmarks such as, "The third floor of the Hotel Caviar, southeast corner." This transition should be facilitated by using a "big to small" acquisition technique.

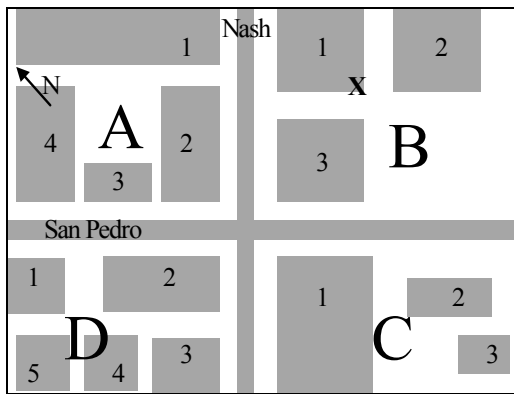


Figure B-3. Urban grid.

Bravo-1, south corner. Sniper top floor window."

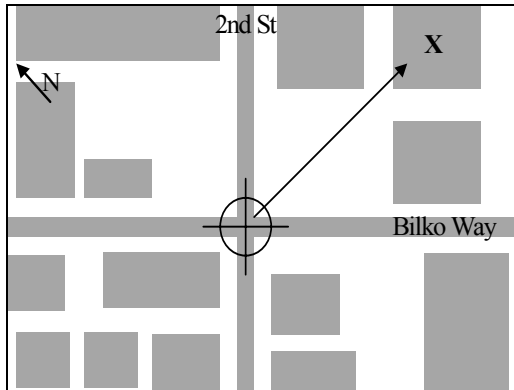
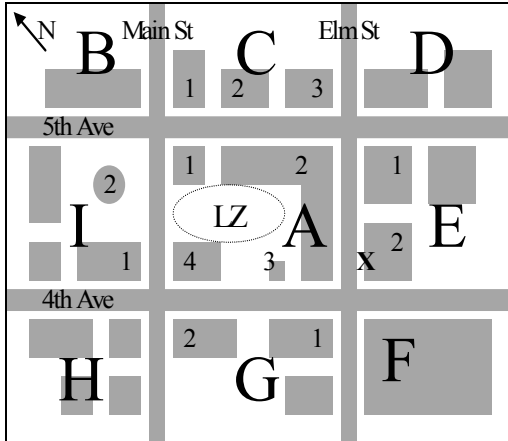


Figure B-4. Bull's-eye/Checkpoint targeting.

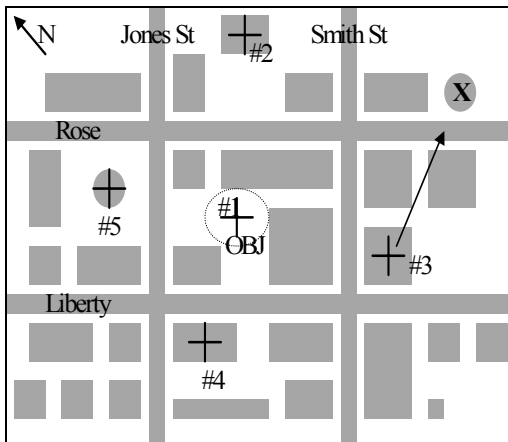
"Checkpoint, Charlie. 105 degrees magnetic, 250 meters, ZPU on the roof."





“Echo-2, main entry on Elm.”

**Figure B-5. Objective area reference grid.**



“TRP #3, 087 degrees magnetic, 325 meters, the water tower.”

**Figure B-6. TRP.**

(2) **Additional Cues.** Physical terrain features and visual markings provide additional guidance for identification purposes.

(a) **Roof Characteristics.** Flat roofs, pitched roofs, domed roofs, and roofs with towers or air conditioning units on top will aid in visual and thermal acquisition. Additional structural features revealed in imagery will aid in confirmation. This method of terrain association will prove invaluable for visual engagement or reconnaissance since structures are often too close for reliance on mere grid coordinates.

(b) **Visual Markings.** The visual signaling or marking of positions allows more ease in determining the location of friendly forces. During building clearing operations, the progress of friendly units (both horizontally and vertically) may be marked with spray paint or bed sheets hung out of windows. The simplest methods are often the best. Traditional signaling devices, such as flares, strobes, and signaling mirrors, may be effective as well. Target marking or an orientation on enemy positions may also be accomplished using signaling procedures. The use of GLINT tape, combat ID panels, and infrared beacons assist in the ID of friendly ground forces on urban terrain. Standardized usage of ground lighting, thermal contrast, and interposition of structures influence the effectiveness of these devices.

(c) *Shadows*. During both high and low ambient light conditions, expect to see significant urban shadowing from buildings when cultural lights are present. Shadows will hide personnel and or vehicular targets like the shadows that hide small hills against the background of larger mountains. Shadows will hide non-thermally significant targets, but thermal targets should still be seen. A combination of sensors will need to be used to acquire and identify the target; therefore, a sensor hand-off plan must be thoroughly briefed.

(d) *Global Positioning System*. The use of aircraft with integrated GPS will reduce the amount of time spent finding the target area. If ground forces can provide accurate coordinates, inputting a target grid into the GPS or INS will provide fire control cues (range, heading, time) to the target that will aid in quicker target acquisition and help distinguish friendly forces from enemy forces.

e. **Attack Helicopter Engagement**. Attack helicopters will conduct a variety of TTPs to engage targets in the urban area. Techniques range from support by fire and or attack by fire at maximum standoff ranges to running and or diving fire and close combat attack at minimum engagement ranges. Coordination is imperative to ensure positive ID of the target as well as friendly locations.

(1) Urban terrain introduces a unique challenge to aircrews and ground personnel alike with the notion of the urban canyon. Simply stated, an urban canyon exists when a target or target set is shielded by vertical structures. Unlike most natural terrain, the vertical characteristics of urban terrain can greatly affect delivery options. Urban terrain typically creates corridors of visibility running between structures. Street level targets are only visible along the street axis or from high angles. The interposition of structures around a target interrupts LOS from many directions. The presence of buildings and other structures in urban terrain creates corridors of visibility along streets, rivers, and railways. LOS must be maintained for enough time to acquire the target, achieve a weapons delivery solution, and fly to those parameters. This timeline is reduced during the employment of the AH-64D. A precise navigation system enables the aircraft to slave its sensors and weapons to a stored target, thereby significantly reducing target acquisition times. In some cases, the AH-64D may employ the gun or folding-fin aerial rockets (FFARs) in an “indirect” mode and never have to expose the aircraft to the target area. (Ground forces should make every attempt to pass along accurate 8-digit grid coordinates as the AH-64D can easily and accurately engage targets using this method.)

(2) Visibility limitations on marking devices in the urban environment are geometric in nature. The use of any pointer or laser requires LOS. In addition, the aircraft must have LOS with the target to see the mark. Urban terrain severely limits LOS opportunities. Due to the close proximity of structures to one another, there may be very narrow fields of view and limited axes of approach. The high number of reflective surfaces in an urban setting presents an additional challenge. Laser energy can be reflected and present multiple false returns. For these reasons, fire support can be expected to be more time consuming and much more dependent on good communications.

(3) Combinations of marking devices and clear talk-on procedures will be essential to safe and effective fire support. Ground forces should consider using buddy lasing or remote lasing tactics for laser guided munitions when urban effects preclude the attacking aircraft from maintaining LOS with the target until ordnance impact. However, if designating with a ground-based laser along a narrow street bounded by tall buildings,

LOS geometry may allow the weapon to receive reflected laser energy. Aircrews must also consider the potential miss distances for “precision” munitions when their guidance source is interrupted or removed.

(4) Armed helicopters can carry a mix of weapons. Commanders must choose the weapons to use on a specific mission based on their effects on the target, employment techniques, and the target's proximity to ground forces. Planners must consider proportionality, collateral damage, and non-combatant casualties. Planners and aircrew must consider the following when choosing weapons:

- Hard, smooth, flat surfaces with 90 degree angles are characteristic of man-made targets. Due to aviation delivery parameters, munitions will normally strike a target at an angle less than 90 degrees. This may reduce the effect of munitions and increase the chance of ricochets. The tendency of rounds to strike glancing blows against hard surfaces means that up to 25 percent of impact-fuzed rounds may not detonate when fired onto areas of rubble.
- Identification and engagement times are short.
- Depression and elevation limits create dead space. Target engagement from oblique angles, both horizontal and vertical, must be considered.
- Smoke, dust, and shadows mask targets. Additionally, rubble and man-made structures can mask fires. Targets, even those at close range, tend to be indistinct.
- Urban fighting often involves units attacking on converging routes. The risks from friendly fires, ricochets, and fratricide must be considered during the planning of operations.
- The effect of the weapon and the position of friendly and or enemy personnel with relation to structures must be considered. Choose weapons for employment based on their effects against the building material composition rather than against enemy personnel.
- Munitions can produce secondary effects, such as fires.

---

**APPENDIX C**  
**OPERATIONS IN NUCLEAR, BIOLOGICAL,  
AND CHEMICAL CONDITIONS**

*The purpose of using nuclear, biological, and chemical weapons is the same as for any other weapons: to produce casualties, destroy or disable equipment, and disrupt the enemy's operations. Chemical and biological agents and nuclear weapons may be employed separately or together and normally supplement conventional weapons. Planning must routinely address the use of each of these as well as protective measures against enemy NBC weapons.*

**Section I. NUCLEAR, BIOLOGICAL, CHEMICAL BATTLEFIELD**

The integration of NBC weapons and contamination caused by industrial incidents into tactical operations is described as the NBC-contaminated battlefield.

**C-1. COMMAND**

The task force commander prepares his units and personnel to operate in an NBC environment. To do this, he ensures the battalion task force takes the proper protective measures, including--

- NBC vulnerability analysis.
- Dispersion and use of terrain as shielding.
- Continuous NBC monitoring with detection equipment.
- Assumption of the appropriate MOPP level.

**C-2. STAFF**

For NBC operations, the battalion task force chemical officer provides technical advice to the TF commander and the remainder of the TF staff. The NBC staff officer--

- Templates strikes and develops predictions on the effects of enemy NBC weapons on TF operations in conjunction with the S2.
- Disseminates information received via the NBC warning and reporting system (NBCWRS).
- Recommends reconnaissance, monitoring, and surveying requirements.
- Recommends MOPP and operational exposure guidance based on the S2's threat analysis and higher headquarters guidance.
- Maintains records of unit contamination to include radiological dose records.
- Conducts vulnerability analysis of unit positions.
- Plans TF decontamination operations in conjunction with the S3.
- Coordinates for nonorganic NBC assets (decontamination, smoke, and reconnaissance) support.
- Acts as the liaison between attached chemical units and the S3.

**C-3. CHARACTERISTICS OF CHEMICAL AGENTS**

Chemical agents cause casualties, degrade performance, slow maneuver, restrict terrain, and disrupt operations (Table C-1). They can cover large areas and may be delivered as liquid, vapor, or aerosol and disseminated by artillery, mortars, rockets, missiles, aircraft spray, bombs, land mines, and covert means.

AGENT	Nerve	Blood	Blister	Choking
<b>PROTECTION</b>	Mask and BDO	Mask and BDO	Mask	Mask
<b>DETECTION</b>	M8A1, M256A1, CAM, M8 and M9 paper	M256A1, CAM, M8 and M9 paper	M256A1	Odor (freshly mowed hay)
<b>SYMPTOMS</b>	Difficult breathing, drooling, nausea, vomiting, convulsions, and blurred vision	Burning eyes, stinging skin, irritated nose	Convulsions and coma	Coughing, nausea, choking, headache, and tight chest
<b>EFFECTS</b>	Incapacitates	Blisters skin, damages respiratory tract	Incapacitates	Floods and damages lungs
<b>FIRST AID</b>	Mark 1 NAAK	As for 2d and 3d degree burns	None	Keep warm and avoid movement
<b>DECON</b>	M291 and flush eyes with water	M291 and flush eyes with water	None	None

**Table C-1. Characteristics of chemical agents.**

**C-4. CHARACTERISTICS OF BIOLOGICAL AGENTS**

a. **Toxins.** Toxins are poisonous substances produced from living organisms. The following are characteristics of toxins:

- Can be synthesized (artificially produced).
- Mirror the symptoms of nerve agents.
- Present 8-12 hours of tactical concern (some are changed by sunlight).
- Can be fast acting (neurotoxins) or slower acting (cytotoxins).

b. **Pathogens.** Pathogens are infectious agents that cause disease in man and animals, such as bacteria, viruses, and rickettsiae. The following are characteristics of pathogens:

- Delayed reaction (incubation 1-21 days).
- Multiply and overcome natural defenses.
- Inhalation is the primary mode of exposure.

c. **Protection from Biological Agents.** The following offer protection against biological agents:

- Up-to-date immunizations.
- Good hygiene.
- Area sanitation.
- Physical conditioning.
- Water purification.
- Food sanitation
- Use of chemoprophylaxis as directed.

### C-5. NUCLEAR WEAPONS EFFECTS

Nuclear weapons are much more destructive than conventional weapons. Blast, nuclear and thermal radiation, and electromagnetic pulse are of primary concern.

- a. **Blast.** High-pressure shock wave crushes structures and causes missing damage.
- b. **Thermal Radiation.** Intense heat and extremely bright light causes burns, temporary blindness, and dazzle.
- c. **Nuclear Radiation.** Energy released from a nuclear detonation produces fallout in the form of initial and residual radiation, both of which cause casualties.
- d. **Electromagnetic Pulse.** Surge of electrical power occurs within seconds of a nuclear detonation and damages electrical components in equipment (radios, radar, computers, and vehicles) and weapon systems (TOW, Javelin, and Dragon).
- e. **Protection from Nuclear Attack.** Cover/shielding offers the best protection from the immediate effects of a nuclear attack. This includes cover in fighting positions, culverts, and ditches. Soldiers should cover exposed skin and stay down until the blast wave passes and debris stops falling. Immediately after a nuclear attack, begin continuous radiation monitoring.
- f. **Monitoring.** FM 3-3 describes monitoring techniques, correlation factor data, and recording forms. Monitoring may be periodic or continuous.
  - (1) **Periodic.** Units conduct periodic monitoring during nuclear warfare. All units routinely (at least once an hour) monitor a designated point in their respective areas. The NBC defense annex of the unit SOP gives detailed guidance on monitoring procedures.
  - (2) **Continuous.** All units initiate continuous monitoring when they receive a fallout warning, when a unit is on an administrative or tactical move, when a nuclear burst occurs, when radiation levels above one centigray (cGy) per hour are detected by periodic monitoring, and on order of the commander. Continuous monitoring stops on instructions from the commander or higher headquarters or when the dose rate falls below one cGy per hour (except for units on the move).
- g. **Operational Exposure Guidance.** Operations in a nuclear environment are complicated by the necessity to control exposure of personnel to nuclear radiation. An OEG determines the maximum radiation dose to which units may be exposed and still accomplish a mission. Determination of this dose is based on the accumulated dose or radiation history of the unit.

## Section II. TENETS OF NUCLEAR, BIOLOGICAL, AND CHEMICAL DEFENSE

Protect the force by adhering to three tenets of NBC defense: contamination avoidance, protection, and decontamination.

### C-6. CONTAMINATION AVOIDANCE

Avoiding NBC attacks and hazards is the key to NBC defense. Avoidance allows commanders to shield soldiers and units.

- a. **Active and Passive Measures.** Contamination avoidance involves both active and passive measures. Passive measures include training, camouflage, concealment, hardening positions, and dispersion. Active measures include detection, reconnaissance, alarms and signals, warning and reporting, marking, and contamination control.

b. **NBC Reconnaissance.** NBC reconnaissance is the detection, identification, reporting, and marking of NBC hazards. NBC reconnaissance consists of search, survey, surveillance, and sampling operations. Due to limited availability of the M93 FOX reconnaissance vehicle, consider alternate means of conducting NBC reconnaissance (such as scouts, MPs, engineers, and maneuver units). As a minimum, consider the following actions when planning and preparing for NBC reconnaissance:

- Use the IPB process to orient on NAIs.
- Pre-position reconnaissance assets to support requirements.
- Establish command and support relationships.
- Assess the time and distance factors for the conduct of NBC reconnaissance.
- Report all information rapidly and accurately.
- Plan for resupply activities to sustain NBC reconnaissance operations.
- Determine possible locations for post-mission decontamination.
- Plan for fire support requirements.
- Plan fratricide prevention measures.
- Establish MEDEVAC procedures.
- Identify NBCWRS procedures and frequencies.

**C-7. NBC PROTECTION**

NBC protection is an integral part of operations. Techniques that work for avoidance also work for protection (shielding soldiers and units and shaping the battlefield). Other forms of protection involve sealing or hardening positions, protecting soldiers, assuming appropriate MOPP levels (Table C-2), reacting to attack, using pretreatments, barrier creams, and chemoprophylaxis, and using collective protection. Individual protective items include the protective mask, battledress overgarments (BDOs), overboots, and gloves. The corps or higher level commander establishes the minimum level of protection. Subordinate units may increase this level as necessary but may not decrease it. BDOs may be worn for 30 days in an uncontaminated environment or for 24 hours once contaminated.

<b>MOPP Levels</b>							
<i>Level Equip</i>	<b>MOPP Ready</b>	<b>MOPP 0</b>	<b>MOPP 1</b>	<b>MOPP 2</b>	<b>MOPP 3</b>	<b>MOPP 4</b>	<b>Mask Only</b>
<i>Mask</i>	Carried	Carried	Carried	Carried	Worn	Worn	Worn***
<i>BDO</i>	Ready*	Avail **	Worn	Worn	Worn	Worn	
<i>Overboots</i>	Ready*	Avail **	Avail **	Worn	Worn	Worn	
<i>Gloves</i>	Ready*	Avail **	Avail **	Avail **	Avail **	Worn	
<i>Helmet Cover</i>	Ready*	Avail **	Avail **	Worn	Worn	Worn	

\* Items avail to soldier within 2 hours w/replacement avail within 6 hours  
 \*\* Items must be positioned within arm's reach of the soldier  
 \*\*\* Never "mask only" if nerve or blister agent is used in AO

**Table C-2. MOPP levels.**

**C-8. DECONTAMINATION**

Use of NBC weapons creates unique residual hazards that may require decontamination. In addition to the deliberate use of these weapons, collateral damage, natural disasters,

and industrial emitters may require decontamination. Contamination forces units into protective equipment that degrades performance of individual and collective tasks. Decontamination restores combat power and reduces casualties that may result from exposure, thus allowing commanders to sustain combat operations. Use the four principals of decontamination when planning decontamination operations:

- Decontaminate as soon as possible.
- Decontaminate only what is necessary.
- Decontaminate as far forward as possible (METT-T dependent).
- Decontaminate by priority.

a. The three levels of decontamination are--

(1) **Immediate Decontamination.** Immediate decontamination requires minimal planning, and is a basic soldier survival skill. Personal wipedown removes contamination from individual equipment using the M291. For individuals unable to perform self-decontamination, buddy aid decontamination is performed. Operator spraydown uses the on-board decontamination apparatus with DS2 to decontaminate surfaces that an operator must touch or contact to operate the equipment.

(2) **Operational Decontamination.** Operational decontamination involves MOPP gear exchange and vehicle spraydown. MOPP gear exchange is most effective when performed within the first six hours of being contaminated; it must be completed within twenty-four hours of being contaminated. Vehicle washdown removes gross contamination and limits the spread of contamination.

(3) **Thorough Decontamination.** Thorough decontamination involves detailed troop decontamination (DTD) and detailed equipment decontamination (DED). Thorough decontamination is normally conducted as part of reconstitution or during breaks in combat operations. Support from a chemical decontamination platoon is required.

b. Decontamination planning considerations include the following:

- Plan decontamination sites throughout the width and depth of the sector.
- Tie decontamination sites to the scheme of maneuver and templated NBC strikes.
- Apply the principles of decontamination.
- Plan for contaminated routes.
- Plan logistics and resupply of MOPP, mask parts, water, and decontamination supplies.
- Consider medical concerns, including treatment and evacuation of contaminated casualties.
- Plan for site security.

c. **Patient Decontamination.** Patient decontamination is conducted at the battalion aid station or at the decontamination area. See FM 3-5 and FM 4-02.7 for detailed information. Non-medical personnel perform patient decontamination under medical supervision.



---

**APPENDIX D**

**RISK MANAGEMENT AND FRATRICIDE AVOIDANCE**

*The primary objective of risk management and fratricide avoidance is to help units protect their combat power through accident prevention, enabling them to win the battle quickly and decisively with minimum losses. This appendix focuses on two topics: risk management and the avoidance of fratricide. Risk is the chance of injury or death for individuals and of damage to or loss of vehicles and equipment. Risk, or the potential for risk, is always present in every combat and training situation. Risk management must take place at all levels of the chain of command during each phase of every operation; it is an integral part of planning. The battalion task force commander, company team commanders, staff, and all soldiers must know how to use risk management, coupled with fratricide avoidance measures, to ensure the TF executes the mission in the safest possible environment within mission constraints. (For additional information on risk management, refer to FM 100-14.)*

**Section I. RISK MANAGEMENT**

Risk management is the process of identifying and controlling hazards to conserve combat power and resources. Leaders (to include the staff) must always remember that the effectiveness of the process depends on never approaching risk management with “one size fits all” solutions to the hazards their units face. They must consider the essential tactical and operational factors that make each situation unique. There are five steps of risk management. This five-step process is integrated into the military decision-making process (Table D-1, page D-2).

Military Decision-Making Process	Risk Management Steps				
	Step 1 Identify Hazards	Step 2 Assess Hazards	Step 3 Develop Controls and Make Risk Decisions	Step 4 Implement Controls	Step 5 Supervise and Evaluate
Mission Receipt	X				
Mission Analysis	X	X			
COA Development	X	X	X		
COA Analysis	X	X	X		
COA Comparison			X		
COA Approval			X		
Orders Production				X	
Rehearsal <sup>1</sup>	X	X	X	X	X
Execution and Assessment <sup>1</sup>	X	X	X	X	X

<sup>1</sup> All boxes are marked to emphasize the continued use of the risk management process throughout the mission.

**Table D-1. Risk management steps correlated with MDMP tasks.**

**D-1. STEP 1, IDENTIFY HAZARDS**

A hazard is a source of danger. It is any existing or potential condition that could result in injury, illness, or death of personnel; damage to or loss of equipment and property; or some other form of mission degradation. Hazards arise in both tactical and training operations. Leaders must identify the hazards associated with all aspects and phases of the mission, paying particular attention to the factors of METT-TC. Risk management must never be an afterthought; leaders must begin the process during MDMP (troop-leading procedures for company team and below) and continue it throughout the operation. Table D-2 lists possible sources of risk the battalion task force might face during a typical tactical operation. The list is organized according to the factors of METT-TC.

<b>SOURCES OF BATTLEFIELD RISK</b>
<p><b>MISSION</b></p> <p>Duration of the operation.</p> <p>Complexity or clarity of the plan. (Is the plan well developed and easily understood?)</p> <p>Proximity and number of maneuvering units.</p>
<p><b>ENEMY</b></p> <p>Knowledge of the enemy situation.</p> <p>Enemy capabilities.</p> <p>Availability of time and resources to conduct reconnaissance.</p>
<p><b>TERRAIN AND WEATHER</b></p> <p>Visibility conditions, including light, dust, fog, and smoke.</p> <p>Precipitation and its effects on mobility.</p> <p>Extreme heat or cold.</p> <p>Additional natural hazards (broken ground, steep inclines, and water obstacles).</p>
<p><b>TROOPS AND SUPPORT AVAILABLE</b></p> <p>Equipment status.</p> <p>Morale.</p> <p>Experience units conducting the operation have working together.</p> <p>Soldier and leader proficiency.</p> <p>Soldier and leader rest situation.</p> <p>Degree of acclimatization to environment.</p> <p>Impact of new leaders and crewmembers.</p>
<p><b>TIME AVAILABLE</b></p> <p>Time available for planning and rehearsals.</p> <p>Time available to conduct the mission.</p>
<p><b>CIVIL CONSIDERATIONS</b></p> <p>Applicable ROE and ROI.</p> <p>Potential stability and support operations involving contact with civilians (such as NEOs, refugee or disaster assistance, or counterterrorism).</p> <p>Potential for media contacts or inquiries.</p>

**Table D-2. Examples of potential hazards.**

**D-2. STEP 2, ASSESS HAZARDS TO DETERMINE RISKS**

Hazard assessment is the process of determining the direct impact of each hazard on an operation (in the form of hazardous incidents).

- a. Determine which hazards can be eliminated or avoided.
- b. Assess each hazard that cannot be eliminated or avoided to determine the probability that the hazard will occur.
- c. Assess the severity of hazards that cannot be eliminated or avoided. Severity, defined as the result or outcome of a hazardous incident, is expressed by the degree of

injury or illness (including death), loss of or damage to equipment or property, environmental damage, or other mission-impairing factors (such as unfavorable publicity or loss of combat power).

d. Taking into account both the probability and severity of a hazard, determine the associated risk level (extremely high, high, moderate, or low). Table D-3 summarizes the four risk levels.

e. Based on the factors of hazard assessment (probability, severity, and risk level, as well as the operational factors unique to the situation), complete risk management worksheet. (Refer to FM 100-14 for an example of a completed risk management worksheet.)

RISK LEVEL	MISSION EFFECTS
Extremely high (E)	Mission failure if hazardous incidents occur in execution.
High (H)	Significantly degraded mission capabilities in terms of required mission standards. Not accomplishing all parts of the mission or not completing the mission to standard (if hazards occur during mission).
Moderate (M)	Expected degraded mission capabilities in terms of required mission standards. Reduced mission capability (if hazards occur during the mission).
Low (L)	Expected losses have little or no impact on mission success.

**Table D-3. Risk levels and impact on mission execution.**

**D-3. STEP 3, DEVELOP CONTROLS AND MAKE RISK DECISIONS**

Step 3 consists of two substeps: develop controls and make risk decisions. This step is done during the COA development, COA analysis, COA comparison, and COA approval steps of the military decision-making process.

a. **Develop Controls.** Controls are the procedures and considerations the unit uses to eliminate hazards or reduce their risk. After assessing each hazard, develop one or more controls that will either eliminate the hazard or reduce the risk (probability, severity, or both) of potential hazardous incidents. When developing controls, consider the reason for the hazard, not just the hazard itself.

b. **Make Risk Decisions.** A key element in the process of making a risk decision is determining whether accepting the risk is justified or, conversely, is unnecessary. The decision-maker must compare and balance the risk against mission expectations, then decide if the controls are sufficient and acceptable and whether to accept the resulting residual risk. If the risk is determined unnecessary, the decision-maker directs the development of additional controls or alternative controls; as another option, he can modify, change, or reject the selected COA for the operation.

**D-4. STEP 4, IMPLEMENT CONTROLS**

Implementing controls is the most important part of the risk management process. It is the chain of command’s contribution to the safety of the unit. Implementing controls includes coordination and communication with appropriate superior, adjacent, and

subordinate units and with individuals executing the mission. The TF commander must ensure that specific controls are integrated into OPLANs, OPORDs, SOPs, and rehearsals. The critical check for this step is to ensure that controls are converted into clear, simple execution orders understood by all levels. If the leaders have conducted a thoughtful risk assessment, the controls will be easy to implement, enforce, and follow. Examples of risk management controls include the following:

- Thoroughly brief all aspects of the mission, including related hazards and controls, and ensure that subordinates know the plan.
- Allow adequate time for rehearsals at all levels.
- Drink plenty of water, eat well, and get as much sleep as possible (at least 4 hours in any 24-hour period).
- Enforce speed limits, use of seat belts, and driver safety.
- Establish recognizable visual signals and markers to distinguish maneuvering units.
- Enforce the use of ground guides in assembly areas and on dangerous terrain.
- Limit single-vehicle movement.
- Establish SOPs for the integration of new personnel.

#### **D-5. STEP 5, SUPERVISE AND EVALUATE**

During mission execution, leaders must ensure their subordinates properly understand and execute risk management controls. Leaders must continuously evaluate the unit's effectiveness in managing risks to gain insight into areas that need improvement.

a. **Supervision.** Leadership and unit discipline are the keys to ensuring implementation of effective risk management controls. All leaders are responsible for supervising mission rehearsals and execution to ensure standards and controls are enforced. In particular, NCOs must enforce established safety policies as well as controls developed for a specific operation or task. Techniques include spot checks, inspections, SITREPs, confirmation briefs, and supervision. During mission execution, leaders must continuously monitor risk management controls to determine whether they are effective and to modify them as necessary. Leaders must also anticipate, identify, and assess new hazards. They ensure that imminent danger issues are addressed on the spot and that ongoing planning and execution reflect changes in hazard conditions.

b. **Evaluation.** Whenever possible, the risk management process should also include an after-action review to assess unit performance in identifying risks and preventing hazardous situations. Leaders should then incorporate lessons learned from the process into unit SOPs and plans for future missions.

c. **Commander's Guidance.** The TF commander gives the company team commanders and staff direction, sets priorities, and establishes the command climate (values, attitudes, and beliefs). Successful preservation of combat power requires him to imbed risk management into individual behavior. To fulfill this commitment, the commander must exercise creative leadership, innovative planning, and careful management. Most importantly, he must demonstrate support for the risk management process. The commander and others in the chain of command can establish a command climate favorable to risk management integration by taking the following actions:

- Demonstrating consistent and sustained risk management behavior through leading by example and stressing active participation throughout the risk management process.
- Providing adequate resources for risk management. Every leader is responsible for obtaining the assets necessary to mitigate risk and for providing them to subordinate leaders.
- Understanding their own and their soldier's limitations, as well as their unit's capabilities.
- Allowing subordinates to make mistakes and learn from them.
- Preventing a "zero defects" mindset from creeping into the unit's culture.
- Demonstrating full confidence in subordinates' mastery of their trades and their ability to execute a chosen COA.
- Keeping subordinates informed.
- Listening to subordinates.

d. **Leader Responsibility.** For the commander, his subordinate leaders, and individual soldiers alike, responsibilities in managing risk include the following:

- Make informed risk decisions; establish and then clearly communicate risk decision criteria and guidance.
- Establish clear, feasible risk management policies and goals.
- Train the risk management process. Ensure that subordinates understand the who, what, when, where, and why of managing risk and how these factors apply to their situation and assigned responsibilities.
- Accurately evaluate the unit's effectiveness, as well as subordinates' execution of risk controls during the mission.
- Inform higher headquarters when risk levels exceed established limits.

## **Section II. FRATRICIDE AVOIDANCE**

Fratricide avoidance is a complex problem defying simple solutions. Fratricide can be defined broadly as employing friendly weapons and munitions with the intent of killing the enemy or destroying his equipment or facilities but resulting in unforeseen and unintentional death or injury to friendly personnel. This section focuses on actions leaders can take to reduce the risk and occurrence of fratricide using current resources.

### **D-6. MAGNITUDE OF THE PROBLEM**

The modern battlefield is more lethal than any in history. The tempo of operations is rapid, and the nonlinear nature of the battlefield creates command and control challenges for unit leaders. The accuracy and lethality of modern weapons make it possible to engage and destroy targets at extended ranges. However, the ability of US forces to acquire targets using thermal imagery and other sophisticated sighting systems exceeds its capability to identify these targets accurately. Consequently, friendly elements can be engaged unintentionally and destroyed in a matter of seconds. Added to this is battlefield obscuration, which becomes a critical consideration whenever thermal sights are the primary source of target identification. Rain, dust, fog, smoke, and snow degrade identification capability by reducing the intensity and clarity of thermal images. On the battlefield, positive visual identification cannot be the sole engagement criteria at ranges

beyond 1,000 meters. The common operational picture is essential and must be maintained throughout any operation.

#### **D-7. RISK IDENTIFICATION AND PREVENTIVE MEASURES**

Reduction of fratricide risk begins during the planning phase of an operation and continues through preparation and execution. Risk identification must be conducted at all levels during each phase, and the results clearly communicated up and down the chain of command, so risk assessment can begin. The following paragraphs cover considerations influencing risk identification and focuses on measures the leader can implement to make the identification process more effective and help prevent friendly fire incidents from occurring.

#### **D-8. PLANNING PHASE**

A thoroughly developed, clearly communicated, and completely understood plan helps minimize fratricide risk. The following factors affect the potential for fratricide in a given operation:

- Clarity of the enemy situation.
- Clarity of the friendly situation.
- Clarity of the commander's intent.
- Complexity of the operation.
- Planning time available at each level.

Graphics are a basic tool commanders at all levels use to clarify their intent, add precision to their concept, and communicate their plan to subordinates. Graphics can be a very useful tool in reducing the risk of fratricide. Each commander must understand the definitions and purposes of operational graphics and the techniques of their employment. (See FM 101-5-1 for the definitions of each type of graphic control measure.)

#### **D-9. PREPARATION PHASE**

Confirmation briefs and rehearsals are primary tools for identifying and reducing fratricide risk during the preparation phase. The following are considerations for their use:

- a. Confirmation briefs and rehearsals ensure subordinates know where fratricide risks exist and what to do to reduce or eliminate them.
- b. Briefbacks ensure subordinates understand the commander's intent. They often highlight areas of confusion or complexity, or planning errors.
- c. The type of rehearsal conducted determines the types of risks identified.
- d. Rehearsals should extend to all levels of command and involve all key players.
- e. The following factors may reveal fratricide risks during rehearsals:
  - Number and type of rehearsals.
  - Training and proficiency levels of units and individuals.
  - The habitual relationships between units conducting the operation.
  - The physical readiness (endurance) of the troops conducting the operation.

### **D-10. EXECUTION PHASE**

During execution, in-stride risk assessment and reaction can overcome unforeseen fratricide risk situations.

- a. The following are factors to consider when assessing fratricide risks:
  - Intervisibility between adjacent units.
  - Amount of battlefield obscuration.
  - Ability or inability to identify targets positively.
  - Similarities and differences in equipment, vehicles, and uniforms between friendly and enemy forces.
  - Vehicle density on the battlefield.
  - The tempo of the battle.
- b. Maintaining the COP at all levels and at all times is another key to fratricide reduction as an operation progresses. Units develop and employ effective techniques and SOPs to aid leaders and crewmen in this process, to include--
  - Monitoring the next higher radio net.
  - Radio cross-talk between units.
  - Accurate position reporting and navigation.
  - Training, use, and exchange of liaison officers.

### **D-11. FRATRICIDE REDUCTION MEASURES**

The following measures provide a guide to actions that can reduce fratricide risk. Use of these measures is not required, and they are not intended to restrict initiative. Apply them as appropriate based on the specific situation and METT-TC factors:

- a. Identify and assess potential fratricide risks in the estimate of the situation. Express these risks in the OPORD or FRAGO.
- b. The unit leadership must focus on areas such as current intelligence, unit locations and dispositions, denial areas (minefields and FASCAM), contaminated areas such as ICM and NBC, SITREPs, and METT-TC factors.
- c. Ensure positive target identification. Review vehicle and weapon ID cards. Know at what ranges and under what conditions positive identification of friendly vehicles and weapons is possible.
- d. Establish a command climate that stresses fratricide prevention. Enforce fratricide prevention measures and emphasize the use of doctrinally sound tactics, techniques, and procedures. Ensure constant supervision in the execution of orders and the performance of all tasks and missions to standard.
- e. Recognize the signs of battlefield stress. Maintain unit cohesion by taking quick, effective action to alleviate it.
- f. Conduct individual, leader, and collective (unit) training covering fratricide awareness, target identification and recognition, and fire discipline.
- g. Develop a simple, decisive plan.
- h. Give complete and concise mission orders.
- i. Use SOPs that are consistent with doctrine to simplify mission orders. Periodically review and change SOPs as needed.
- j. Strive for maximum planning time for you and your subordinates.



- k. Use common language and vocabulary and doctrinally correct standard terminology and control measures, such as fire support coordination line, zone of engagement, and restrictive fire lines.
- l. Ensure thorough coordination is conducted.
- m. Plan for and establish effective communications (to include visual).
- n. Plan for collocation of command posts whenever it is appropriate to the mission, such as during a passage of lines.
- o. Designate and employ LNOs as appropriate.
- p. Ensure rules of engagement are clear.
- q. Include fratricide risk as a key factor in terrain analysis (OCOKA).
- r. Conduct rehearsals whenever the situation allows time to do so.
- s. Be in the right place at the right time. Use position location and navigation devices (GPS and position navigation [POSNAV]); know your location and the locations of adjacent units (left, right, leading, and follow-on) through use of FBCB2 and other means. Synchronize tactical movement.
- t. Plan and brief OPSEC, especially when utilizing dismounted operations (challenge and password, sign and countersign).
- u. Include discussion of fratricide incidents in AARs.
- v. Ensure fire commands are accurate, concise, and clearly stated. Make it mandatory for soldiers to ask for clarification of any portion of the fire command that they do not completely understand.
- w. Stress the importance of the chain of command in the fire control process; ensure soldiers get in the habit of obtaining target confirmation and permission to fire from their leaders before engaging targets they assume are enemy elements.
- x. Know who will be in and around the area of operations.

#### **D-12. FRATRICIDE RISK CONSIDERATIONS**

Table D-4, which parallels the five-paragraph OPORD, contains key factors and considerations in fratricide prevention. This is not a change to the OPORD format, but is a guide for use during OPORD development to ensure fratricide prevention measures are included. It is not a strict directive. The factors and considerations are listed where they would likely appear in the OPORD, but they may warrant evaluation during preparation of other paragraphs.

##### **Task Organization:**

- Has the unit worked under this task organization before?
- Are SOPs compatible with the task organization (especially with attached units)?
- Are special markings or signals (for example, cats' eyes, chemlites, or panels) needed for positive identification of uniforms and equipment?
- What special weapons and equipment are to be used? Do they look or sound like enemy weapons and equipment?

**Table D-4. Fratricide prevention checklist.**

**1. Situation.****a. Enemy Forces.****(1) Weather:**

- What are the expected visibility conditions (light data and precipitation) for the operation?
- What effects will rain, heat, and cold have on soldiers, weapons, and equipment?

**(2) Terrain:**

- Do you know the topography and vegetation (urban, mountainous, hilly, rolling, flat, desert, swamp/marsh, prairie/steppe, jungle, or open woods) of the expected AO?
- Have you evaluated the terrain using the factors of OCOKA?

**b. Friendly Forces.**

- Among the allied forces, are there differences (or similarities with enemy forces) in language, uniform, and equipment that could increase fratricide risk during combined operations?
- Could differences in equipment and uniforms among US armed forces increase fratricide risk during joint operations?
- What differences in equipment and uniforms can leaders stress to help prevent fratricide?
- What is the friendly deception plan?
- What are the locations of your unit and adjacent units (left, right, leading, and follow-on)?
- What are the locations of neutrals and noncombatants?
- What are the locations of your own forces?
- What is the status of training activities?
- What are the levels of individual, crew, and unit proficiency?
- Will fatigue be a factor for friendly forces during the operation? Has an effective sleep plan been developed?
- Are friendly forces acclimatized to the AO?
- What is the age (new, old, or mixed) and condition of equipment in friendly units?
- What is the status of new equipment training?
- What are the expected MOPP requirements for the operation?

**c. Attachments and Detachments.**

- Do attached elements understand pertinent information regarding enemy and friendly forces?
- Will gaining units provide this pertinent information to detached elements?
- Are communications systems compatible (digital/analog)?

**2. Mission.** Do all elements clearly understand the mission and all associated tasks and purposes?**Table D-4. Fratricide prevention checklist (continued).**

### 3. Execution.

#### a. *Concept of the Operation.*

(1) *Maneuver*: Are main and supporting efforts identified?

(2) *Fires (Direct and Indirect)*:

- Are priorities of fires identified?
- Have target lists been developed?
- Have the fire execution matrix and overlay been developed?
- Have locations of denial areas (minefields and FASCAM) and contaminated areas (ICM and NBC) been identified?
- Are the locations of all supporting fire targets identified in the OPORD and OPLAN overlays?
- Are aviation and CAS targets clearly identified?
- Has the direct fire plan been developed?
- Have FPFs been designated?
- Are the requirements for accurate predicted fire met or do we have to adjust fire?

(3) *Engineer Tasks*:

- Are friendly minefields, including FASCAM and ICM dud-contaminated areas, known?
- Have obstacles and the approximate time needed for reduction or breaching of each been identified?

(4) *Tasks to Each Subordinate Unit*: Are friendly forces identified, as appropriate, for each subordinate maneuver element?

(5) *Tasks to CS and CSS Units*: Have locations of friendly forces been reported to CS and CSS units?

#### b. *Coordinating Instructions.*

- Will rehearsals be conducted? Are they necessary? Are direct and indirect fires included?
- Is a confirmation brief necessary?
- Are appropriate control measures clearly explained and illustrated in the OPORD and overlays? Have they been disseminated to everyone who has a need to know? What is the plan for using these control measures to synchronize the battle and prevent fratricide?
- Are the locations for division and corps slice elements in the brigade battle space posted and disseminated?
- Have target and vehicle identification drills been practiced?
- Do subordinate units know the immediate action, drill, or signal for “CEASE FIRE” and “I AM FRIENDLY” if they come under unknown or friendly fire? Is there a backup?
- Is guidance in handling dud munitions, such as ICM and cluster bomb units (CBU), included?

**Table D-4. Fratricide prevention checklist (continued).**

4. **Service Support.**
  - Does everyone know trains locations and identification markings?
  - Do medical and maintenance personnel know the routes between train units?
5. **Command and Signal.**
  - a. **Command.**
    - What are the locations of the commander and key staff members?
    - What are the chain of command and the succession of command?
  - b. **Signal.**
    - Do instructions include backup code words and visual signals for all special and emergency events?
    - Do instructions cover how to identify friendly forces to aircraft?
    - Do they include backup code words and visual signals for all special and emergency events?
    - Are SOI distributed to all units with a need to know, such as higher, lower, adjacent, leading, and follow-on elements?

**Table D-4. Fratricide prevention checklist (continued).**

### **Section III. CONTINUOUS OPERATIONS**

The battalion task force often operates for extended periods of time in continuous operations. Continuous operations are combat operations continuing at the same high intensity level for extended periods. (For more information on the effects of continuous operations refer to FM 6-22.5.) Leaders and soldiers may have opportunities for sleep, but this sleep may be brief or fragmented and there likely will be periods of sustained operations characterized by very little opportunity for leaders and soldiers to get more than a few minutes of sleep. This continuous cycle of day and night operations and the associated stress of combat cause degradation in performance over time. Reducing this impact on performance is a significant challenge for the C2 system.

#### **D-13. EFFECTS OF CONTINUOUS OPERATIONS**

Continuous operations force leaders and soldiers to perform under adverse conditions that cause degradation in performance. The most significant factor leading to this degradation is the loss of sleep. Table D-5 shows the effects of sleep loss. Other contributing factors include low light levels, limited visibility, disrupted sleep routines, physical fatigue, and stress.

<b>AFTER 24 HOURS</b>	A deterioration in performance of tasks that are inadequately or newly learned, that are monotonous, or that require vigilance.
<b>AFTER 36 HOURS</b>	A marked deterioration in ability to register and understand information.
<b>AFTER 72 HOURS</b>	Performance on most tasks will be about 50 percent of normal.
<b>3 TO 4 DAYS</b>	The limit for intensive work including mental and physical elements. Visual illusions are likely at this stage, or earlier, especially in NBC.
<b>BETWEEN 0300 &amp; 0600 HOURS</b>	Performance is at its lowest ebb.

**Table D-5. Effects of sleep loss.**

**D-14. INDICATORS OF SLEEP DEPRIVATION AND FATIGUE**

To minimize the effects of sleep loss, all commanders must be able to recognize the signs of sleep loss and fatigue. Table D-6 shows the indicators of sleep deprivation and fatigue.

<b>PHYSICAL CHANGES</b>	Body swaying when standing. Vacant stares. Pale skin. Slurred speech. Bloodshot eyes.
<b>MOOD CHANGES</b>	Less energetic, alert, and cheerful. Loss of interest in surroundings. Possible depressed mood or apathetic and more irritable.
<b>EARLY MORNING DOLDRUMS</b>	Requires more effort to do a task in the morning than in the afternoon, especially between 0300 and 0600.
<b>COMMUNICATION PROBLEMS</b>	Unable to carry on a conversation. Forgetfulness. Difficulty in speaking clearly.
<b>DIFFICULTY PROCESSING INFORMATION</b>	<b>IN</b> Slow comprehension and perception. Difficulty in accessing simple situations. Requiring longer to understand information.
<b>IMPAIRED ATTENTION SPAN</b>	Decreased vigilance. Failure to complete routines. Reduced attention span. Short-term memory loss. Inability to concentrate.

**Table D-6. Indicators of sleep deprivation and fatigue.**

**D-15. REDUCING THE IMPACT OF CONTINUOUS OPERATIONS**

Table D-7 shows the measures that may reduce the negative impacts of continuous operations.

<b>SLEEP SCHEDULING</b>		<b>COUNTERMEASURES</b>
<b>ADEQUATE</b>	4 hours of continuous sleep in every 24 hours (likely to maintain adequate performance over several weeks).	Give simple, precise orders. Increase use of written orders. Crosscheck. Plan more time for completion of all tasks. Enforce adequate food and water intake. Develop and enforce sleep plans. Good physical fitness slows the effects of sleep loss and fatigue. Increase use of confirmation briefs.
<b>SLEEP WAKEFULNESS</b>	A small amount of sleep relative to that lost is beneficial.	
<b>RECOVERY</b>	10 hours uninterrupted sleep required for full recovery after 48-72 hours without sleep.	
<b>CATNAPS (10 TO 30 MINUTES)</b>	Catnaps are beneficial, but the only truly effective remedy is sleep.	
<b>TIMING</b>	Consistent timing of sleep and wakeup times will contribute to successful adjustment to an arduous regimen.	
<b>NOTE:</b> After 48-72 hours without sleep, soldiers become militarily ineffective. After 5 to 7 days of partial sleep deprivation, alertness and performance decline to the same low level as seen following 2 to 3 days without sleep.		

**Table D-7. Reducing the impact of continuous operations.**

**D-16. SLEEP DENIAL**

Commanders and leaders often regard themselves as being the least vulnerable to fatigue and the effects of sleep loss. Tasks requiring quick reaction, complex reasoning, and detailed planning, however, make leaders the most vulnerable to the effects of sleep deprivation. Leaders must sleep. The display of sleep denial as an example of self-control by leaders is extremely counterproductive.

## APPENDIX E

### ENVIRONMENTAL CONCERNS AND COMPLIANCE

*Preparation to conduct operations, in any environment, can incorporate the necessary environmental awareness with minimal additional planning. Many aspects of environmental protection discussed below will appear to be common sense and will most likely be a part of the task force's standing operational activity. This appendix will be a guide by which to attain a balance between mission accomplishment and protecting environmentally sensitive areas.*

#### **E-1. PREPARATION**

Advanced preparation is key to successful mission completion, and the same holds true for environmental awareness and protection. The task force commander should be aware of the publications governing environmental protection. All task force staffs (company and above) should designate an environmental compliance officer/NCO to serve as the unit's POC. This person will be responsible for environmental education, SOP updates, preparation of environmental risk assessments, and incident reporting. Commanders should refer to FM 3-100-4 for guidelines and procedures for applying risk management to identify actions that may harm the environment and steps that can be taken to minimize or prevent damage.

**NOTE:** FM 3-100.4 gives specific guidance on environmental protection and the task force commander should ensure compliance with that guidance. This appendix is intended to supplement, not replace, FM 3-100.4.

#### **E-2. CONDUCT OF THE MISSION**

Protecting the environment is always difficult and protecting the environment while conducting operations against a hostile force is not always possible. The task force must deploy and operate with minimal environmental damage. Commanders must initiate environmental control measures and establish appropriate protection levels without detracting from mission accomplishment. Environmental concerns pertaining to a mission should be incorporated into the mission briefing based on the factors of METT-TC (Table E-1, page E-2). Some of the factors affecting the briefing include mission, geographical location, and time of the year.

<b>MISSION</b>
1. Identify and assess known environmental risks during planning.
2. Determine environmental impact on mission execution.
3. Specify those areas to avoid and minimize the effect on the unit's scheme of maneuver.
4. Provide maps and or sketches with detailed areas of environmental concern.
5. Emphasize the importance of every soldier playing an active role in the identification and timely reporting of new environmental risk elements.
6. Rapidly and effectively respond to all hazardous waste accidents.
<b>ENEMY</b>
1. Identify areas of probable environmental contamination that could effect friendly force movement.
2. Evaluate intelligence reports of enemy equipment and or capability and how it could be employed against the environment.
3. Develop enemy target options to minimize environmental effects.
4. Maneuver enemy action away from environmentally sensitive areas, when feasible.
<b>TERRAIN AND WEATHER</b>
1. Provide recommended paths of movement to avoid environmentally sensitive areas.
2. Emphasize navigation accuracy and identify well defined terrain features.
3. Obtain and analyze predominant and developing weather patterns to diminish possible environmental risks.
<b>TROOPS AND EQUIPMENT AVAILABLE</b>
1. Develop a briefing for all soldiers that highlights and defines the environmental concerns and points of interest.
2. Provide a detailed and accurate SOP that identifies guidelines for avoiding risk areas while allowing for mission accomplishment.
3. Anticipate areas of probable risk and brief soldiers on how to prevent damage.
4. Incorporate environmental risk scenarios into rehearsals, if possible, to reinforce soldier response and promote the decision-making process to changing environmental risks.
5. Require accurate and timely reports that pertain to any environmental issues, friendly or enemy.
<b>TIME</b>
1. Maximize planning time and minimize complexity of mission brief.
2. Rehearse various mission profiles that emphasize adjusting for changing environmental factors while maintaining the desired momentum.
<b>CIVIL CONSIDERATIONS</b>
1. Avoid unnecessary damage and limit environmental impact to civil infrastructure due to the collateral damage of task force operations.
2. Determine how proposed task force actions will affect the civilian population in order to determine the "proportionality" of the environmental effects versus the mission benefit.
3. Evaluate what civil environmental factors the enemy may consider his HVTs and integrate this information into the plan.

**Table E-1. Environmental risks based on factors of METT-TC.**



**E-3. RISK ASSESSMENT**

The environmental risk assessment considerations contained in this appendix address the potential impact of the task force’s mission on the environment. The task force commander adds other considerations to address local conditions or different mission activities. Using a scale of “0” (no probability of environmental damage) to “5” (extremely high probability of environmental damage), he rates the specific activities the task force will perform during an operation. The commander performs this evaluation for each of seven environmental areas. Using sound judgment, the commander considers the conditions under which the task force will operate. He then applies this value to the risk assessment matrix. Figure E-1 is an example of a risk assessment matrix and is formatted to allow local reproduction, as required. Refer to Figure E-2, page E-5, for an example of a completed matrix for the environmental area of air pollution. The values assigned are not absolute; different commanders will assign different ratings for the same activity--it is a judgment call based on the commander’s assessment.

ENVIRONMENTAL AREA:		RATING					
UNIT ACTIVITY	RISK IMPACT						
	(CIRCLE ONE NUMBER IN EACH ROW.)						
MOVEMENT OF HEAVY VEHICLES AND SYSTEMS	5	4	3	2	1	0	
MOVEMENT OF PERSONNEL AND LIGHT VEHICLES/SYSTEMS	5	4	3	2	1	0	
ACTIVITIES OF ASSEMBLY-AREA	5	4	3	2	1	0	
FIELD MAINTENANCE OF EQUIPMENT	5	4	3	2	1	0	
MAINTENANCE CONDUCTED IN LOCALLY CONSTRUCTED MAINTENANCE FACILITIES WITH HARD STAND	5	4	3	2	1	0	

**Figure E-1. Risk assessment matrix.**

**E-4. ENVIRONMENTAL FACTORS**

Knowledge of environmental factors is key to planning and decision-making. With this knowledge, the task force commander can quantify risks, detect problem areas, reduce risk of injury or death, reduce property damage, and ensure compliance with environmental regulations. He should complete environmental risk assessments before conducting operations or logistical activities. The environmental risk assessment matrix provides a deliberate approach to assessing the risk posed by task force mission activities on specific environmental areas. (Figure E-2, page E-5, shows an example of a risk assessment for air pollution.) The matrix has four components:

- Environmental area.
- Task force mission activities.
- Risk impact.
- Risk rating.

#### **E-5. ENVIRONMENTAL AREAS**

The risk assessment matrix assesses risk in seven environmental areas. The task force commander and staff should develop one matrix for each. These areas are--

- Air pollution.
- Archeological, cultural, and historical resources.
- Hazardous materials and hazardous waste.
- Noise pollution.
- Threatened and endangered species.
- Water pollution.
- Soil, vegetation, and wetland protection.

#### **E-6. TASK FORCE MISSION ACTIVITIES**

The risk assessment matrix used in this manual considers five task force activities. These activities are generic, and the task force may modify them to meet its mission requirements and local conditions. These missions are--

- Movement of heavy vehicles and systems.
- Movement of personnel and light vehicles and systems.
- Activities of the assembly area.
- Field maintenance of equipment.
- Maintenance in locally constructed maintenance facilities with hard stand.

Examples of other activities the task force might add are--

- Direct and indirect weapons firing.
- Unexploded ordnance (UXO) operations.
- Aviation support and operations.
- Medical support and operations.
- Mines and demolition.
- Obscurant operations.
- Waterborne or amphibious operations.
- Limited visibility operations.
- NBC operations.

#### **E-7. RISK IMPACT VALUE**

The risk impact value estimates the probability that the task force's mission will have a negative impact on a particular environmental area. It is a judgment for which the numeric value (0-5) most closely reflects the conditions under which the task force is operating. The value is not an absolute, and different commanders might assign different values for the same mission. The risk impact value is a judgment call based on the assessment of the potential for environmental damage. The criteria shown in Tables E-2 through E-8, pages E-8 through E-

14, help commanders evaluate the probability of occurrence. In filling out the matrix, the commander or staff officer circles the value selected for each operation (Figure E-2).

ENVIRONMENTAL AREA: <b>AIR POLLUTION</b>			RATING <b>15</b>			
UNIT ACTIVITY	RISK IMPACT					
	(CIRCLE ONE NUMBER IN EACH ROW.)					
MOVEMENT OF HEAVY VEHICLES AND SYSTEMS	5	4	3	2	1	0
MOVEMENT OF PERSONNEL AND LIGHT VEHICLES/SYSTEMS	5	4	3	2	1	0
ACTIVITIES OF ASSEMBLY-AREA	5	4	3	2	1	0
FIELD MAINTENANCE OF EQUIPMENT	5	4	3	2	1	0
MAINTENANCE CONDUCTED IN LOCALLY CONSTRUCTED MAINTENANCE FACILITIES WITH HARD STAND	5	4	3	2	1	0

**Figure E-2. Completed environmental risk assessment matrix.**

**E-8. RISK RATING**

The task force commander rates the risk for each environmental area (each matrix) by adding the circled risk impact values (Figure E-3, page E-6). A blank copy of the overall risk assessment graph is provided for photocopying (Figure E-5, page E-15). The task force commander develops a risk assessment of the entire mission by adding the risk ratings for the individual matrixes on one form. The overall environmental risk falls into one of four categories: low, medium, high, or extremely high (Figure E-4, page E-6). Activities with an extremely high probability of environmental damage require Army forces (ARFOR)/division approval.

	MOVEMENT OF HEAVY VEHICLES/SYSTEMS	MOVEMENT OF PERSONNEL AND LIGHT VEHICLES/SYSTEMS	ASSEMBLY AREA ACTIVITIES	FIELD MAINTENANCE OF EQUIPMENT	MAINTENANCE CONDUCTED IN LOCALLY CONSTRUCTED MAINTENANCE FACILITIES WITH HARD STAND	RISK RATING
AIR POLLUTION	3	1	5	4	2	15
ARCHEOLOGICAL AND HISTORICAL SITES	3	3	0	1	0	7
HAZARDOUS MATERIALS AND HAZARDOUS WASTE	2	1	1	2	0	6
NOISE POLLUTION	1	0	1	0	0	2
THREATENED AND ENDANGERED SPECIES	1	1	0	0	0	2
WATER POLLUTION	5	2	3	2	0	12
WETLAND PROTECTION	5	2	1	2	0	10
OVERALL RATING	20	10	11	11	2	54

Figure E-3. Overall risk assessment.

CATEGORY	RANGE	ENVIRONMENTAL DAMAGE	DECISION MAKER
LOW	0 - 58	LITTLE OR NONE	UNIT COMMANDER
MEDIUM	59 - 117	MINOR	NEXT HIGHER COMMAND
HIGH	118 - 149	SIGNIFICANT	ARFOR/DIVISION
EXTREMELY HIGH	150 - 175	SEVERE	ARFOR

Figure E-4. Overall environmental risk.

**E-9. RISK REDUCTION**

The commander addresses each environmental area to reduce risks associated with the mission. While he considers all risk values above “0,” he obviously spends more time on risk values of “5” than he does on those valued at “1.” If the overall risk is low or medium, the commander will still review any areas rated high or extremely high. He should use his judgment in altering the mission to reduce the risk in this specific area. Many environmental

---

risk reduction measures are simply extensions of good management and leadership practices. Commanders can effectively manage environmental risks using the following six-steps.

a. **Step 1.** Identify hazards to the environment during mission analysis. Consider all activities that may pollute air, soil, and water. Also consider activities that may degrade natural or cultural resources.

b. **Step 2.** Assess the probability of environmental damage or violations with environmental risk assessment matrixes.

c. **Step 3.** Make decisions and develop measures to reduce high risks. Risk reduction measures can include:

- Rehearsals.
- Changing locations or times of operations.
- Increasing supervision.

d. **Step 4.** Brief chain of command, staff, and appropriate decision-makers on proposed plans and residual risk.

e. **Step 5.** Integrate environmental measures into plans, orders, SOPs, and rehearsals. Inform subordinates, down to individual soldier level, of risk reduction measures.

f. **Step 6.** Supervise and enforce environmental standards. Hold those in charge accountable for environmental risk reduction.

#### **E-10. RESIDUAL RISK**

Even with all practicable risk reduction measures in place, some risk will remain. This residual risk requires leader attention. Unit commanders inform the chain of command and appropriate decision-makers of residual risk and its implications for the mission. They also inform their subordinates and focus command and control efforts onto those portions of the mission.

#### **E-11. SUMMARY**

Unit commanders use environmental risk assessment to estimate the potential impact of a mission on the environment. The environmental risk assessment will allow leaders and their staffs to identify potential environmental problems before they occur. The process also allows the commander to identify and manage residual risk.

Value	Contributing Factors
5	Current or forecasted weather conditions will contribute to brush fires (dry and windy).
	AO is susceptible to brush fires.
	AO lacks vegetation/pavement and is susceptible to dust formulation.
	Vehicles and equipment are not reliable or well maintained.
	Soldiers are not proficient/experienced in the mission being conducted.
	Command and control is marginal.
	Sustained high OPTEMPO operations are planned.
4	Extensive use of external combustion equipment or explosives, incendiary devices, or flares is planned.
	Current or forecasted weather conditions could contribute to brush fires.
	AO is susceptible to brush fires.
	AO is susceptible to moderate dust formulation.
	Soldiers lack environmental awareness.
3	Some high OPTEMPO operations are planned.
	Some use of external combustion equipment explosives, incendiary devices, or flares is planned.
	Weather is favorable for the mission; winds are within safe operating limits.
	AO is safe from brush fires.
2	Soldiers are briefed on hazards of brush fires.
	Command and control is adequate.
	AO is safe from brush fires.
	AO is not susceptible to dust formulation.
	Soldiers are briefed on hazards of brush fires.
1	Soldiers are environmentally conscientious.
	Command and control is good.
	AO is not susceptible to brush fires.
	Fires are limited, controlled, and allowed only in authorized areas.
	CS (riot-control chemical agent) and obscurants are strictly controlled.
	Vehicles and equipment are well maintained and in good operating order.
	Soldiers are environmentally conscientious.
Soldiers are thoroughly familiar with fire restrictions.	
0	Command and control is excellent.
0	No risk/not applicable.

**Table E-2. Air pollution risk impact value.**

Value	Contributing Factors
5	Low-visibility, night, or sustained high OPTEMPO operations are planned.
	AO has many archeological, cultural, or historic resources.
	Archeological, cultural, and historic resources are neither identified nor marked off limits.
	Command and control is marginal.
	Soldiers are not familiar with the AO.
4	AO has some archeological, cultural, and historic resources.
	Archeological, cultural, and historic sites are marked off limits.
	Limited visibility operations are planned.
	Command and control is adequate.
	Soldiers are not familiar with the AO.
3	Archeological, cultural, and historic sites are identified and marked off limits.
	Soldiers have been briefed on off limits sites in AO.
	No low-visibility or night operations are planned.
	Command and control is adequate.
2	Archeological, cultural, and historic sites are identified and marked off limits.
	No low-visibility or night operations are planned.
	Command and control is good.
	Soldiers are familiar with the AO.
1	Archeological, cultural, and historic sites are identified and marked off limits.
	Soldiers avoid sites during training, operations, and logistical activities.
	Soldiers are proactive in recognizing, safeguarding, and reporting signs or evidence of possible archeological artifacts or sites.
	Command and control is effective.
	Soldiers are thoroughly familiar with the AO.
	Current or forecasted weather conditions are not an adverse factor.
0	No risk/not applicable.

**Table E-3. Archeological, cultural, and historic resources risk impact value.**

Value	Contributing Factors
5	Low-visibility, night, or sustained high OPTEMPO operations are planned.
	Operations are planned close to surface water sources.
	Current or forecasted weather conditions are harsh.
	Soldiers' experience with responding to HM or HW spills is limited or untested.
	Command and control is marginal.
	Soldiers lack environmental awareness.
4	Some high OPTEMPO operations are planned.
	Operations close to water sources are planned.
	Current or forecasted weather conditions are marginal.
	Some individuals are HM/HW qualified.
3	Soldiers are environmentally conscientious but not trained.
	Key HM/HW personnel are available during operations and maintenance activities.
	Adequate spill cleanup materials are available.
	Command and control is adequate.
	Current or forecasted weather conditions are not a factor.
2	Routine operations are planned (soldiers have adequate rest).
	Key HM/HW individuals will oversee high-risk HM/HW operations and maintenance activities.
	Soldiers are environmentally sensitive and HM/HW trained.
	Current or forecasted weather conditions are not a factor.
	Command and control is excellent.
1	Soldiers dealing with HM/HW are well trained and experienced.
	Task force HM/HW SOP is current (includes accurate HM/HW inventory and location) and fire department is provided with this inventory and location of HM/HW.
	Command and control is excellent.
	HM/HW is transported according to SOP.
	Tempo of operations and maintenance is routine.
	AO is well maintained and unit maintains good housekeeping practices.
0	No risk/not applicable.

**Table E-4. Hazardous materials and hazardous waste risk impact value.**



Value	Contributing Factors
5	Sustained high OPTEMPO operations are planned, with noise-generating equipment and activities (artillery, tracked vehicles, weapons firing, construction equipment, aircraft, power generation equipment).
	Operations are conducted in close proximity to the civilian populace.
	Command and control is marginal.
	Soldiers' proficiency in the operation being conducted is marginal.
	Soldiers lack environmental awareness.
	High OPTEMPO limited visibility operations are planned.
4	High OPTEMPO operations are planned with limited noise-generating activities (artillery, tracked vehicles, weapons firing, construction equipment, aircraft, power generation equipment).
	Command and control is adequate.
	Operations are conducted in close proximity to the civilian populace.
	Soldiers lack environmental awareness.
	Reduce levels of limited visibility operations are planned.
3	Level of noise-generating equipment is routine (wheeled vehicles, small generators, small arms fire).
	Civilian populace will be nominally affected.
	Command and control is adequate.
	Limited visibility operations may be conducted.
2	Level of noise generated is nominal.
	Command and control is good.
	Soldiers are environmentally conscientious.
	Limited visibility operations are not likely.
1	Minimum operations or maintenance activities are planned.
	Command and control is highly effective.
	Operations are conducted away from civilian populace.
	Limited visibility operations are not planned.
0	No risk/not applicable.

**Table E-5. Noise pollution risk impact value.**

Value	Contributing Factors
5	Threatened and endangered species' habitats are not identified.
	Threatened and endangered species' habitats are not marked off as a restricted area.
	Command and control is marginal.
	Sustained low-visibility or night operations are planned.
	Sustained high OPTEMPO operations are planned.
	Soldiers are not familiar with the AO.
4	Threatened and endangered species' habitats are marked off.
	Limited visibility operations are planned, and the soldiers are inexperienced.
	Command and control is adequate.
	Soldiers are not familiar with the AO.
3	Threatened and endangered species' habitats are marked off.
	Soldiers are briefed on threatened and endangered species.
	Limited visibility operations are planned with experienced soldiers.
	Command and control is adequate.
2	Threatened and endangered species' habitats are identified.
	Threatened and endangered species' habitats are marked off.
	Limited visibility operations are not planned.
	Command and control is good.
	Soldiers are familiar with the AO.
1	Threatened and endangered species' habitats are identified.
	Soldiers know and recognize threatened and endangered species.
	Threatened and endangered species' habitats are marked off as restricted/off-limits areas.
	Soldiers avoid threatened and endangered species' habitats during operations (when possible based upon the factors of METT-TC), and logistical activities.
	Command and control is effective.
	Soldiers are thoroughly familiar with the AO.
0	No risk/not applicable.

**Table E-6. Threatened and endangered species risk impact value.**

Value	Contributing Factors
5	Maneuver will cause significant terrain damage.
	Potential hazardous waste spills most likely will affect surface waters (wetlands, groundwater, streams, ditches, sewers, or drains).
	Limited visibility operations are planned.
	Soldiers' environmental proficiency is low.
	Command and control is marginal.
	Sustained high OPTEMPO operations are planned.
	Hazardous waste spill response is marginal or untested.
	Hazardous waste spill response material is not available.
4	Maneuver will cause some terrain damage.
	Potential spill hazard is minimal; will not affect surface waters, wetlands, groundwater, streams, ditches, sewers, or drains.
	High OPTEMPO operations are planned.
	Soldiers' environmental proficiency is somewhat low.
	Command and control is marginal.
3	Potential hazardous waste spill will pose no potential contamination of any water source.
	Routine operations are planned.
	Soldiers are environmentally sensitive.
	Command and control is adequate.
	Weather will not adversely affect operations.
2	Potential hazardous waste spill will pose no potential contamination of any water source.
	Routine operations are planned.
	Soldiers are environmentally sensitive.
	Command and control is good.
	Soldiers are trained in spill-response duties.
	Hazardous waste spill control material is readily available.
1	No potential for hazardous waste spill.
	Soldiers are very environmentally aware.
	Command and control is high.
	Soldiers maintain good housekeeping practices.
	Equipment is well maintained.
	Collection of maintenance wastes is managed properly.
0	No risk/not applicable.

**Table E-7. Water pollution risk impact value.**

Value	Contributing Factors
5	Sustained high OPTEMPO operations are planned.
	Command and control is marginal.
	Current or forecasted weather conditions will cause operations to adversely affect wetlands.
	Soldiers lack environmental awareness.
	Soldiers' proficiency in the operation being conducted is marginal.
	Field service or maintenance may have to be done near wetlands.
	Hazardous waste spill response is marginal.
	Hazardous waste spill response materials are not available.
4	Limited visibility operations are planned.
	Command and control is adequate.
	Soldiers are not familiar with the AO.
	Soldiers lack environmental awareness.
	Field service or maintenance may have to be done near wetlands.
3	Soldiers have been briefed on susceptibility of wetlands to damage.
	Limited visibility or night operations are not planned.
	Command and control is adequate.
2	Soldiers are environmentally conscientious.
	Limited visibility operations are not planned.
	Command and control is good.
	Soldiers are familiar with the AO.
1	Maintenance is conducted only in approved areas.
	Wetland areas and boundaries are identified.
	No refueling will be conducted in wetland areas.
	Streams/ditches will be crossed at designated crossings sites.
	Command and control is excellent.
	Soldiers are environmentally conscientious.
	Soldiers are familiar with AO.
	Collection of maintenance wastes is managed properly.
0	No risk/not applicable.

**Table E-8. Wetland protection risk impact value.**

	MOVEMENT OF HEAVY VEHICLES/SYSTEMS	MOVEMENT OF PERSONNEL AND LIGHT VEHICLES/SYSTEMS	ASSEMBLY AREA ACTIVITIES	FIELD MAINTENANCE OF EQUIPMENT	MAINTENANCE CONDUCTED IN LOCALLY CONSTRUCTED MAINTENANCE FACILITIES WITH HARD STAND	RISK RATING
AIR POLLUTION						
ARCHEOLOGICAL AND HISTORICAL SITES						
HAZARDOUS MATERIALS AND HAZARDOUS WASTE						
NOISE POLLUTION						
THREATENED AND ENDANGERED SPECIES						
WATER POLLUTION						
WETLAND PROTECTION						
OVERALL RATING						

Figure E-5. Overall risk assessment matrix.

---

## APPENDIX F

# SNIPER EMPLOYMENT

*Snipers play an important role in the battalion task force. They give the commander accurate, discriminatory, long-range small-arms fire. The best use of sniper fire is against key targets that other available weapon systems may be unable to destroy due to their range, size, or location; visibility; security and stealth requirements; avoidance of collateral damage; intensity of conflict; or rules of engagement. The techniques snipers use enable them to gather detailed, critical information about the enemy as a secondary role. The effectiveness of a sniper is measured by more than casualties or destroyed targets. Commanders know snipers also affect enemy activities, morale, and decisions. Knowing snipers are present hinders the enemy's movement, creates confusion and continuous personal fear, disrupts enemy operations and preparations, and compels the enemy to divert forces to deal with the snipers. (See FM 23-10.)*

### F-1. SNIPER TEAMS

Snipers avoid sustained battles. They operate in two-man teams, each consisting of one sniper and one observer, normally cross-trained. The observer carries an M16-series rifle; the sniper carries the sniper weapon system, and each member has a side arm. Team members help each other with range estimation, round adjustment, and security.

a. **Employment.** The commander or designated sniper employment officer controls sniper teams from a central location. Once deployed, snipers generally operate independently. They must understand the commander's intent, his concept of the operation, and the purpose for their assigned tasks. This allows the teams to exercise initiative within the framework of the commander's intent and to support the commander's concept and accomplishment of the unit's mission. Snipers are effective only in areas that offer good fields of fire and observation. They must have the freedom of action to choose their own positions once on the ground. The number of sniper teams participating in an operation depends on their availability, the expected duration of the mission, and the enemy's strength.

b. **Security Element.** Sniper teams should move with a security element (squad or platoon) whenever possible. This allows the teams to reach their areas of operation faster and safer than if they operated alone. The security element also protects the snipers during operations. When moving with a security element, snipers follow the following guidelines:

- (1) The leader of the security element leads the sniper team.
- (2) Snipers must appear to be an integral part of the security element. To do so, each sniper carries his weapon system in line with and close to his body to hide the weapon's outline and barrel length. Snipers also conceal from view all sniper-unique equipment (optics and ghillie suits).
- (3) The snipers' uniforms must be the same as that of security element members. Snipers and element members maintain proper intervals and positions in the element formation.

c. **Sniper Estimate.** History has proven that commanders need education on the proper use of a sniper. If commanders know the abilities and limitations of a sniper, the sniper can contribute significantly to the fight.

(1) **Mission.** The sniper's primary mission is to support combat operations by delivering precise rifle fire from concealed positions. The mission assigned to a sniper team for a particular operation consists of the task(s) the commander wants the sniper team to accomplish and the reason (purpose) for it. The commander must decide how he wants his sniper team to affect the battlefield. Then he must assign missions to achieve this effect.

(a) The commander should assign priorities to targets so snipers can avoid involvement in sustained engagements. Regardless of the target priorities, the sniper team must be free to change targets to support the commander's intent.

(b) The commander may describe the effect or result he expects and allow the sniper team to select key targets.

(c) The commander may assign specific types of targets to achieve an effect. For example, if he wants to disrupt the defensive preparations of the enemy, he may task snipers to kill bulldozer operators and other engineer equipment operators. He may task them to disable enemy vehicles carrying supplies, or he may task them to engage soldiers digging enemy defensive positions.

(d) The commander may assign specific targets. These can include enemy leaders, command and control operators, antitank guided missile gunners, armored-vehicle commanders, or weapons crews. In cases where large crowds pose a threat to US forces, snipers can single out selected individuals. In populated areas where US forces need to keep casualties to a minimum, snipers can be assigned to kill enemy snipers.

(2) **Enemy.** The commander must consider the characteristics, capabilities, strengths, weaknesses, and disposition of the enemy. Is the enemy force heavy or light, rested or tired, disciplined or not? Is it motorized infantry or towed artillery? Is it well supplied or short of supplies? Is it patrolling aggressively or lax in security? Is it positioned in assembly areas or dug in? The answers to questions like these help the commander determine the enemy's susceptibility and reaction to effective sniper operations. A well-rested, well-led, well-supplied, and aggressive enemy with armored protection poses a greater threat to snipers than one that is tired, poorly led, poorly supplied, lax, and unprotected. The commander needs to know if enemy snipers are present and effective since they can pose a significant danger to his operations and his snipers. The commander must consider the enemy's directed energy weapons capability since snipers are particularly vulnerable to these due to their use of optical devices.

(3) **Terrain.** The commander must evaluate and consider the terrain in and en route to the sniper's area of operations, the time and effort snipers will expend getting into position, and the effects of weather on the sniper and his visibility. Snipers prefer positions at least 300 meters from their target area. Operating at this distance allows them to avoid effective fire from enemy rifles while retaining much of the 800- to 1,000-meter effective range of the sniper rifle. Snipers need areas of operations with adequate observation, fields of fire, and good firing positions.

(4) **Troops.** The commander must decide how many sniper teams to use depending on their availability, the duration of the operation, expected opposition, and the number and difficulty of tasks and targets assigned. Commanders must consider the snipers' level of

training and physical conditioning and remember the effects of these human factors on sniper operations.

(5) **Time Available.** The commander must consider how much time the snipers will have to achieve the result he expects. He must allocate time for snipers to plan, coordinate, prepare, rehearse, move, and establish positions. The commander must understand how the snipers' risk increases when they lack adequate time to plan or to perform other tasks such as move to the area of operations. The amount of time a sniper team can remain in a position without loss of effectiveness due to eye fatigue, muscle strain, or cramps depends mostly on the type of position it occupies. Generally, snipers can remain in an expedient position for 6 hours before they must be relieved. They can remain in belly positions or semi-permanent hides for up to 48 hours before they must be relieved. Normal mission duration times average 24 hours. (FM 23-10 provides guidance on sniper position considerations, construction, and preparation and occupation times.) Movement factors for snipers moving with a security element are the same as for any infantry force. When snipers move alone in the area of operations, they move slowly; their movement can be measured in feet and inches. The sniper team is the best resource in determining how much time is required for their movement.

## F-2. OFFENSIVE EMPLOYMENT

Offensive operations carry the fight to the enemy to destroy his capability and will to fight. By killing enemy targets that threaten the success of the attack, the sniper can play a major role in offensive operations.

- a. **Offensive Missions.** During offensive operations, snipers--
  - Conduct countersniper operations.
  - Overwatch movement of friendly forces and suppress enemy targets that threaten the moving forces.
  - Place precision fire on enemy crew-served weapons teams and into exposed apertures of bunkers.
  - Place precision fire on enemy leaders, armored-vehicle drivers or commanders, FOs, and other designated personnel.
  - Place precision fire on small, isolated, bypassed forces.
  - Place precision fire on targets threatening a counterattack or fleeing.
  - Assist in screening a flank using supplemental fires.
- b. **Movement to Contact.** During a movement to contact, snipers move with the lead element, or they can be employed 24 to 48 hours before the unit's movement to--
  - Select positions.
  - Gather information about the enemy.
  - Deny enemy access to key terrain through controlled precision fires, preventing enemy surprise attacks.
- c. **Dismounted Assault.** During a mounted attack, fast movement limits the sniper's role. Snipers can provide effective support during a dismounted assault.
  - (1) Contact may force the mounted element to dismount and continue moving dismounted. Snipers placed with lead elements move to positions that allow them to overwatch the dismounted movement of the element and provide long-range small-arms fire. Sniper teams are most effective where BFVs and tanks are ineffective--that is, where



these vehicles cannot provide overwatching fires. In certain areas, the terrain may limit BFV and tank mobility. In other areas, the enemy situation may present an unacceptable risk to vehicles occupying hull defilade positions. Vehicle movement could compromise the stealth of the dismounted force. Multiple avenues must be overwatched.

(2) Snipers may also be placed with a mounted support element assigned to suppress, fix, or isolate the enemy on the objective. The sniper rifle's precision fire and lack of blast effect allow the sniper to provide closer supporting fires for assaulting soldiers than the mounted support element can provide. The difference in their weapons' effective ranges requires the snipers and the mounted support element to seek support by fire positions at different ranges when terrain allows. Long after BFVs and tanks are forced to shift or lift their supporting fires, snipers can selectively fire on close-in targets threatening the assault. These targets may be gunners of enemy crew-served weapons or enemy soldiers in fortified positions.

(3) If time permits, snipers may be deployed as soon as the element reaches the dismount point. Because the snipers' weapons have better optics and longer ranges than other types of small arms, they can provide additional long-range observation and precision fire on any enemy targets that may appear. To increase security, snipers may cover different sectors than the mounted elements.

(4) Snipers may move with the dismounted element toward the objective, occupy a close-in support by fire position where they can help suppress or destroy targets threatening the assault of the dismounted element, or move with the dismounted element onto the objective to provide close-in precision fire against enemy fortified positions, bunkers, and trench lines. Selection of the sniper support by fire position depends on METT-TC. The closer snipers are to the objective area, the greater the chance they will be discovered and lose their effectiveness.

(5) If mounted elements appear on the battlefield at the same time snipers arrive, the snipers' security and potential for surprise are degraded. To increase security and surprise, snipers may move covertly into position in an objective area well before the main attack and mounted forces arrive. Ideally, a sniper team going in early moves with infiltrating dismounted infantry. This is faster and more secure than moving alone. After the snipers are in position, dismounted infantrymen may remain nearby as additional security, but they are more likely to have other supporting tasks to perform. The proximity of dismounted infantry enhances security.

(6) After their fires are masked, snipers must reposition as soon as possible. The speed of mechanized assaults may prevent snipers from firing from more than one support position. The commander must carefully evaluate where snipers will be most useful. If he wants to use snipers in several different places, or if he wants them to contribute throughout the attack, he should provide transportation to enable them to move quickly, stealthily, and safely on the battlefield.

(7) Upon consolidation, snipers may displace forward to new positions that are not necessarily on the objective. From these positions, the snipers provide precision fire against bypassed enemy positions, enemy counterattack forces, or other enemy positions that could degrade the unit's ability to exploit the success of the attack.

d. **Raid.** During a raid, sniper teams can join with either the security element or the support element to--

- Cover avenues of approach and escape that lead in and out of the objective.

- Cover friendly routes of withdrawal to the rally point.
- Provide long-range fires on the objective.

### F-3. ACTIONS AGAINST FORTIFIED AREAS

Assaulting forces usually encounter some type of fortified positions prepared by the defending force. These can range from field-expedient, hasty positions produced with locally available materials to elaborate steel and concrete emplacements complete with turrets, underground tunnels, and crew quarters. Field-expedient positions are those most often encountered. More elaborate positions are likely when the enemy has had significant time to prepare his defense. He may have fortified weapons emplacements or bunkers, protected shelters, reinforced natural or constructed caves, entrenchments, and other obstacles.

a. **Enemy Defensive Positions.** The enemy tries to locate these positions so they are mutually supporting and arrayed in depth across the width of his sector. He tries to increase his advantages by covering and concealing positions and preparing fire plans and counterattack contingencies. Fortified areas should be bypassed and contained by a small force.

b. **Sniper Support.** The sniper's precision fire and observation capabilities are invaluable in the assault of a fortified area. Precision rifle fire can easily detect and destroy pinpoint targets that are invisible to the naked eye. The snipers' role during the assault of a fortified position is to deliver precision fire against observation posts, exposed personnel, and the embrasures, air vents, and doorways of key enemy positions. The commander plans the order in which snipers should destroy targets. Their destruction should systematically reduce the enemy's defense by destroying the ability of enemy positions to support each other. Once these positions are isolated, they can be reduced more easily. The commander must decide where he will try to penetrate the enemy's fortified positions and then employ his snipers against those locations. Snipers can provide continuous fire support for both assaulting units and other nearby units when operating from positions near the breach point on the flanks. Sniper fires add to the effectiveness of the entire unit; the commander can employ snipers in situations where other resources cannot be used for various reasons.

c. **Sniper Plan.** The sniper team bases its plan on information available. The enemy information it needs includes--

- Extent and exact locations of individual and underground fortifications.
- Fields of fire, directions of fire, locations and number of embrasures, and types of weapons systems in the fortifications.
- Locations of entrances, exits, and air vents in each emplacement.
- Locations and types of existing and reinforcing obstacles.
- Locations of weak spots in the enemy's defense.

### F-4. DEFENSIVE EMPLOYMENT

Snipers may effectively enhance or augment any unit's defensive fire plan. After analyzing the terrain, the sniper team should recommend options to the commander.

a. **Defensive Tasks.** The sniper team can perform the following tasks during defensive operations:

- Cover obstacles, minefields, roadblocks, and demolitions.
- Perform counterreconnaissance (kill enemy reconnaissance elements).
- Engage enemy OPs, armored-vehicle commanders exposed in turrets, and ATGM teams.
- Damage enemy vehicles' optics to degrade their movement.
- Suppress enemy crew-served weapons.
- Disrupt follow-on units with long-range small-arms fire.

b. **Primary Positions.** Snipers are generally positioned to observe or control one or more avenues of approach into the defensive position. Due to the types of weapons systems available, snipers may be used against secondary avenues of approach. Sniper employment can increase all-round security and allow the commander to concentrate his combat power against the most likely enemy avenue of approach. Snipers may support the battalion task force by providing extra optics for target acquisition and precise long-range fires to complement those of the M249, M240B, and M2 machine guns. This arrangement seeks to maximize the effectiveness of all the unit's weapons systems. Snipers in an economy-of-force role may cover dismounted enemy avenues of approach into TF positions.

c. **Alternate and Supplementary Positions.** Snipers establish alternate and supplementary positions for all-round security. Positions near the FEBA are vulnerable to concentrated attacks, enemy artillery, and obscurants. Multiple sniper teams, if used, can be positioned for surveillance and mutual fire support. If possible, they should establish positions in depth for continuous support during the fight. The sniper's rate of fire neither increases nor decreases as the enemy approaches. Sniper teams systematically and deliberately shoot specific targets, never sacrificing accuracy for speed.

d. **Key Terrain.** The commander can position snipers to overwatch key obstacles or terrain such as river-crossing sites, bridges, minefields, or anything that canalizes the enemy directly into engagement areas. Snipers are mainly used where weapons systems are less effective due to security requirements or terrain. Even though weapons systems with greater range and optics capability than the snipers' weapons are available to the commander, he may be unable to use them for any of several reasons. They might present too large a firing signature, be difficult to conceal well, create too much noise, or be needed more in other areas. Sniper team members provide the commander with better observation and greater killing ranges than do other soldiers.

e. **Force Security.** Snipers can be used as an integral part of the security effort. They can help acquire and destroy targets, augment the security element by occupying concealed positions for long periods, observe and direct indirect fires (to maintain their security), and engage targets. Selective long-range sniper fires are difficult for the enemy to detect. A few well-placed shots can disrupt enemy reconnaissance efforts, force him to deploy into combat formations, and deceive him as to the location of the main battle area. The sniper's stealth skills counter the skills of enemy reconnaissance elements. Snipers can be used where scout or rifle platoon mobility is unnecessary, freeing the scouts and riflemen to cover other sectors. Snipers can also be used to direct ground maneuver elements toward detected targets. This also helps maintain security so ground maneuver elements can be used against successive echelons of attacking enemy.

f. **Strongpoint Employment.** Snipers should be tasked to support any unit defending a strongpoint. The characteristics of the sniper team enable it to adapt to perform independent harassing and observation tasks in support of the force in the strongpoint, either from inside or outside the strongpoint.

g. **Reverse Slope Defense.** Snipers can provide effective long-range fires from positions forward of the topographical crest (or on the counterslope if the unit is occupying a reverse slope defense).

#### F-5. RETROGRADE EMPLOYMENT

The sniper team must know the concept, intent, scheme of maneuver, withdrawal times or conditions and priorities, routes, support positions, rally points, and locations of obstacles. Both engagement and disengagement criteria must be planned and coordinated to ensure snipers achieve the desired effect without compromising their positions.

a. **Force Enemy Deployment.** Snipers can help the delaying force cause the enemy to deploy prematurely during retrograde operations. They help by inflicting casualties with accurate, long-range small-arms fire. When the enemy receives effective small-arms fire from unknown positions, he is likely to assume he is near an enemy position (most likely one with ATGMs) and to begin maneuvering to a position of advantage against the perceived threat. Using a sniper team, the commander can achieve the same effect he could with another infantry unit. The snipers' stealth also gives them a better chance of infiltrating out of positions close to the enemy.

b. **Repositioning.** Delaying forces risk being bypassed or overtaken by attacking enemy forces. Commanders may provide transportation to move snipers to successive positions. Vehicles must remain in defilade positions to the rear of the sniper position, or they must occupy different positions away from the sniper's area of operations to avoid compromising the sniper's position. In either case, a linkup point, egress routes, and conditions for executing the linkup must be fully coordinated. Commanders may also provide communications assets to the sniper team to facilitate control and movement.

c. **Infiltration.** Snipers may be required to infiltrate back to friendly positions. Their infiltration plans must be fully coordinated to avoid fratricide when they try to reenter a friendly position. When planning successive positions, the commander must realize the sniper team may be unavailable for use if it is destroyed or is having difficulty disengaging from an enemy force. The commander must consider carefully how and where he wants snipers to contribute to the operation. Planning too many positions for the sniper team in a fast-paced retrograde may result in failure.

d. **Sniper Tasks.** Snipers may be assigned any of the following specific tasks:

- Delay the enemy by inflicting casualties.
- Observe avenues of approach.
- Cover key obstacles with precision fire.
- Direct artillery fire against large enemy formations.

#### F-6. URBAN OPERATIONS EMPLOYMENT

The value of the sniper to a unit conducting urban operations depends on several factors, including the type of operation, level of conflict, and rules of engagement. Where ROE allow destruction, the snipers may not be needed since other weapons systems available

to a mechanized force have greater destructive effect. But where ROE prohibit collateral damage, snipers may be the most valuable tool the commander has to employ.

a. **Urban Terrain.** Sniper effectiveness depends partly on the terrain. The characteristics of an urban area degrade control. To provide timely and effective support, the sniper must have a clear understanding of the scheme of maneuver and commander's intent.

(1) Observation and fields of fire are clearly defined by roadways, but rooftops, windows, and doorways limit surveillance. Each requires constant observation. The effects of smoke from military obscurants and burning buildings can degrade what otherwise appears to be an excellent vantage point. All-round defense becomes even more important because the enemy can fire from many directions and because enemy infiltration attempts must be countered.

(2) Cover and concealment are excellent for both the attacker and defender. The defender has a decisive advantage. The attacker normally exposes himself during movement through the area.

(3) Avenues of approach inside buildings are best. Movement there is less easily detected than movement through the streets. The sniper must be conscious of all avenues of approach and must be prepared to engage targets that appear on any of them.

b. **Positioning.** Snipers should be positioned in buildings of masonry construction that offer long-range fields of fire and all-round observation. The sniper has an advantage because he does not have to move with, or be positioned with, lead elements. He may occupy a higher position to the rear or flanks and some distance away from the element he is supporting. By operating far from the other elements, a sniper avoids decisive engagement but remains close enough to kill distant targets threatening the unit. Snipers should not be placed in obvious positions (such as church steeples and rooftops) since the enemy often observes these and targets them for destruction. Indirect fires can generally penetrate rooftops and cause casualties in top floors of buildings. Snipers should not be positioned where there is heavy traffic because these areas invite enemy observation as well.

c. **Multiple Positions.** Snipers should operate throughout the area of operations, moving with and supporting the company teams as necessary. Some teams may operate independent of other forces. They search for targets of opportunity, especially for enemy snipers. Since a single position may not afford adequate observation for the entire team without increasing the risk of detection by the enemy, the team may occupy multiple positions. Separate positions must maintain mutual support. Each team should also establish alternate and supplementary positions.

d. **Tasks.** The commander may assign the following tasks to snipers:

- Conduct countersniper operations.
- Kill targets of opportunity. (The sniper team assigns priorities to these targets based on an understanding of the commander's intent, for example, engaging enemy snipers, then leaders, vehicle commanders, radio men, sappers, and machine gun crews, in that order.)
- Deny enemy access to certain areas or avenues of approach (control key terrain).
- Provide fire support for barricades and other obstacles.
- Maintain surveillance of flank and rear avenues of approach (screen).

- Support local counterattacks with precision fire.

#### **F-7. STABILITY OPERATIONS AND SUPPORT OPERATIONS**

Snipers can be valuable to commanders in stability operations and support operations. Since ROE normally limit collateral damage and civilian casualties, snipers can selectively kill or wound key individuals who pose a threat to friendly forces. This selective engagement avoids unacceptable civilian casualties or collateral damage. Targets often hide in the midst of the civilian populace, which makes them virtually invulnerable to US forces that cannot destroy these targets without causing innocent casualties. An example would be a lone gunman in a crowd who fires at soldiers manning a roadblock. The soldiers must first identify the gunman (this is nearly impossible from their vantage point). Then, without hurting innocent bystanders, they must stop him from continuing to fire or from fleeing. This is an easier task for an overwatching sniper than for infantry on the ground. The sniper can look down on the crowd, use his optics to scan continuously, and employ precision fire to eliminate the identified enemy without harming bystanders. Though other unit optical systems may supplement the surveillance effort (Javelins and TOWs from the ground or from the upper floors of buildings), they do not engage the target because of the risk of innocent casualties. After identifying the target, Javelins and TOWs still need time to guide a precision weapon or maneuver a unit to address the target. The sniper rifle provides the commander the only system that can both identify and engage the target.

#### **F-8. RIVER CROSSINGS**

Sniper teams, by virtue of their observation and precision-fire capabilities, are uniquely adaptable to the initial stages of a river crossing. They are normally employed in general support of the TF both before and during the crossing.

a. **Positioning.** Snipers assume positions across the total width of the crossing area (if possible) before the crossing. Their main task is to observe. They report all sightings of enemy positions and activity immediately and provide a stealthy observation capability not otherwise available to the commander. Their stealth prevents the enemy from learning key facts like what type of unit is trying to cross. The snipers supplement normal reconnaissance assets.

b. **Crossing Support.** Snipers provide support during the crossing by continuing to observe and suppress enemy OPs and other key targets that heavier supporting elements might overlook. The snipers' ability to continue to provide close-in suppressive fire makes continuous fire support possible up to the moment elements reach the far side and begin their movement to establish the bridgehead line. Snipers should be positioned as early as possible, preferably as part of the reconnaissance force. Their movement across the river must also be planned in advance. How they will get across and where their subsequent positions will be must be coordinated. Generally, they displace once friendly elements reach the far side.

c. **Inserted Force Support.** Snipers expand the capability of the inserted force to engage threatening targets at long ranges. Once on the far side, snipers may screen the flank or rear of the crossing force, infiltrate to destroy key targets (such as a demolition guard or fortified emplacement), or man OPs well to the front of the crossing force. This

placement increases both early warning time and the crossing force's ability to disrupt enemy counterattack forces.

### **F-9. PATROLLING**

The effective employment of sniper teams with any size or type of patrol is limited only by the terrain and the patrol leader's ingenuity. Snipers must know and be able to apply all aspects of patrolling.

a. **Reconnaissance Patrols.** Snipers normally remain with the security element during reconnaissance patrols. If terrain permits, snipers can provide long-range support to enable the reconnaissance element to patrol farther from the security element. To prevent compromise of the reconnaissance element's position, snipers fire only in self-defense or when ordered by the patrol leader. Normally, the only appropriate time to fire at a target of opportunity is when extraction or departure from the position is imminent and firing will not endanger the success of the patrol.

b. **Raid Patrols.** Sniper employment on a raid depends on the time of day and the size of the patrol. When the patrol needs maximum firepower and its size must be limited, snipers may be excluded. If, on the other hand, the patrol needs long-range precision fire and its size permits, sniper teams may be attached to the security element. If appropriate, the sniper team may be attached to the support element to help provide long-range supporting fires. When attached to the security element, the sniper team helps observe, helps prevent enemy escape from the objective area, and helps cover the withdrawal of the assault force to the rally point. When the element withdraws from the rally point, the sniper team may stay behind to delay and harass enemy counteraction or pursuit.

c. **Ambush Patrols.** During ambushes, snipers are positioned in areas that afford observation and fields of fire on terrain features the enemy might use for cover after the ambush has begun. The snipers' long-range capability allows them to be positioned away from the main body. Sniper fires are coordinated into the fire plan. Once the signal to initiate fires is given, snipers add their fires to the rest of the patrols. Snipers shoot leaders, radio operators, and crew-served weapons teams. If the enemy is mounted, every effort is made to kill drivers of the lead and trail vehicles to block the road, prevent escape, and create confusion. Snipers may remain in position to cover the withdrawal of the patrol.

## APPENDIX G

# FIRES INTEGRATION

*Synchronization between the fires and maneuver battlefield operating systems is critical to mission success. The planning process must integrate these two BOS into a single, coordinated effort. After planning guidance is issued to the fire support officer, the entire staff must work to ensure that the technical and procedural aspects of fire support are understood and crafted in a way that maximizes the effects of fire support while complementing the maneuver plan. The challenge to the combined arms commander is to achieve synchronization. While success in any battle, engagement, or operation is never guaranteed, its achievement is much more likely for the commander who can synchronize military actions.*

### G-1. COMMANDER'S GUIDANCE FOR FIRE SUPPORT

The commander's early and continuous involvement in the fire support plan is essential to ensure that fires are effectively synchronized with the maneuver plan. At a minimum, the commander must articulate what he wants from the indirect assets in the form of a task and purpose for fires at each critical event on the battlefield. The commander's guidance for fire support becomes the basis for the battalion task force concept of fires and the fires paragraph (Table G-1, page G-2).

a. It is important for the FSO and the battalion task force commander to have a common understanding of what fires must do to support the operation before the FSO begins to develop the plan of how to do it. The battalion task force staff (with the commander's approval) may further define the initial EFSTs as the MDMP progresses, but the more clearly the commander defines them initially the more focused and effective fire support planning will be.

b. A task for fire support describes a targeting effect against a specific enemy formation's function or ability. The purpose describes how this effect contributes to accomplishing the mission within the intent. The commander's initial planning guidance for fire support will become the basis for the concept of fires and the fires paragraph. Synchronization in the plan will depend largely on the commander's ability to issue planning guidance to BOS representatives that cause them to develop integrated COAs.

c. As EFSTs are determined during the MDMP using a top-down planning, bottom-up refinement process, fires are integrated into the scheme of maneuver. If the staff has thoroughly war-gamed possible enemy and friendly courses of action, the resultant fire support plan is focused. That is, it provides the effects desired by the commander when and where he wants them to help accomplish the mission. During execution, the only thing that should be allowed to desynchronize the plan is enemy actions not previously considered. Since this will almost always occur, the commander must have a system in place to immediately make D3A decisions, disseminate them and execute them violently. Fighting the enemy (not the plan) in accordance with the commander's guidance provides focus.

d. In terms of a *brigade versus battalion fight*, there is only one fire plan. The top-down plan developed and refined during the MDMP and preparation phase should incorporate EFSTs supporting brigade and battalion (and company) schemes of



maneuver. As (if) fires shift from deeper to closer targets, execution responsibility tends to shift from brigade to battalion. In executing the fire plan, brigade *does not hand fires off to subordinate headquarters; it hands off the responsibility for executing certain EFSTs to subordinate headquarters*. In this manner, brigade fires remain synchronized with brigade maneuver while still supporting subordinate maneuver units. The expected conflict between simultaneously attacking targets the battalion wants attacked by fires and attacking targets the brigade wants attacked by fires must be planned for and war-gamed in the MDMP.

<b>EFSTs.</b> What fire support is to accomplish, providing task and purpose at a minimum.
<b>Focus for Fires.</b> Focus by phase of the battle and linked to specific events.
<b>Targets.</b> The type of target to be engaged and the desired effect on each.
<b>Force Protection Priorities.</b> The priorities for protecting friendly forces and for counterfire.
<b>Restrictions and Priorities for Special Munitions.</b> (Include use of smoke, SCATMINEs, Copperheads, or illumination)
<b>Observer Plan.</b> Employment of COLTs, STYKERS, etc.
<b>Radar Guidance.</b> Establishment of radar zones, security of radar systems
<b>Fire Support Coordination Measures.</b>
<b>ROE Guidance.</b> Protected target list.
<b>Engagement Criteria.</b> Guidance of size and type of units to be engaged at selected points in the operation.

**Table G-1. Commander’s guidance for fire support**

**G-2. PLANNING AND INTEGRATION OF FIRE SUPPORT EFFECTS**

The planning and integration of fire support effects occurs during steps three and four (COA development and COA analysis) of the MDMP.

a. As the battalion task force staff begins COA development, the FSO (based on initial fire support guidance from the commander) conceptualizes how to integrate fires into the developing concept of operations. The FSO uses the approved EFSTs and battalion task force commander's guidance for fire support to develop where and how he recommends the allocation of fire support assets to each COA. The output for this step is a draft fire support plan for each COA.

(1) The FSO and staff conduct the following actions during COA development.

(a) They determine where to find and attack EFST formations. The battle staff determines where the enemy formations identified by the commander can be found and attacked. The staff graphically portrays these locations using TAIs or EAs.

(b) They identify HPTs in EFST formations (target value analysis). Certain sub-elements, capabilities, or equipment sets within the EFST formations may be more vulnerable to attack with fires and or may provide the best effects if attacked. This process results in identifying or refining the HPTs.

(c) The battalion task force FSO uses products from brigade-level target value analysis to assist him in the targeting process (decide phase) during COA development. These products include:

- HPTL - a prioritized list of HPTs.
- AGM - addresses which targets will be attacked, how, when, and desired effects.
- Target selecting system (TSS) - addresses accuracy and time criteria that must be met before targets can be attacked

**NOTE:** At battalion task force level the FSO will rarely develop his own HPTL, AGM, or TSS. Examples of targeting products developed at brigade level can be found in FM6-20-40. For further explanation of these products refer to FM6-20-10.

(d) The TF staff quantifies effects for EFSTs and quantifies success. It focuses on what must be accomplished to achieve the EFST. If desired effects cannot be achieved with the assets allocated, the staff must rework the method or request additional assets.

(e) The TF staff plans methods for EFSTs (allocate assets to acquire/allocate assets to attack). This step involves allocating or assigning assets to detect and track HPTs. The maneuver S2, S3, and battalion task force FSO work together as they build this part of the R&S plan. They then determine who can execute the task based on the battalion task force scheme of maneuver, acquisition asset capabilities, and the priorities of the collection plan. The FSO must consider asset general movement and positioning requirements (for example, FOs, FISTs, or COLTS) to enable execution of fires with refinements made during war-gaming.

(f) The TF staff integrates triggers with maneuver COA. The synchronization of maneuver and fire support is essential for success. The FSO must understand the relative timing of maneuver and fires and establish triggers that reflect this. For example, "When the lead team crosses Phase Line Dog, the obscuration smoke will be fired at grid NK 124757." Triggers are further refined during the COA analysis war gaming process and during the combined arms rehearsals.

(g) The staff uses battle calculus to test feasibility. As the FSO and battle staff develop COAs, they must apply doctrinal or measured rates, planning factors, speeds, and other data to ensure the plan is feasible.

(h) The FSO assists the S2 in ISR plan development. He coordinates with the S2 and S3 to ensure there are adequate, redundant collection assets to find, track, and attack the HPTs in the fire support plan.

(i) The commander and staff must integrate the task force mortar platoon into the fire plan:

- The mortar platoon leader must be actively involved in developing the fire support plan.
- The TF commander should integrate the mortar platoon at each phase of the operation.
- The mortar platoon requires a copy of the FS execution matrix to assist in technical data processing.

(2) The result of the above listed actions is the output of a draft fire support plan for each COA, branch plan, or sequel. EFSTs should be clearly identified. The draft battalion task force fire support plan will include the following:

- Draft fires paragraph/concept of fires.
- Draft FSEM that graphically communicates the details of the fires paragraph. It ties executors to targets relative to time and or events of the scheme of maneuver.
- Draft target list worksheet and overlay that provides detailed description of targets, tentative target locations based on IPB, and in modified form can provide the task and purpose of each target and link each target to the EFST it supports. The overlay provides a graphic depiction of the target locations.
- Develop ISR plan. The FSO assists the S2 and S3 in its development.

b. During COA analysis, the staff refines the necessary details of the concept of the operation. During the war game process, targets and triggers are refined. As the battle staff conducts an action-reaction-counteraction drill to cause and respond to enemy acts, the war game provides the FSO with the opportunity to finalize targeting decisions (refine targets, establish primary and alternate executors, and their triggers), visualize and synchronize the fire support plan with maneuver, test and refine the fire support plan, and modify the plan based on the above. Based on the issues identified by the war game, the FSO and staff can modify the draft fire support plan and products.

(1) During COA analysis, the following actions occur:

- Finalize HPTL and other targeting decisions.
- War-game fire support plan against enemy COA.
- Modify and or refine fires products.

(2) Based on the above actions, the output of the COA analysis is a refined fires products to include the following:

- Fire support annex.
- FSEM.
- Target list.
- Target list overlay.

c. Upon completion of the operations order, the commander must ensure that the fires plan, which may be well synchronized in the OPORD, is similarly well synchronized during the execution of the mission. He ensures fires synchronization after the issuance of the OPORD by supervising the following activities:

- Active participation during the maneuver and fires rehearsals.
- Back briefs from subordinate leaders on their understanding and execution of the fires plan.
- Ground reconnaissance with his subordinate leaders to ensure that the observation plan is properly positioned to obtain desired results.

### **G-3. OBSERVATION AND TARGET EXECUTION PLANNING AND PREPARATION**

Company team commanders will often find themselves as the observer (and executor) of battalion fires. Understanding the concept of echelonment of fires is critical for the indirect fire plan to be effectively synchronized with the maneuver plan. The purpose of echeloning fires is to maintain constant fires on an objective while using the optimum delivery system up to the point of its risk estimate distance (RED) in combat operations or minimum safe distance (MSD) in training. Echeloning fires provides protection for friendly forces as they move to and assault an objective, allowing them to get in close with minimal casualties. It prevents the enemy from observing and engaging the assault by forcing the enemy to take cover, allowing the friendly force to continue the advance unimpeded.

a. The concept behind echeloning fires is to begin attacking targets on or around the objective using the weapons system with the largest RED-combat (or MSD-training). As the maneuver unit closes the distance (i.e., crosses the RED line) enroute to the objective, the fires lift (or shift). This triggers the engagement of the targets by the delivery system with the next largest RED-combat (or MSD-training). The length of time to engage the targets is based on the rate of the friendly force's movement between the RED-combat (or MSD-training) trigger lines. The process continues until the system with the least RED-combat (or MSD-training) lifts and the maneuver unit is close enough to make its final assault and clear the objective.

b. The RED-combat (or MSD-training) takes into account the bursting radius of particular munitions and the characteristics of the delivery system and associates this combination with a percentage for the probability of incapacitation of soldiers at a given range. The RED-combat (or MSD-training) is defined as the minimum distance friendly troops can approach the effects of friendly fires without suffering appreciable casualties of 0.1% or higher probability of incapacitation.

#### **WARNING**

**Risk estimate distances are for combat use and do not represent the maximum fragmentation envelopes of the weapons listed. Risk estimate distances are not minimum safe distances for peacetime training use.**

c. The casualty criterion is the 5-minute assault criterion for a prone soldier in winter clothing and helmet. Physical incapacitation means that a soldier is physically unable to function in an assault within a 5-minute period after an attack. A probability of

incapacitation value of less than 0.1 percent can be interpreted as being less than or equal to one chance in one thousand (Table G-2).

System	Description	Risk Estimate Distances (Meters)					
		10% PI			0.1% PI		
		1/3 range	2/3 range	Max range	1/3 range	2/3 range	Max range
M224	60 mm mortar	60	65	65	100	150	175
M252	81 mm mortar	75	80	80	165	185	230
M120/M121	120 mm mortar	100	100	100	150	300	400
M102/M119	105 mm howitzer	85	85	90	175	200	275
M109/M198	155 mm howitzer	100	100	125	200	280	450
	155 mm DPICM	150	180	200	280	300	475

**Table G-2. Risk estimate distances for mortars and cannon artillery.**

d. Using echelonment of fires within the specified RED-combat (or MSD-training) for a delivery system requires the unit to assume some risks. The maneuver commander determines by delivery system how close he will allow fires to fall in proximity to his forces. The maneuver commander makes the decision for this risk level, but he relies heavily on the FSO's expertise.

e. The following are the planning steps when echeloning fires (Figure G-1).

(1) **STEP 1.** The FSO must determine what FS assets (lethal and nonlethal) are available for the preparation. The FSO should consider the following:

- Does the NGF gun-target line support use of naval surface fire support (NSFS) in the preparation?
- Submit the replanned CAS request within the correct ATO cycle.
- Identify and adjust for ammunition constraints and limitations (controlled supply rate may restrict or limit the use of certain types of ammunition).
- Dud rates and self-destruct times of improved conventional munitions. These types of munitions may be best suited to the flanks and beyond the objective and not on the objective.

(2) **STEP 2.** Verify risk estimate distances and commander's attack criteria. Risk estimate distance allows the commander to estimate the risk in terms of percent of friendly casualties that may result from the employment of lethal fires with close proximity of friendly forces. Risk estimate distances are based on the amount of risk the maneuver commander is willing to accept. The risk is usually expressed as the probability of incapacitation, which is the probability that a soldier will suffer an incapacitating injury.

(3) **STEP 3.** Plan targets on the objective, to the flanks of the objective, and beyond the objective. Timely and accurate intelligence is critical to this step. Weapons and ammunition should be matched to the appropriate target.

(4) **STEP 4.** Develop a communications plan to support the fires. The preparation may involve many FS assets over a considerable distance; reliable and redundant means of digital and voice communications are essential. Consider establishing both a ground and air retransmission capability.

(5) **STEP 5.** Determine the rate of movement of the force. This will vary depending on the type maneuver force and terrain; a fully mechanized force will travel much further and faster than a light infantry force. A combination of heavy and light forces will also be different. The S2's IPB should assist in determining a reasonable rate of movement. Caution is advised, as any movement rate determined can change. Close monitoring of subordinate units' movements is necessary and FSOs must develop a plan to alter the schedule of fires based on the movement rate.

(6) **STEP 6.** Develop the schedule of fires. Normally, fires begin before H-hour and may extend beyond it. Firing may start at a prescribed time or it may be held on call until needed. The preparation may be phased as follows:

- Phase 1 – Attack of FS means and observation capabilities, including FA HQ and CPs. Consider adding air defense targets in this phase as well.
- Phase 2 – Attack of main CPs, communications facilities, assembly areas, and reserves.
- Phase 3 – Attack of defensive areas in the forward positions and targets that pose an immediate threat to attacking units or forces.

The attacking force is most vulnerable to counter attack during reorganization. Include defensive fires in the plan to cover this phase.

(7) **STEP 7.** Brief the plan. The FSO should backbrief the commander and S3 prior to completing the scheduling worksheets. During the FS portion of the operations order brief, be thorough; it is critical that the subordinate commanders understand the preparation sequence and their responsibilities. A sketch may be.

(8) **STEP 8.** Complete the scheduling worksheets and ensure all elements receive a copy.

(9) **STEP 9.** Rehearse and refine the plan. The rehearsal should cover all EFSTs and not just the echeloning of fires.

1. Determine what assets, to include ammunition, are required and what assets are currently available or allocated.
2. Verify risk estimate distances and attack criteria with the commander.
3. Plan targets.
4. Develop a communications plan.
5. Determine what the rate of movement will be.
6. Develop the schedule of fires and decide how the preparation schedule will be initiated.
7. Brief the plan/confirm the method with the commander.
8. Complete the scheduling work sheets.
9. Rehearse and refine the plan.

**Figure G-1. Echeloning a preparation.**

#### **G-4. EXECUTION CONSIDERATIONS**

When the lead elements of the battalion task force approach the designated phase line enroute to the objective the FSO begins the preparation. Lead element observers and or company team FSOs track movement rates and confirm them for the battalion task force FSO. The battalion task force FSO may need to adjust the plan during execution based on unforeseen changes to anticipated movement rates. (Refer to Figure G-2, Figure G-3, and Figure G-4, page G-10.)

- a. As the unit continues its movement toward the objective, the first delivery system engages its targets. It maintains fires on the targets until the unit crosses the next phase line that corresponds to the RED-combat (or MSD-training) of the weapon .
- b. To maintain constant fires on the targets the unit must start the next asset before the previous asset lifts. This ensures no break in fires, enabling the friendly forces' approach to continue unimpeded. However, if the unit rate of march changes, the fire support system must remain flexible to the changes.
- c. The FSO lifts and engages with each asset at the prescribed triggers, initiating the fires from the system with the largest RED to the smallest. Once the maneuver element reaches the final phase line to lift all fires on the objective, the FSO shifts to targets beyond the objective.

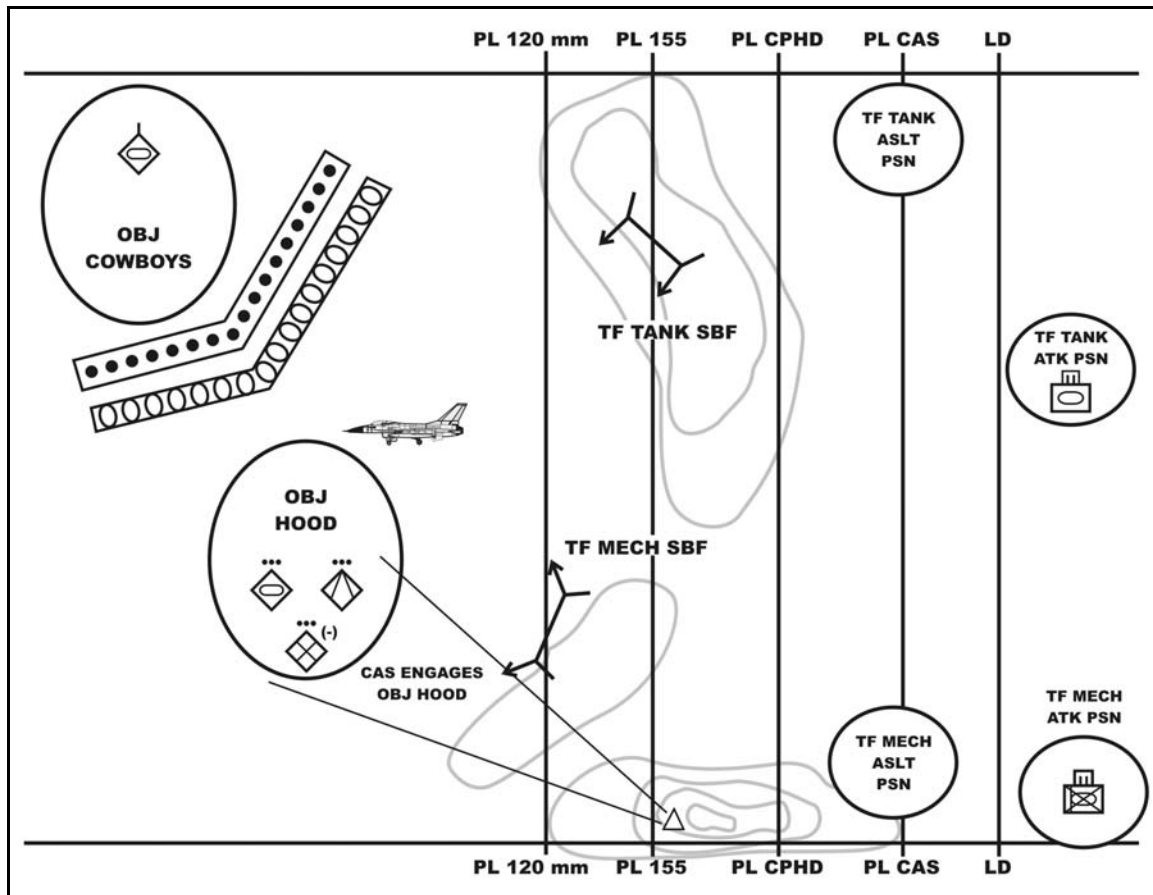


Figure G-2. Execution considerations – close air support.

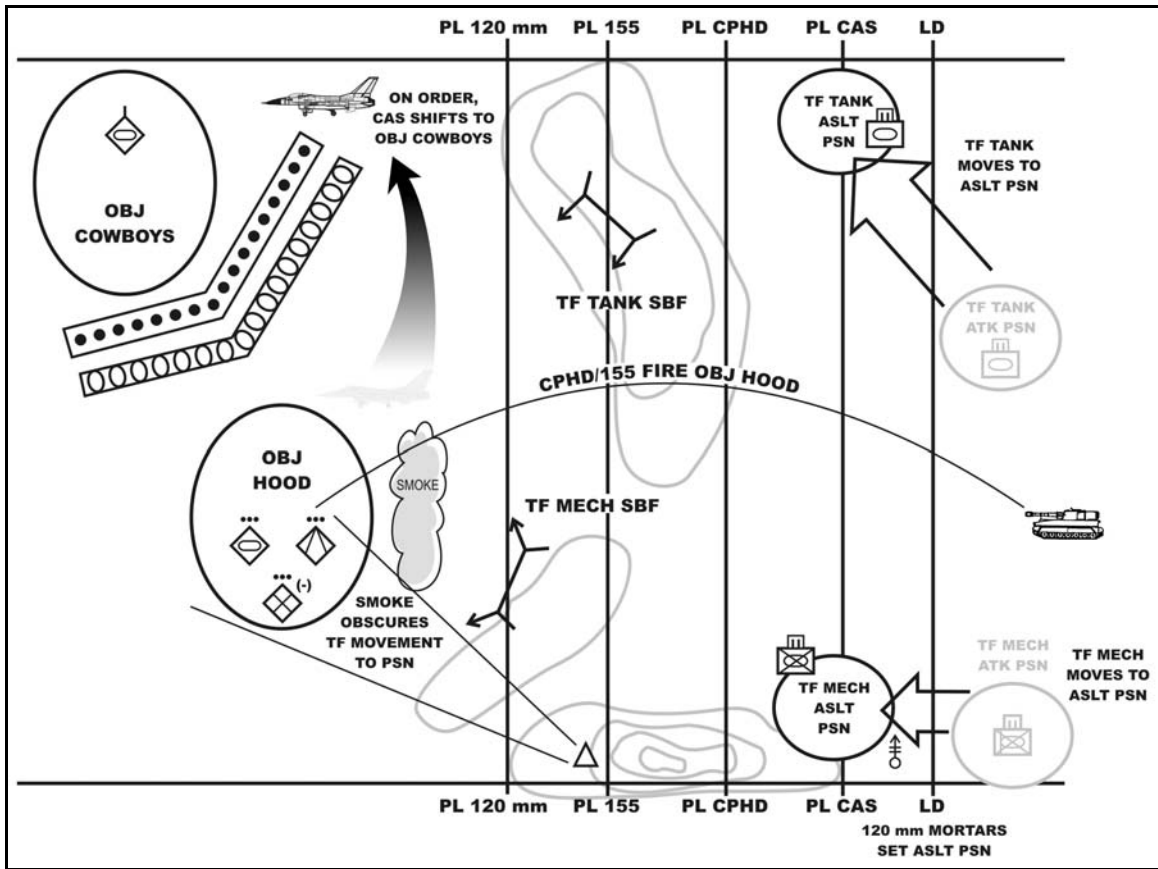


Figure G-3. Execution considerations – shaping fires.



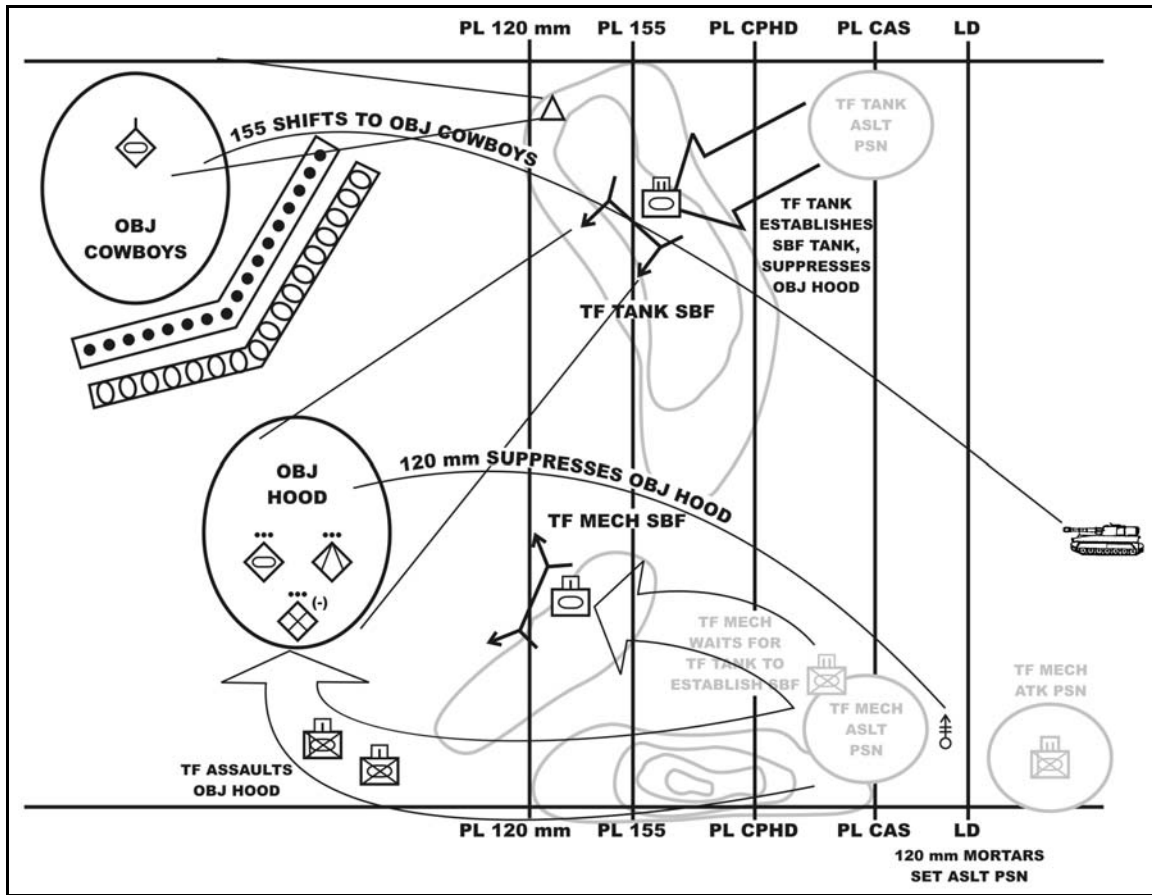


Figure G-4. Execution considerations – actions on objective.

---

## APPENDIX H DEPLOYMENT

*The US Army, as a key member of the joint team, is required to be ready for global force projection actions with an appropriate mix of combat, CS, and CSS forces to fight and win our nation's battles. To meet the force projection requirements, the tank and mechanized infantry battalion task force must be ready to meet all deployment timelines and activities. Peacetime preparation, speed, in-depth coordination, rehearsals, and knowledge are necessary if the task force is to meet its deployment timelines.*

### Section I. FORCE PROJECTION

Force projection is the demonstrated ability to alert, mobilize, deploy rapidly, and operate effectively anywhere in the world. Force projection is the military component of power projection.

#### H-1. FORCE PROJECTION PROCESS

Force projection encompasses a series of processes that occur in a continuous, overlapping, and iterative sequence (see Figure H-1, page H-2).

a. **Mobilization.** Mobilization is the process by which the Armed Forces or parts of them are brought to a state of readiness for war or other national emergency. This includes activating all or part of the reserve components (RCs) as well as assembling and organizing personnel, supplies, and materiel.

b. **Deployment.** Deployment is the movement or relocation of forces and materiel from their home stations to the desired AOs.

c. **Employment.** Employment is the application of force or forces to attain specified military objectives. Employment concepts determine the scope of mobilization, deployment, sustainment, and redeployment activities.

d. **Sustainment.** Sustainment is the provision of personnel, logistics, and other support required to maintain and prolong operations or combat until successful accomplishment of the mission or of the national objective.

e. **Redeployment.** Redeployment is the transfer of a unit, an individual, or supplies deployed in one area to another area for the purpose of employment or return to home station.

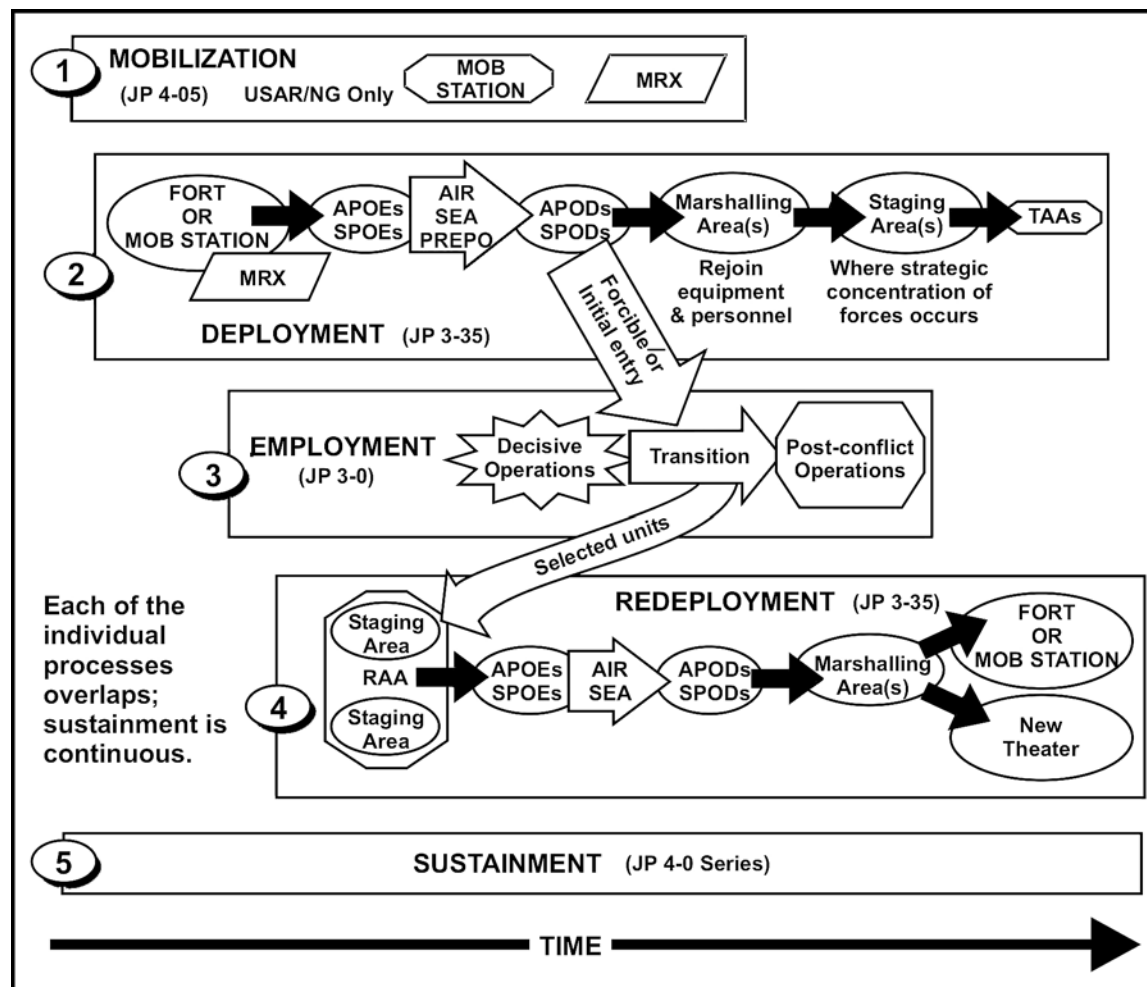


Figure H-1. Force projection process.

## H-2. DEPLOYMENT AND EMPLOYMENT INTERRELATIONSHIP

Each process impacts the other. This is especially true of the deployment and employment interrelationship. Deployment and employment are inextricably linked; neither can be planned successfully without a firm grasp of the other. Consequently, the operational speed and tempo reflect the ability of the deployment pipeline to deliver combat power where and when the joint force commander wants it. Any disruption in the deployment timeline accordingly impacts on employment.

### Section II. DEPLOYMENT PHASES

Deployment is the relocation of forces and materiel to a specific operational area to conduct operations outlined in a plan or order. It encompasses all activities from origin or home station through destination, specifically including intracontinental US, intertheater, and intratheater movement legs. Each brigade, division, and corps will have differing methods to prepare a unit for deployment. Brigade staff officers must be thoroughly knowledgeable in the deployment steps outlined by the higher headquarters and installation. Unit deployments consist of three distinct and interrelated phases:

- Predeployment activities taken at home stations.
- Movement to port of debarkation (POD) (fort-to-port and port-to-port activities).
- Reception, staging, onward movement and integration (port to destination).

### H-3. PREDEPLOYMENT ACTIVITIES

The Army's challenge in becoming more strategically responsive begins at TF home station by decreasing the amount of time required to execute all predeployment activities. Predeployment activities are those actions taken to prepare the TF for deployment. These tasks are essentially constant and ongoing activities performed at the home station before and during the predeployment phase to prepare forces for deployment. These tasks are conducted before and after the issuing of a warning or alert notification. Predeployment activities are not limited to the deploying unit but include supporting units and the installation staff.

a. **Planning and Training Validation.** The TF conducts peacetime training on those METL tasks they expect to execute in wartime. In addition to its METL tasks, the unit focuses on the individual and collective tasks that support its wartime mission. The TF, with assistance from the higher headquarters, prepares mobilization and deployment plans and deployment training. Typical planning and training includes--

- Mobilization training and preparation.
- Unit movement officer and NCO activities.
- Unit load team training and vehicle marking.
- Hazardous materials (HAZMAT) cargo certification.
- Airload planning for all brigade vehicles and equipment.
- Soldier readiness preparations (SRP) and personnel asset inventory (PAI).
- Deployment exercises and or rehearsals are conducted.
- Family support group (FSG) meetings.
- Higher headquarters and brigade war plans review and intelligence updates.
- Classes III, V, and VIII deployment stocks reviewed and or updated.
- Stocks of Class IV blocking, bracing, and tie down materials are verified.
- Requests for batteries and other PLL/ ASL shortages are submitted.
- Individual and crew-served weapons qualifications are conducted.
- Access rosters for personnel requiring access to secure facilities are submitted.

b. **Alert.** The alert phase begins with the receipt of a WARNO for deployment. Based upon the time-phased force and deployment data list (TPFDDL), the TF may have from hours to several days from notification to movement. Specific activities during this phase include--

- Receipt and verification of deployment orders.
- Recall of the unit soldiers.
- Initiation of x-hour sequence of events.
- Completion of SRP activities.
- Upload of vehicles with equipment.
- Configure pallets and containerized loads.
- Issue COMSEC materials.
- Issue movement orders and instructions.

- Prepare manifest lists for movement.
- Transfer all nondeploying equipment to rear detachment.
- Update critical equipment shortage lists.
- Pick up ammunition from the ammunition supply point (ASP).
- Conduct OPSEC sweeps of the brigade area.
- Conduct analysis of division order.
- Upload contingency stocks for Class I and chemical detection equipment (CDE).
- Conduct personal property inventories of deploying soldiers.
- Prepare transportation coordinator's automated information formovement system (TC-AIMS II) and military shipping labels for all vehicles and personnel.

c. **Deployment.** During this phase, the TF takes the necessary steps to clear the installation, finalize deployment plans, conduct any final coordination with the higher headquarters or installation and deploys an advance party to the aerial port of debarkation (APOD). Other activities include the following:

- Leaders conduct a tactical exercise without troops (TEWT) to all deployment nodes.
- TF S4 conducts all coordination with brigade, division, or post transportation offices for movement times and routes from brigade marshalling areas to the APOD/seaport of debarkation (SPOD).
- Rear detachment confirms barracks security, personally owned vehicle (POV) storage areas, and arms rooms.
- Movement from the TF areas to the deployment nodes.

d. **Planning and Training Validation.** During this phase, the TF must complete all training and preparations in anticipation for deployment. The unit must take all possible steps and actions to reduce the number of excess predeployment activities. The time spent to complete or redo any of the predeployment training and preparations increases the time before the unit is ready for employment or adds to the time before the unit can be employed in theater.

#### **H-4. MOVEMENT TO PORT OF EMBARKATION**

Early deploying TFs will move directly from their home stations with equipment and vehicles via air mission command airlift into the theater of operations for immediate employment. These units are primarily light, airborne, or air assault forces comprising the rapid deployment force. Heavy units will send their equipment from the home station to a port of embarkation (POE) for onward movement or fall in on pre-positioned stocks in theater. Once the unit completes all training, the personnel will move into the theater via airlift and fall in on their equipment at the POD.

a. Most of the TF vehicles and equipment will be rail-loaded from the post directly into the theater or to a seaport for movement to the theater. TF commanders--

- Ensure verification of route and movement times with the division transportation officer (DTO).
- Conduct a route reconnaissance to POE.
- Properly mark all brigade vehicles.

- Check for security of onboard equipment and equipment listed in the table of organization and equipment (TOE).
- Pre-brief all drivers and vehicle commanders.
- Provide strip maps to all vehicles.
- Ensure verification of vehicle load plans.
- Provide joint inspection of vehicles and equipment to air/sea port authorities.
- Ensure center-of-gravity markings are on all vehicles and trailers.
- Ensure that one hundred percent of all tie-down equipment is available and serviceable.
- Verify that HAZMAT items are identified and labeled.
- Ensure that vehicles are reduced to lowest possible dimensions.
- Ensure that vehicles and fuel cans are filled to 3/4 full.
- Ensure that vehicle antennas are removed and radios are waterproofed.
- Verify that all vehicle drivers are licensed for their vehicle.
- Ensure generators are purged.

b. The TF planners must ensure that all coordination and activities are completed prior to the arrival of the unit's vehicles at the rail loading site. This is usually completed during the predeployment phase. However, unit planners should expect problems, delays, and confusion at the POE. The TF is probably not the only unit deploying or attempting to coordinate movement activities. Planners should know the locations of staging/marshalling areas, joint inspection criteria, and understand the entire movement plan. TF commanders and or planners should take positive actions to facilitate the movement of the unit by being present at critical times, always having communications with the POE authorities and facilities to take care of the soldiers.

c. This phase begins with the departure of TF equipment from the POD (either by sea, rail, or air) and ends with the arrival at the POE. At this point, all TF personnel are either conducting final training with borrowed equipment, en route to the POE via air/sea lift, or waiting in-theater for the equipment to arrive. The TF commander keeps in close contact with the movement officer and tracks the status of TF equipment movement. Upon arrival at the POE, the TF commander immediately checks with the movement office to verify the expected time of equipment arrival. Have load teams and drivers standing by ready to assist with the download of equipment upon arrival. If traveling with the TF equipment, the commander or movement officer coordinates with the flight crew, train engineer, or ship's cargo loading officer to make periodic checks of the unit's equipment. Generally, if the equipment is prepared correctly prior to departure, it will travel without any mishaps. The commander's main concern should be for the welfare and morale of the accompanying soldiers. He keeps the soldiers informed of where the TF is going and what is going to happen when it arrives at the POE.

#### **H-5. RECEPTION, STAGING, ONWARD MOVEMENT, AND INTEGRATION**

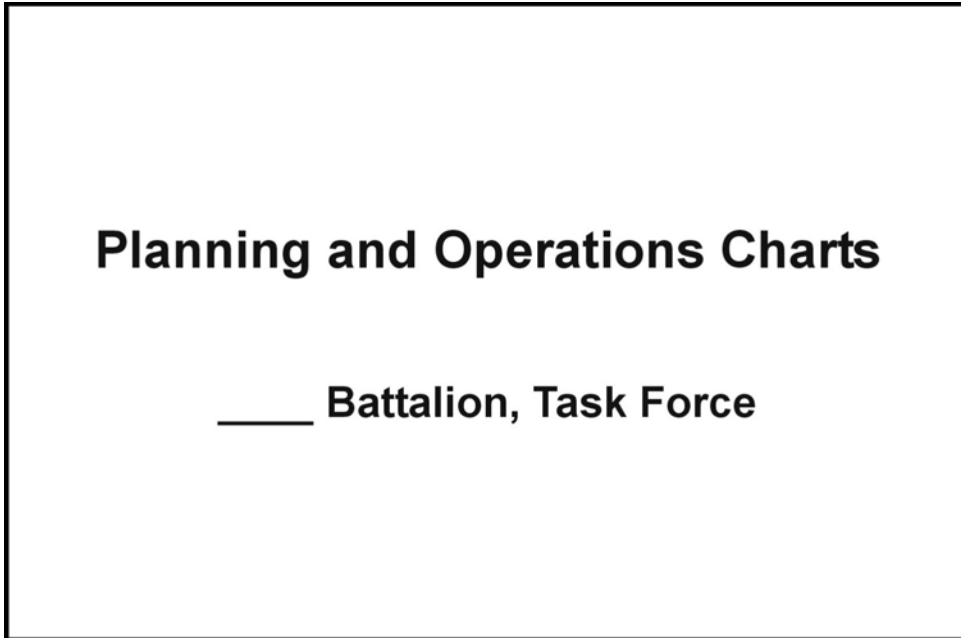
Upon arrival in the theater, the TF receives its equipment and makes preparations for integration into the theater commander's plans. During this phase, the unit can expect CS and CSS elements to assist in processing the TF through the POD. This process is known as RSOI:

- *Reception* is the process of unloading personnel and material from strategic seaport, marshaling the deploying units, transporting them to staging areas, if required, and providing life support to deploying personnel.
- *Staging* is the process of assembling, holding, and organizing all arriving personnel and equipment into units and forces for movement. During staging, the commander incrementally builds combat power and prepares units for onward movements while providing life support until the unit becomes self-sufficient.
- *Onward movement* is the movement of units and accompanying material from reception facilities and staging areas to tactical assembly areas. This includes moving non-unit personnel to gaining commands and moving sustainment material from reception facilities to distribution sites.
- *Integration* is the synchronized transfer of authority over units and forces for employment in-theater.
  - a. As the initial step in the introduction of combat power, reception can determine the success or failure of an entire operation. TF commander actions during the reception phase must be thoroughly planned and carefully executed. Reception from strategic lift assets will be near the aerial port of embarkation (APOE) and should provide all of the support required until the TF equipment and vehicles arrive.
  - b. Prior to departing the APOE/seaport of embarkation (SPOE) for the assembly area, ensure that all TF equipment and personnel are ready for war. This is a commander's only chance to get things straight prior to departure. RSOI considerations include--
    - Verification and accountability of all sensitive items and keys to all vehicles and equipment.
    - Top-off of all vehicle fluids.
    - Issue and upload all ammunition.
    - Receive all classes of supply and water.
    - Complete all vehicle PMCS and order needed parts.
    - Conduct communication checks on all radios.
    - Receive updates on the condition of the local security and threat.
    - Verify routes, checkpoints, and assembly areas.
    - Conduct necessary repairs to equipment.
    - Receive specialized theater-specific equipment issue.
    - Conduct digital network exercise to ensure that the digital architecture is functioning properly.

APPENDIX I  
**PLANNING AND OPERATIONS CHARTS**

*The battalion task force often operates for extended periods of time in continuous operations. Continuous operations are combat operations continuing at the same high intensity level for extended periods. Figures I-1 through I-37 provide examples of planning and operations charts that can enhance the capability of leaders to sense the battlefield during extended combat or tactical operations and reduce degradation in performance over time. See also FM 3-90.3, Appendix H, Planning and Operations Status Charts.*

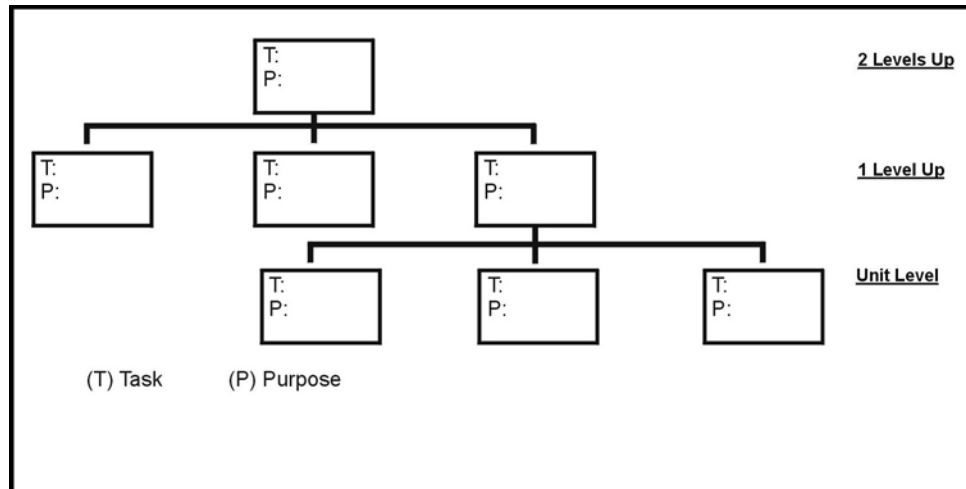




**Figure I-1. Example planning and operations charts cover sheet.**

<b>MISSION ANALYSIS BRIEFING AGENDA</b>		
1.	AO/AI/BATTLESPACE ORIENTATION	TIO
2.	REVIEW CDR'S INITIAL GUIDANCE	S3 AIR
3.	HIGHER HQ'S MISSION & INTENT 2 LEVELS UP	S3 AIR
4.	INITIAL IPB PRODUCTS	
	TERRAIN & WEATHER ANALYSIS	TIO
	ENEMY COMP/DISP/STRENGTH/CAPABILITIES	S2
	ENEMY COAs (SI TEMP)	S2
5.	RECOMMENDED CCIR	S3 AIR
6.	INITIAL COLLECTION PLAN	AS3/TIO
7.	SPECIFIED/IMPLIED/ESSENTIAL TASKS	AS3
8.	CONSTRAINTS ON THE OPERATION	AS3
9.	CURRENT TASK ORG/COMBAT POWER (TO PLT LEVEL)	AS3
10.	CBT MULT ANALYSIS	AS NEC
	FSO           Assets/Issues	
	ENG           Assets/Issues	
	ADO           Assets/Issues	
	S-1/S-4       Assets/Issues	
11.	RECOMMENDED TIMELINES	S3 AIR
12.	RECOMMENDED RESTATED MISSION	S3 AIR
13.	ISSUE CDR'S GUIDANCE	CDR

**Figure I-2. Example mission analysis briefing agenda.**



**Figure I-3. Example higher HQ concept sketch.**

<b>HIGHER HEADQUARTERS' ORDER</b>	
1. DIVISION	MISSION:  INTENT:
2. BRIGADE	MISSION:  INTENT:

**Figure I-4. Example higher HQ order.**

<b>COMMANDER'S INITIAL GUIDANCE</b>	
<b>PLANNING GUIDANCE</b>	
<b>RECON GUIDANCE</b>	
<b>CCIR</b>	
<b>INITIAL MOVEMENT</b>	
<b>SECURITY REQUIREMENTS</b>	
<b>TIMELINE GUIDANCE</b>	
<b>INITIAL COA GUIDANCE</b>	
<b>INITIAL CBT MULT/BOS GUIDANCE</b>	
<b>OTHER</b>	

**Figure I-5. Example commander's initial guidance.**

<b>TERRAIN ANALYSIS WORKSHEET</b>	
<b>EFFECTS/CONCLUSIONS</b>	
<b>Maneuver</b>	
Foot	
Wheel	
Mech	
<b>Intel</b>	
<b>Engineer</b>	
<b>Fire Support</b>	
<b>ADA</b>	
<b>CAS</b>	
<b>CSS</b>	
<b>Recon/Surv</b>	
<b>C2</b>	

**LEGEND:**    **G** POSITIVE    **A** MARGINAL    **R** NEGATIVE

**Figure I-6. Example terrain analysis worksheet—effects and conclusions.**

TERRAIN ANALYSIS WORKSHEET										
Maneuver	OBSTACLES		A o As		KEY TERRAIN		OBS & FOF		COV & CONC	
	Friendly	Enemy	Friendly	Enemy	Friendly	Enemy	Friendly	Enemy	Friendly	Enemy
Foot										
Wheel										
Tracked										
<b>ABN/ASLT</b>										
<b>Fire Support</b>										
<b>Engineer</b>										
<b>IEW</b>										
<b>ADA</b>										
<b>CAS (AVN)</b>										
<b>NBC</b>										
<b>C2</b>										

LEGEND: (G) POSITIVE (A) MARGINAL (R) NEGATIVE

Figure I-7. Example terrain analysis worksheet—factors.

WEATHER ANALYSIS WORKSHEET		
Maneuver	FRIENDLY / ENEMY	EFFECTS (VIS, MOB, SURV)
Foot		
Wheel		
Mech		
<b>Aviation</b>		
<b>Engineer</b>		
<b>Fire Support</b>		
<b>ADA</b>		
<b>CAS</b>		
<b>Chemical</b>		
<b>Recon/Surv</b>		
<b>C2</b>		

LEGEND: (G) POSITIVE (A) MARGINAL (R) NEGATIVE

Figure I-8. Example weather analysis worksheet.

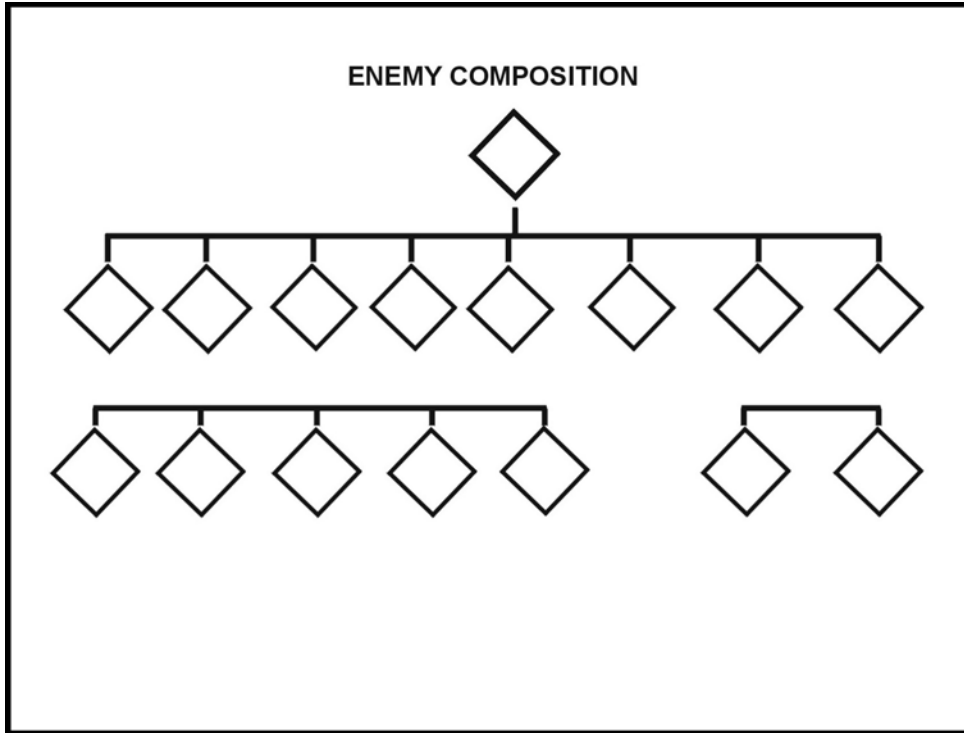


Figure I-9. Example enemy composition.

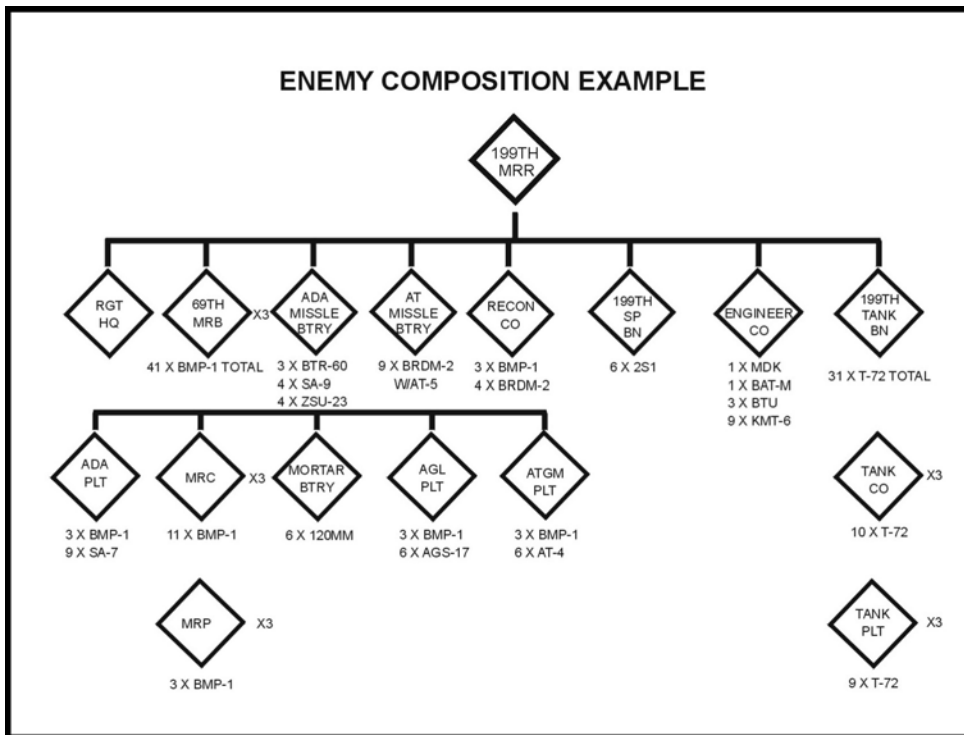


Figure I-10. Example enemy composition.

ENEMY DISPOSITION/STRENGTH					
		<u>AGAINST BN/BDE</u>		<u>AGAINST BDE/DIV</u>	
		Committed	Reinforcing	Committed	Reinforcing
Unit ID & Strength	Type				
	MRB				
AR Co					
MRC					
AR Bn					
AT Bn					
FS					

Figure I-11. Example enemy disposition/strength chart.

ENEMY CAPABILITIES	
ASSET	CAPABILITIES
ISR	
MANEUVER	
FIRE SUPPORT	
MOB / SURV	
ADA	
NBC	
AVIATION	
EW	

Figure I-12. Example enemy capabilities chart.

<b>ENEMY COA #1 SKETCH</b>	<b>CONCEPT STATEMENT</b>	
	T.O.	
<b>MISSION:</b>	<b>ASSUMPTIONS</b>	
<b>HPTL:</b>	<b>STRENGTH</b>	<b>WEAKNESS</b>

Figure I-13. Example enemy COA #1 chart.

<b>ENEMY COA #2 SKETCH</b>	<b>CONCEPT STATEMENT</b>	
	T.O.	
<b>MISSION:</b>	<b>ASSUMPTIONS</b>	
<b>HPTL:</b>	<b>STRENGTH</b>	<b>WEAKNESS</b>

Figure I-14. Example enemy COA #2 chart.





ISR PLAN MATRIX						
UNIT & STATUS	NAI	GRID	NET	NLT	INDICATOR	OBS ACTION

Figure I-17. Example R&S matrix.

INITIAL ISR ORDER		
MISSION	INITIAL NAIs	FIRE SUPPORT
	LD/LC TIME	
RECON AO	PASS OF LINES INSTR	
RECON OBJs	COMMO PLAN	
RT's TO AO	LOG SUPPORT	
MEDEVAC		COLL ASSETS AVAIL

Figure I-18. Example initial R&S plan.

TASKS & CONSTRAINTS	
SPECIFIED TASKS	IMPLIED TASKS

Figure I-19. Example tasks and constraints chart.

TASKS & CONSTRAINTS	
ESSENTIAL TASKS	CONSTRAINTS

Figure I-20. Example tasks and constraints chart.

CURRENT TASK ORGANIZATION/COMBAT POWER												
TASK ORGANIZATION		TOW	BFV	TANK	SQD	JAVELIN	MRTR	SCT VEH	DS ARTY			
		A O	A O	A O	A O	A O	A O	A O	A O	A O		
PLT CO	1	2	3	HQ	PERS	REMARKS						

Figure I-21. Example current task organization/combat power.

CSS STATUS					
UNIT	ASSESSMENT	MANNING ISSUES	ARMING ISSUES	FUELING ISSUES	FIXING ISSUES
	___ %				
	___ %				
	___ %				
	___ %				
	___ %				
	___ %				

Figure I-22. Example CSS status chart.

CLASSES OF SUPPLY			
CLASS SUPPLY	CURRENT STATUS (DOS)	PROJECTED STATUS (DOS)	CRITICAL SHORTAGES/CONCERNS
I			
II			
III			
III(P)			
IV			
V			
VI			
VII			
VIII			
IX			
OTHER			

Figure I-23. Example classes of supply chart.

CLASS III/V USAGE AND PROJECTION					
	ON HAND	PROJECTED USE	RESUPPLY BY GAS	CSR	BY UNIT IMPACT
CL III BULK					
CL III PACKAGE					
CL V (Critical or high expenditure)					
5.56 mm					
7.62 mm					
TANK					
BRADLEY					
STINGER					
M109					
MORTAR					

Figure I-24. Example class III/V usage and projection chart.

END ITEM STATUS			
SYSTEM	CURRENT ON-HAND STATUS	PROJECTED ON-HAND STATUS	REMARKS
M1			
M2			
BSFV			
M109			
M106			
AH64			

NOTE: Projected on-hand status refers to combat systems available after task organization. Use the blank boxes available for new systems such as attack helicopters or M960s.

Figure I-25. Example end item status chart.

COMMANDER'S GUIDANCE	
COA GUIDANCE	MOB/C-MOB/SURVIVABILITY GUIDANCE
CCIR	SECURITY MEASURES
RECON GUIDANCE	CS/CSS PRIORITIES
DECEPTION GUIDANCE	OTHER:
FIRE SUPPORT GUIDANCE	TIME PLAN
	TYPE REHEARSALS

Figure I-26. Example commander's guidance chart.

<b>COA BRIEF AGENDA</b>	
RESTATED MISSION	S3 AIR
HIGHER CDR'S INTENT	S3 AIR
REVIEW CDR'S GUIDANCE	S3 AIR
UPDATED TIMELINE	AS3
UPDATED IPB	S2
REVIEW RCPA	S3 AIR
COA #1	S3 AIR
SIGNIFICANT FACTORS	
HPTLs	
COA #2	AS3
SIGNIFICANT FACTORS	
HPTLs	
UPDATED FACTS & ASSUMPTIONS	S3 AIR
COA ANALYSIS GUIDANCE	CDR/XO

**Figure I-27. Example COA brief agenda chart.**

<b>RESTATED MISSION STATEMENT</b>

**Figure I-28. Example restated mission statement.**

RCPA MATRIX				
CRITERIA	FRIENDLY FORCES	ENEMY FORCES	SIGNIFICANT FACTORS	TTPs
	STRENGTHS			
	WEAKNESSES			
	STRENGTHS			
	WEAKNESSES			
	STRENGTHS			
	WEAKNESSES			
	STRENGTHS			
	WEAKNESSES			
	STRENGTHS			
	WEAKNESSES			

Figure I-29. Example RCPA matrix.

COA #1 SKETCH	CONCEPT STATEMENT	
	T.O.	
MISSION:	ASSUMPTIONS	
HPTL:	STRENGTH	WEAKNESSES

Figure I-30. Example COA Sketch #1.

<b>COA #2 SKETCH</b>	<b>CONCEPT STATEMENT</b>	
	T.O.	
<b>MISSION:</b>	<b>ASSUMPTIONS</b>	
<b>HPTL:</b>	<b>STRENGTH</b>	<b>WEAKNESSES</b>

**Figure I-31. Example COA #2 sketch.**

<b>COA COMPARISON</b>				
<b>CRITERIA</b>	<b>WEIGHT</b>	<b>COA #1</b>	<b>COA #2</b>	<b>COA #3</b>
<b>TOTAL</b>				
<b>ADVANTAGES</b>				
<b>DISADVANTAGES</b>				
<b>RISK</b>				

**Figure I-32. Example COA comparison chart.**



<b>DECISION BRIEF AGENDA</b>	
INTRODUCTION	S3 AIR
HIGHER CDR'S INTENT	S3 AIR
UNIT MISSION	S3 AIR
UPDATED IPB	S2
STATUS OF FORCES	S1/S4
REVIEW COAs	S3 AIR/AS3
TASK ORGANIZATION	
COA STATEMENT AND SKETCH	
ADVANTAGES & DISADVANTAGES	
RISK	
DECISION MATRIX	S3 AIR
RECOMMENDED COA	S3 AIR
UPDATED TIMELINES	S3 AIR
CDR'S DETAILED COA ANALYSIS GUIDANCE	CDR

**Figure I-33. Example decision brief agenda.**

<b>LIGHT AND WEATHER</b>					
DATE					
SR/SS					
MR/MS					
HI/LO					
% ILLUM					
WINDS					
PRECIP					
REMARKS					
BMNT					
EENT					

**Figure I-34. Example light and weather chart.**

ENEMY SITUATION	
COMP/DISP	CAPABILITIES BY BOS
	INTEL
	MAN
	F.S.
	MOBILITY/C-MOB/SURVIVABILITY
	ADA
	CSS
C2	
STRENGTHS	WEAKNESSES

Figure I-35. Example enemy situation chart.

COMMANDER'S INTENT
<b><u>PURPOSE:</u></b>
<b><u>KEY TASKS:</u></b>
<b><u>END STATE:</u></b>

Figure I-36. Example commander's intent.

		TIMELINE																							
		DATE:	TIMELINE																						OF
		0100	0200	0300	0400	0500	0600	0700	0800	0900	1000	1100	1200	1300	1400	1500	1600	1700	1800	1900	2000	2100	2200	2300	2400
ENEMY																									
OPERATIONAL																									
PLANNING																									

Figure I-37. Example timeline.

---

**APPENDIX J**  
**AIR ASSAULT OPERATIONS**

*When the battalion task force executes an air assault operation, mechanized infantry company teams form the primary air assault force. Usually, one or two company teams form the basic air assault force, but a mechanized pure force may use all three company teams. Higher headquarters provides the additional assets required to execute an air assault mission. In most cases, the operation concludes with a linkup operation between infantry and mounted forces.*

**Section I. MECHANIZED AIR ASSAULT OPERATIONS**

Situations favoring an air assault operation for a mechanized force include those in which the enemy has a vulnerable area suitable for air assault, surprise can be achieved, and enemy air defenses are weak and vulnerable or can be effectively suppressed.

**J-1. AIR ASSAULT MISSION ANALYSIS AND CONSIDERATIONS**

Although mechanized infantry units are not frequently employed in air assault operations, such operations, conducted on a limited scale, may be the decisive form of combat. Typical air assault operations conducted by mechanized forces are river-crossing operations, seizure of key terrain, rear area combat operations, and raids. Mechanized infantry units of the heavy division can exploit the mobility and speed of organic or supporting helicopters to secure a deep objective in the offense, reinforce a threatened sector in the defense, or place combat power at a decisive point on the battlefield. For this reason, they must be proficient in conducting air assault operations.

a. When mechanized infantry is used in the air assault role, the disposition of the unit's vehicles is also a point of consideration. The combat vehicles of the battalion task force (-) can be--

- Attached for movement to an assaulting ground element (linkup force).
  - Left in an assembly area until the assaulting element returns.
  - Repositioned to provide supporting fires for adjacent units or the air assaulting force.
- b. Other considerations include the following:
- Ground mobility is limited once the unit is inserted unless vehicles are provided.
  - Communication range is limited to that of portable radios.
  - Range of the scout platoon is limited unless its vehicles are lifted into the objective area.
  - Antiarmor capability is reduced.
  - Combat support and combat service support are austere.
  - Air lines of communication must be planned for sustainment.
  - Disposition of the 120-mm mortars depends on the ability to displace the tubes and ammunition. The M1100 trailer indigenous to light and special operation forces may meet this requirement.

c. All other mission analysis factors are in FM 90-4 and are not unique to mechanized forces deployed in this role.

## **J-2. AIR ASSAULT BATTALION TASK FORCE ORGANIZATION**

As with all air assault operations, the battalion task force is organized to meet METT-TC and operational considerations.

## **J-3. ACTIONS OF THE BATTALION TASK FORCE (-)**

The OPORD should reflect detailed planning for actions of the entire force, not only the air assault element but also the battalion task force (-) or battalion task force (-) stay-behinds. This planning should emphasize command and control relationships, operational restrictions due to limited numbers of dismounted infantry, and linkup procedures. Should the battalion task force (-) or its combat equipment be tasked to perform linkup operations with its deployed infantry, operation and maneuver control of its combat vehicles must be planned carefully. Battalion task force (-) combat vehicles can be used for feints and deception operations prior to linkup with their deployed forces.

## **Section II. PLANNING CONSIDERATIONS**

The battalion task force commander and staff should review the following planning considerations during the military decision-making process leading to an air assault operation.

## **J-4. INTELLIGENCE**

The primary enemy tactics against air assault operations can be broken down into four major areas:

- Air defense fires (including small arms).
- Fixed- and rotary-wing aircraft.
- Electronic warfare.
- Enemy reaction to LZ operations.

The commander and staff must understand the capabilities and limitations of enemy aircraft in the AO and take all measures to minimize the risk of encounter. They must analyze enemy capabilities to interdict friendly LZs with ground forces, artillery, and CAS during the planning phase of the operation.

## **J-5. MANEUVER**

Habitual relationships and the integration of infantry and Army aviation allow infantrymen and supporting fires to strike rapidly over extended distances. To provide surprise and shock effect, the required combat power should be delivered to the objective area as early as possible, consistent with aircraft and pickup zone capabilities. Attack helicopters, if available, are used primarily in an antiarmor role and integrated into the tactical plan of the ground force commander. However, during air assault operations, they additionally support the lift and assault force by direct and indirect fires. Air assault forces operate relatively free of the terrain influences that restrict surface operations. Air assault forces are best employed to locate and defeat enemy forces and installations or to seize terrain objectives preventing enemy withdrawal, reinforcement, and supply and the shifting and reinforcement of enemy reserves.

**J-6. FIRE SUPPORT**

Fire support planning must provide for suppressive fires along flight routes and in the vicinity of LZs. Priority of fires must be the suppression of enemy air defenses. Displacement of FS assets and resupply depends on helicopters as prime movers unless prime movers are lifted into the area. Suppression of suspected ADA sites along flight routes is vital to the success of an air assault operation. Naval gunfire (NGF) support and USAF CAS may be available to augment available artillery.

**J-7. ENGINEER SUPPORT**

Engineers in an air assault operation assist mobility by constructing or expanding helicopter LZs and FARPs and rehabilitating existing forward aviation maintenance sites. Engineers assist in breaching obstacles and fight as infantry when required.

**J-8. AIR DEFENSE ARTILLERY**

ADA assets provide protection against low-flying aircraft and attack helicopters. Early warning of enemy air is broadcast over the division early warning net. BSFVs or Linebackers are used primarily to support maneuver units. Avengers, if available, are used to protect C2 and static assets.

**J-9. COMBAT SERVICE SUPPORT**

Support of organic aviation units is extensive. FARPs are necessary to maintain the fast pace of air assault operations. The battalion task force's organic assets push supplies, material, fuel, and ammunition forward by helicopter to support the air assault operation.

**J-10. COMMAND AND CONTROL**

The key to successful air assault operations lies in precise, centralized planning and aggressive, decentralized execution. The availability of aviation assets is normally the major factor in determining task organization. Task organization must be determined and announced early in the planning process. Units must maintain tactical integrity throughout an air assault operation. Squads are normally loaded intact on the same helicopter to ensure unit integrity upon landing. (Paragraph J-12a below addresses the loading of personnel in helicopters.)

**Section III. AIR ASSAULT PLANNING STAGES**

The successful execution of an air assault depends on a careful mission analysis by the commander and staff and a detailed, precise reverse planning sequence. The five basic plans that comprise an air assault operation are the ground tactical plan, the landing plan, the air movement plan, the loading plan, and the staging plan (Figure J-1, page J-4). In mechanized infantry battalion and task force operations, the ground tactical plan also includes a linkup plan. Air assaults are planned in reverse order, beginning with the ground tactical plan and working in a reverse sequence to the staging plan (Figure J-2, page J-4, and Figure J-3, page J-5).

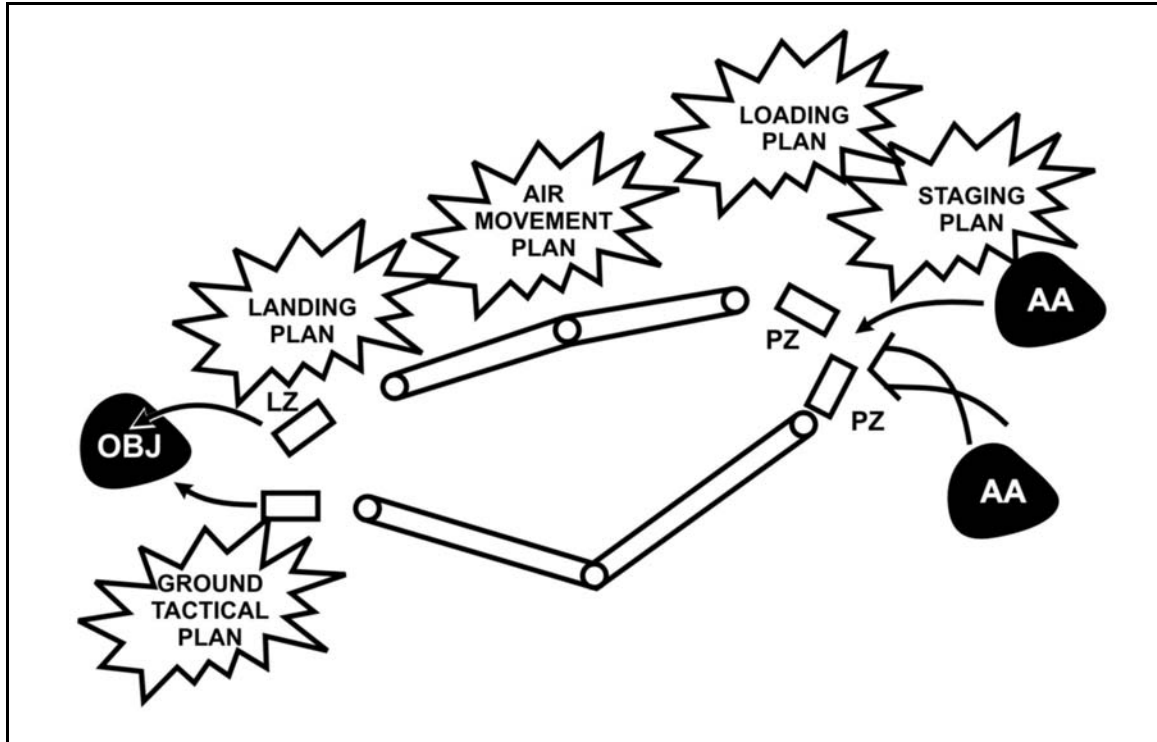


Figure J-1. Air assault planning process.

EVENT	STATUS	TIME
AMB CONDUCTED		
PZ SECURED		
DART TEAM STANDING BY		
SEAD EXECUTED		
ISR OF HLZ SUFFICIENT		
A2C2 COORDINATION COMPLETE		

Figure J-2. Air assault criteria.

Go	No Go	BOS SUMMARY
		Intelligence
		Maneuver
		Fire Support
		Air Defense/Airspace
		Mobility/Counter mobility/Survivability
		CSS
		C2
		Operational Risk Assessment
		Recommendation

**Figure J-3. Recommendation GO/NO GO air assault chart.**

**J-11. AIR ASSAULT BATTALION TASK FORCE KEY PERSONNEL**

The battalion task force staff is responsible for planning the air assault operation and the accompanying battalion task force (-) operations, developing the air assault in conjunction with the assault helicopter unit, synchronizing all elements of the combined-arms team, and allocating the necessary resources to the air assault task force (AATF) to ensure successful execution of the operation.

a. **Air Assault Task Force Commander.** The air assault task force commander (AATFC) is normally the battalion task force commander. He has overall responsibility for the AATF’s planning and execution. The brigade commander may elect to assume this role.

b. **Air Mission Commander.** The supporting helicopter unit provides an air mission commander (AMC). For air assaults conducted by a company from the general support aviation battalion, the aviation battalion commander may designate an aviation company commander or aviation platoon leader to be the AMC.

c. **Aviation Liaison Officer.** The supporting aviation unit should provide an aviation liaison officer to the AATF. The ALO should be considered a special staff officer in the AATF. The role of the ATO is to advise the AATFC on all matters relating to Army aviation and to jointly develop, along with the AATF staff, the detailed plans necessary to support the air assault operation. During the execution phase, the ALO should be available to assist the AATFC or the S3 in coordinating the employment of aviation assets.

**J-12. AIR ASSAULT ROLES**

Utility helicopters and cargo helicopters are the primary aircraft used in air assault operations.

a. **Utility Helicopters.** The primary mission of the utility helicopter (UH) in the air assault is to move troops. With the seats installed, the allowable cargo load (ACL) for the UH-60 is 11 combat-loaded soldiers. If the seats are removed, the ACL increases. (The ACL then will depend on the type equipment being carried by the soldiers.) For planning



purposes, a UH-60 has an ACL of--and is capable of transporting--approximately 16 combat-loaded troops.

b. **Cargo Helicopters.** The cargo helicopter also provides the AATF with the capability of moving troops and equipment in support of the air assault. In a troop-carrying mode, the CH-47D's ACL is approximately 31 combat-loaded troops.

### J-13. GROUND TACTICAL PLAN

The foundation of a successful air assault is the ground tactical plan. All other air assault planning stages are based on the ground tactical plan, which specifies actions in the objective area that will lead to accomplishment of the mission. The ground tactical plan addresses the following areas:

- Missions of all task force elements and methods for employment.
- Areas of operations with graphic control measures.
- Task organization to include command relationships.
- Location and size of reserves.
- Fire support to include graphic control measures.
- Combat service support.

**NOTE:** The AATF staff prepares the ground tactical plan with input from all task force elements and in sufficient detail to facilitate understanding by subordinate commanders. It is imperative that all aircrews know the ground tactical plan and the ground commander's intent.

a. **Commander's Intent.** The AATFC must articulate his intent for the air assault early in the planning process. Air assault planning often begins after the AATFC issues his intent even though the ground tactical plan may not be complete. The commander's intent for the air assault allows air assault planners to understand the method and end state and to begin to piece together the subsequent plans. The commander's intent for the air assault includes items such as whether the assault force will land on the objective or land near it in order to be able to maneuver to the objective. The commander's intent for the air assault may include surprise as a critical element, which leads to the development of both the FS and SEAD plans.

b. **Organization for Combat.** The mission, enemy situation, terrain, maneuver forces, and fire support assets all help air assault planners determine the task force organization for combat. Planners emphasize--

- Maximizing combat power in the assault to heighten surprise and shock effect. This is especially important if the air assault force plans to land on or near the objective.
- Ensuring the TF inserts enough force to accomplish initial objectives quickly. The air assault force must be massed in the LZ and build up significant combat power early to prevent being defeated by repositioning mobile enemy forces.
- Ensuring the air assault force has sufficient assets to sustain it until linkup.

c. **Scheme of Maneuver.** The AATFC develops a scheme of maneuver to accomplish his mission and seize assigned objectives. Scheme of maneuver development by the TF headquarters allows subsequent planning phases of the air assault to be

accomplished and must be done prior to development of the air assault. Development of the TF ground tactical plan need not be complete to begin air assault mission planning. As a minimum, the AATFC must provide the ground scheme of maneuver for air assault planning to begin. TF planners should not wait for the completed assault force OPORD to begin planning. The TF staff and aviation units can begin air assault planning as soon as the assault force commander approves the general scheme of maneuver.

d. **Fire Support.** The amount of artillery available to support the air assault and the locations of supporting artillery units are critical factors in determining the ground tactical plan.

e. **Attack Helicopters in Support of the Ground Tactical Plan.** During the ground fight, attack helicopters may assist the assault force commander by providing reconnaissance in the vicinity of the LZs, destroying repositioning forces, destroying counterattacking forces, and calling for and adjusting fire on targets of opportunity. A shift in C2 from the AMC to the assault force commander is critical and must be planned and rehearsed in detail. During an air assault with multiple lifts, the attack helicopters support both the air assault and ground fight. (Some elements provide reconnaissance and security for the air assault; other elements screen for the assault force.) Synchronization of the attack assets must be precise and detailed to eliminate confusion and to avoid disrupting the air assault flow.

#### J-14. LANDING PLAN

The scheme of maneuver and the ground tactical plan directly affect the selection of LZs, the landing formation, and the amount of combat power air assaulted into the LZ. The landing plan must be planned in conjunction with the development of the ground tactical plan and must support the assault force commander's intent and scheme of maneuver. The landing plan outlines the distribution, timing, and sequencing of aircraft into the LZ.

a. **Landing Zone Selection.** In coordination with the AMC and LNO, the AATFC selects primary and alternate LZs. The number of selected LZs is based on the ground scheme of maneuver and LZ availability. The aviation planners advise the AATFC on LZ suitability. The considerations for selecting suitable landing zones include the following.

(1) **Location.** The LZ must be in an area supporting the ground tactical plan of the AATFC. It may be located on the objective, close by, or at a distance.

(2) **Capacity.** The selected LZ must be big enough to support the number of aircraft the AATFC requires on air assault lifts.

(3) **Enemy Disposition and Capabilities.** The AMC must consider enemy air defense locations and weapons ranges and the ability of the enemy to reposition ground forces to react to the air assault.

(4) **Unit Tactical Integrity.** Squads land in the LZ intact, and platoons land in the same serial. This ensures fighting unit integrity during the air assault.

(5) **Supporting Fires.** LZs selected must be in range of supporting fires (artillery, CAS, and NGF).

(6) **Obstacles.** LZ selection includes existing obstacles on the LZ as well as plans for reinforcing them. LZs should be selected beyond enemy obstacles.

(7) **Identification from the Air.** The LZ should be identifiable from the air if possible.

b. **Attack and Air Cavalry Helicopters in Support of the Landing Plan.** During execution of the landing plan, the attack and air cavalry helicopters can provide overwatch of the LZs, conduct a reconnaissance of the egress flight routes, call for fire (if designated to do so), and set up a screen for supporting the assault force commander during the ground tactical plan. The AMC must ensure the missions of the attack and cavalry aircraft are synchronized with the assault helicopters.

#### **J-15. AIR MOVEMENT PLAN**

The air movement plan is based on the ground tactical and landing plans. It specifies the schedule and provides instructions for the movement of troops, equipment, and supplies from the PZ to the LZ. It provides coordinating instructions regarding air routes, air control points, aircraft speeds, altitudes, formations, and FS. The AATFC develops the air movement plan in conjunction with the AMC and flight lead. The air movement plan results in the production of the air movement table.

a. Selection of flight routes is always based on the factors of METT-TC. The AATF staff and the AMC consider the location of friendly troops, enemy disposition, air defense systems, terrain, and the locations of the PZ and LZ to select the best flight route. Selected flight routes should always be laid over the enemy situational template produced by the S2 to ensure the flight route selected avoids known or suspected enemy positions.

b. The AATF staff and the AMC select primary and alternate flight routes. Alternate flight routes provide the assault force a preplanned, precoordinated method of moving from the PZ to LZ if the primary route becomes compromised.

c. Flight routes that pass through adjacent unit sectors must be coordinated and approved by the adjacent unit to avoid potential fratricide.

d. When selecting flight routes, the AMC and AATF staff must consider--

- Airspace management.
- Support of the landing plan.
- Enemy capabilities.
- Fire support.
- Flight route distance.

e. Attack and air cavalry helicopters can be used in support of the air movement plan. During the air movement phase, the air assault security forces provide reconnaissance and security for the assault helicopters.

#### **J-16. LOADING PLAN**

The AATFC bases the loading plan on the air movement and ground tactical plans. The loading plan ensures troops, equipment, and supplies are loaded on the correct aircraft. It establishes the priority of loads, the bump plan, and the cross-loading of equipment and personnel. Detailed load planning ensures the AATF arrives at the LZ configured to support the ground tactical plan. A bump plan ensures essential troops and equipment are loaded ahead of less critical loads in case aircraft are lost during the air assault. Planning for the loading plan must include the organization and operation of the PZ, the loading of aircraft, and the bump plan.

a. **Pickup Zone Selection.** The first step in the loading plan is selection of suitable primary and alternate PZs. Selection of PZs is based on—

- METT-TC.
- Commander's intent.
- Location of assault forces in relation to PZs.
- Size and capabilities of available PZs.
- Number of PZs.
- Proximity to troops.
- Accessibility.
- Vulnerability to attack.
- Surface conditions.

b. **Pickup Zone Control.** Once the AATFC selects the PZ, the PZ control officer (PZCO) organizes, controls, and coordinates PZ operation.

c. **Aviation Involvement.** The assault helicopter unit must ensure aviation expertise is present on the PZ.

d. **Pickup Zone Communications.** Communications must use the most secure means available. PZ operations may be conducted under radio listening silence to avoid electronic detection. This requires detailed planning. If under radio listening silence, it is imperative that aircrews remain on schedule to allow the PZCO to maintain a smooth flow of troops from the PZ. PZ communications are accomplished on the established PZ control net, with FM transmissions kept to a minimum.

e. **Pickup Zone Marking.** The PZCO directs the marking of the PZ so it is identifiable from the air. Far and near recognition signals are needed, especially at night, to allow pilots to orient on the PZ quickly. Touchdown points must be clearly marked. The PZCO must ensure no other lighting is on the PZ.

f. **Disposition of Loads on the Pickup Zone.** Personnel and equipment must be positioned on the PZ to conform to the landing formation. Flight crews must understand the loading plan on the PZ and be prepared to accept troops and equipment immediately upon landing. PZ sketches depicting locations of loads in the PZ assist flight crews in loading troops and equipment quickly once the aircraft arrive in the PZ. Flight crews should be provided a PZ diagram.

g. **Attack and Air Cavalry Helicopters in Support of the Loading Plan.** During the loading phase, the attack and air cavalry helicopters assist by providing overwatch of the PZs and conducting a route reconnaissance of the air assault flight routes.

## J-17. STAGING PLAN

The staging plan is based on the loading plan and prescribes the proper order for movement of personnel and aircraft to the PZ. Loads must be ready before the aircraft arrive at the PZ. During mission planning, the PZCO determines the time required to set up the PZ and selects times the PZ will be established (based upon the air assault H-hour).

a. **Mission Planning.** Mission planning includes coordination between the AATF and the AMC, development of the aviation OPOD, issuance of the OPOD, and rehearsals.

b. **Routes to the Pickup Zone.** The AMC must select flight routes to the PZ that allow the aircraft to arrive at the PZ on time and in the proper landing direction and configuration to accept loads.

# GLOSSARY

1SG	first sergeant
A&O	assault and obstacle
A2C2	Army airspace command and control
AA	assembly area (graphics); avenue of approach
AAR	after-action review
AATF	air assault task force
AATFC	air assault task force commander
AB	aviation brigade (graphics)
ABCS	Army Battle Command System
ABF	attack by fire
ABMOC	air battle management operations center
AC	Active Component
ACA	airspace coordination area
ACE	armored combat earthmover
ACF	aviation close fires
ACIPS	Army casualty information processing system
ACL	allowable cargo load
ACM	airspace coordination measure
ACP	air controlpoint
ACT	analysis and control team
ACUS	Army common user system
AD	air defense
ADA	air defense artillery
ADAM	area denial artillery munition
ADC	area damage control; analog-to-digital converter
ADDS	Army data distribution system
ADO	air defense officer
ADW	air defense warning
AFATDS	advanced field artillery tactical data system
AFATDS-LCU	advanced field artillery tactical data system lightweight computer unit
AFCS	automatic fire control system
AGCCS	Army global command and control system
AGM	attack guidance matrix
AHD	antihandling device
AI	area of interest
A/L	administrative/logistical
ALO	air liaison officer
ALOC	administrative/logistical operations center
AM	amplitude modulation
AMB	air mission brief
AMC	air mission commander
AMDWS	air and missile defense workstation

AMPS	aviation mission planning system
ANCD	automatic net control system
AO	area of operations
AOE	Army of Excellence
AP	antipersonnel
APC	armored personnel carrier
APOD	aerial port of debarkation
APOE	aerial port of embarkation
AR	armor
ARFOR	Army forces
ARSOF	Army special operations force
AS	autonomous system
ASA	aviation support area (graphics)
ASAS	all-source analysis system
ASAS-RWS	all-source analysis system remote workstation
ASL	authorized stockage list
ASMC	aviation support maintenance company (graphics)
ASOC	air support operations center
ASP	ammunition supply point
AT	antitank
ATACMS	Army tactical missile system
ATCCS	Army tactical command and control system
ATGM	antitank guided missile
ATM	advanced trauma management
ATO	air tasking order
ATP	ammunition transfer point (graphics)
ATS	air traffic services
AVIM	aviation intermediate maintenance (graphics)
AVLB	armored vehicle-launched bridge
AVLM	armored vehicle-launched mine clearing line charge
AWACS	airborne warning and control system
AXP	ambulance exchange point
BALO	brigade air liaison officer
BAS	battalion aid station
BAT	brilliant antitank technology
BBDPICM	base-burn dual-purpose improved conventional munitions
BCIS	battlefield combat identification system
BCT	brigade combat team
BDA	battle damage assessment
BDAR	battle damage assessment and repair
BDE	brigade
BDO	battledress overgarment
BFV	Bradley fighting vehicle
BHL	battle handover line
BICC	battlefield information control center

---

BMNT	beginning morning nautical twilight
BMO	battalion maintenance officer
BN	battalion
BOS	battlefield operating systems
BP	battle position
BRT	brigade reconnaissance troop
BSA	brigade support area
BSB	base support battalion
BSC	base support company
BSFV	Bradley Stinger fighting vehicle
BUA	built-up area
C2	command and control
C3	command, control, and communications
C3I	command, control, communications, and intelligence
C4	command, control, communications, and computers
C4I	command, control, communications, computers, and intelligence
C4ISR	command, control, communications, computers, intelligence, surveillance, and reconnaissance
CA	civil affairs
CAFAD	combined arms for air defense
CAS	close air support
CASEVAC	casualty evacuation
CATK	counterattack
CBRNE-CM	chemical, biological, chemical, radiological, nuclear, and high-yield explosive consequence management
CBT	combat trains (graphics)
CCIR	commander's critical information requirements
CCP	casualty collection point
CDE	chemical detection equipment
CDR	commander
CFF	call for fire
CFZ	call for fire zone
CFL	coordinated fire line
CFS	call for support
CFZ	critical friendly zone
CGS	common ground station
cGy	centigray; center of gravity
CHEMO	chemical officer
CI	counterintelligence
CIP	combat identification panel
CLS	combat lifesaver
CMO	civil-military operations
CMOC	civil-military operations center
CMT	company maintenance team
CNR	combat net radio

CNRI	combat net radio interface
Co	company (graphics)
COA	course of action
COMSEC	communications security
CONUS	continental United States
COP	common operational picture
COSCOM	corps support command
CP	command post
CPT	captain
CRT	combat repair team
CS	combat support
CSAR	combat search and rescue
CSM	command sergeant major
CSR	controlled supply rate
CSS	combat service support
CSSCS	combat service support control system
CSE	combat support engineer
CTCP	combat trains command post
CTIL	commander's tracked item list
CZ	sensor zone
D3A	decide, detect, deliver, and assess
DA	Department of the Army
DAO	division ammunition officer
DART	disaster assistance response team (graphics)
DASR	division aviation support battalion
DED	detailed equipment decontamination
DIMHRS	defense integrated military human resources system
DISCOM	division support command
DIV	division
DLIC	detachment left in contact
DMOS	duty military occupational specialty
DOD	Department of Defense
DP	decision point
DPICM	dual-purpose improved conventional munitions
DS	direct support
DSA	division support area
DSB	division support battery
DSO	domestic support operation
DSSU	dismounted soldier system unit
DST	decision support template
DSVT	digital secure voice telephone
DTD	detailed troop decontamination
DTO	data terminal operator
DTSS	digital terrain support system
DVNT	digital voice nonsecure telephone



---

DZ	drop zone
EA	engagement area
EAD	echelons above division
EBA	engineer battlefield assessment
EBC	embedded battle command
ECB	echelons corps and below
EOCA	enemy course of action
ECOORD	effects coordinator
EEFI	essential elements of friendly information
EENT	ending evening nautical twilight
EFST	essential fire support task
EMST	essential mobility/survivability task
EMT	emergency medical treatment
EO	electrooptical
EOD	explosive ordnance disposal
EPLRS	enhanced position location reporting system
EPW	enemy prisoner of war
ER-DPICM	extended-range dual-purpose improved conventional munitions
ER-MLRS	extended-range multiple-launched rocket system
ETAC	enlisted tactical air controller
ETM-I	electronic technical manual-interface
EW	electronic warfare
FA	field artillery
FAADC3I	forward area air defense command, control, computers, and intelligence
FAC	forward air controller
FARP	forward arming and refueling point
FASCAM	family of scatterable mines
FBCB2	Force XXI battle command brigade and below
FBI	Federal Bureau of Investigation
FCR	fire control radar
FDC	fire direction center
FDO	fire direction officer
FEBA	forward edge of the battle area
FFAR	fikdung-fin aerial rocket
FFIR	friendly forces information requirements
FHA	foreign humanitarian assistance
FID	foreign internal defense
FIST	fire support team
FLD	field (graphics)
FLE	forward logistics element
FLIR	forward-looking infrared
FLO	fighter liaison officer
FLOT	forward line of own troops

FM	field manual; frequency modulated
FMTV	family of medium tactical vehicles
FO	forward observer
FOS	forward observer system
FPF	final protective fires
FRAGO	fragmentary order
FS	fire support
FSB	forward support battalion
FSC	forward support company
FSCL	fire support coordination line
FSCM	fire support coordination measure
FSCOOD	fire support coordinator
FSE	fire support element
FSEM	fire support execution matrix
FSG	family support group
FSMC	forward support medical company
FSMT	forward support medical evaluation team
FSO	fire support officer
FST	forward surgical team
FTCP	field trains command post
FTL	far target locator
FU	firing unit
G2	assistant chief of staff (intelligence)
G3	assistant chief of staff (operations and plans)
GBS	ground-based sensor
GCSS-A	global combat support system-Army
GEMSS	ground-emplaced mine scattering system
GLAD	grenade launcher attachment development
GMLRS	guided multiple-launched rocket system
GPS	global positioning system
grp	group
GS	general support
GSR	ground surveillance radar
G/VLLD	ground/vehicle laser locator designator
HAZMAT	hazardous materials
HCA	humanitarian and civic assistance
HCP	health care package
HDC	headquarters and distribution company
HE	high-explosive
HET	heavy equipment transport
HEMTT	heavy expanded mobility tactical truck
HF	high frequency
HHC	headquarters and headquarters company
HIMAD	high- to medium-altitude air defense

---

HIMARS	high-mobility artillery rocket system
HMMWV	high-mobility, multipurpose wheeled vehicle
HPT	high-payoff target
HQ	headquarters
HSC	headquarters and supply company (graphics)
HSS	health service support
HTU	handheld terminal unit
HUMINT	human intelligence
HVT	high-value target
IAW	in accordance with
ICM	improved conventional munitions
ICW	in coordination with
ID	identification
IDMM	isolate, dominate, maintain, multidimensional-multiecheloned
IEW	intelligence and electronic warfare
IFF	identification, friend or foe
IHFR	improved high-frequency radio
IM	information management
IMETS	integrated meteorological system
INC	interface network controller
INFOSYS	information systems
INS	inertial navigation system
IO	information operation
IPB	intelligence preparation of the battlefield
IR	information requirements; infrared
ISSO	information services support
ISR	intelligence, surveillance, and reconnaissance
ITAPDB	integrated total Army personnel database
J2	joint staff (intelligence)
JAAT	joint air attack team
JAG	judge advocate general
JCDB	joint common database
JCS	Joint Chiefs of Staff
JFC	joint force commander
J-SEAD	joint suppression of enemy air defense
JSTARS	joint surveillance target attack radar system
JTF	joint task force
JTIDS	joint tactical information distribution system
KIA	killed in action
km	kilometer
KCLFF	kitchen company-level field feeding (graphics)
LADW	local air defense warning

LAN	local area network
LCD	limited conversion design
LD	line of departure
LMTV	light-medium tactical vehicle
LNO	liaison officer
LOA	limit of advance
LOC	line of communication
LOG	logistics
LOGPAC	logistics package
LOGSITREP	logistics situation report
LOGSTAT	logistics status
LOR	limits of reconnaissance
LOS	line of sight
LRF	laser range finder
LRF/D	laser range finder/designator
LRP	logistics release point
LRS	long-range surveillance
LRU	line replacement unit
LSDIS	light and special divisions interim sensor
LTIOV	last time information is of value
LZ	landing zone
MAC	mine action center
MANPADS	man-portable air defense system
MARC	manpower requirements criteria
MBA	main battle area
MCOO	modified combined obstacle overlay
MCS	maneuver control system; maintenance control section
MDMP	military decision-making process
MEDEVAC	medical evacuation
MEDLOG	medical logistics
MET	meteorological
METL	mission-essential task list
METSAT	meteorological satellite
METT-TC	mission, enemy, terrain and weather, troops and support available, time available, and civil considerations
MGB	medium-girder bridge
MGRS	military grid reference system
MI	military intelligence
MICLIC	mine clearing line charge
MKT	mobile kitchen trailer
MLC	military load classification
MLRS	multiple-launched rocket system
mm	millimeter
MMMB	medical material management branch
MMS	mast-mounted sight

---

MOOTW	military operations other than war
MOPMS	modular pack mine system
MOPP	mission-oriented protective posture
MOS	military occupational specialty
MP	military police
MRE	meals, ready to eat
MSB	main support battalion
MSE	mobile subscriber equipment
MSR	main supply route
MSRT	mobile subscriber radio telephone
MST	maintenance support team (graphics)
MSTAR	multiple-launched rocket system smart tactical rocket
MTF	medical treatment facility
MTS	movement tracking system
MTW	major theater of war
MWR	morale, welfare, and recreation
NAI	named area of interest
NBC	nuclear, biological, chemical
NBCWRS	nuclear, biological, chemical warning and reporting system
NC	node center
NCA	national command authority
NCO	noncommissioned officer
NCOIC	noncommissioned officer in charge
NCS	net control station
NEO	noncombatant evacuation operation
NFA	no-fire area
NG	National Guard
NGF	naval gunfire
NGO	nongovernmental organization
NIMA	National Imagery Mapping Agency
NLT	no later than
NOE	nap-of-the-earth
NORMA	nature of the target, obstacle clearance, range to target, multiple firing positions, adequate area for proper dispersion between aircraft
NTDR	near-term digital radio
NVG	night-vision goggles
OB	order of battle
OBJ	objective (graphics)
OBSTINTEL	obstacle intelligence
OCOKA	observation and fields of fire, cover and concealment, obstacles, key terrain, and avenues of approach
OEG	operational exposure guidance
OI	operations and intelligence

OIC	officer in charge
OP	observation post
OPCON	operational control
OPLAN	operation plan
OPLOG	operational logistics
OPORD	operation order
OPSEC	operational security
OPTEMPO	operational tempo
ORL	ordnance release line
P3I	preplanned product improvement
PA	public affairs; physician assistant
PAC	personnel and administrative center
PAI	personnel asset inventory
PAO	public affairs officer
PCI	precombat inspection
PEO	peace enforcement operation
PERSITREP	personnel situation report
PI	product improvement
PIR	priority intelligence requirements
PKO	peacekeeping operation
PL	phase line
PLGR	precision lightweight GPS receiver
PLL	prescribed load list
PMCS	preventive maintenance checks and services
PME	peacetime military engagement
PO	peace operations
POD	port of debarkation
POE	point of embarkation
POL	petroleum, oil, lubricants
POSNAV	position navigation
POV	personally owned vehicle
PP	passage point
PSD	personnel service detachment
PSG	platoon sergeant
PSS	personnel service support
PSYOP	psychological operations
PVNTMED	preventive medicine
PVO	private volunteer organization
PZ	pickup zone
PZCO	pickup zone control officer
QRF	quick reactionary force
R&S	reconnaissance and surveillance
RA	routing area

---

RAAM	remote antiarmor mine
RAP	rocket-assisted projectile
RATELO	radiotelephone operator
RAU	radio access unit
RC	reserve component
REMBASS	remotely monitored battlefield sensor system
Retrans	retransmission
RF	radio frequency
RFI	requests for intelligence or information
RFL	restricted fire line
RI	relevant information
RSTA	reconnaissance, surveillance, and target acquisition
ROE	rules of engagement
ROI	rules of interaction
ROM	refuel on the move
RP	release point
RPG	rocket-propelled grenade
RPV	remotely piloted vehicle
RS	radio set
RSOI	reception, staging, onward movement, and integration
RWS	remote workstation
S&T	supply and transportation
S1	adjutant
S2	intelligence officer
S3	operations and training officer
S3 air	assistant S3, air operations
S4	logistics officer
S5	civil affairs officer
S6	communications staff officer
SADARM	sense and destroy armor
SAMS	standard Army maintenance system
SARSS	standard Army retail supply system
SBF	support by fire
SCATMINE	scatterable mine
SCATMINEWARN	scatterable minefield warning
SCT	scout (graphics)
SD	self-destruct
SEAD	suppression of enemy air defense
SEE	small emplacement excavator
SEN	small extension node
SFC	sergeant first class
SGM	sergeant major
SGT	sergeant
SHORAD	short-range air defense
SIDPERS	standard installation/division personnel system

SIGINT	signal intelligence
SINCGARS	single-channel ground and air radio system
SIP	system improvement plan
SIR	specific information requirements
SITREP	situation report
SITTEMP	situation template
SIV	systems integration vehicle
SOEO	scheme of engineer operations
SOF	special operations force
SOI	signal operating instructions
SOP	standing operating procedure
SOR	specific orders and requests
SOSRA	suppress, obscure, secure, reduce, and assault
SP	start point
SPBS-R	standard property book system-redesign
SPLL	self-propelled loader-launcher
SPO	support operations officer
SPOE	seaport of embarkation
SPOD	seaport of debarkation
SPOTREP	spot report
SRP	soldier readiness preparations
SSC	small-scale contingency
STAMIS	standard Army management information system
STRIKEWARN	friendly strike warning
SVML	standard vehicle mounted launcher
TA	target acquisition
TACAIR	tactical air
TACCS	tactical air command and control specialist
TACP	tactical air control party
TACSAT	tactical satellite
TAI	target area of interest
TALO	theater airlift liaison officer
TAMMS	the Army maintenance management system
TC-AIMS	transportation coordinator's automated information for movement system
TCF	tactical combat force
TDA	target damage assessment
TDIS	time and distance
TEP	theater engagement plan
TEWT	tactical exercise without troops
TF	task force
TFSA	task force support area
TI	tactical internet
TIM	toxic industrial materials
TIO	tactical intelligence officer



---

TIS	thermal imaging sensor
TIRS	terrain index reference system
TLP	troop-leading procedures
TM	team (graphics)
TMD	theater missile defense
TOC	tactical operations center
TOE	table of organization and equipment
TOW	tube-launched, optically tracked, wire-guided
TPFDDL	time-phased force and deployment data list
TPL	time phase line
TPN	tactical packet network
TPS	tactical personnel system
TRP	target reference point
TSOP	tactical standing operating procedure
TTP	tactics, techniques, and procedures
TVS	television sensor
UAV	unmanned aerial vehicle
UGR-A	unitized group ration-A
UGR-B	unitized group ration-B
UHF	ultra high frequency
ULLS	unit-level logistics system
ULLS-G	unit-level logistics system-ground
UMCP	unit maintenance collection point
UN	United Nations
UO	urban operations
US	United States
USAF	United States Air Force
UTO	unit task organization
UXO	unexploded ordnance
VHF	very high frequency
VHSIC	very high-speed integrated circuits
VMF	variable message format
VT	variable time
WAN	wide area network
WARNO	warning order
WCS	weapons control status
WIA	wounded in action
WMD	weapon of mass destruction

WP	white phosphorus
WSRO	weapons system replacement operations
XO	executive officer
ZOR	zone of responsibility

# REFERENCES

## SOURCES USED

*These are the sources quoted or paraphrased in this publication.*

- AR 40-3 Medical, Dental, and Veterinary Care. 30 July 1999.
- FM 1-112 (3-04.112) Attack Helicopter Operations. 2 April 1997.
- FM 1-111 (3-04.111) Aviation Brigades (and Digital Annex). 27 October 1997.
- FM 3-0 Operations. 14 June 2001.
- FM 3-06.11 Combined Arms Operations in Urban Terrain. 28 February 2002.
- FM 3-3 Chemical and Biological Contamination Avoidance. 16 November 1992.
- FM 3-5 (3-11.5) NBC Decontamination. 28 July 2000. Change 1, 31 January 2002.
- FM 3-07 (100-20) Stability Operations and Support Operations. 20 February 2003.
- FM 3-19.40 Military Policy Internment/Resettlement Operations. 1 August 2001.
- FM 3-20.15 (17-15) Tank Platoon. 1 November 2001.
- FM 3-34.2 Combined Arms Breaching Operations. 31 August 2000. Change 1, 15 November 2000.
- FM 3-34.230 (5-105) Topographic Operations. 3 August 2000.
- FM 3-90 Tactics. 4 July 2001.
- FM 3-90.1 Tank and Mechanized Infantry Company Team. 9 December 2002.
- FM 3-90.3 The Mounted Brigade Company Team. 1 November 2001.
- FM 3-100.4 Environmental Considerations in Military Operations. 15 June 2000. Change 1, 11 May 2001.
- FM 4-02.4 Medical Platoon Leaders' Handbook Tactics, Techniques, and Procedures. 24 August 2001.

FM 4-02.7 (8-10-7) Health Service Support in a Nuclear, Biological, and Chemical Environment. 1 October 2002.

FM 5-71-2 (3-34.222) Armored Task Force Engineer Combat Operations. 28 June 1996. Change 1, 13 November 1997.

FM 5-100 (3-34) Engineer Operations. 27 February 1996.

FM 5-102 (3-34.1) Countermobility. 14 March 1985.

FM 5-103 (3-34.112) Survivability. 10 June 1985.

FM 5-104 (3-34.112) General Engineering. 11 December 1986.

FM 6-20-10 (3-60) Tactics, Techniques, and Procedures for the Targeting Process. 8 May 1996.

FM 6-20-40 (3-09.4) Tactics, Techniques, and Procedures for Fire Support for Brigade Operations (Heavy). 5 January 1990.

FM 6-22.5 (22-9) Combat Stress. 23 June 2000.

FM 7-0 Training the Force. 22 October 2002.

FM 7-10 The Infantry Rifle Company. 14 December 1990.

FM 8-42 Combat Health Support in Stability Operations and Support Operations. 27 October 1997.

FM 12-6 (1-0) Personnel Doctrine. 9 September 1994.

FM 17-95 (3-20.95) Cavalry Operations. 24 December 1996.

FM 17-98 Scout Platoon. 10 April 1999.

FM 23-10 (3-22.10) Sniper Training and Employment. 17 August 1994.

FM 27-10 The Law of Land Warfare. 18 July 1956.

FM 34-1 (2-0) Intelligence and Electronic Warfare Operations. 27 September 1994.

FM 34-130 (2-01.3) Intelligence Preparation of the Battlefield. 08 Jul 94.

FM 41-10 (3-05.40) Civil Affairs Operations. 14 February 2000.

FM 44-8 (3-01.8) Combined Arms for Air Defense. 1 June 1999.

FM 55-10 Movement Control. 9 February 1999.

---

FM 3-90.3	The Mounted Brigade Company Team. 1 November 2001.
FM 71-100	Division Operations. 28 August 1996.
FM 90-7 (3-34.1)	Combined Arms Obstacle Integration. 29 September 1994. Change 1, 10 April 2003.
FM 90-10	Military Operations on Urban Terrain (MOUT) (How to Fight). 15 August 1979.
FM 90-13 (3-34.13) (MCWP 3-17.1)	River-Crossing Operations. 26 January 1998.
FM 90-4 (3-18.12)	Air Assault Operations. 16 March 1987.
FM 100-7 (3-93)	Decisive Force: The Army in Theater Operations. 31 May 1995.
FM 100-14 (5-19)	Risk Management. 23 April 1998.
FM 100-19	Domestic Support Operations. 1 July 1993.
FM 101-5 (5-0)	Organization and Operations. 31 May 1997.
FM 101-5-1 (1-02) (MCRP 5-2A)	Operational Terms and Graphics. 30 September 1997.
JP 1-02	Department of Defense Dictionary of Military and Associated Terms. June 1999.
JP 3-07	Joint Doctrine for Military Operations Other Than War. 16 June 1995.
JP 3-07.1	Joint Tactics, Techniques, and Procedures for Foreign Internal Defense. 26 June 1996.
JP 3-07.3	Joint Tactics, Techniques, and Procedures for Peace Operations. 12 February 1999.
JP 3-35	Joint Deployment and Redeployment Operations. 7 September 1999.
JP 4-05	Joint Doctrine for Mobilization Planning. 22 June 1995.
PL 93-288	Federal Response Plan for Public Law 93-288, as amended.
STP 19-95B1-SM	Soldier's Manual, MOS 95B, Military Police, Skill Level 1. 21 February 1997.

10 USC 401, 401 (e)(5) Humanitarian and Civic Assistance Provided in Conjunction with Military Operations.

10 USC 2551 Humanitarian Assistance.

**DOCUMENTS NEEDED**

*These documents must be available to the intended users of this publication.*

DA Form 5368-R Quick Fire Plan. December 1984.

DA Form 5988-E Equipment Inspection Maintenance Worksheet. March 1991.

**INTERNET SOURCES USED**

*The following Internet sources were used in the preparation of this manual.*

U. S. Army Publishing Agency, <http://www.usapa.army.mil>

Army Doctrine and Training Digital Library, <http://www.adtdl.army.mil>

## INDEX

- ABCS (see Army battle command system)
- air assault operations, J-1 through J-9
  - air movement plan, J-8
  - ground plan, J-6
  - landing plan, J-7
  - mission analysis, J-1
  - planning, by BOS, J-2
    - stages, J-3 through J-10;
    - J-4 (illus); J-5 (illus)
- air defense
  - assembly area, support, 12-43
  - attack, support, 5-37; 5-46
  - combat support, 9-46 through 9-53
    - architecture, 9-47 (illus)
    - assets, 9-52
    - defense, considerations, 9-51
    - offense, considerations, 9-51
    - organization, 9-47; 9-48 (illus)
    - planning considerations, 9-48 through 9-50
    - types, 9-51
    - warnings, 9-51
    - weapons control status, 9-51
  - defensive operations, 6-10
  - delay, 6-28
  - guard, 4-21; 12-7
  - heavy/light forces integration, A-6
  - movement to contact, 5-29
  - occupation, assembly area, 12-43
  - stability operations, 8-18
  - support operations, 8-38
- air defense artillery
  - air assault operations, J-3
  - movement to contact, 5-24
  - passage of lines, 12-13
  - strongpoint defense, 6-56
- air defense officer
  - close air support, 9-35
  - duties, combat support, 9-50
  - special staff, responsibilities, 2-17
- air defense warnings, 9-51; 9-52 (illus)
- Air Force
  - close air support, 9-32
  - movement to contact, 5-24
- air liaison officer, responsibilities, 2-17
- AO (see area of operations)
- Apache helicopters, B-5; B-6 (table); B-24
- approach march technique, movement to contact, 5-22 through 5-24
- area defense, 6-5 through 6-19
  - aviation support, B-3
  - defense in depth, 6-6; 6-7 (illus)
  - forward defense, 6-5; 6-6 (illus)
  - planning (see individual BOS entries), 6-7 through 6-12
  - preparation, 6-12 through 6-19
- area of operations (AO)
  - defense of, 6-44 through 6-47; 6-45 (illus)
  - defined, 1-6
  - delay, 6-22
  - extended, defensive operations, 6-17 through 6-19
  - movement into, 8-42
  - urban operations, contiguous and noncontiguous, 7-2
- Army battle command system (ABCS)
  - components, 11-14 through 11-17
- attack, 5-34 through 5-55
  - aviation support, B-2
  - characteristics, 5-35
  - movement to contact, maneuver option, 5-33
  - special purpose attacks, (see individual entries) 5-35 through 5-55
  - urban operations, 7-23 through 7-27; nodal, 7-29 through 7-31 (illus) village, 7-29 (illus)
- Avenger, 9-53
- aviation support, B-1 through B-25
  - air-ground coordination procedures, B-7 through B-15; B-8 (table); B-9 (table); B-11 (table); B-13 (illus)
  - defense, planning, 6-10

- defensive operations, B-3
- employment considerations, B-15
  - through B-18
- marking methods, B-17 (table)
- missions, B-1
- reconnaissance, B-4
- retrograde operations, B-6
- rotary-wing aircraft, B-5; B-6
  - (table)
- security, B-5
- stability operations, considerations, 8-16
- urban operations, support, B-19
  - through B-25; B-21 through B-23 (illus)
- battle handover
  - defensive operations, 6-14; 6-43
  - tactical enabling operation, 12-9
- battle position
  - selection, strongpoint defense, 6-54
  - technique, defensive operations, 6-47
    - (illus) through 6-49
    - levels of preparation, 6-47
    - maneuver, 6-48
    - types, 6-48
  - urban operations, defense, 7-36
- battlespace, defined, 1-7
- Bradley Linebacker, 9-52
- Bradley Stinger Fighting Vehicle, 9-52
- breach, 12-24 through 12-34
  - deliberate operations, 12-28 through 12-31
  - fundamentals (SOSRA), 12-25
  - hasty operations, 12-31 through 12-34
  - organization, 12-26 (illus)
  - tenets, 12-24
- bypass, movement to contact, maneuver option, 5-33
- C2 (see command and control)
- charts, planning and operations, examples, I-1 through I-20 (illus)
- civil concerns
  - defensive operations, 6-11
  - urban operations, considerations
    - based on METT-TC, 7-15
- classes of supply, 10-18 through 10-23; 10-19 through 10-22 (illus)
- close air support, combat support, 9-28; 9-30 through 9-36
  - Air Force support, 9-32
  - enemy air defense, suppression, 9-35
  - missions, 9-30 through 9-32 (illus)
  - planning, 9-32
  - weather, 9-36
- COA (see course of action)
- combat net radio, components, 11-10;
- combat service support (CSS), 10-1 through 10-42
  - air assault operations, J-3
  - assembly areas, support, 12-44
  - attack, support, 5-37; 5-46
  - defensive operations, planning, 6-11
  - delay, support, 6-28
  - field services, 10-23
  - forward support company (Force XXI) 10-9 through 10-12; 10-11 (illus); 10-12 (illus)
  - headquarters and headquarters company, (AOE), 10-7 through 10-9 (illus); 10-8 (illus)
  - heavy/light forces integration, A-6; A-11
  - legal services, 10-24
  - movement to contact, 5-24; 5-29
  - occupation, assembly area, 12-45
  - operations (see individual entries), 10-13 through 10-26
  - overview, 10-1 through 10-3
  - passage of lines, 12-13; 12-14 (illus)
  - perimeter defense, 6-58
  - planning, 10-26 through 10-41
    - command and control, 10-40
    - communications, 10-41
    - defensive operations, 10-32 through 10-34
    - LOGPAC, 10-37 through 10-40
    - offensive operations, 10-29 through 10-32
    - trains, 10-34 through 10-37



- postal services, 10-24
- reconstitution, 10-41
- religious support, 10-23
- responsibilities, 10-3 through 10-7
- stability operations, 8-18
- strongpoint defense, 6-56
- support operations, 8-38
- combat support (CS), 9-1 through 9-53
  - air defense (see separate entry), 9-46 through 9-53
  - close air support (see separate entry), 9-28; 9-30 through 9-36
  - engineers (see separate entry), 9-36 through 9-46
  - fire support (see separate entry), 9-1 through 9-30
  - movement to contact, 5-24
- command and control (C2)
  - air assault operations, J-3
  - assembly area, 12-43
  - combat service support, 10-40
  - command group, 3-7
  - digital techniques, 11-17 through 11-21
  - digitization, 3-6
  - execution, 3-24
  - heavy/light forces integration, A-4
  - occupation, 12-45
  - perimeter defense, 6-58
  - relief operations, 12-3
  - strongpoint defense, 6-56
  - support operations, 8-36
- commander
  - company team, 2-15
  - focus, 2-5
  - forward support company, 2-15
  - guidance, fires integration, G-1; G-2 (table)
  - headquarters and headquarters company, 2-15
  - location, 3-2
  - responsibilities, 2-5
  - role, MDMP, 3-12; 3-17
  - vision, defensive operations, 6-38
- command post
  - combat trains command post, 3-8; 11-2
  - field trains command post, 3-9; 11-3
  - forward support company command post, 3-9
  - main command post, 3-8; 11-2
  - operations, 11-1 through 11-24
    - C2 facilities, 11-1 through 11-5
    - communication, 11-7 through 11-14
    - digital architecture, 11-14 through 11-24
    - standing operating procedures, 11-5
- continuous operations, D-12 through D-14
  - effects, D-12; D-13 (table)
  - impact reduction, D-14 (table)
  - sleep denial, D-14
  - sleep deprivation, D-13 (table)
- counterattack (special purpose attack), 5-54
  - defensive operations, 6-17
  - delay, 6-31
  - technique, defensive operations, 6-58 through 6-60
- course of action (COA)
  - MDMP, 3-15; 3-19 through 3-22
- CS (see combat support)
- CSS (see combat service support)
- defend
  - movement to contact, maneuver option, 5-33
  - offensive transition, 5-56
- defense, 6-1 through 6-67
  - aviation support, B-3
  - countermobility, mobility, survivability (see also obstacles), 6-61 through 6-66
  - defined, 1-5
  - focus, 2-5
  - fundamentals, 6-1 through 6-5
  - heavy/light forces integration, A-8
  - main battle area, 6-2

- planning considerations, 6-37
  - through 6-41
- security area, 6-1
- sequence, 6-41 through 6-44
- snipers, F-6
- techniques, 6-44 through 6-60
- types of operations (see individual entries), 6-5 through 6-37
- urban operations, 7-31 through 7-37; 7-32 through 7-35 (illus); 7-37 (illus)
- delay, 6-20 through 6-32
  - aviation support, B-6
  - urban operations, 7-36; 7-37 (illus)
- demonstration (special-purpose attack), 5-54
- deployment, H-1 through H-6
- detachment left in contact, withdrawal, defensive operations, 6-33 (illus)
- enemy
  - air defense, suppression, close air support, 9-35
  - urban operations, analysis, METT-TC, 7-4 through 7-7; 7-5 (illus)
  - urban operations, focus, 7-16
- engineer
  - air assault operations, J-3
  - assembly area support, 12-43; 12-44; 12-45
  - attack, 5-36; 5-46
  - combat support, 9-36 through 9-46
    - assets, 9-42
    - assault and obstacle platoon, 9-41
    - engineer company, 9-40
      - commander, special staff, responsibilities, 2-17
    - engineering types, 9-39
    - maneuver support, 9-36 through 9-38
    - mobility, countermobility, survivability, 9-38
    - sapper platoon, 9-41
    - SCATMINES (see separate entry), 9-43 through 9-46
    - defensive operations, 6-9
    - delay, 6-28
    - guard, 4-21; 12-7
    - screen, 4-18; 12-4
    - stability operations, 8-17
    - strongpoint defense, 6-55
    - support operations, 8-38
    - urban operations, defensive operations, 7-36
  - environmental concerns, compliance, E-1 through E-15
    - assessment matrix, E-3 (illus); E-5 (illus); E-15 (illus)
    - impact values, E-4; E-8 through E-14 (illus)
    - rating, E-5; E-6 (illus)
    - risk, METT-TC-based, E-2 (table)
    - risk, reduction, E-6
  - executive officer (XO)
    - responsibilities, 2-6
    - role, MDMP, 3-13
  - exploitation, 5-51
    - aviation support, B-2
    - heavy/light forces integration, A-8
- feint (special-purpose attack), 5-53
- field artillery
  - combat support, 9-21 through 9-24; 9-21 (illus)
    - canon systems, 9-22
    - multiple-launched rocket systems, 9-22
    - responsibilities, 9-21
    - tactical Army missile system, 9-23
  - passage of lines, 12-13
- fire support
  - air assault operations, J-3
  - attack, support, 5-36; 5-45
  - combat support operations, 9-1 through 9-30
    - battle damage assessment, 9-13
    - clearance of fires, 9-17 through 9-19

- coordination, 9-14
- essential fires support tasks, 9-6 through 9-8 (table)
- field artillery, 9-21 through 9-24; 9-21 (illus)
- mortars, 9-24 through 9-28; 9-25 (illus); 9-26 (table)
- observation, 9-10 through 9-12
- overview, 9-1 through 9-3; 9-2 (table); 9-3 (table)
- planning, 9-3 through 9-6
- quick fire planning, 9-8 through 9-10
- radar zones, 9-19 through 9-21
- scheme of fires, 9-8
- defensive operations, 6-9
- delay, 6-27
- fire support officer, special staff, responsibilities, 2-16
  - close air support, 9-35
- guard, 4-21; 12-7
- heavy/light forces integration, A-5
- integration of fire support, G-1 through G-10
  - planning, G-2 through G-5
  - observation and target execution, G-5 through G-10; G-6 (table); G-7 through G-10 (illus)
- movement to contact, 5-28
- screen, 4-18; 12-4
- stability operations, 8-17
- strongpoint defense, 6-54; 6-55 (illus)
- support operations, 8-37
- urban operations, 7-19 (illus) through 7-21
- forward support company (Force XXI)
  - 10-9 through 10-12; 10-11 (illus); 10-12 (illus)
- fragmentary order (FRAGO)
  - intelligence, surveillance, reconnaissance, 4-5
  - MDMP, 3-22
- FRAGO (see fragmentary order)
- fratricide avoidance, D-6 through D-12
- considerations, D-9 through D-12 (tables)
- planning, preparation, D-7
- reduction measures, D-8
- stability operations, 8-12
- guard
  - advance, 4-19; 12-5
  - aviation support, B-5
  - flank, 4-20; 12-6
  - formation, movement techniques, 4-20
  - rear, 4-20; 12-6
  - support, 4-21; 12-7
- health service support
  - CSS, overview, 10-2
  - defensive operations, 6-11
  - passage of lines, 12-13
  - stability operations, 8-18
  - strongpoint defense, 6-56
  - support operations, 8-38
- heavy/light forces integration, A-1 through A-12
  - air assault, A-2; A-3
  - airborne, A-2, A-3
  - C2, A-4
  - CSS operations, A-11
  - defensive operations, A-8
  - exploitation, A-8
  - light infantry, A-2; A-3
  - missions, A-2 (table)
  - offensive operations, A-6 through A-8
  - retrograde, A-9
  - safety considerations, A-10
  - support, by BOS, A-5
- infiltration
  - maneuver, offensive, 5-11 through 5-13; 5-12 (illus)
- information systems (INFOSYS)
  - C2, 3-6
  - decision-making, 3-9
  - stability operations, 8-19
- INFOSYS (see information systems)

- intelligence (S2)
  - air assault operations, J-2
  - assembly area, support, 12-43
  - occupation, 12-44
  - responsibilities, 2-7
  - security screen, 12-4
  - stability operations, 8-37
  - support operations, 8-37
  - tactical intelligence officer, 2-8
- intelligence, surveillance,
  - reconnaissance (ISR) (see also reconnaissance), 4-1 through 4-29
  - collection management, 4-2 through 4-7; 4-6 (illus)
  - commander's critical information requirements, 4-2 (illus)
  - defensive operations, 6-38 through 6-40
  - enemy situation template, 4-15; 4-16 (illus)
  - MDMP, role, 3-13
  - movement to contact, 5-26
  - orders development, 4-12 through 4-14
  - overlay, 4-15
  - preparing for operations, 3-27
  - reconnaissance (see separate entry), 4-22 through 4-29
  - security operations (see separate entry), 4-17 through 4-22
  - support operations, 8-37
  - terrain management, 4-16
  - tiers of reconnaissance, 4-7; 4-8 (illus)
- ISR (see intelligence, surveillance, reconnaissance)
- Kiowa Warrior helicopter, B-5; B-6 (table)
- linkup, 12-16 through 12-20
- logistics (S4)
  - estimate, CSS, 10-27 through 10-29
  - guard, 4-21; 12-7
  - responsibilities, 2-10
  - screen, 4-18; 12-4
  - support platoon, 2-11
- logistics package (LOGPAC), CSS
  - operation, 10-37 through 10-40
- LOGPAC (see logistics package)
- maintenance
  - battalion maintenance officer, 2-11
  - defensive operations, CSS, 10-34
  - offensive operations, CSS, 10-30
- maneuver
  - air assault operations, J-2
  - assembly area, occupation, 12-45
  - assembly area, support, 12-43
  - battle positions, between, 6-48
  - combat support, 9-36 through 9-38
  - concept, strongpoint defense, 6-53
  - defensive operations, planning, 6-8
  - defensive operations, preparation, 6-15
  - delay, considerations, 6-22
  - delay, scheme, 6-22
  - forms, offensive, 5-7 through 5-20
  - heavy/light forces integration, A-5
  - movement to contact, execution, 5-33
  - movement to contact, planning, 5-27
  - screen, 4-18; 12-4
  - stability operations, 8-16
  - support operations, 8-37
  - withdrawal, scheme, 6-34
- MDMP (see military decision-making process)
- media considerations, 8-12; 8-40
- medical
  - defensive operations, CSS, 10-34
  - field medical assistant, 2-12
  - medical platoon, 2-12, 2-13 (illus)
  - offensive operations, CSS, 10-30
  - surgeon responsibilities, 2-12
- METT-TC (see mission, enemy, terrain and weather, troops and support available, time available, civil considerations)
- military decision-making process (MDMP), 3-11 through 3-22

- executing operations, 3-31 (illus)
- risk management correlation, D-2 (table)
- steps, 3-20 (illus)
- mission, enemy, terrain and weather, troops and support available, time available, civil considerations (METT-TC)
- environmental risk, basis for, E-2 (table)
- heavy/light forces integration, use in, A-1
- sniper employment, as basis, F-2
- urban operations, 7-3 through 7-16
  - civil considerations, 7-15
  - enemy, 7-4 through 7-7; 7-5 (illus)
  - mission, 7-4
  - terrain, 7-7 through 7-13; 7-8 through 7-11 (illus); 7-12 (table)
  - time, 7-15
  - troops, 7-14
- mortars
  - combat support, 9-24 through 9-28; 9-25 (illus); 9-26 (illus)
  - movement to contact, support, 5-24
  - urban operations, support, 7-21
- NBC (see nuclear, biological, chemical)
- nuclear, biological, chemical (NBC), C-1 through C-5
  - attack, 5-37; 5-46
  - characteristics of agents, C-2 (table)
  - contamination avoidance, C-3
  - decontamination, C-5
  - defensive operations, 6-11
  - delay, support, 6-28
  - heavy/light forces integration, A-6
  - MOPP levels, C-4 (table)
  - movement to contact, 5-29
  - nuclear weapons, effects, C-3
  - reconnaissance, C-4
- obstacles
  - actions at, movement to contact, 5-31
  - defensive operations, 6-61 through 6-66
    - effects, 6-63 (table)
    - groups, 6-64
    - plan, 6-61; 6-62 (illus)
    - reserve, 6-64
    - tactical, 6-63
      - planning, 6-65
  - offense, 5-1 through 5-56
    - aviation support, F-3 through F-5
    - contact continuum, 5-2; 5-32 (illus)
    - defend, 1-5
    - focus, 2-4
    - formations, 5-15 through 5-20
    - heavy/light forces integration, A-6 through A-8
    - maneuver, 5-7 through 5-20
    - movement techniques, 5-15
    - organization, 5-3 through 5-7
    - sequence of operations, 5-14
    - snipers, F-3 through F-5
    - transition operations, 5-55
    - types of operations, 5-20 through 5-55
    - urban operations, 7-22 through 7-31; 7-23 (illus); 7-25 through 7-31 (illus)
- operations
  - decisive, 1-8
  - environment, 1-2 through 1-5
  - full spectrum, 1-5
  - main effort, 1-9
  - planning, 3-9 through 3-13
  - process, 3-6; 3-7 (illus)
  - shaping, 1-9
  - sustaining, 1-9
  - operations order (OPORD)
    - ISR, 4-2
      - strongpoint defense, 6-53
    - MDMP, time-constrained, 3-17
    - quick fire planning, CS, fire support, 9-9
  - OPORD (see operations order)

- organization, 2-1 through 2-5
  - armor, 2-3 (illus)
  - capabilities, 2-4
  - limitations, 2-4
  - mechanized infantry, 2-2 (illus)
- passage of lines, 12-10 through 12-15
  - forward, 12-11 (illus); 12-14
  - planning, 12-11
  - rearward, 12-11 (illus); 12-15
  - rehearsal, 12-15
  - support, by BOS, 12-13 through 12-14 (illus)
- penetration
  - enemy, defensive operations, 6-16
  - maneuver, offensive, 5-9; 5-10 (illus)
- perimeter defense, 6-56 through 6-58; 6-57 (illus)
- Posse Comitatus Act, 8-31
- pursuit, 5-52
  - aviation support, B-3
- quick fire planning, CS, 9-8 through 9-10
- raid (special-purpose attack), 5-52
- reconnaissance, 4-22 through 4-29
  - aviation support, B-4 through B-6
  - attack, 5-38 through 5-40; 5-47; 5-51
  - defensive operations, 6-13
  - forms of, 4-11
  - integration of assets, 4-26 through 4-29; 4-27 (illus); 4-28 (illus)
  - movement to contact, 5-30
  - NBC, C-4
  - stability operations, 8-14; 8-15 (table)
  - tiers, 4-7; 4-8 (illus)
- rehearsal
  - attack, 5-38
  - defensive operations, 6-12
  - delay, 6-30
  - fire support, CS, 9-15 through 9-17
  - movement to contact, 5-30
  - passage of lines, 12-16
- reserve
  - defensive operations, planning, 6-40
    - positioning, 6-8
  - offensive operations, 5-6
  - perimeter defense, 6-57 (illus)
  - strongpoint defense, 6-54
- retrograde
  - aviation support, B-6
  - defensive operations, 6-19
  - heavy/light forces integration, A-9
  - maneuver, movement to contact, 5-33; 5-34 (illus)
  - snipers, F-7
- risk management, D-1 through D-6
  - MDMP correlated, D-2 (table)
  - potential hazards, D-3 (table)
  - risk levels, D-4 (table)
- river crossings, 12-21 through 12-24
  - snipers, F-9
- ROE (see rules of engagement)
- ROI (see rules of interaction)
- rules of engagement (ROE)
  - stability operations, 8-9
  - support operations, 8-32
  - urban operations, 7-3
    - modification, 7-35
- rules of interaction (ROI), stability operations, 8-10
- SCATMINES (see scatterable mines)
- scatterable mines (SCATMINES), 9-43 through 9-46
- screen, 4-17; 12-3; 12-4
  - aviation support, B-5
- searches, stability operations, 8-23 through 8-28
- security
  - assembly area operations, 12-46
  - assistance, stability operations, 8-6
  - defensive operations, CSS, 10-34
  - defensive operations, planning, 6-7
  - establish, 6-41
  - offensive operations, CSS, 10-31
  - support operations, 8-42
- security area, defensive operations, 6-1
  - actions in preparation, 6-13

- delay, 6-30
- engagement, 6-42
- security operations, 4-17 through 4-22
  - area, 4-22; 12-8
  - aviation support, B-5
  - cover, 4-22; 12-8
  - defensive operations, 6-42
  - guard (see separate entry), 4-18; 4-19 (illus)
  - screen (see separate entry), 4-18; 4-19 (illus); 12-5
  - tactical enabling operations, 12-3 through 12-9
- sniper employment, F-1 through F-10
- SOSRA (see suppress, obscure, secure, reduce, assault)
- spoiling attack (special-purpose attack), 5-54
- stability operations, 8-1 through 8-30
  - considerations, by BOS (see separate entries), 8-13 through 8-20
  - focus, 2-5
  - force protection, 8-11
  - full spectrum operations, 1-5
  - media considerations, 8-12
  - sniper, F-9
  - techniques, 8-20 through 8-30
  - types, 8-3
- Stinger missile, 9-53
- strongpoint defense, 6-51 through 6-56; 6-52(illus); 6-55 (illus)
- support operations, 8-30 through 8-46
  - focus, 2-5
  - full spectrum operations, 1-5
  - sniper, use in, F-9
- suppress, obscure, secure, reduce, assault (SOSRA), see breach fundamentals
- sustain, CSS operation, 10-18 through 10-24; 10-19 (illus); 10-20 (illus); 10-21 (illus)
- tactical enabling operations (see separate entries), 12-1 through 12-47
  - assembly area operations, 12-40 through 12-47
  - battle handover, 12-9
  - combined arms breaching, 12-24 through 12-34
  - linkup, 12-16 through 12-20
  - passage of lines, 12-10 through 12-15
  - relief operations, 12-1 through 12-3
  - river crossing, 12-21 through 12-24
  - security operations, 12-3 through 12-9
  - tactical road march, 12-34 through 12-40
- terrain
  - analysis, ISR, defensive operations, 6-39
  - effects, delay, 6-22
  - management, reconnaissance, 4-16
  - maximizing advantages, attack, 5-44; 5-45 (illus)
  - urban mapping, 7-7 through 7-11; 7-8 through 7-11 (illus)
  - urban operations, analysis, METT-TC, 7-6; 7-11 through 7-13; 7-12 (table)
- urban operations, 7-1 through 7-37
  - aviation support, B-19 through B-25
  - snipers, F-8
- warning order (WARNO)
  - ISR, 4-2; 4-5
  - MDMP, 3-14; 3-15; 3-16; 3-19
- WARNO (see warning order)
- weapons control status, 9-52 (illus)
- weather
  - analysis, urban operations, METT-TC, 7-13
  - close air support, CS, 9-36
- withdrawal, 6-32 through 6-37
  - aviation support, B-6
- XO (see executive officer)

By Order of the Secretary of the Army:

Official:



JOEL B. HUDSON  
*Administrative Assistant to the  
Secretary of the Army*

0315703

ERIC K. SHINSEKI  
*General, United States Army  
Chief of Staff*

**DISTRIBUTION:**

*Active Army, Army National Guard, and U. S. Army Reserve:* To be distributed in accordance with the initial distribution number 110506, requirements for FM 3-90.2.



**PIN: 080859-000**